

A-A

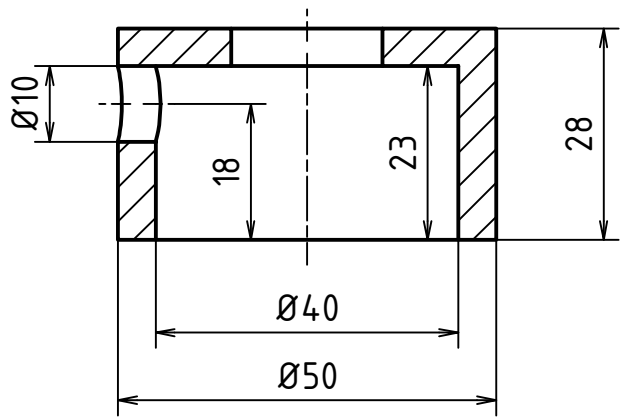

NAVŘHL	Autor	Datum	SCHVÁLIL	Podpis	Datum	HMOTNOST 0,189 kg	MĚŘITKO
MICHAL		17.06.2021				PROMÍTÁNÍ: $\begin{matrix} \triangleleft \\ \oplus \end{matrix}$ (ISO E)	1:1

 ČESKÉ VYSOKÉ UČENÍ TECHNICKÉ V PRAZE	FAKULTA STROJNÍ	NÁZEV	Přívod
		ČÍSLO VÝKRESU	Injector assembly