

Humility to Dom square/
Pokoru Dómskému náměstí
Litoměřice
ZS 2019/2020

Atelier Rehwaldt - Concepcion
Franziska-R. Soukupová

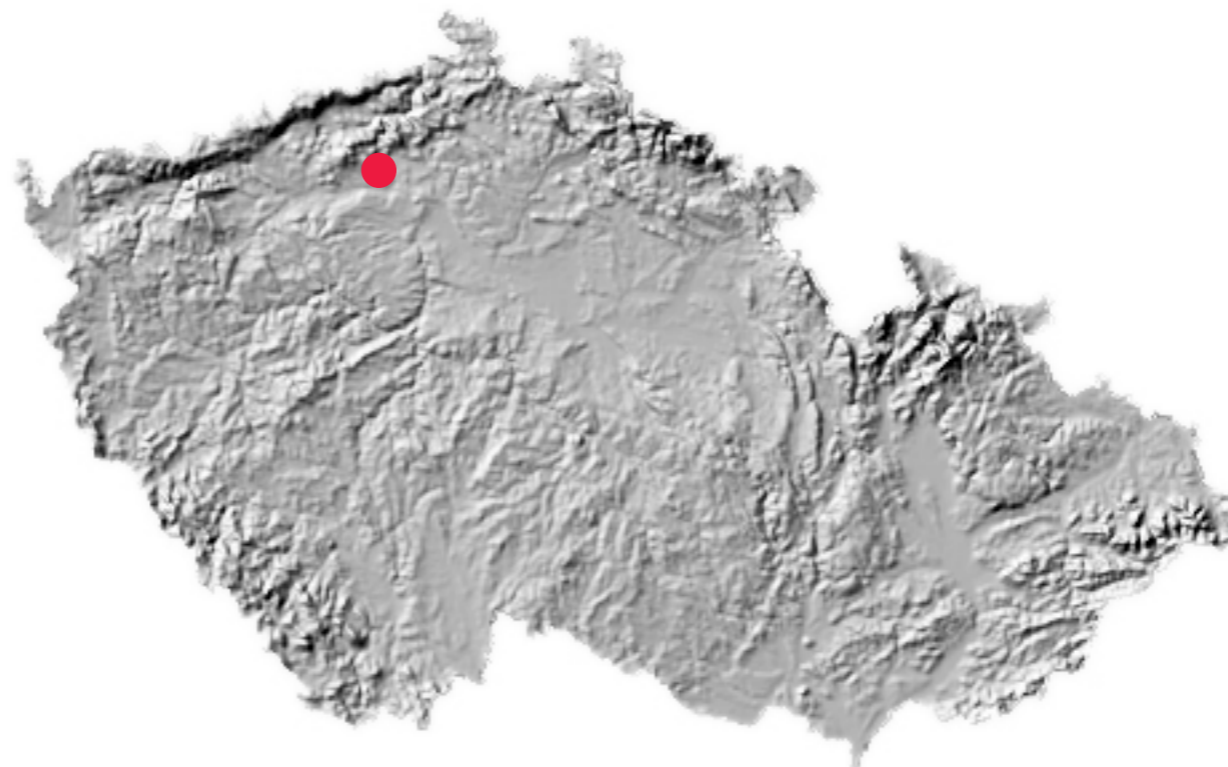

NATURAL CONDITOOON ANALYSIS / ANALÝZA PŘÍRODNÍCH PODMÍNEK
A)GEOMORPHOLOGIE/GEOMORFOLOGIE

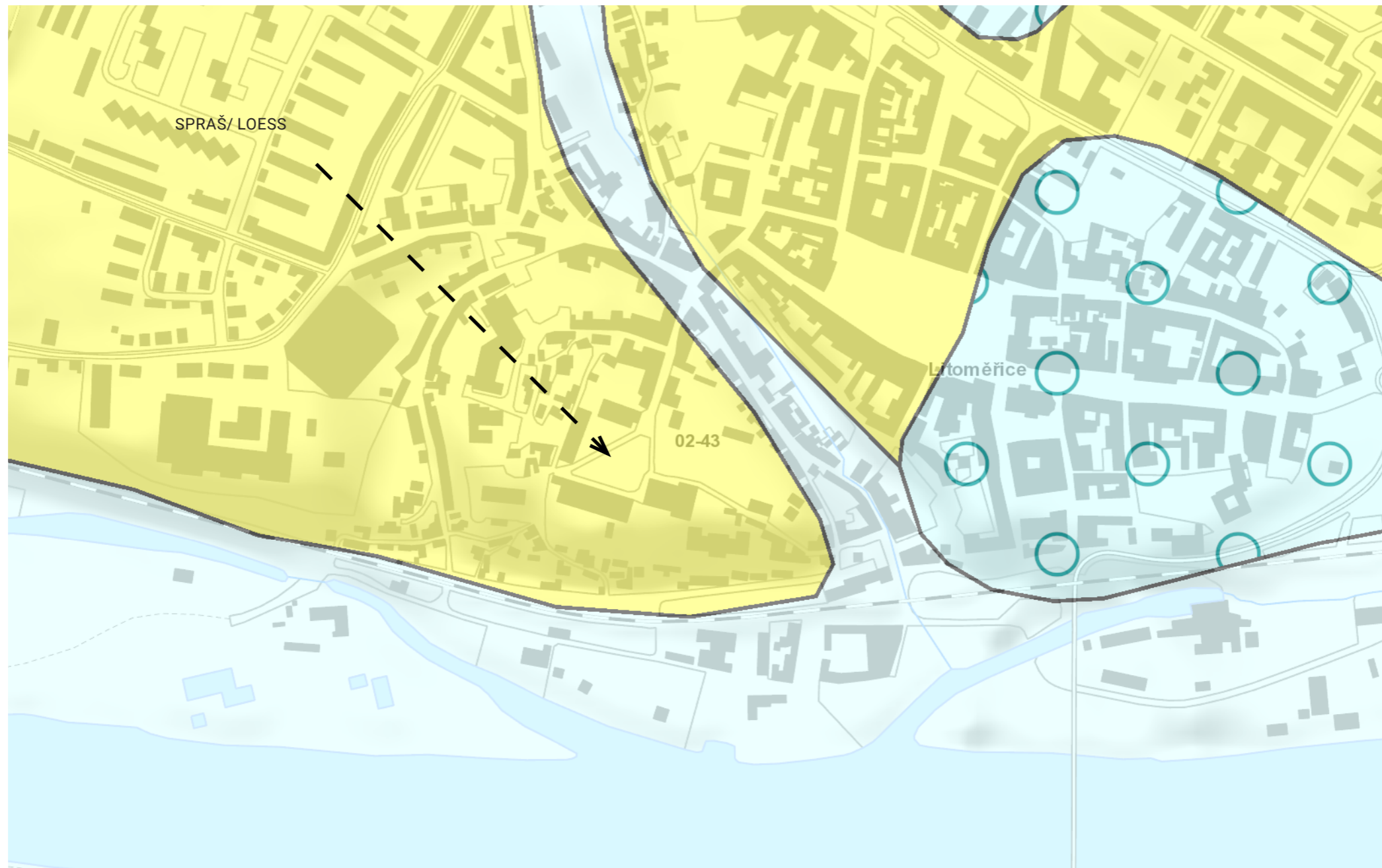

L Lesy

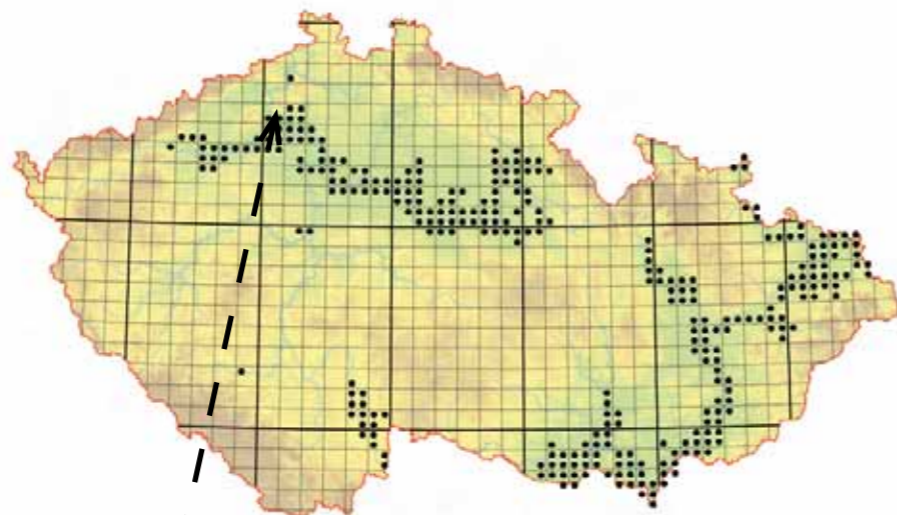

Rozšíření tvrdých luhů nížinných řek. Celková rozloha biotopu v České republice je přibližně 23 700 ha.

HARDWOOD FOREST OF LOWLAND RIVERS/TVRDÉ LUHY NÍŽINNÝCH ŘEK

TYPICKÉ DŘEVINY: QUERCUS ROBUR, ULMUS LAEVIS
A U. MINOR, ACER CAMPESTRE, PRUNUS PADUS SUBSP.
ADUS A TILIA CORDATA,

T Sekundární trávníky a vřesoviště

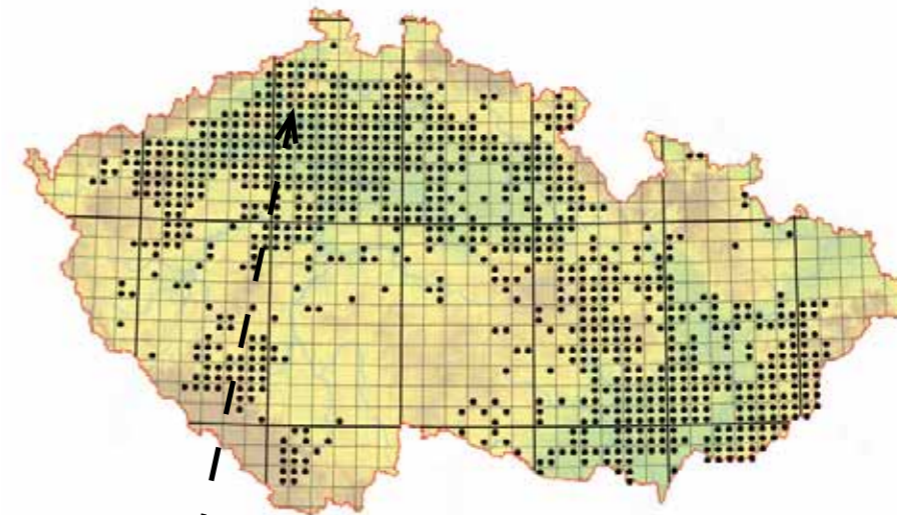

Rozšíření širokolistých suchých trávníků. Celková rozloha biotopu v České republice je přibližně 12 000 ha.

BROAD-LEAVED DRY GRASSLAND/ŠIROKOLISTÉ SUCHÉ TRÁVNÍKY

TYPICKÉ SLOŽENÍ: BRACHYPODIUM PINNATUM, BROMUS
ERECTUS, FESTUCA RUPICOLA, SESLERIA CAERULEA

NATURAL CONDITIOON ANALYSIS / ANALÝZA PŘÍRODNÍCH PODMÍNEK
C)CLIMATE/KLIMATICKÉ ÚDAJE

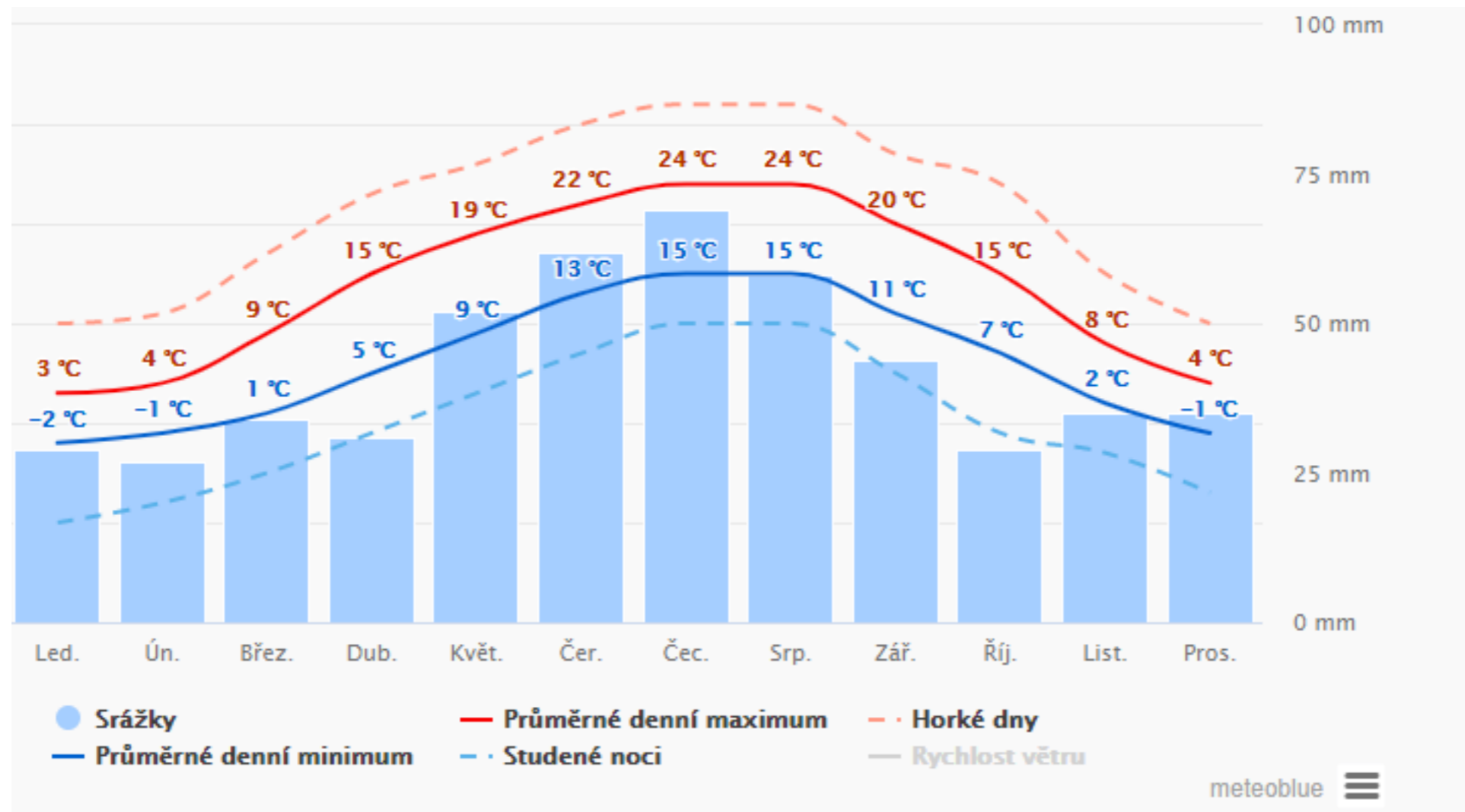

ANNUAL RAINFALL/ROČNÍ ÚHRN SRÁŽEK: 550 MM
ANNUAL TEMPERATURE/PRŮMĚRNÁ ROČNÍ TEPLOTA: 10 CELSIUS
USUAL WIND DIRECTION: SW/NE - JZ/SV

NATURAL CONDITIOON ANALYSIS / ANALÝZA PŘÍRODNÍCH PODMÍNEK
D) PEDOLOGIE

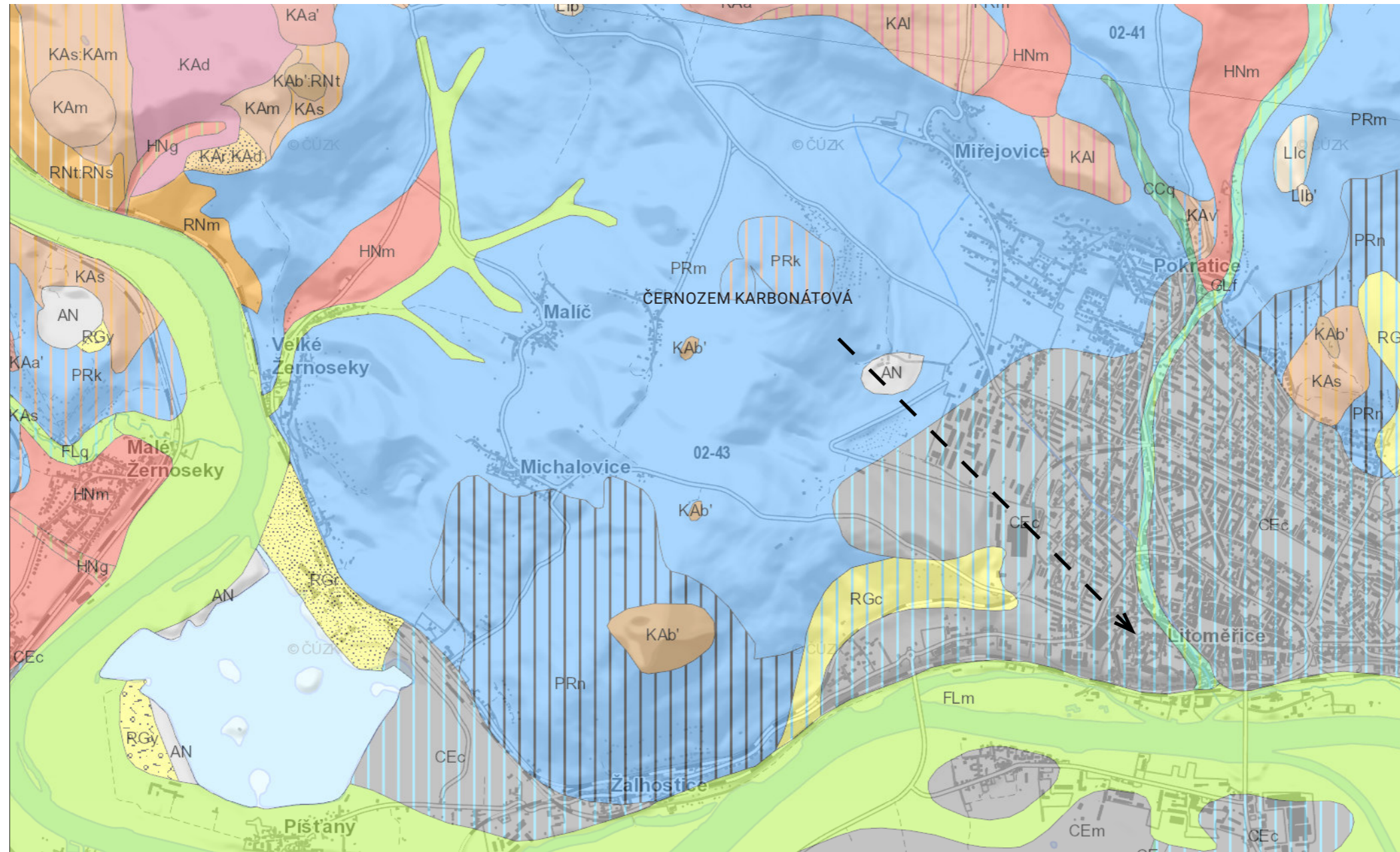

DŮLEŽITÉ VÝHLEDY
1 - ORTODOXNÍ KOSTEL SV. VÁCLAVA
2 - KAMENNÁ VĚŽ PŘI KOSTELU
VŠECH SVATÝCH A RADNICE
3 - KATEDRÁLA SV. ŠTĚPÁNA

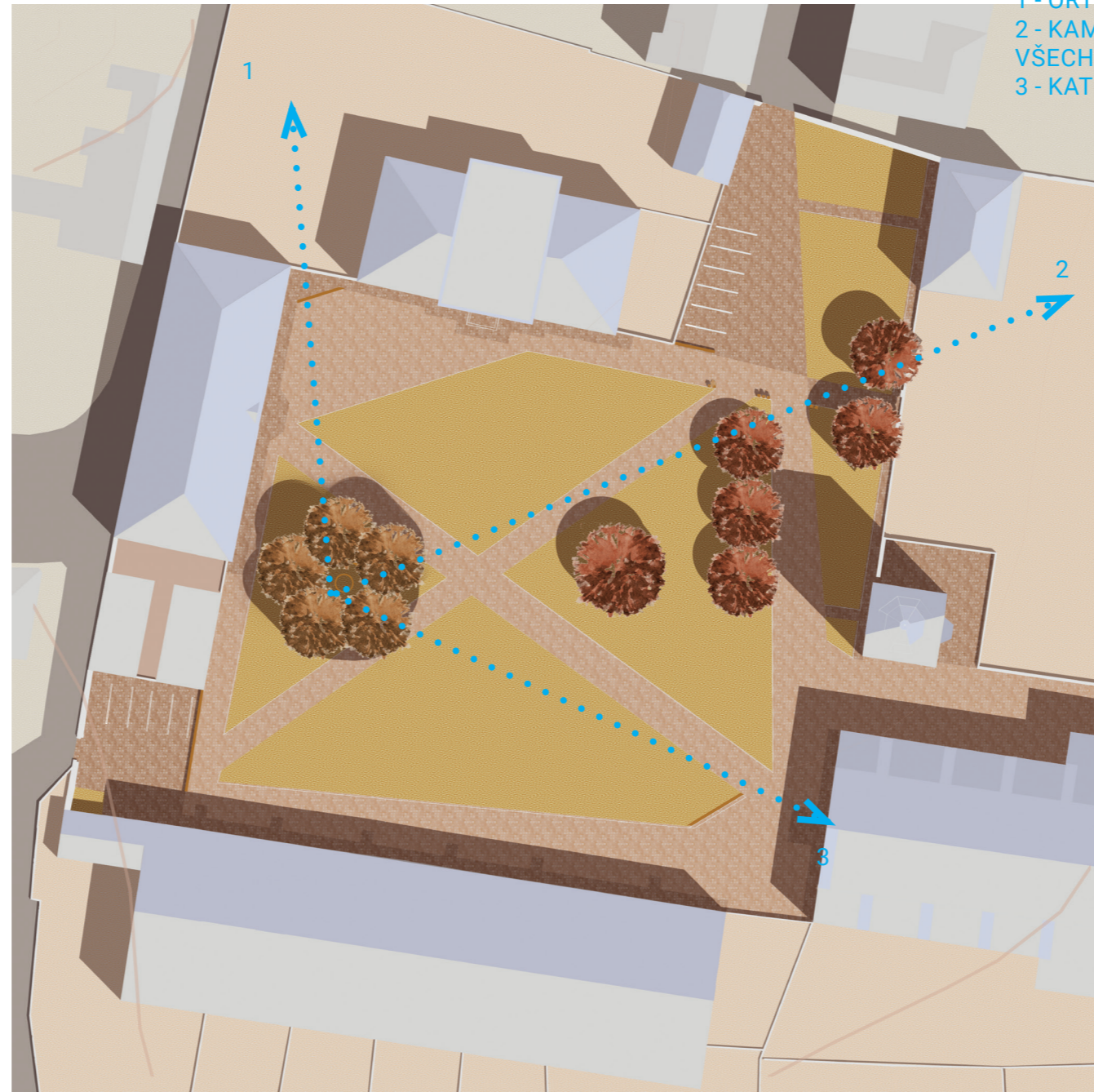

URBAN CONDITIOON ANALYSIS / ANALÝZA URBÁNNÍCH PODMÍNEK
E) LIMITS/LIMITY

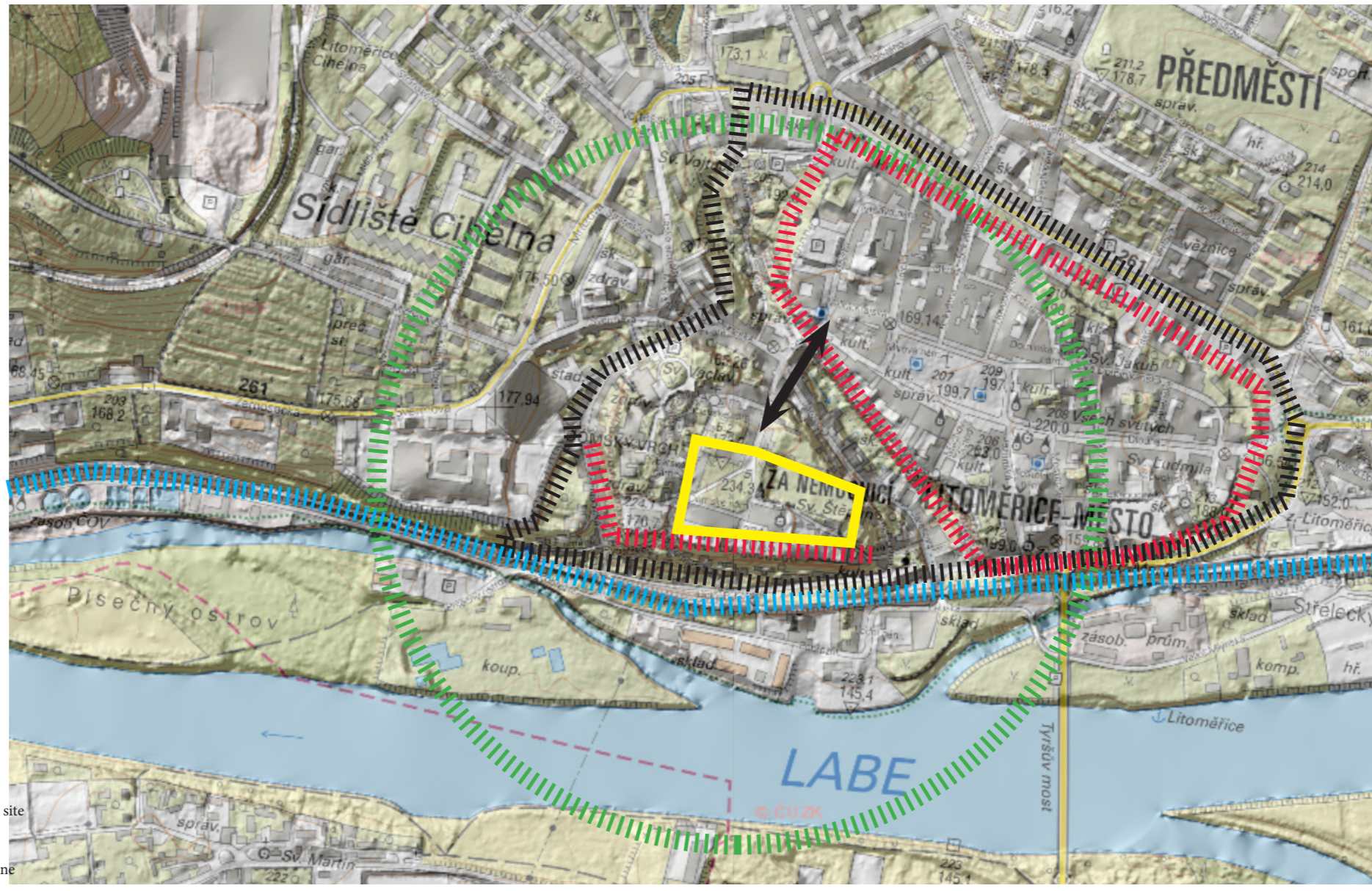

- heritage site
- walls
- flood zone
- area of interest
- main connection between dom and city hill

URBAN CONDITON ANALYSIS / ANALÝZA URBÁNNÍCH PODMÍNEK
F) TRAFFIC/DOPRAVA



zdroj podkladní mapy: <http://litomerice-leitmeritz.net/>

URBAN CONDITON ANALYSIS / ANALÝZA URBÁNNÍCH PODMÍNEK
G) PUBLIC SPACES/ VEŘEJNÁ PROSTRANSTVÍ







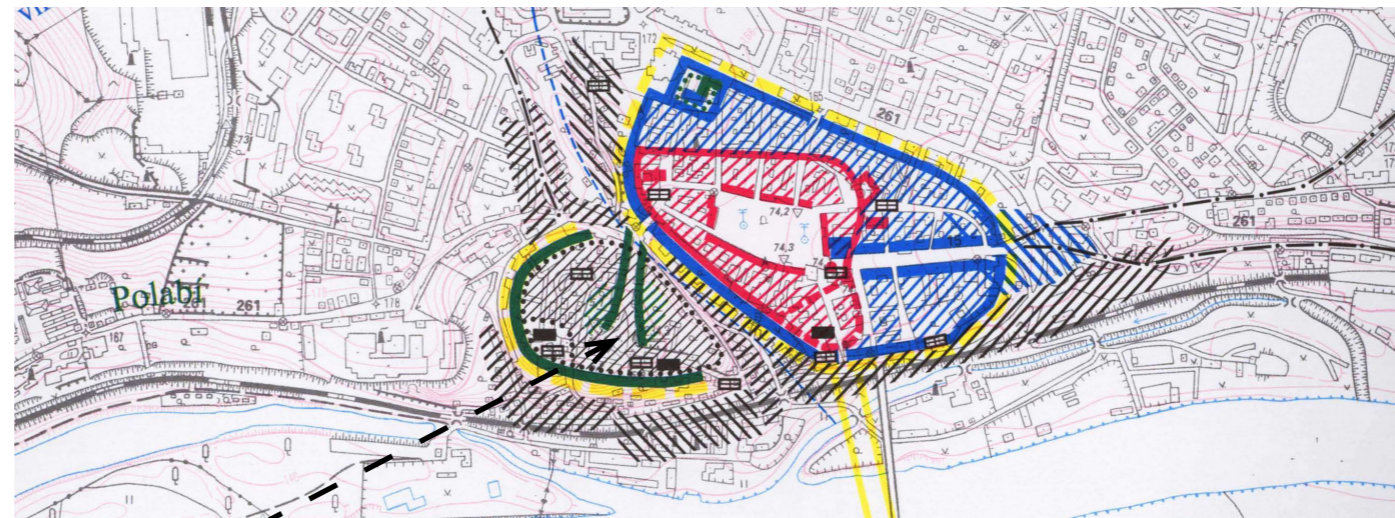













URBAN CONDITON ANALYSIS / ANALÝZA URBÁNNÍCH PODMÍNEK
H) HISTORIC EVOLUTION

PRIMARY URBAN STRUCTURES WITH HILLFORT FROM 10TH CENTURY



1057 FOUNDING A
CHAPTER BY PRINCE
SPITIHŇEV II. WITH
PROBOSTERY AND
BASILIC OF ST.
STEPHAN

	hradiště a jeho obvod		předměstí (vesměs předkolonizačního původu)		významné objekty (kapitula, kláštery, hrad, palác, radnice)
	prvotní rozsah právního města (villa, civitas, čtvrť 13. – polovina 14. stol.)		předměstí náležející litoměřické kapitule		most (od r. 1452)
	městská věž u kostela Všech svatých		předměstská osada Újezd kapituly vysehradské, darovaná městu r. 1351 Karlem IV.		vnější pás opevnění (počátek 16. stol.)
	uvnitř města: náměstí, tržní prostor		rozšíření města za Karla IV. (cca r. 1351–1359)		bahniště Polabí (pozemky darované městu r. 1319 Janem Lucemburským)
	pokus rozšířit město do oblasti starého hradiště (1257–1262)		uvnitř města: tržní prostor Dlouhé ulice		cesty
	částečné nové hradby				Pokratický potok
	královský hrad (možná doba vzniku 2. pol. 13. – zač. 14. stol.), válcová věž hradu				

Polabí
vinice

URBAN CONDITON ANALYSIS / ANALÝZA URBÁNNÍCH PODMÍNEK
I) HISTORIC EVOLUTION

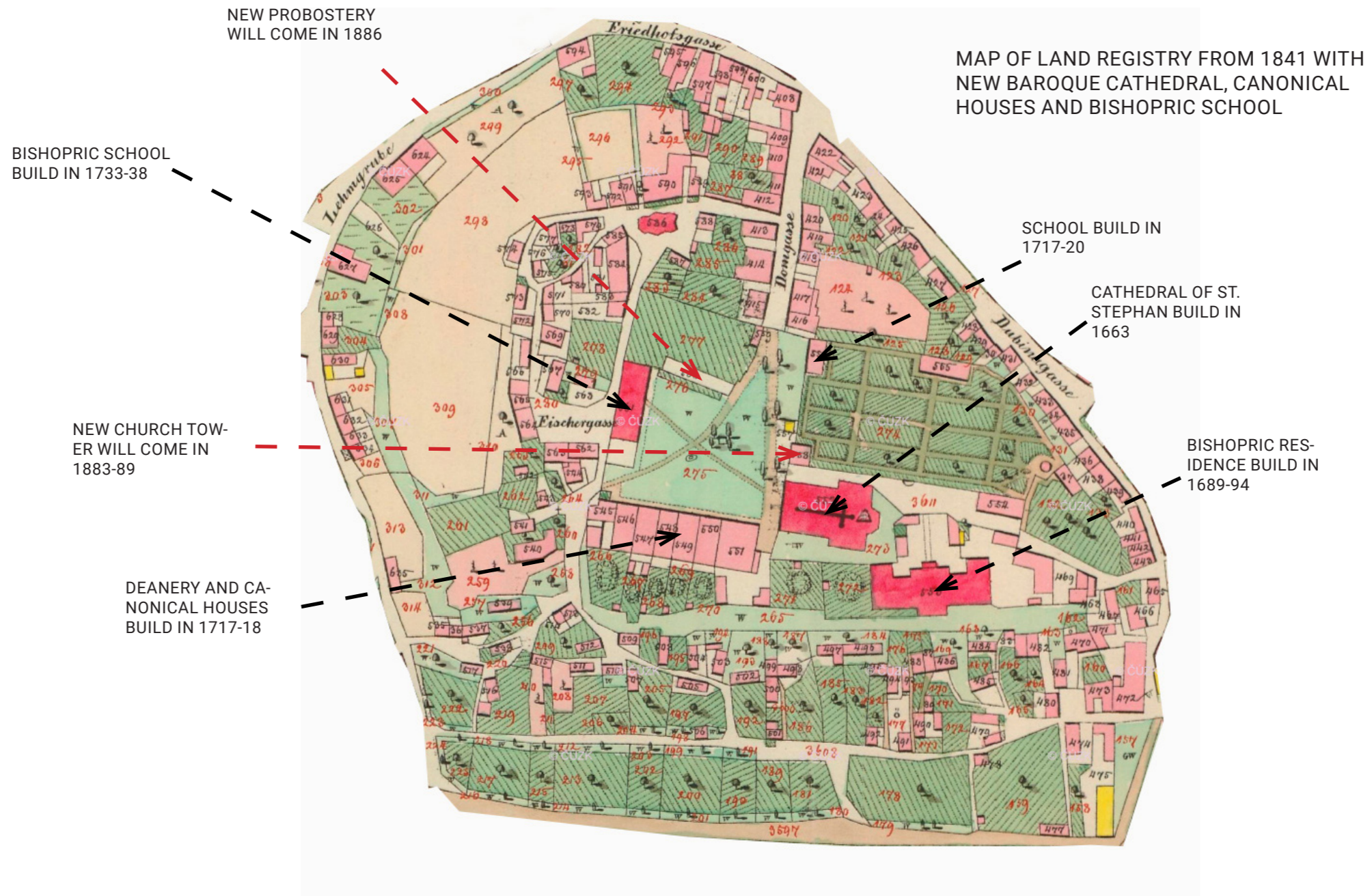

URBAN CONDITON ANALYSIS / ANALÝZA URBÁNNÍCH PODMÍNEK
I) HISTORIC EVOLUTION



CURRENT CONDITIONS
SOUČASNÁ SITUACE



DIVIDING THE SPACE INTO MAIN SQUARE
AND FOYERS

ROZDĚLENÍ PROSTORU NA HLAVNÍ VEŘEJNÝ
PROSTOR A PŘIDRUŽENÍ PŘEDPROSTORY

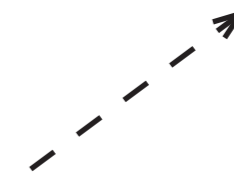

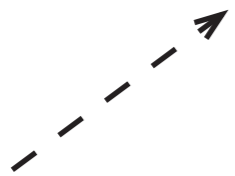

MAIN AXIS AND ACCESES TO THE AREA
HLAVNÍ OSY A PŘÍSTUPY DO AREÁLU



PRIMARY DESIGN
PRVOTNÍ NÁVRH

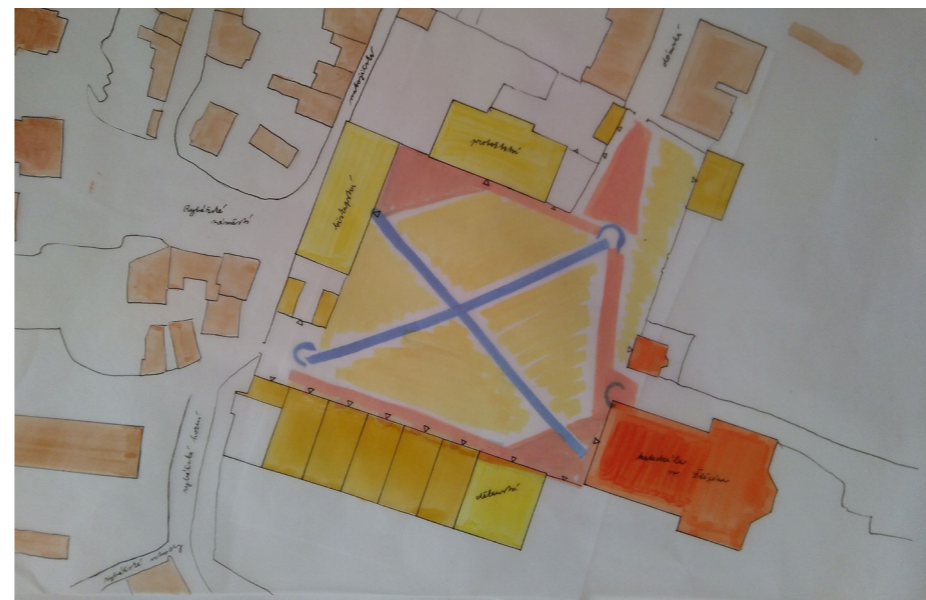

DIVIDING THE SPACE IN THE FINAL DESIGN
BY USAGE OF DIFERENT COLORS OF PAVE-
MENT AND ENTRANCE WALLS

ODDĚLENÍ PROSTORU OD HLAVNÍHO POSTAVÁNÉHO ZA POMOCI UŽITÍ
TMAVÉHO BAZALTU, KTERÝ SE V SOUČASNÉ DOBĚ V AREÁLU ROZPTÝLENĚ
VYSKYTUJE A ZA POMOCI DODATEČNÝCH VSTUPNÍCH BRAN

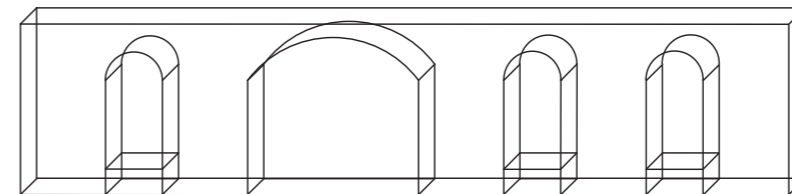
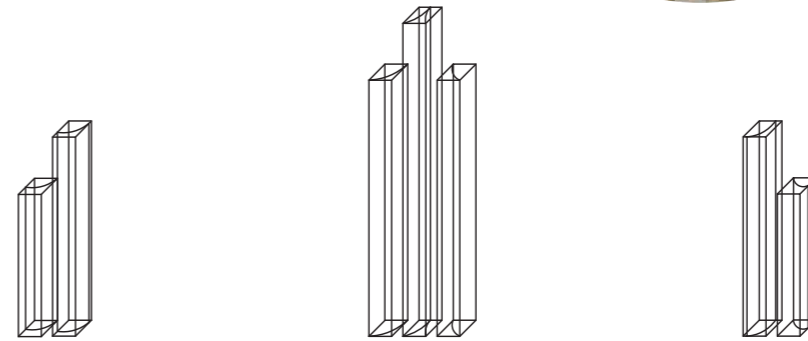
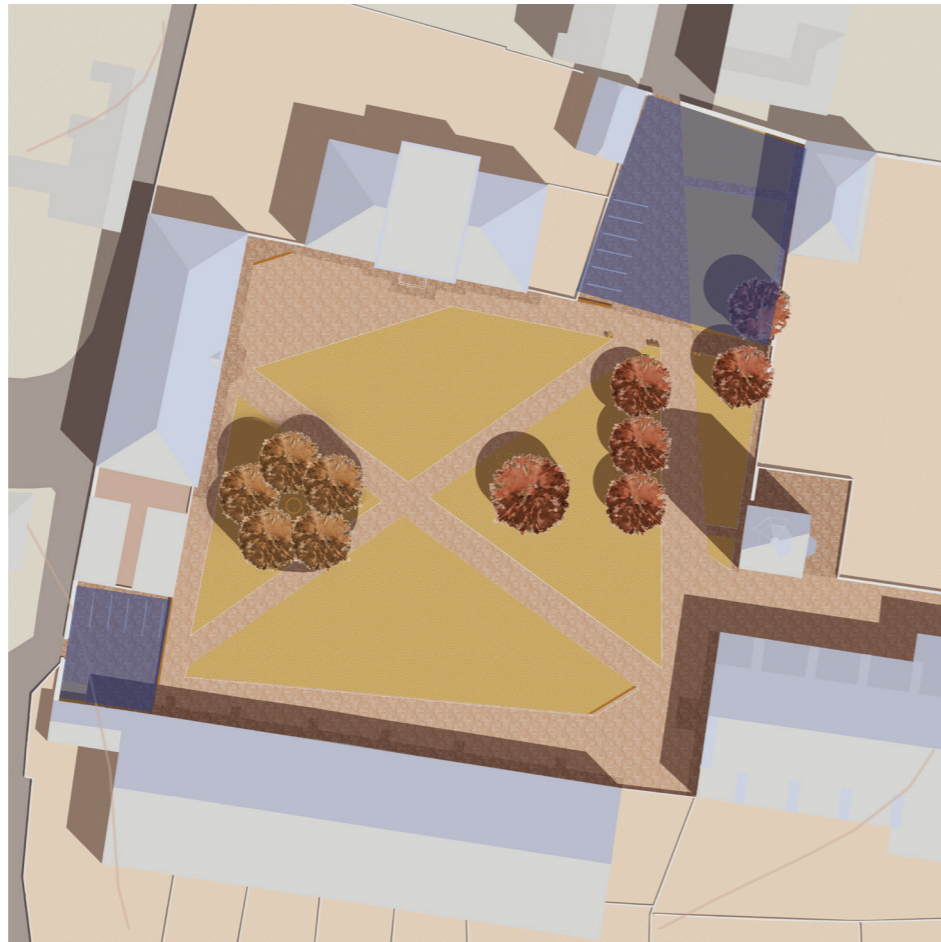

NORTH FOYER

THE MAIN ENTRANCE FROM CITY CENTER WITH BAROQUE GATE FROM 1662

AS IN MANY OLD TOWNS PARKING IN HISTORICAL CENTER IS A PAINFUL ISSUE, NOWADAYS IS DOM SQUARE MAINLY USED AS AN ADDITIONAL URBAN PARKING LOT.

TO CALM THE SPACE I HAVE CREATED A SECONDARY CLOSURE.

I HAVE RAISED 7 COLOMS AS A REMINESCERY AT CATHEDRAL ORGANS, THEY WITH THE NEW BEECH WALL ARE DIVIDING THE NORTH FOYER FROM THE MAIN SQUARE.

FOYER IS THE SPACE, WHERE YOU ARE PREPARING YOURSELF FOR ENTRANCING THE CALM SACRED AREA, LAST AREA TO BE EARTHLY. LAST SPACE WHERE YOU CAN LEAVE YOUR TERRITORIAL STATES, YOUR CARS.

IT IS PAVED WITH THE DARKER BAZALT, AS THE ACT "THIS IS THE SPACE, WHERE YOU LEAVE YOUR DIRT BEHIND."



WEST FOYER

THE ENTRANCE FROM THE RESIDENTIAL DISTRICT RY-BÁŘE WITH ROKOQUE GATE

THIS GATE IS ON THE OLD ROUTE BETWEEN THE CHURCH AREA AND OLD CASTLE.

TO BRING UP THE MEANING OF THIS GATE, I HAVE WORKED WITH THE CARDINAL DIRECTIONS - EAST-WEST, WHERE THE ROUTE BETWEEN CATHEDRAL AND THE GATE IS PLACED.

I HAVE SEPERATED THE TINY FOYER FROM THE MAIN SQUARE BY BUILDING SECOND GATE IN A WALL MADE FROM RESIN.

THROUGH THE RESIN LIGHTED UP THE SUNRISE ABOVE THE CATEDRAL IN THE MORNING AND THE SUNSET ABOVE THE EXIT IN THE EVENING.







DLAŽBA Z BAZALTU

TILIA
CORDATA

SUCHÁ KVĚTNATÁ
LOUKA SMĚS SLUN-
OVRAT (AGROSTIS)

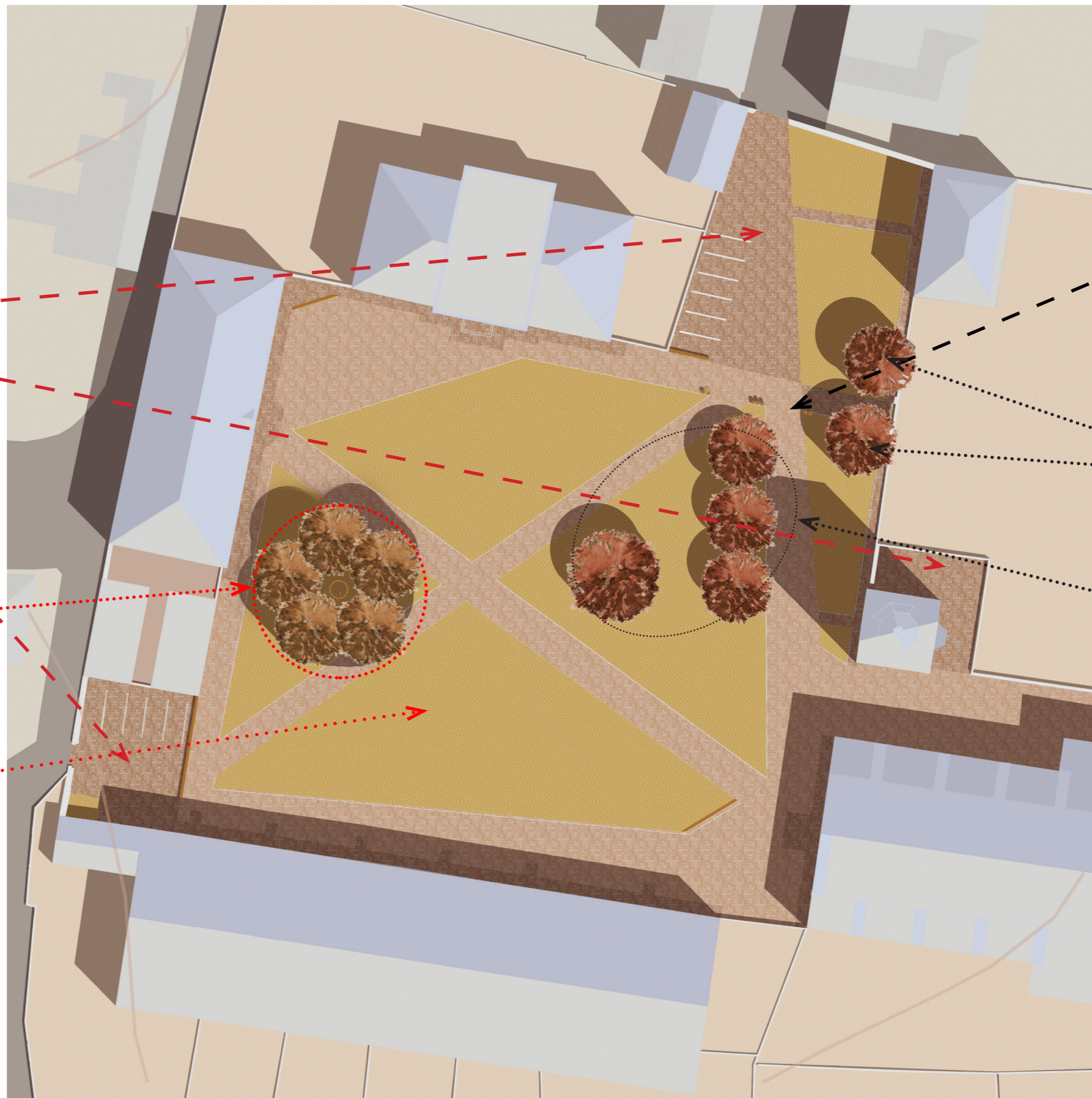

ŽULOVÁ DLAŽBA

AESCULUS
HIPPOCASTA-
NUM

TILIA CORDATA

