

Bachelor Project



**Czech
Technical
University
in Prague**

F3

**Faculty of Electrical Engineering
Department of Control Engineering**

ABS system modelling and control strategies development

Tomáš Veselý

**Supervisor: Ing. Tomáš Haniš, PhD.
Field of study: Cybernetics and Robotics
May 2020**

I. Personal and study details

Student's name: **Veselý Tomáš** Personal ID number: **474780**
Faculty / Institute: **Faculty of Electrical Engineering**
Department / Institute: **Department of Control Engineering**
Study program: **Cybernetics and Robotics**

II. Bachelor's thesis details

Bachelor's thesis title in English:

ABS system modelling and control strategies development

Bachelor's thesis title in Czech:

Modelování a návrh řízení systému ABS

Guidelines:

The goal of thesis is development of braking system control strategies, providing particular wheel anti-blocking functionality. The thesis will augment nowadays Anti-locking Brake Systems. The thesis will address following points:

1. Review of current ABS systems
2. Implementation of single-track model with braking components augmentation
3. Development of braking system control strategies
4. Validation of developed algorithms

Bibliography / sources:

- [1] Dieter Schramm, Manfred Hiller, Roberto Bardini – Vehicle Dynamics – Duisburg 2014
- [2] Hans B. Pacejka - Tire and Vehicle Dynamics – The Netherlands 2012
- [3] Franklin, Powell, Emami-Naeini: Feedback Control of Dynamics Systems. Prentice Hall, USA
- [4] Robert Bosch GmbH - Bosch automotive handbook - Plochingen, Germany : Robert Bosch GmbH ; Cambridge, Mass. : Bentley Publishers

Name and workplace of bachelor's thesis supervisor:

Ing. Tomáš Haniš, Ph.D., Department of Control Engineering, FEE

Name and workplace of second bachelor's thesis supervisor or consultant:

Date of bachelor's thesis assignment: **07.02.2020** Deadline for bachelor thesis submission: **22.05.2020**

Assignment valid until: **30.09.2021**

Ing. Tomáš Haniš, Ph.D.
Supervisor's signature

prof. Ing. Michael Šebek, DrSc.
Head of department's signature

prof. Mgr. Petr Páta, Ph.D.
Dean's signature

III. Assignment receipt

The student acknowledges that the bachelor's thesis is an individual work. The student must produce his thesis without the assistance of others, with the exception of provided consultations. Within the bachelor's thesis, the author must state the names of consultants and include a list of references.

Date of assignment receipt

Student's signature

Acknowledgements

I would like to express my gratitude to my supervisor Ing. Tomáš Haniš, PhD. for his friendly attitude, excellent advice and for his time.

Also, I would like to thank to Ing. Vít Cibulka, for selflessly providing his twin-track model.

Declaration

I hereby declare that this bachelor thesis was developed independently and that I have cited all used sources of information in accordance with the methodical instructions for observing the ethical principles in the preparation of a university thesis.

In Prague, May 22, 2020

.....

Abstract

The goal of this thesis is to augment the twin-track vehicle model with the brake system components and to develop brake system control algorithms. The thesis compares the-state-of-the art hydraulic brake systems with recently proposed concepts like the regenerative brake systems, brake-by-wire systems and brake-by-steer systems.

The main goal of this thesis is to design algorithms for an independent brake torque control of each wheel, which will ensure maximal brake performance, steerability and stability of the vehicle for various road conditions. The designed brake torque control algorithms are based on an innovative feedback control.

Finally, an emergency brake system based on the Brake by steer concept is designed, which can increase the safety of the Brake by wire concept.

Keywords: Twin-track vehicle model, brake system components, independent brake torque control, hydraulic brakes, regenerative brake systems, Brake by wire, Brake by steer, ABS system

Supervisor: Ing. Tomáš Haniš, PhD.
Czech Technical University in Prague
Faculty of Electrical Engineering
Department of Control Engineering -
K13135
Karlovo náměstí 13
12135 Praha 2

Abstrakt

Cílem této práce je rozšířit model dvoustopého vozidla o komponenty brzdné soustavy a navrhnout algoritmy řízení brždění kol. Práce srovnává dnes běžně používaný koncept, kterým jsou hydraulické brzdy, s nově vznikajícími koncepty jako jsou rekuperace, Brake by wire nebo Brake by steer.

Hlavním cílem práce je navrhnout algoritmy pro nezávislé řízení brzdného momentu na každém kole, které zajistí maximální brzdný výkon, říditelnost a stabilitu vozidla pro různé povrchy. Navržené algoritmy řídicí brždění kol jsou založeny na inovativním zpětnovazebném řízení.

Nakonec je navržen nouzový brzdný systém založený na konceptu Brake by steer, jenž může zvýšit bezpečnost konceptu Brake by wire.

Klíčová slova: Dvoustopý model vozidla, komponenty brzdné soustavy, nezávislé řízení brždění kol, hydraulické brzdy, rekuperace, Brake by wire, Brake by steer, ABS systém

Překlad názvu: Modelování a návrh řízení systému ABS

Contents

1 Introduction	1		
1.1 Goals	1		
2 Vehicle model	3		
2.1 Vehicle body	6		
2.2 Chassis	6		
2.2.1 Tire model	6		
2.3 Powertrain	8		
3 Brake systems overview	9		
3.1 Hydraulic brake system	9		
3.1.1 Mechanical hydraulic brake systems	10		
3.1.2 Electro hydraulic brake systems	13		
3.2 Regenerative brake system	15		
3.3 Brake-by-wire	15		
3.3.1 Electro mechanical brake system	16		
3.4 Brake-by-steer	17		
4 Implementation of the brake subsystems	19		
4.1 Hydraulic brake system	19		
4.2 In-wheel electric motor for regenerative brake system	21		
4.3 Mechatronic brake actuator for brake-by-wire	22		
5 Anti-lock brake systems	25		
5.1 Anti-lock brake system overview	25		
6 ABS systems design	27		
6.1 Proposed control approaches	27		
6.1.1 Conventional ABS approach	27		
6.1.2 Drive-by-wire approach	29		
6.1.3 Comparison of conventional ABS and drive-by-wire approach	30		
6.2 Standalone ABS system	31		
6.2.1 Hydraulic ABS system	31		
6.2.2 Brake-by-wire ABS system	33		
6.2.3 Regenerative ABS system with brake-by-wire	34		
6.2.4 Validation	35		
6.3 Regenerative ABS system based on Simscape models	38		
6.3.1 Validation	39		
7 Brake-by-steer system design	43		
7.1 System design	43		
7.2 Validation	45		
7.2.1 Test 1 - Reference tracking	45		
7.2.2 Test 2 - Emergency braking	46		
7.2.3 Test 3 - μ -split condition	49		
8 Conclusion & future work	53		
8.1 Future work	54		
A Bibliography	55		
B Figures	57		
C Parameters of used models	75		
D Attachment	77		

Figures

<p>2.1 Scheme of modified twin-track model. 4</p> <p>2.2 Earth-fixed and body fixed coordinate system. Adopted from [SHB14] 4</p> <p>2.3 Coordinate system of i^{th} wheel. Adopted from [Cib19]. 5</p> <p>2.4 Top view of the vehicle model. Adopted from [SHB14]. 5</p> <p>2.5 Side view of the vehicle model. Adopted from [SHB14]. 5</p> <p>2.6 Friction ellipse for constant coefficient. Adopted from [Lib16]. 8</p> <p>3.1 Scheme of the hydraulic brake system. Adopted from [vHnk14]. 11</p> <p>3.2 Scheme of the hydraulic brake system with hydraulic control unit. Adopted from [vHnk14]. 12</p> <p>3.3 Scheme of the electro hydraulic brake system. Adopted from [Gmb14]. 14</p> <p>3.4 Scheme of the brake-by-wire actuator. Adopted from [MK14]. 16</p> <p>3.5 Brake-by-steer concept. 18</p> <p>4.1 Scheme of the modified fixed caliper disc brake subsystem. 20</p> <p>4.2 Step response of hydraulic system for step time 0.1 s. 20</p> <p>4.3 Comparison of Simscape model (SM) and identified system transfer function (TF) step response for step time 0.1 s. 21</p> <p>4.4 Scheme of the implemented motor system. 22</p>	<p>4.5 Step response of in-wheel motor system for step time 0.01 s and step input 500 Nm. 22</p> <p>4.6 Block scheme of the electronic brake actuator. 23</p> <p>4.7 Step response of the electronic actuator and the identified system for step time 0.01 s. 23</p> <p>6.1 Block scheme of the conventional ABS system. 28</p> <p>6.2 Friction coefficient curves for different surfaces. Adopted from [BBS11]. Note that the twin-track model defines negative slip ratios for braking. 28</p> <p>6.3 Simulink block scheme of the used hydraulic brake system. 29</p> <p>6.4 Block scheme of the drive-by-wire system. 30</p> <p>6.5 Comparison of reference input signal tracking. 30</p> <p>6.6 Comparison of stopping distance for fully braking under adverse road conditions. 31</p> <p>6.7 Block scheme of the hydraulic ABS. 32</p> <p>6.8 Scheme of the PI regulator with anti-windup filter. 34</p> <p>6.9 Scheme of the braking subsystem for regenerative ABS system. 34</p> <p>6.10 The reference acceleration tracking comparison. 35</p> <p>6.11 The brake torque comparison of the ABS systems. 36</p> <p>6.12 Comparison of vehicle stopping distances for $k = 0.2$. 37</p>
------------------------------------------------------------------------------------------------------------------------------------------------------------------------------------------------------------------------------------------------------------------------------------------------------------------------------------------------------------------------------------------------------------------------------------------------------------------------------------------------------------------------------------------------------------------------------------------------------------------------------------------------------------------------------------------------------------------------------------------------------------------------------------------------------------------------------------------------------------------------------------------------------------------------------------------------------------------------------------------------------------------------------------------------------------------------------------------------------------------------------------------------------------------------------------------------------------------------------------------------------------------------------------------	------------------------------------------------------------------------------------------------------------------------------------------------------------------------------------------------------------------------------------------------------------------------------------------------------------------------------------------------------------------------------------------------------------------------------------------------------------------------------------------------------------------------------------------------------------------------------------------------------------------------------------------------------------------------------------------------------------------------------------------------------------------------------------------------------------------------------------------------------------------------------------------------------------------------------------------------------------------------------------------------------------------------------------------------------------------------------------------------------------------------------------------------------------------------------------------------------------------------------------------------------------------------------------------------------------------------------------

6.13 Comparison of vehicle stopping distances for $k = 0.4$	37	7.7 Generated forces on the wheels for $k = 0.2$. The blue line represents force in x -axis, the red line represents force in y -axis in wheel coordinate system..	48
6.14 Rotation around z -axis induced by μ -split condition.	38	7.8 Vehicle lateral speed and yaw angle.	48
6.15 The brake and motor torque comparison.	39	7.9 Vehicle speed.	49
6.16 The reference acceleration tracking.	40	7.10 Generated steering angles in both tests.	49
6.17 The stopping distance of the vehicle for $k = 0.4$	40	7.11 Generated forces on the wheels for $k = 0.2$ on the left side. The blue line represents force in x -axis, the red line represents force in y -axis in wheel coordinate system.	50
6.18 Rotation around z -axis induced by μ -split condition.	41	7.12 Generated forces on the wheels for $k = 0.8$ on the left side. The blue line represents force in x -axis, the red line represents force in y -axis in wheel coordinate system.	50
6.19 The top graph represents detected wheel speed failures. Error meanings: 0 represents no error, 1 represents the motor speed sensor error, 2 represents the wheel speed error, 3 represents error of both sensors.	42	7.13 Vehicle lateral speed and yaw angle.	51
7.1 Block scheme of the designed brake-by-steer system.	43	7.14 Vehicle speed.	51
7.2 Possible steering configurations.	44	B.1 Test scenario no.1 - input reference tracking. The conventional hydraulic ABS system.	58
7.3 Reference signal tracking and vehicle lateral stability.	45	B.2 Test scenario no.1 - input reference tracking. The hydraulic based ABS system with the drive-by-wire approach.	59
7.4 Forces on the wheels induced by steering. The blue line represents force in x -axis, the red line represents force in y -axis in wheel coordinate system.	46	B.3 Test scenario no.2 - emergency braking under adverse road conditions. The conventional hydraulic ABS system.	60
7.5 Generated steering angles.	47	B.4 Test scenario no.2 - emergency braking under adverse road conditions. The hydraulic based ABS system with the drive-by-wire approach.	61
7.6 Generated forces on the wheels for $k = 1$. The blue line represents force in x -axis, the red line represents force in y -axis in wheel coordinate system.	47		

B.5 Test scenario no.1 - input reference tracking. Generated longitudinal slips.	62	B.15 Test scenario no.1 - input reference tracking. Generated longitudinal slips.	72
B.6 Test scenario no.2 - emergency braking for $k = 0.2$ using hydraulic ABS. Generated brake torques, wheel speeds and longitudinal slips.	63	B.16 Test scenario no.2 - emergency braking for $k = 0.4$ using Simscape regenerative ABS. Generated brake torques, wheel speeds and longitudinal slips.	73
B.7 Test scenario no.2 - emergency braking for $k = 0.2$ using brake by wire ABS. Generated brake torques, wheel speeds and longitudinal slips.	64	B.17 Test scenario no.3 - μ -split conditions, using Simscape regenerative ABS. On the left side $k = 0.2$, on the right side $k = 1$. . .	74
B.8 Test scenario no.2 - emergency braking for $k = 0.2$ using regenerative ABS. Generated brake torques, wheel speeds and longitudinal slips.	65		
B.9 Test scenario no.2 - emergency braking for $k = 0.4$ using hydraulic ABS. Generated brake torques, wheel speeds and longitudinal slips.	66		
B.10 Test scenario no.2 - emergency braking for $k = 0.4$ using brake by wire ABS. Generated brake torques, wheel speeds and longitudinal slips.	67		
B.11 Test scenario no.2 - emergency braking for $k = 0.4$ using regenerative ABS. Generated brake torques, wheel speeds and longitudinal slips.	68		
B.12 Test scenario no.3 - μ -split conditions, using hydraulic ABS. On the left side $k = 0.2$, on the right side $k = 1$	69		
B.13 Test scenario no.3 - μ -split conditions, using brake by wire ABS. On the left side $k = 0.2$, on the right side $k = 1$	70		
B.14 Test scenario no.3 - μ -split conditions, using regenerative ABS. On the left side $k = 0.2$, on the right side $k = 1$	71		

Tables

C.1 Vehicle body parameters. Adopted from [Cib19].	75
C.2 Parameters of used Simscape tandem master cylinder model. . . .	76
C.3 Parameters of used Simscape brake caliper system	76
C.4 Parameters of used electrical motor	76

■ List of Abbreviations

ABS	Anti-lock brake system
TMC	Tandem master cylinder
HCU	Hydraulic control unit
ECU	Electronic control unit
ESP	Electronic stability program
BBW	Brake by wire
BBS	Brake by steer
PMSM	Permanent magnet synchronous motor
FL	Front left wheel
FR	Front right wheel
RL	Rear left wheel
RR	Rear right wheel



Chapter 1

Introduction

Nowadays, a revolution is taking place in the automotive industry. Concepts like self-driving cars or drive-by-wire technologies are well known to the general public. Modern vehicles are equipped with tons of electronic assistant systems, which contribute to the greater comfort and safety of passengers. However, there are still areas where the automotive industry remains quite conservative. The brake system undoubtedly belongs to one of these areas. Nowadays, all passenger vehicles still use hydraulic brakes as a main brake system. However, some new drive-by-wire concepts, such as brake-by-wire, have been developed in the recent years. Only the time will show if some of these new concepts can push the conventional hydraulic brake system out of the automotive industry. In this thesis, the conventional and some new, recently developed, drive-by-wire based brake systems will be designed and compared.



1.1 Goals

The aim of this thesis is to develop several braking system control strategies. The objectives of this thesis are as follows:

- To adopt existing twin-track vehicle model and augment it with brake system components
- To develop several braking system control strategies
- To validate and compare developed brake control algorithms

Chapter 2

Vehicle model

In this chapter, used mathematical vehicle model will be introduced. The twin-track vehicle model is adopted from [Cib19]. Brief description of the used model is given below, for more detailed explanation of derivation see [Cib19]. The whole chapter is heavily based on [Cib19].

The twin-track model is divided into 3 main sections: chassis, vehicle body and powertrain. The original model has 16 states and 8 inputs. All states with dimension are listed below:

- s_E [3x1] - position of vehicle body in earth-fixed coordinates [m]
- v_v [3x1] - velocity of vehicle body in body-fixed coordinates [m/s]
- ω_v [3x1] - angular velocity of vehicle body in body-fixed coordinates [rad/s]
- ϕ, Θ, Ψ [3x1] - euler angles [rad]
- $\dot{\rho}_{R_i}$ [4x1] - wheel angular velocity in i^{th} wheel coordinates [rad/s].

Model inputs are:

- T_i - torque on i^{th} wheel [Nm]
- δ_i - steering angle on i^{th} wheel [rad].

For the purpose of this thesis, additional inputs are introduced - the brake torque on each wheel for braking and load force factor for each wheel to simulate different surfaces under each wheel. The modified model with complete list of inputs is below:

- T_i - torque on i^{th} wheel [Nm]

2. Vehicle model

- δ - steering angle on i^{th} wheel [rad]
- T_{b_i} - brake torque on i^{th} wheel [Nm]
- k_i - load force factor on i^{th} wheel [%].

As it can be seen from the list of the inputs, the twin-track model allows to drive all wheels independently in terms of torque and steering angle. Scheme of modified twin-track model can be seen in Figure 2.1.

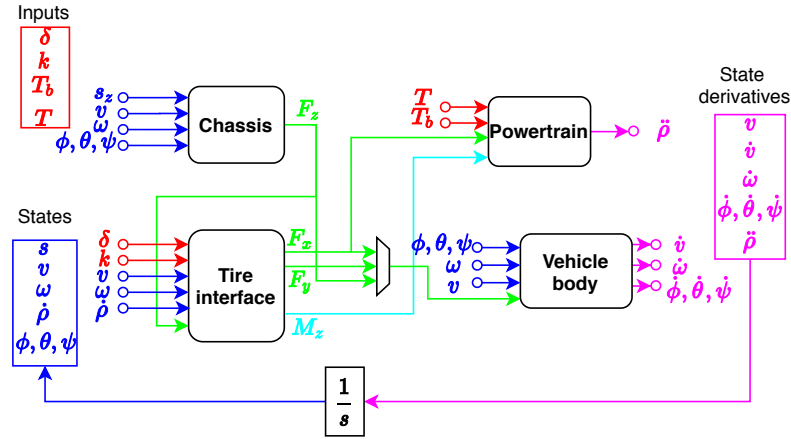

Figure 2.1: Scheme of modified twin-track model.

The vehicle model introduces 3 coordinate systems, earth-fixed, vehicle body-fixed and wheel-fixed coordinate system (each wheel has its own coordinate system). Orientation of these coordinate systems can be seen in Figures 2.2 and 2.3. For coordinate system transformation matrix see [SHB14]. The top view and the side view of the vehicle model is displayed in Figures 2.4 and 2.5.

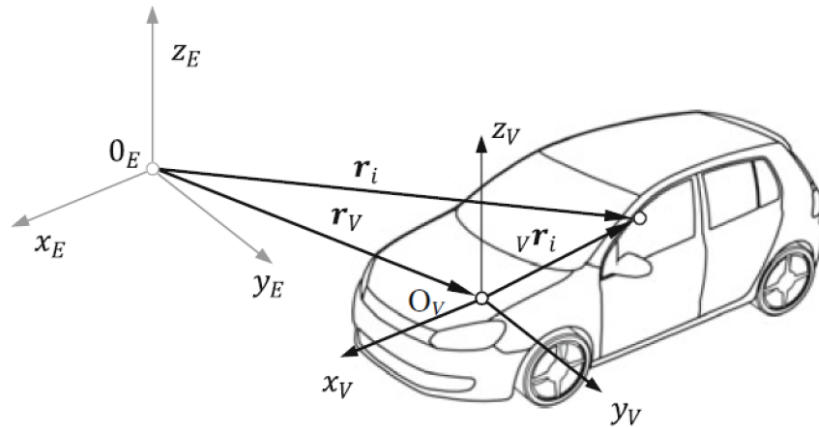

Figure 2.2: Earth-fixed and body fixed coordinate system. Adopted from [SHB14]

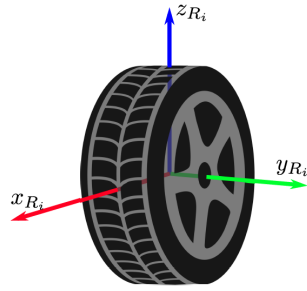

Figure 2.3: Coordinate system of i^{th} wheel. Adopted from [Cib19].

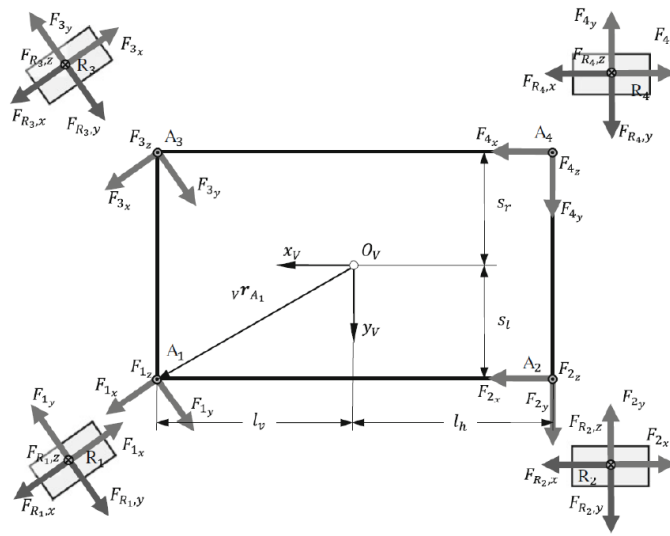

Figure 2.4: Top view of the vehicle model. Adopted from [SHB14].

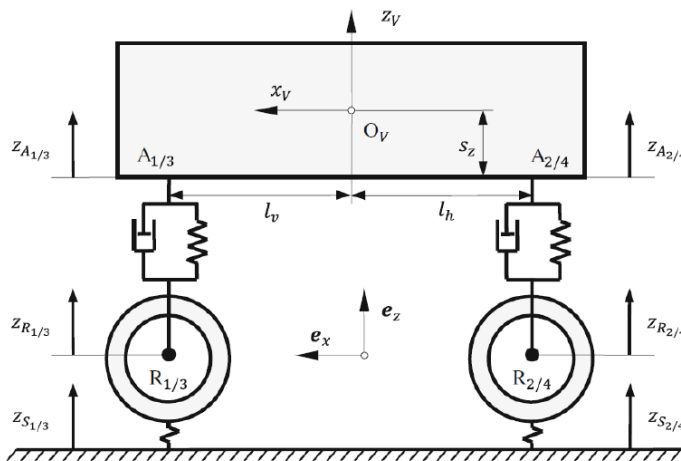

Figure 2.5: Side view of the vehicle model. Adopted from [SHB14].

2.1 Vehicle body

The vehicle body is modeled with Newton-Euler equations [Cib19]. The Newton equation is

$$m_v \left(\begin{bmatrix} \dot{v}_x \\ \dot{v}_y \\ \dot{v}_z \end{bmatrix} + \begin{bmatrix} \omega_x \\ \omega_y \\ \omega_z \end{bmatrix} \times \begin{bmatrix} v_x \\ v_y \\ v_z \end{bmatrix} \right) = \sum_{i=1}^4 \begin{bmatrix} \mathbf{F}_{i,x} \\ \mathbf{F}_{i,y} \\ \mathbf{F}_{i,z} \end{bmatrix} - \frac{1}{2} c_w \rho A \sqrt{v_x^2 + v_y^2} \begin{bmatrix} v_x \\ v_y \\ 0 \end{bmatrix} + {}^V \mathbf{T}_E \begin{bmatrix} 0 \\ 0 \\ -m_v g \end{bmatrix}, \quad (2.1)$$

where $\mathbf{F}_{i,x/y/z}$ are forces in the vehicle body coordinate system, ${}^V \mathbf{T}_E$ is transformation matrix from earth to vehicle coordinates and the middle term on the right side of the equation represents air-resistance (c_w is drag coefficient, ρ is air density and A is surface area exposed to air flow).

The Euler equation is as follows

$$\mathbf{J}_v \dot{\boldsymbol{\omega}}_v + \boldsymbol{\omega}_v \times (\mathbf{J}_v \boldsymbol{\omega}_v) = \mathbf{M}, \quad (2.2)$$

where \mathbf{J}_v is inertia matrix and \mathbf{M} is total torque acting on body.

For more detailed derivation of these equations, see [Cib19].

2.2 Chassis

Suspension

Description of suspension is omitted, see [Cib19] if interested.

2.2.1 Tire model

The twin-track model offers two tire models: Pacejka2002 and simplified Pacejka with friction ellipse. Both models take slip ration and slip angle as an input.

Slip variables

Longitudinal slip ratio is defined as

$$\lambda_i = \frac{v_{cx_i} - r \dot{\rho}_i}{\max(|v_{cx_i}|, |r \dot{\rho}_i|)}, \quad (2.3)$$

where v_{cx_i} is velocity of i^{th} wheel center in x direction in the wheel coordinates, r is wheel radius and $\dot{\rho}_i$ is angular velocity of i^{th} wheel.

Slip angle is defined as

$$\alpha_i = -\arctan\left(\frac{v_{cy_i}}{\max(|v_{cy_i}|, |r\dot{\rho}_i|)}\right), \quad (2.4)$$

where v_{cy_i} is velocity of i^{th} wheel center in y direction in the wheel coordinates, r is wheel radius and $\dot{\rho}_i$ is angular velocity of i^{th} wheel.

■ Simplified Pacejka

Simplified Pacejka Magic formula with constant coefficient [Pac12] is defined as

$$F(x) = DF_{z_i} \sin(C \arctan(Bx - E(Bx - \arctan(Bx)))), \quad (2.5)$$

where B, C, D, E are shaping coefficients, F_{z_i} is load force on i^{th} wheel, $F(x)$ is either F_x, F_y or M_z depending on the input x . Argument x is either slip angle α (for estimation of F_y and M_z) or slip ratio λ (for estimation of F_x).

To simulate different surfaces underneath the wheels, equation 2.5 has been modified as follows

$$F(x) = Dk_i F_{z_i} \sin(C \arctan(Bx - E(Bx - \arctan(Bx)))), \quad (2.6)$$

where k_i is the load force factor on i^{th} wheel.

Magic formula generates independent forces F_x and F_y , but in reality, these forces are always dependent. To obtain this dependency, a model with a friction ellipse is introduced. The friction ellipse is captured in Figure 2.6, F_{ymax} and F_{xmax} are given by equation 2.6, x-axis represents λ and y-axis represents α . For detailed explanation, see [Cib19].

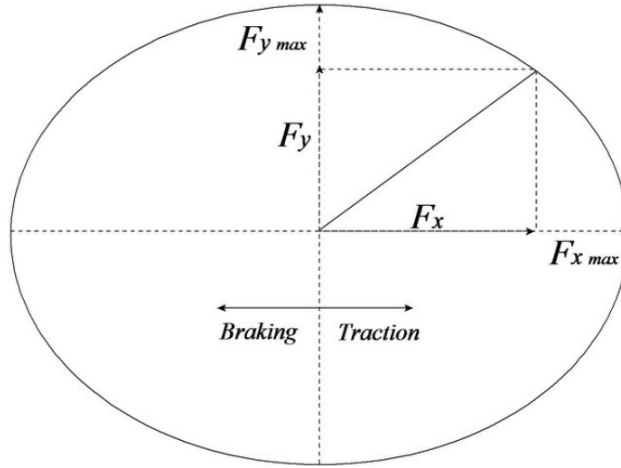

Figure 2.6: Friction ellipse for constant coefficient. Adopted from [Lib16].

2.3 Powertrain

Acceleration of i^{th} wheel is described by the following equation

$$J_{w_i} \ddot{\rho}_i = T_{d_i} - T_{b_i} \text{sign}(\dot{\rho}_i) - r_i F_{x_i}, \quad (2.7)$$

where J_{w_i} is i^{th} wheel moment of inertia, $\dot{\rho}_i$ is angular velocity of i^{th} wheel, T_{d_i} and T_{b_i} is driving and braking torque on i^{th} wheel, r_i is radius of i^{th} wheel and F_{x_i} is longitudinal force on i^{th} wheel in the wheel coordinate system.

Motor power is given by

$$P = T_{d_i} \dot{\rho}_i. \quad (2.8)$$

In the Simulink model, maximum power and torque limitations are implemented.

Chapter 3

Brake systems overview

The brake system is one of the most crucial systems for vehicle safety. For many years, the only requirement for a brake system was to reduce vehicle velocity or bring vehicle to halt. Nowadays, reducing velocity still remains a major requirement, but also other requirements must be taken into account for the brake system design. Some of these new requirements are:

- steerability under brake condition
- vehicle stabilization
- energy conservation - regenerative braking

To fulfill the requirements listed above, more complex brake systems are being developed and brake system design remains an active field of research. State-of-the-art of the brake systems, which are commonly used in automotive industry, and some new developing concepts will be described in this chapter.

3.1 Hydraulic brake system

The hydraulic brakes were invented in 1917 by Malcolm Loughead [Lou17]. In 1921, the hydraulic brake system was installed in a production car for the first time. From 1917 until now, many improvements have been made, but the basic working principle remains the same. Nowadays, hydraulic brakes are still the most common brake system used in automotive. They are so popular mostly because of their excellent price to performance ratio and their reliability. Also, hydraulic brakes have a long tradition and customers believe in them more than in alternative concepts such as brake-by-wire. The main advantages and disadvantages of hydraulic brakes are listed below.

- Advantages:
 - high reliability and safety
 - high redundancy in design provides great failure resistance
 - excellent price to performance ratio
- Disadvantages:
 - weight of the system
 - hydraulic transport delay
 - more complex design must be used for advanced brake control systems
 - kinetic energy of the vehicle is converted to heat energy and dissipated

There are two commonly used types of hydraulic brake systems: mechanical hydraulic brake systems and electro hydraulic brake systems.

■ 3.1.1 Mechanical hydraulic brake systems

The mechanical hydraulic brake system consists of the following parts [Gmb14]:

- brake pedal
- vacuum booster
- tandem master cylinder
- brake lines
- disc or drum brake.

Scheme of the described hydraulic brake system can be seen in Figure 3.1.

Brake pedal. Driver's force is applied on a brake pedal. The brake pedal is connected to input rod of the vacuum booster.

Vacuum booster. The vacuum booster uses vacuum created by the engine to amplify input force applied on the brake pedal. Amplified force is transferred to output rod, which is connected with the master cylinder.

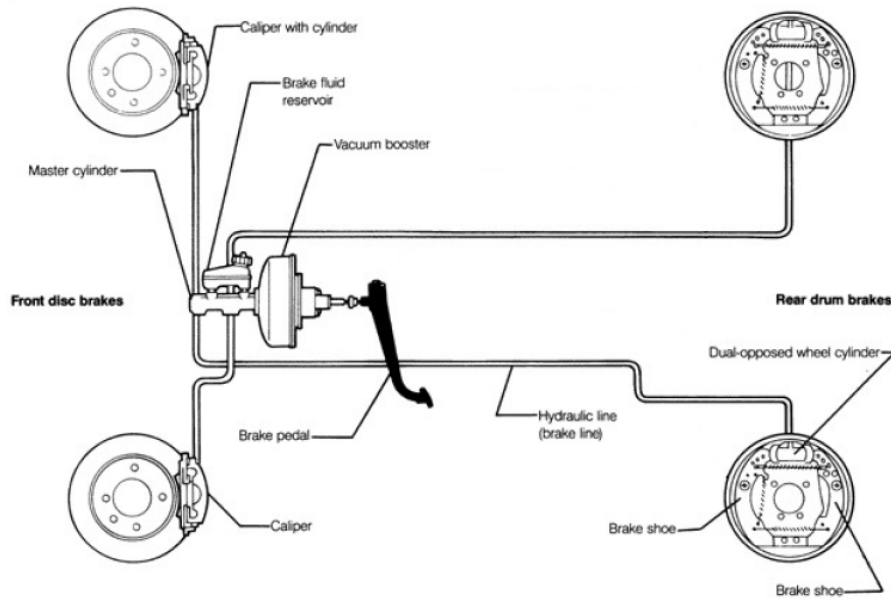

Figure 3.1: Scheme of the hydraulic brake system. Adopted from [vHNC14].

Tandem master cylinder. Tandem master cylinder (TMC) converts input force to hydraulic pressure. The TMC contains two in-line pistons, which are connected by rods and springs. Each piston pressurizes one braking circuit. Two piston design is used because of the safety reasons. If one of the pistons fails to build up pressure or there is a leakage in one of the brake circuits, the second piston still can build up pressure and the second brake circuit prevents the total failure of the brake system. Output of the TMC is connected to brake lines.

Brake lines. Brake lines are formed by brake pipes and brake hoses. The function of brake lines is to transfer brake fluid from the TMC to wheel cylinders. In most cases, there are two independent braking circuits in a passenger vehicle. One circuit is connected to front wheels, the other one is connected to rear wheels (parallel combination) or the first circuit is connected to the front left wheel and the rear right wheel and the second one vice versa (diagonal combination) [Gmb14]. These connections are used for safety reasons - in case of a leakage in one circuit, the second circuit still works normally, so half of the brake power can still be used.

Disc brake. Disc brakes are frictional brakes, which convert kinetic energy to heat. Brake line is connected to wheel cylinder, which transforms brake fluid pressure to force acting on brake pad. Brake pad pushes at rotor, which is connected to the wheel, and generates brake torque.

Drum brake. Nowadays, drum brakes are replaced by disc brakes in automotive industry, but they can still be found in older vehicles, especially on rear wheels. Drum brake consists of two main parts, a brake drum and a brake shoe. The working principle is pretty simple: the incoming brake fluid builds up pressure in the wheel cylinder. The wheel cylinder produces force acting on a brake shoe, which starts to push at a brake drum. This generates a friction between the drum and the shoe, which reduces wheel speed. Drum brakes are often used as a parking brake, the whole mechanism is operated by handbrake lever and handbrake cable [Gmb14].

The most basic form of a hydraulic system is described above. Main disadvantage of this system is that the brake force can only be applied by the brake pedal, so any advanced brake control system cannot be implemented. For implementation of the brake control system, such as anti-lock brake system (ABS), a more complex system has to be introduced. The modified mechanical hydraulic brake system allowing advanced brake control is displayed in Figure 3.2 (TMC, Hydraulic control unit (HCU) and vacuum booster are represented by hydraulic modulator block). In normal conditions, the brake power is controlled by the driver and if a wheel lock or any unwanted behavior occurs, the Electronic control unit (ECU) takes over and starts modulating brake pressure via HCU to achieve desired brake performance.

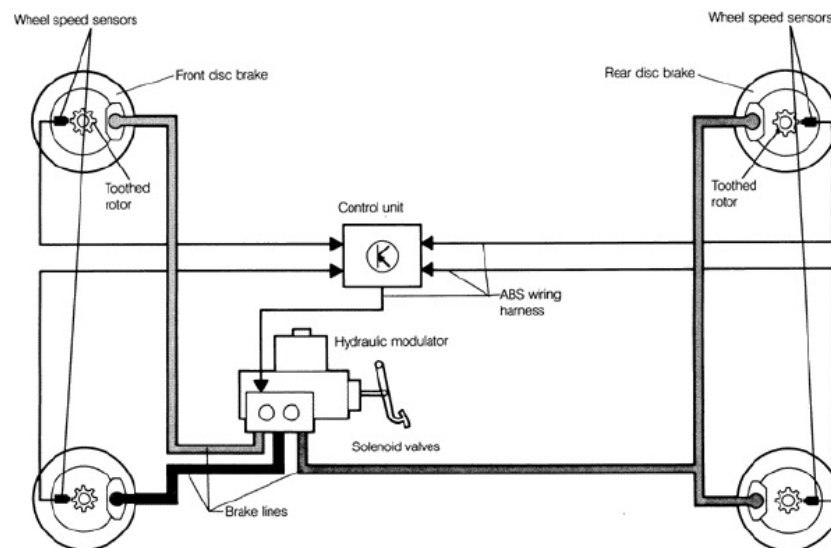

Figure 3.2: Scheme of the hydraulic brake system with hydraulic control unit. Adopted from [vHNK14].

Hydraulic control unit. The main function of this block is to control pressure in brake circuits independently on the driver's input. This block can increase, maintain or release brake pressure. Hydraulic control unit consists of solenoid

valves and electrically driven supply pumps, which control brake pressure. Solenoid valves and supply pumps are controlled by Electronic control unit.

Electronic control unit. Control systems such as ABS or ESP are implemented in the ECU. The ECU processes data from sensors and controls the HCU in order to reach desired brake performance.

Wheel speed sensor. The purpose of this sensor is to measure the angular speed of wheel. The measured data are sent to the ECU, where they are processed. The wheel speed sensor must be on each wheel.

■ 3.1.2 Electro hydraulic brake systems

The electro hydraulic brake system consists of mostly the same parts as the mechanical one. The main difference is that the TMC and the vacuum booster are replaced by a hydraulic modulator and there is not any mechanical connection between brake pedal and brake system itself in a normal operation mode. Scheme of the electro hydraulic brake system can be seen in Figure 3.3. The system contains following parts:

- brake pedal
- displacement and pressure sensors
- hydraulic modulator
- ECU
- brake lines
- disc brakes
- wheel speed sensor.

Displacement and pressure sensors. Displacement and pressure sensors measured position of the brake pedal. Measured data are sent to the ECU. Usually, two displacement and one pressure sensors are used. The reason for that are safety requirements. When one of the sensors fails, the remaining sensors still produce correct data for the ECU.

Hydraulic modulator. Hydraulic modulator consists of an electric motor and a hydraulic pump. The hydraulic modulator builds up pressure based on the ECU's demands. The built up pressure is transferred via brake lines to wheel cylinders.

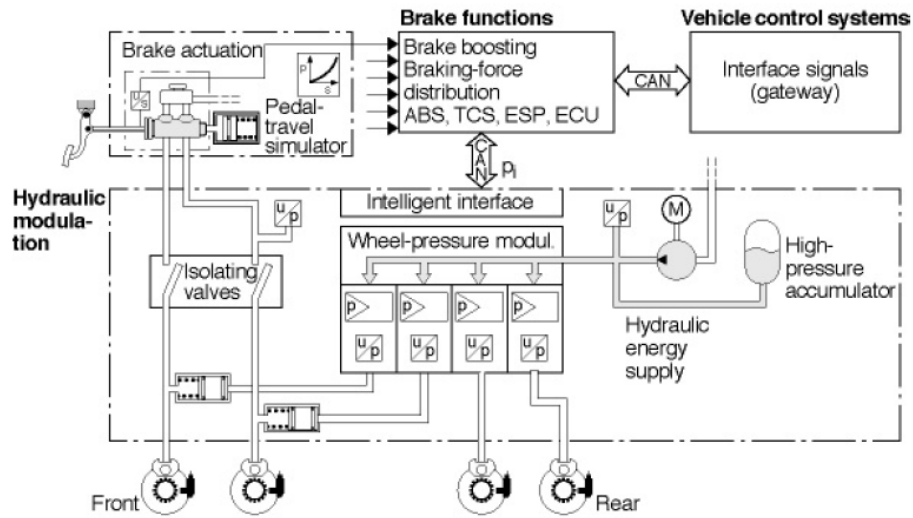

Figure 3.3: Scheme of the electro hydraulic brake system. Adopted from [Gmb14].

For safety reasons, the master cylinder is preserved in design. When a system failure, like power-supply failure, occurs, isolating valves (see Figure 3.3) are opened and the master cylinder is connected to the brake circuit. When isolating valves are open, the force applied by the driver is directly converted to hydraulic pressure by the master cylinder and transferred to brakes.

Advantages. In a normal operation mode, the input force applied on the pedal by the driver does not build up brake pressure directly. Driver's demand is processed by the ECU first. The ECU creates force feedback on the pedal and regulates driver's demand to ensure that generated brake force will be in compliance with the requirement of ABS or another stability control system implemented in the ECU. This allows faster and more accurate control of the generated brake force than the mechanical hydraulic system does.

Disadvantages. The main disadvantage is redundancy in the system. Because there is no physical connection between the brake pedal and the hydraulic modulator, redundant sensors and data processing must be used to ensure the function of the brake system, when failure occurs. Also, for safety reasons, the master cylinder has to be preserved in design.

Because the safety requirements, complexity and cost of the system increase, this system is not so commonly used like the mechanical one. The electro hydraulic brake systems can be found in some Mercedes-Benz or Toyota cars under names SBC or EHB [vHnk14].

3.2 Regenerative brake system

The main idea behind the regenerative brake system, also known as recuperation, is to save some kinetic energy, which is transferred to heat by the conventional friction-based brake systems. During braking, vehicle's kinetic energy is transferred to electric energy by an electric generator. The electric motor is commonly used as the electric generator, so regenerative brake system can be found only in electric or hybrid vehicles. When vehicle is accelerating, the electric motor is in motor mode and produces driving torque. When vehicle starts braking, the motor switches to generator mode and wheel's energy is transformed into electrical energy. Generated electrical energy is stored in the battery system.

Advantages. The greatest benefit is restoring some portion of vehicle's kinetic energy, which can be reused. This leads to increasing vehicle's range. Another benefit is the reduction of brake dust and emissions [Gmb14].

Disadvantages. The brake torque generated by recuperation is limited, so the regenerative brake system has to be combined with conventional brakes to satisfy safety regulations. Moreover, regenerative brakes do not work at low speed or when the car is stationary (minimal power level for generator is needed). Also at a high speed, the amount of available torque is limited due to the maximal power of the generator. Another issue is that the maximal available brake torque is dependent on vehicle speed and the state of battery charge [Gmb14].

To satisfy safety requirements, the regenerative brake system must always be used together with a conventional brake system and a quite complex control of brake torque distribution must be implemented in the ECU. Still, the regenerative brake system has more benefits than limitations and can be found in every hybrid or electrical car on the market nowadays.

3.3 Brake-by-wire

Brake-by-wire, together with steer-by-wire, is a part of the recently developed concept in automotive industry called drive-by-wire. The drive-by-wire concept is new in automotive, but in aviation, from where it was adopted, it has been used for almost fifty years. The main idea of the drive-by-wire concept is to replace mechanical connection with electronic sensors and actuators. In the brake-by-wire system, there is no connection between the brake pedal and the brake system itself. Information between the brake pedal, the ECU and brakes is transferred as electronic signals. Two types of brakes are distinguished, electro hydraulic and electro mechanical system. The brake

system described in chapter 3.1.2 can be considered as an electro hydraulic system.

■ 3.3.1 Electro mechanical brake system

The electro mechanical brake system design eliminates all hydraulic components. The system consists only of electronic and mechanical components. An example of the brake-by-wire electronic actuator system is displayed in Figure 3.4. The list of components follows

- brake pedal
- displacement and pressure sensor
- ECU
- electric motor with gearbox
- wheel speed sensors

Electric motor with gearbox. The electric motor is driven directly by the ECU. Motor generates torque which is converted to linear motion by rotary-linear gearbox mechanism (e.g screw-nut mechanism can be used). Gearbox output rod is connected to brake pads. Motor applies force on brake pads, which push at brake rotor and generate brake torque.

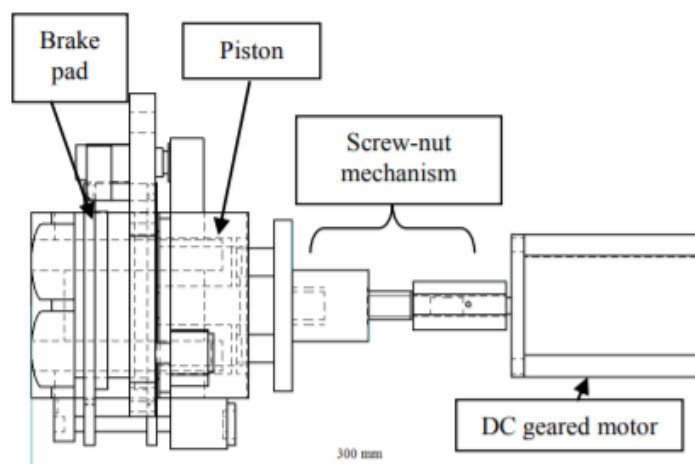

Figure 3.4: Scheme of the brake-by-wire actuator. Adopted from [MK14].

Advantages. The absence of hydraulic components results in a faster system response, saves the overall vehicle weight and there is no hydraulic transport

delay in the system as well. Also, the electrical connection allows an independent and more sophisticated brake torque control on each wheel, which leads to more safe and reliable brake system.

Disadvantages. Unfortunately, the absence of a physical connection between pedal and brakes introduces some new issues, which need to be solved. The main problem is poor fault tolerance. In case of an electrical system failure (e.g power-supply failure), there is no way to generate any brake torque.

To satisfy legal safety requirements for a brake system, a backup brake system must be introduced. There are three possibilities:

- conventional hydraulic brake system
- two electro mechanical brake systems which will be entirely independent - this solution is expensive and quite complex
- brake-by-steer concept described below.

Because of this safety redundancy issue, electro mechanical brake system is not used in any production car on the market.

■ 3.4 Brake-by-steer

Brake-by-steer (BBS) is a new concept that can be used on a vehicle equipped with steer-by-wire technology. The idea behind this concept is to turn wheels against each other in a snow plow position to reduce vehicle velocity. The illustration of the working principle is captured in Figure 3.5a.

The original idea was to develop an independent brake system which can be used as an alternative to the conventional, friction based, brake system. Let's assume that the vehicle is going straightforward and the same load force acts on both of the wheels on each axle. Turning wheels against each other induces lateral force acting on every wheel. A part of this force is transformed to longitudinal force acting on vehicle, so the vehicle starts decelerating. The remaining part is transformed to lateral force acting on vehicle body. Because the contribution of lateral force from the left and the right wheel is the same, these contributions cancel each other and no lateral force is acting on the vehicle body. All of the forces are displayed in Figure 3.5b.

The relation between lateral force acting on wheel and longitudinal and lateral forces acting on the vehicle body is following

$$F_{long_{vehicle}} = \sin(\delta_i) F_{lat_{wheel}} \quad (3.1)$$

$$F_{lat_{vehicle}} = \cos(\delta_i) F_{lat_{wheel}} \quad (3.2)$$

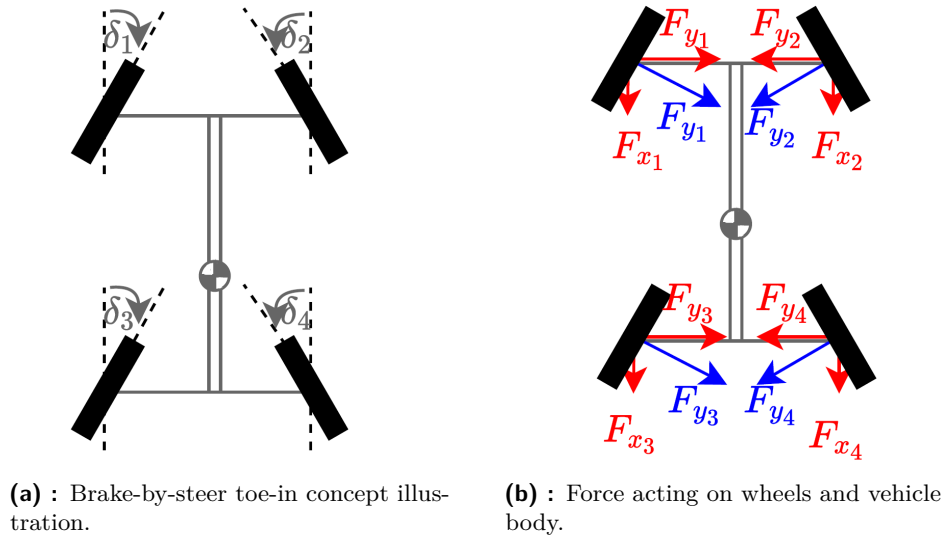

Figure 3.5: Brake-by-steer concept.

From equations 3.1 and 3.2, it can be seen that for small steering angles δ_i , most of the force is generated in lateral direction. Let's assume that maximum steering angle is set to 10 degrees. That means that only 17% of induced lateral force on wheel is used as a braking force. Moreover, great lateral forces acting on wheels cause that the tires wear out faster. For better brake performance, maximum steering angle must be increased. However, increasing maximal steering angle does not solve the problem with wear out of the tires and introduces more problems with vehicle stability and steer response. Mostly because of greater wear out of the tires and poor brake performance for small steering angles, the brake-by-steer concept seems to be a dead end. The idea of an independent brake-by-steer system has to be abandoned, but the idea from [Jan10] was adopted.

The main idea of [Jan10] is to use the brake-by-steer as a backup emergency brake system. The vehicle is equipped with conventional brake or brake-by-wire system, which is primarily used. When a fatal failure of the primary brake system occurs, the brake-by-steer system is activated. In emergency situations, there is no need to care about efficiency or wear out of the tires, therefore steering angles greater than 10 degrees can be used.

This approach offers a solution for the brake-by-wire safety and reliability issues. When both concepts are used together, desired safety requirements can be achieved without introducing any additional system, which leads to cost reduction. Also, the brake-by-steer system can be used together with a conventional hydraulic brake system to increase passengers' safety when a fatal failure in the hydraulic system occurs.

Only the toe-in (both wheels go inward) configuration is implemented in this thesis. If interested in toe-out or asymmetric toe design analysis, see [Jan10]. More about the BBS system design can be found in Chapter 7.

Chapter 4

Implementation of the brake subsystems

In this chapter, the implementation of three brake subsystems will be described. All of them are implemented in Matlab and Simulink environment. The implemented subsystems are based on existing Matlab Simscape models, which were adopted and modified. Following subsystems are implemented

- hydraulic brake system
- in-wheel electric motor for regenerative brake system
- mechatronic brake actuator for brake-by-wire system.

4.1 Hydraulic brake system

Design of the hydraulic brake system is based on the Simscape example named "Fixed Caliper Disc Brake" [MAT19]. The original model consists of the tandem master cylinder and fixed caliper disc brake blocks. Model's input is force applied on the tandem master cylinder, model's outputs are brake torques acting on all four wheels.

In order to make hydraulic system compatible with the twin-track model, some modifications of the system design have to be done. The greatest modification is introduced in the fixed caliper disc brake subsystem, where additional system input for wheel velocity is introduced. For simplification, it is assumed that all disc brakes, brake lines and pistons are identical, therefore generated torque is the same for each wheel. To make the whole system more realistic, hydraulic lines are made from the hydraulic resistive tube elements. The design of the tandem master cylinder is left unmodified. Finally, input force is scaled to obtain unity gain of the whole subsystem, so reference torque can be used as an input. The maximal generated brake torque is limited to 1190 Nm. Modified caliper disc brake subsystem is captured in Figure 4.1.

4. Implementation of the brake subsystems

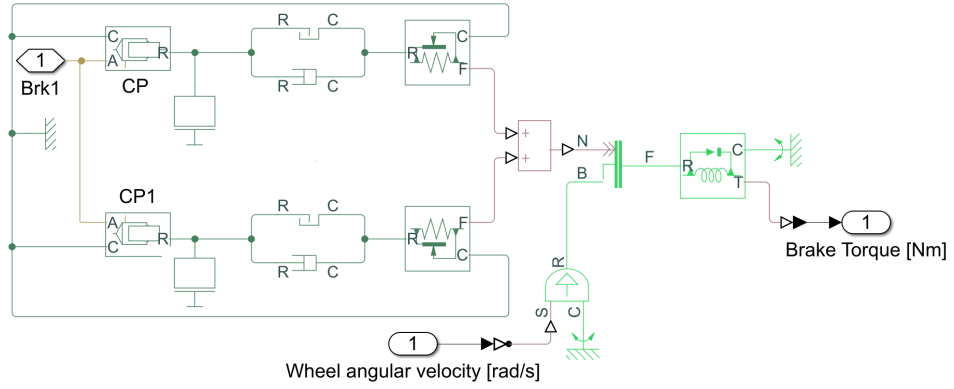

Figure 4.1: Scheme of the modified fixed caliper disc brake subsystem.

The parameters of used hydraulic brake system can be found in Tables C.2 and C.3 in Appendix C. Response of the hydraulic brake system for step inputs is displayed in Figure 4.2.

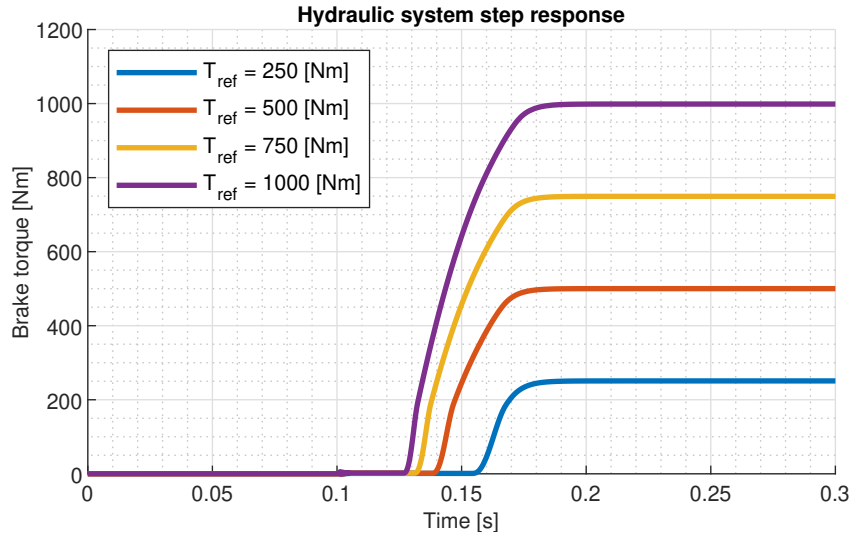

Figure 4.2: Step response of hydraulic system for step time 0.1 s.

For controller design, a system identification is needed. In Figure 4.2, it can be seen that the hydraulic transport delay is dependent on the system input. For simplification, uniform transport delay is used in the system identification. The hydraulic brake system is approximated by the second order transfer function with transport delay

$$G(s) = e^{-0.037s} \frac{16136}{s^2 + 244.1s + 16136}. \quad (4.1)$$

For the needs of ABS controller design, let's assume that the whole hydraulic brake system consists of these four hydraulic subsystems, so each wheel can

be controlled independently. More about ABS controller design can be found in Chapter 6. Validation of the system identification is captured in Figure 4.3.

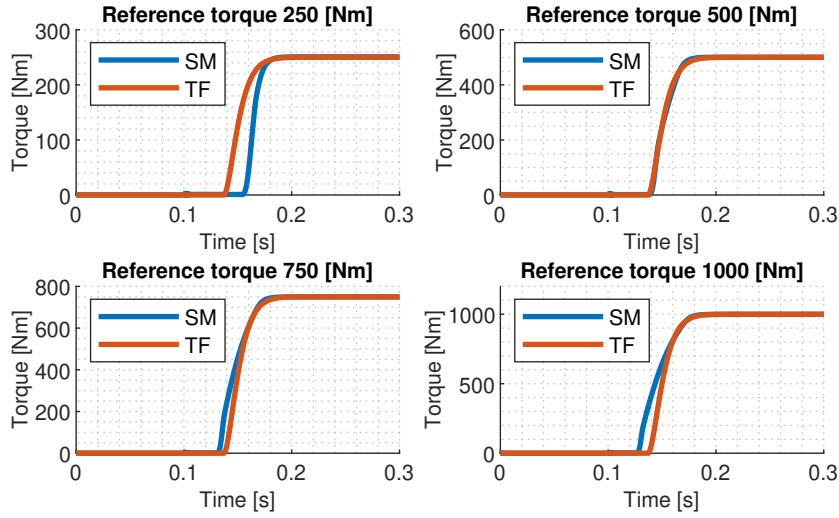

Figure 4.3: Comparison of Simscape model (SM) and identified system transfer function (TF) step response for step time 0.1 s.

4.2 In-wheel electric motor for regenerative brake system

The model of an in-wheel electric motor for regenerative brake system is based on the Simscape example named "Three-Phase PMSM Drive" [MAT19]. The model consists of Permanent Magnet Synchronous Motor (PMSM), three-phase inverter and PMSM controller with closed-loop torque control. Parameters of the motor can be found in Table C.4 in Appendix C. Because this model is not suitable for complete vehicle simulation (mostly because of a long simulation time and high memory demands), the original model is replaced by a subsystem with Simplified PMSM drive block, which is displayed in Figure 4.4. Finally, the system identification needs to be done. The system is approximated by the first order transfer function

$$G(S) = \frac{1.0098}{0.00189s + 1}. \quad (4.2)$$

The step response of both of the motor models and the identified system can be seen in Figure 4.5.

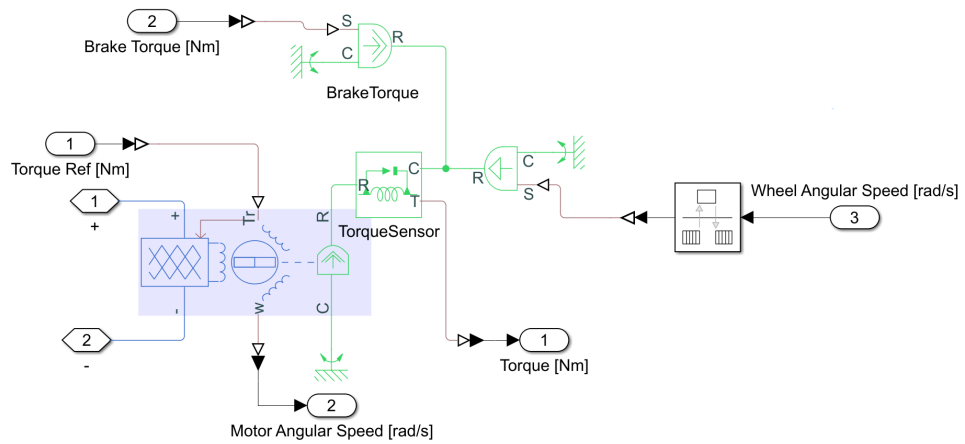

Figure 4.4: Scheme of the implemented motor system.

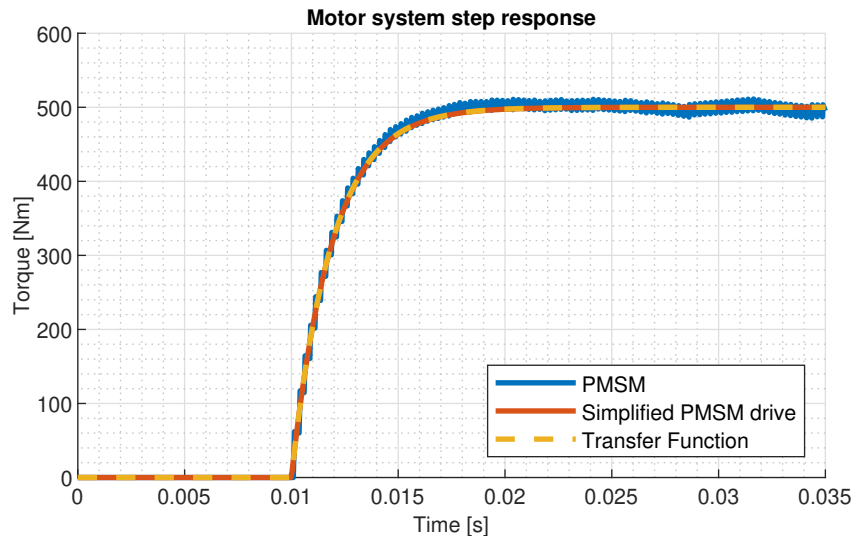

Figure 4.5: Step response of in-wheel motor system for step time 0.01 s and step input 500 Nm.

For purposes of the twin-track model with Simscape (more about this model is in Chapter 6), a powertrain block is formed. The powertrain block consists of a basic battery system, which is formed by a Simscape DC battery block, and four in-wheel electric motor subsystems captured in Figure 4.4.

4.3 Mechatronic brake actuator for brake-by-wire

The mechatronic actuator consists of an electric motor with rotary-linear gearbox mechanism and a disc brake. Fixed caliper disc brake subsystem from 4.1 is reused as a disc brake. The hydraulic input of the disc brake system

Chapter 5

Anti-lock brake systems

The main purpose of the anti-lock brake system is to prevent wheel lock and retain vehicle's stability and steerability under braking condition. The first production ABS system was developed in 1978 [Gmb14] and the ABS systems can be found almost in every passenger vehicle on the market nowadays. The requirements, which the ABS system must fulfill, are listed below

- prevent wheel-lock
- retain vehicle's steerability and stability
- reduce stopping distance
- quick adjustment of the brake torque to different friction coefficients
- operate under adverse road conditions.

5.1 Anti-lock brake system overview

The ABS is a closed-loop control system. The operating principle is the following. The wheel speed sensors measure peripheral speed of each wheel. The measured data are sent to the ECU. The ECU evaluates data from wheel speed sensors and the hydraulic control unit controls brake pressure. The ECU counts relative difference between wheel speed and vehicle speed. According to the result, the hydraulic control unit releases, maintains or increases brake pressure. As an alternative to wheel speed, a longitudinal slip can be used. In this case, the ECU compares measured longitudinal slip with maximal allowed slip value, which is normally between 0.15 – 0.2. However, this approach is not commonly used because the longitudinal slip cannot be measured directly. Because the ABS system is crucial for vehicle safety, a fault tolerance must be implemented. The ABS controller is dependent on

wheel speed measurement, therefore safety redundancy in measurement must be ensured.

To fulfill requirements on lateral stability, several approaches are introduced. The lateral force and yaw moment occur, when different brake forces act on the left and the right wheel on each axle. This can be caused by a different load on each wheel or by a different surface friction coefficient beneath the wheels (also known as a μ -split condition). There are two variants of the ABS control system commonly used in automotive industry

- 4-channel systems
- 3-channel systems.

4-channel systems. This variant allows an independent control of brake torque on all four wheels. Each wheel must have its own wheel speed sensor. This approach offers the best brake performance and an easy lateral stability control. The disadvantages are mainly the cost and the number of needed components.

3-channel systems. This variant uses independent wheel speed sensors on front wheels and one shared speed sensor in the rear differential. Brake torque on rear wheels is the same in this configuration. To ensure lateral stability, a select-low control must be used on the rear axle. Select-low control means that the wheel with lower grip sets brake torque value applied on both of the wheels, so the wheel with higher grip is braked less. The advantage of this variant is a smaller number of needed components and a lower cost compared to the 4-channel system. The disadvantage is worse brake performance compared to the 4-channel system.

Chapter 6

ABS systems design

The system design and architecture of the proposed anti-lock brake systems (ABS) will be described in this chapter. First of all, behaviour and properties of the conventional ABS and drive-by-wire approaches are discussed. Then the hydraulic ABS system is implemented and compared with the proposed brake-by-wire ABS system and the regenerative brake-by-wire ABS system. Finally, the regenerative brake-by-wire ABS system using the Simscape models presented in Chapter 4 is designed. The design, validation and comparison of all implemented systems are discussed in this chapter.

6.1 Proposed control approaches

First of all, the conventional ABS system and drive-by-wire control system with direct wheel speed control are implemented to determine their behaviour and to compare their properties. Both of the ABS systems are based on the hydraulic brakes. These systems are quite simple and implemented mostly for comparison purposes, but they can be used as a simple standalone ABS systems as well.

6.1.1 Conventional ABS approach

The block scheme of the designed conventional ABS system with longitudinal slip control is depicted in Figure 6.1. The input of the system is reference vehicle acceleration, the outputs are brake torques applied on the wheels. The designed system consists of two closed-loop controllers. The outer closed-loop controller takes the error between reference vehicle acceleration and actual vehicle acceleration as an input. The output of the controller is the reference longitudinal slip. The reference longitudinal slip is saturated to -0.15, which corresponds to the maximal friction coefficient for most of the surfaces (see Figure 6.2). The inner control loops regulate brake torque on the given wheel.

The input of inner control loop is error between counted reference longitudinal slip and measured longitudinal slip on given wheel. To ensure lateral stability, the select-low principle is used. Note that the select-low is modeled by max function block because the brake torque is always negative. All closed-loops are regulated by PI controllers, which are represented by the Simulink PID blocks. All controllers are tuned by the Ziegler-Nichols method and by hand. The remaining blocks of the designed ABS system are described below.

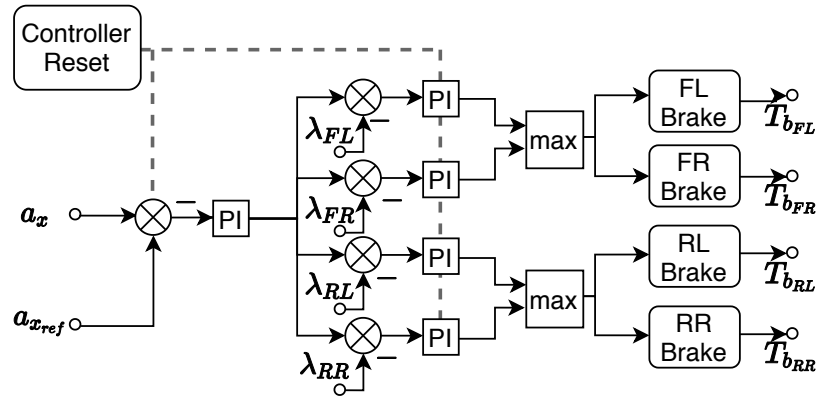

Figure 6.1: Block scheme of the conventional ABS system.

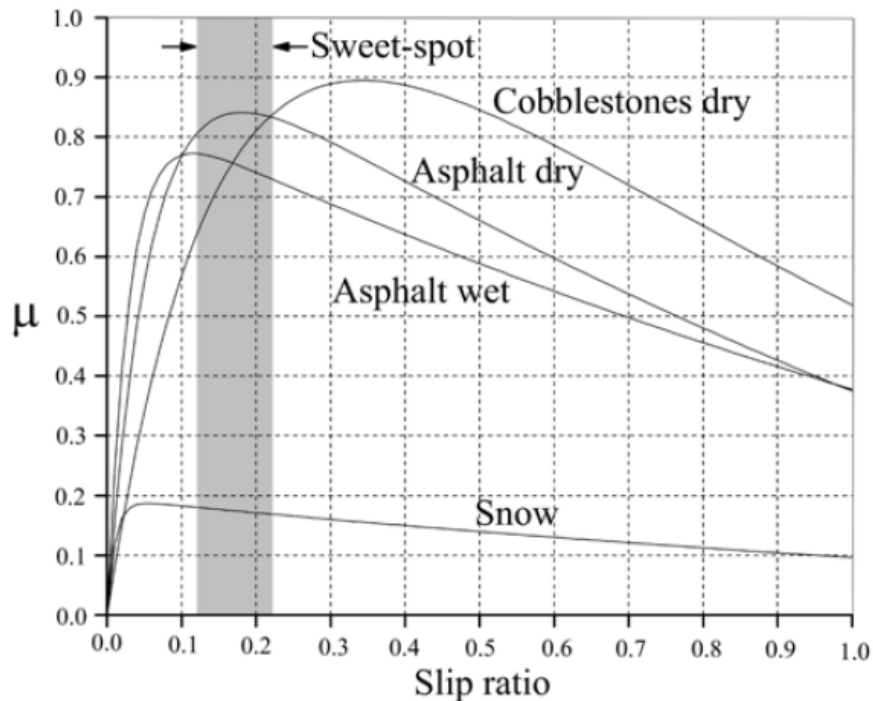

Figure 6.2: Friction coefficient curves for different surfaces. Adopted from [BBS11]. Note that the twin-track model defines negative slip ratios for braking.

Brake block. The brake block represents the hydraulic brake, derived in Chapter 4. The Simulink block scheme of this block can be seen in Figure 6.3.

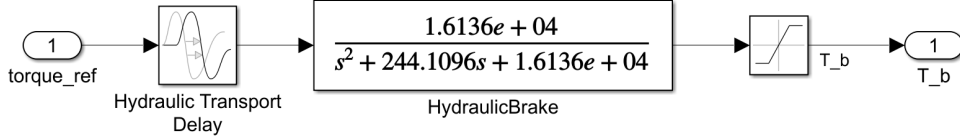

Figure 6.3: Simulink block scheme of the used hydraulic brake system.

ControllerReset. This block is used as a very simple anti-windup filter. The main function of this block is to reset all controllers, when a decreasing step change in the reference acceleration input occurs. The reset of the controllers is needed to prevent windup effect, which is introduced by the PI controllers.

6.1.2 Drive-by-wire approach

The drive-by-wire approach is based on a direct wheel speed control. The main advantage of this approach is that the ABS functionality is an inherent part of the proposed drive-by-wire system. The block scheme of this ABS system is captured in Figure 6.4. Design of the ABS system is formed by two closed-loop controllers as well. Reference vehicle acceleration is used as a system input, the outputs of the systems are brake torques on the wheels. The outer loop takes error between reference vehicle acceleration and real vehicle acceleration as an input. The output of the controller is the reference longitudinal slip. Again, maximal value of the reference longitudinal slip is limited to -0.15. The reference slip goes in the $\lambda 2\omega$ block, where the reference wheel angular speed is determined. The inner control loop consists of four controllers, which regulate brake torque on the given wheel. The difference between counted reference wheel speed and actual wheel speed is used as an input. Again, to maintain the lateral stability, the select-low control is used. Both of the closed-loops are controlled by the PI controllers, which are tuned by the Ziegler-Nichols method and by hand. Function of the $\lambda 2\omega$ block is described below.

$\lambda 2\omega$. This block realizes the calculation of reference angular speed for each wheel. The dependency between longitudinal slip and wheel angular speed is given by the equation

$$\omega_{ref_i} = \frac{v_{x_i}(1 + \lambda_{ref_i})}{r_i}, \quad (6.1)$$

where v_{x_i} is speed of a wheel mounting center in x -direction and r_i is radius of i^{th} wheel. Note that the reference angular wheel speed is the same for all wheels in this system.

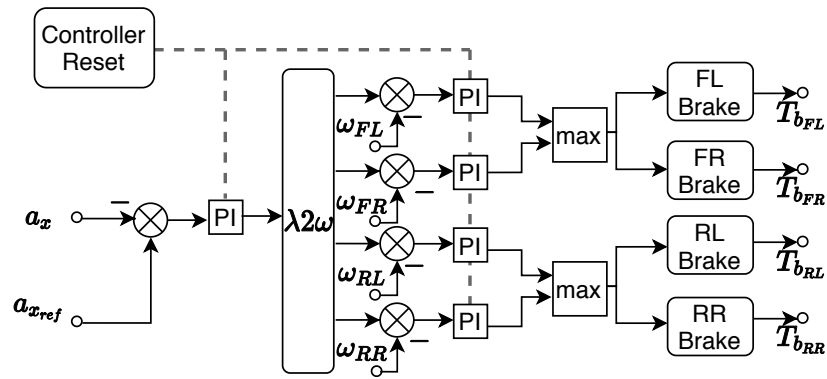

Figure 6.4: Block scheme of the drive-by-wire system.

6.1.3 Comparison of conventional ABS and drive-by-wire approach

For validation and comparison of both of the suggested ABS systems, the following tests are performed.

Test 1 - Reference tracking

In this scenario, the reference signal tracking quality is examined. The load force factor k is set to 1 for each wheel to simulate normal road conditions and the vehicle goes straightforward. The initial speed of the vehicle is set to 100 km/h. The reference acceleration course is depicted in Figure 6.5.

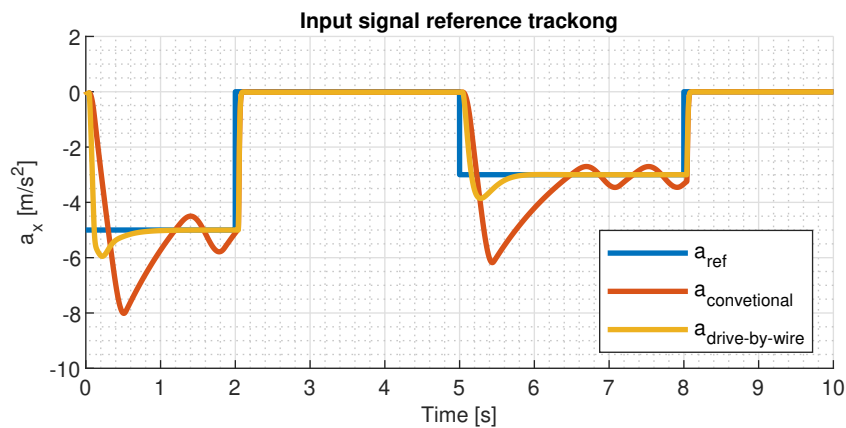

Figure 6.5: Comparison of reference input signal tracking.

In Figure 6.5, it can be seen that the system with the drive-by-wire approach settles faster and overshoots less than the conventional ABS approach.

■ Test 2 - Emergency braking

The second test simulates emergency braking under adverse road conditions. The vehicle is going straightforward and the load force factor k is set to 0.3 for each wheel to simulate adverse road conditions. The initial speed of the vehicle is set to 100 km/h, the reference acceleration is set to -10 m/s^2 , which corresponds to full braking. In Figure 6.6, it can be seen that braking distance of the drive-by-wire based ABS system is slightly shorter.

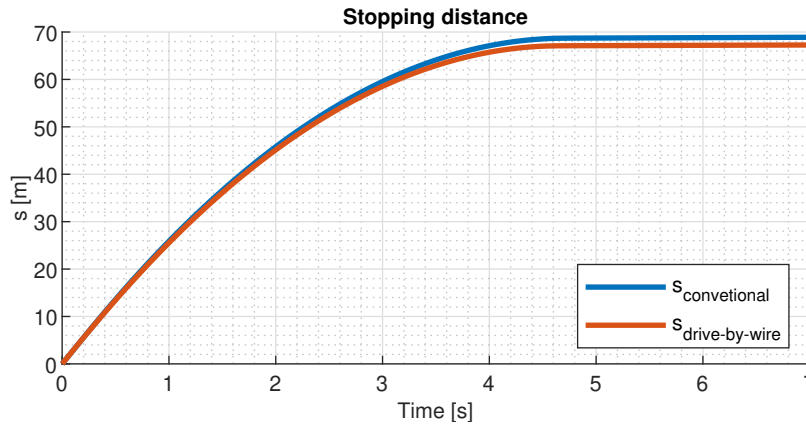

Figure 6.6: Comparison of stopping distance for fully braking under adverse road conditions.

Both performed tests show that the drive-by-wire approach offers faster and better control and is more suitable for further design. More detailed graphs showing brake torques, longitudinal slips and wheel speeds generated in both performed tests can be seen in Appendix B in Figures B.1 - B.4.

■ 6.2 Standalone ABS system

Now, more complex, standalone ABS system will be designed. All designed systems are based on the drive-by-wire approach, which is more suitable as the tests performed above prove. First of all, the hydraulic ABS system is designed. This hydraulic system is used as a reference against which the proposed brake-by-wire and regenerative ABS systems will be compared.

■ 6.2.1 Hydraulic ABS system

The block scheme of the designed hydraulic ABS system is depicted in Figure 6.7.

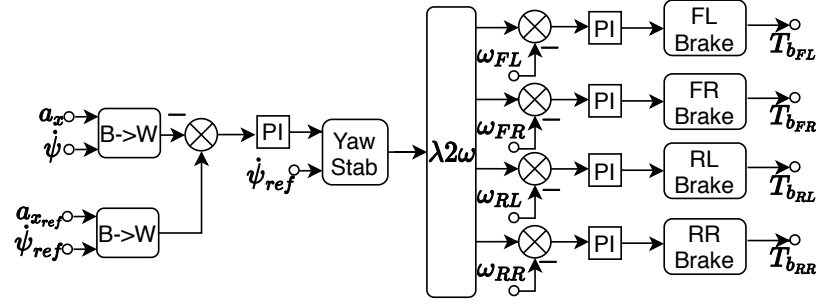

Figure 6.7: Block scheme of the hydraulic ABS.

The designed system consists of two closed-loops. Each closed-loop contains four controllers, therefore brake torque on each wheel can be regulated independently. The outer control loop takes the error between reference wheel acceleration in wheel coordinates and actual wheel acceleration in wheel coordinates as an input. The transformation between vehicle and wheel coordinates is carried out by **B->W** block. The output of the outer loop controller is the reference longitudinal slip. Note that the input and output of the controller is a 1x4 vector. The reference longitudinal slips enter in **YawStab** block, which modifies reference slips in order to ensure lateral stability. The modified reference longitudinal slips enter in the $\lambda 2\omega$ block, where wheel angular speed for each wheel is determined. The inner closed-loop controllers take error between reference wheel speed of the given wheel and actual wheel speed of the given wheel as an input. The output is reference brake torque of the given wheel. To satisfy safety requirements, **WheelSpeedSensorSafetyCheck** and **EmergencyAbsTurnOff** blocks described below are introduced. All controllers are of a type PI and are represented by Simulink PID block. The **ControllerReset** block described above is used as a simple anti-windup filter again. More detailed description of used blocks and subsystems follows.

B->W. The function of this block is to transform vehicle acceleration from vehicle body coordinates to wheel coordinates. The equations describing the transformation follow

$$a_{wheel_{left}} = a_{vehicle} - \ddot{\Psi}y_l \quad (6.2)$$

$$a_{wheel_{right}} = a_{vehicle} + \ddot{\Psi}y_l, \quad (6.3)$$

where y_l is the distance between the center of wheel mounting and the vehicle body center in y -axis and $\ddot{\Psi}$ is the second derivative of the Yaw angle. Note that these two equations are only valid for zero steering angles.

YawStab. The main function of this block is to ensure lateral stability of the vehicle under braking conditions. This block introduces additional four closed-loop PI controllers, which regulate reference longitudinal slips. The

error between actual and reference yaw rate is taken as an input, the output is longitudinal slip which is subtracted from the reference longitudinal slip.

ControllerOnOff. This block turns off all controllers, when reference vehicle acceleration is greater than or equal to zero.

WheelSpeedSensorSafetyCheck. The inner control loop is dependent on the angular wheel speed measurement. When the measured data are incorrect or even the wheel speed sensors stop working completely, the behaviour of the ABS system is undefined and can even be quite dangerous. To solve possible wheel speed sensor failures, this block is implemented. The main function of this block is to detect sensor failure and report it. The angular wheel speed from the sensor is compared with the angular speed of the wheel, which is given by the equation

$$\omega_{wheel} = \frac{v_{x_{mounting}}}{r}, \quad (6.4)$$

where r is the wheel radius and $v_{x_{mounting}}$ is speed of the wheel mounting center in x -direction. When the difference between speeds exceeds threshold, the failure is detected and the **EmergencyAbsTurnOff** subsystem turns off the ABS system and the driver is informed that the ABS system is disabled.

EmergencyAbsTurnOff. The function of this block is to turn off the ABS system when a failure is detected. This block is a part of the **BrakingSystem** subsystem. Under normal conditions, the reference brake torque determined by closed-loop controllers is applied to the wheels. When an error occurs, the ABS closed loop system control is turned off and the brake force applied by the driver is directly transmitted to the wheels.

6.2.2 Brake-by-wire ABS system

The design of the brake-by-wire ABS system is the same as the design of the hydraulic ABS system. The only differences are that the hydraulic brakes are replaced by the brake-by-wire brakes and the **ControllerReset** block is replaced by the implemented anti-windup filter. Again, all controllers are of a type PI.

Anti-windup filter. The block scheme of the PI regulator with the anti-windup filter is depicted in Figure 6.8. The anti-windup filter used in the inner loop takes the difference between reference brake torque and real brake torque applied by brakes as an input. When this difference exceeds preset threshold, the input of the integrator is switched to zero to prevent saturation. When the difference is lower than the preset threshold, the input of the integrator is switched back to the input signal of the controller. The anti-windup filter

used in the outer control loop works similarly. The only difference is that the input of the integrator is switched to zero when the difference between reference longitudinal slip and saturated slip exceeds preset threshold or when the input of the integrator of the inner loop is set to zero.

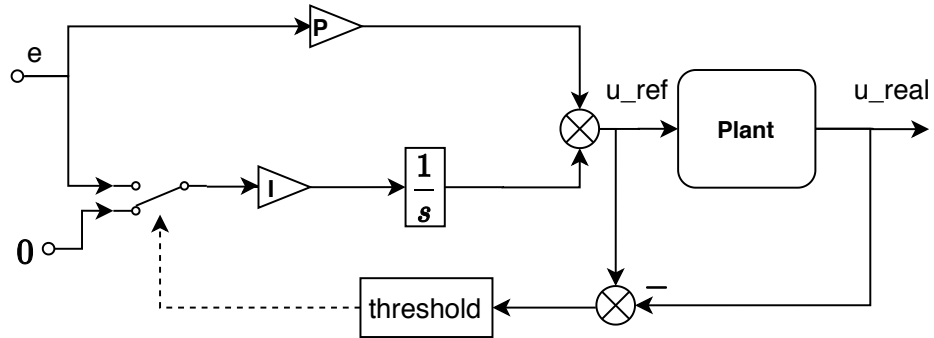

Figure 6.8: Scheme of the PI regulator with anti-windup filter.

6.2.3 Regenerative ABS system with brake-by-wire

The design of the regenerative ABS system is based on the brake-by-wire ABS system design. The only difference can be found in the **BrakingSystem** blocks, where the reference brake torque is distributed between the electric motor and the friction based brake. The block scheme of the modified **BrakingSystem** block is depicted in Figure 6.9. Description of the modified system follows.

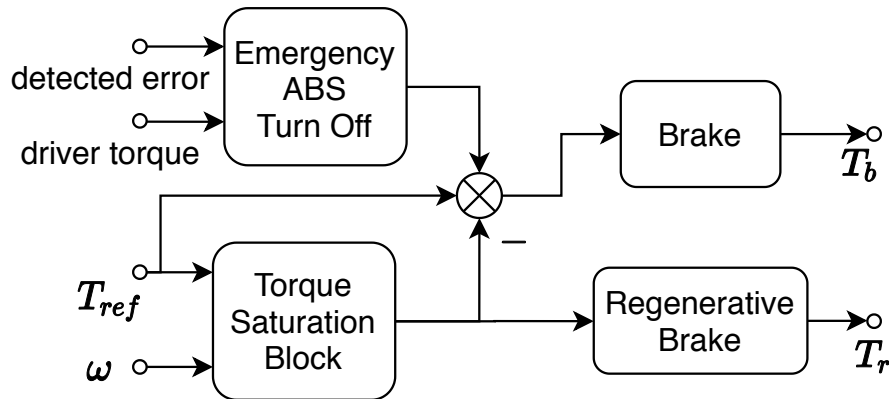

Figure 6.9: Scheme of the braking subsystem for regenerative ABS system.

BrakingSystem. The reference brake torque determined by the closed-loop controller enters this block. In the **TorqueSaturationBlock**, maximal brake torque which can be produced by the regenerative brake system is determined. The regenerative brake torque is limited by minimal and maximal torque and power of the electric motor and by the minimal wheel speed. The difference

between reference brake torque and determined regenerative brake torque is generated by the friction-based brake.

6.2.4 Validation

Test 1 - Reference tracking

In the first test, the reference signal tracking quality is examined. The vehicle is going straightforward and the load force factor k is set to 1 for each wheel. The initial speed of the vehicle is set to 100 km/h, the reference acceleration course is displayed in Figure 6.10. Generated brake and motor torques are displayed in Figure 6.11.

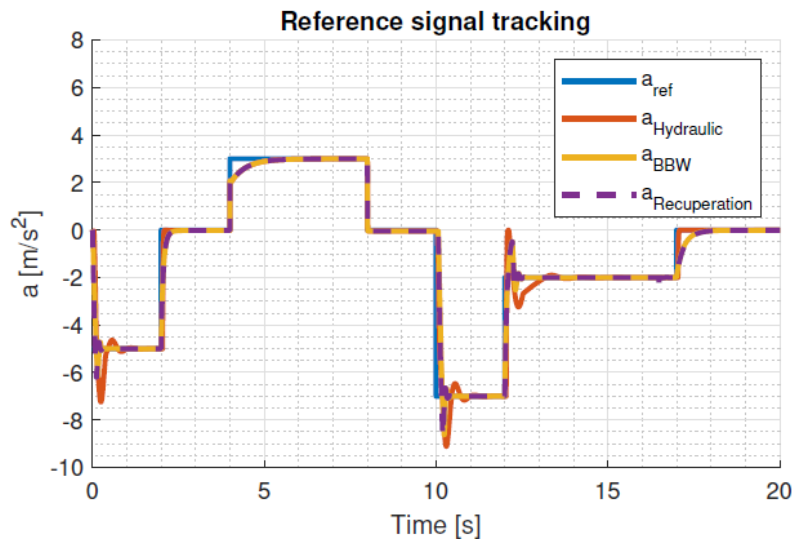

Figure 6.10: The reference acceleration tracking comparison.

In Figures 6.10 and 6.11, it can be seen that the ABS systems with brake-by-wire brakes overshoot less and settle down more quickly than the system with hydraulic brakes. That is not a surprise, because the hydraulic brake system is slower than the brake-by-wire system. In Figure 6.11, the applied brake and motor torques can be seen. The third graph shows that the regenerative brake system is able to generate brake force mainly by the electric motor most of the time. The friction-based brakes are only used in low speeds and when the reference acceleration exceeds -4 m/s^2 . At time $t = 17 \text{ s}$, it can be seen that the motor is turned off, because the wheel speed falls under the minimal speed limit. The generated longitudinal slips for each ABS system can be found in Appendix B in Figure B.5.

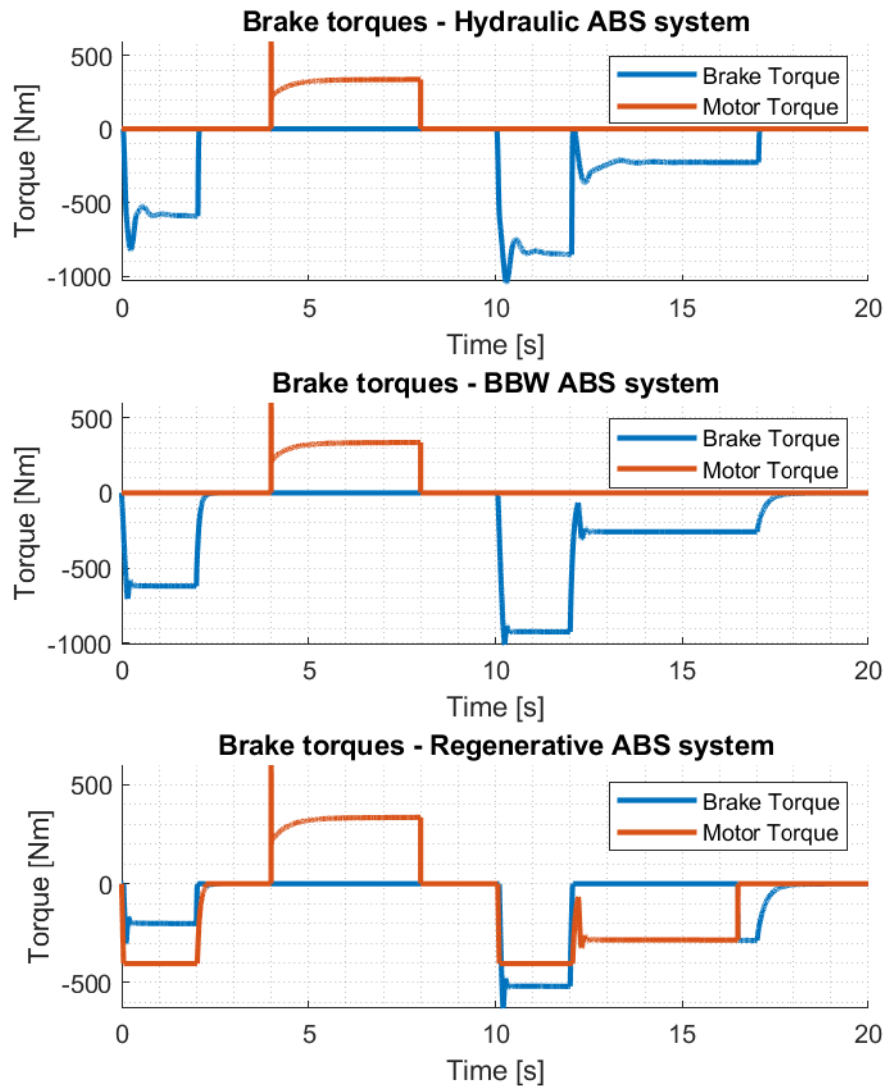

Figure 6.11: The brake torque comparison of the ABS systems.

■ Test 2 - Emergency braking

In this scenario, the emergency braking under adverse road conditions is tested. The vehicle is going straightforward and the initial speed is set to 100 km/h. The reference acceleration is set to -10 m/s^2 , which corresponds to full braking. Two road surface conditions are tested. In the first test, load force factor is set to $k = 0.2$, which simulates a snowy road. In the second test, k is set to 0.4, which simulates a wet road. The total stopping distances with and without the ABS systems are depicted in Figures 6.12 and 6.13.

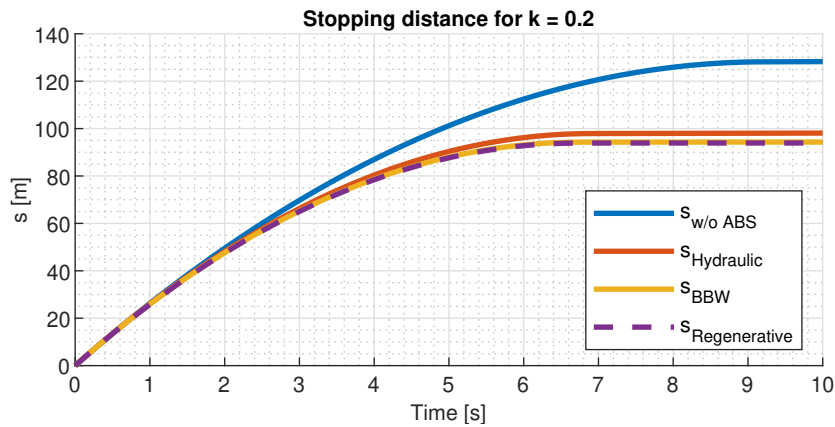

Figure 6.12: Comparison of vehicle stopping distances for $k = 0.2$.

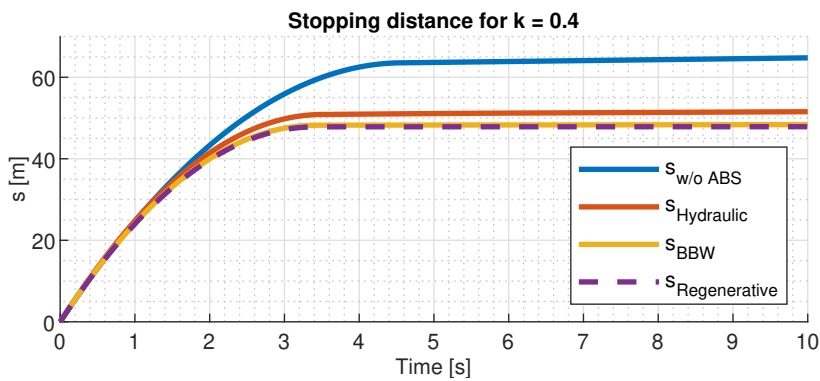

Figure 6.13: Comparison of vehicle stopping distances for $k = 0.4$.

Figures 6.12 and 6.13 show that the stopping distance is slightly shorter for the brake-by-wire ABS systems. However, all designed ABS systems reduce the stopping distance significantly compared to the brake systems without the ABS functionality. More graphs containing the brake torques, longitudinal slips and wheel speeds can be found in the Appendix B in Figures B.6 - B.11.

■ Test 3 - μ -split condition

The third scenario simulates μ -split road conditions. The μ -split means that the friction coefficients under each wheel are different. In this case, the load force factor is set to $k = 0.2$ for the left side of the vehicle and to $k = 1$ for the right side. Different friction coefficients on both sides induces lateral force acting on the vehicle. In this test, it is examined how well the designed ABS system can control brake torque on each wheel to minimize lateral force acting on the vehicle and to ensure lateral stability. The initial vehicle speed is set to 100 km/h and the reference acceleration is set to -10 m/s^2 , which corresponds to emergency braking. The braking lasts for 5 s. The vehicle

is going straightforward. The rotation induced by μ -split condition can be seen in Figure 6.14. More detailed graphs containing generated brake torques, longitudinal wheel slips and wheel speeds for each designed ABS system can be found in Appendix B in Figures B.12 - B.14. In Figure 6.14, it can be seen that the rotation of the vehicle around z -axis is under 3° for all ABS systems, which is an excellent result.

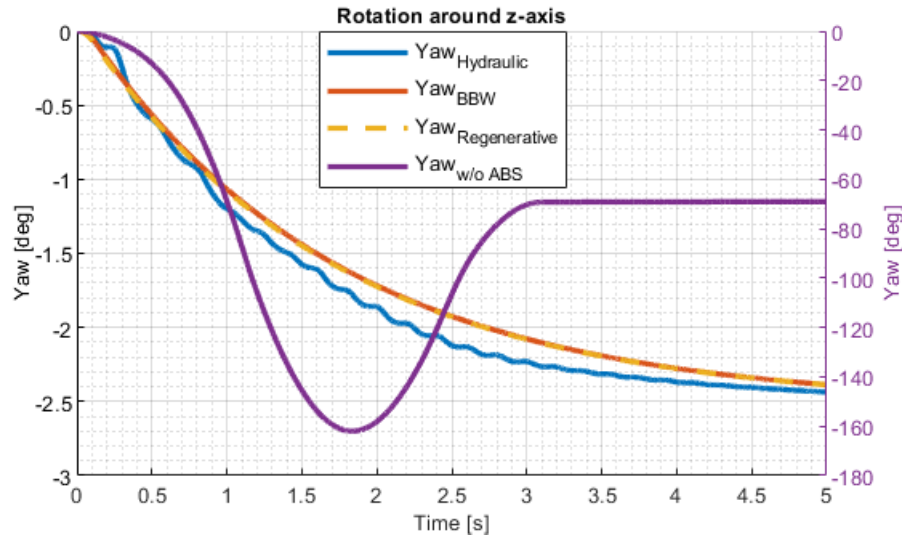

Figure 6.14: Rotation around z -axis induced by μ -split condition.

■ Tests summary

All performed tests show that all implemented ABS systems fulfill all requirements of the ABS system design. All implemented ABS systems significantly reduce stopping distance and preserve steerability under various road and brake conditions. All of them offer an excellent lateral stability control under various μ -split conditions, while going straightforward, therefore they can be used without any additional stabilization system. In all tests, the brake-by-wire ABS systems achieved slightly better results than the hydraulic ABS system. Finally, performed tests show that the regenerative brake system can significantly reduce usage of the friction-based brakes, which leads to reduction of the braking emissions and prolong service-life of the brake system.

■ 6.3 Regenerative ABS system based on Simscape models

This system is a high fidelity version of the regenerative brake-by-wire ABS system implemented above. The design of both systems is the same, only the transfer functions, which represent the regenerative brake subsystem and

the brake-by-wire brake subsystem, are replaced by the Simscape models, which are derived in Chapter 4 (see Figures 4.4 and 4.6). The usage of the Simscape models offers more realistic simulation results, however, the memory demands and simulation time are rapidly increased, therefore this system is only suitable for validation not for the system design purposes.

6.3.1 Validation

To compare both of the designed regenerative ABS systems, the same tests as in the previous section are performed.

Test 1 - Reference tracking

In the first test, the reference signal tracking quality is examined. The results are captured in Figures 6.15 and 6.16.

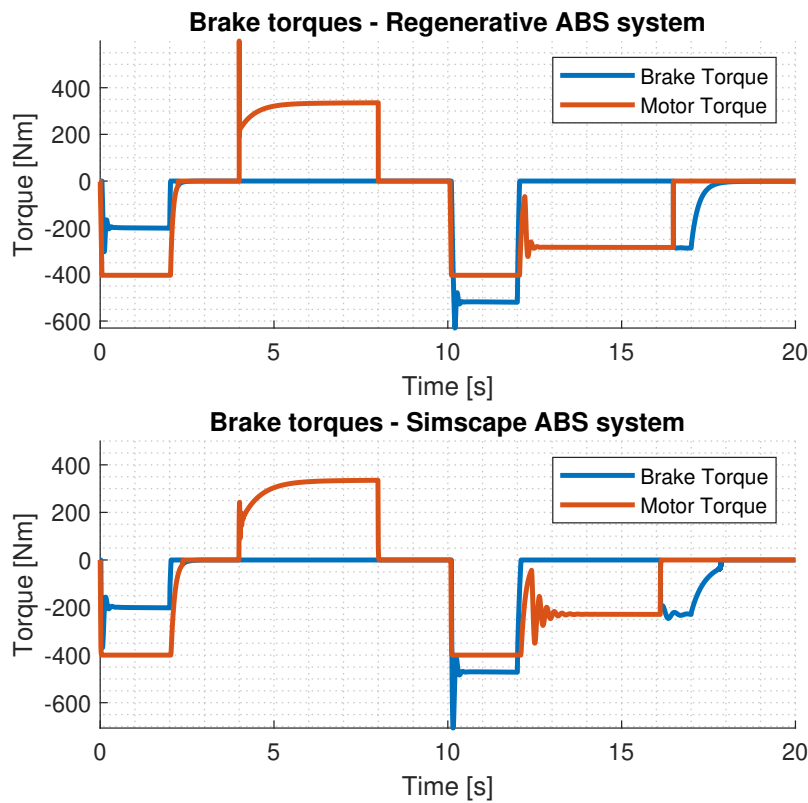

Figure 6.15: The brake and motor torque comparison.

Figure 6.16 shows that the Simscape ABS system overshoots more and settles down for a longer time. The generated longitudinal slips for Simscape

model can be found in Appendix B in Figure B.15.

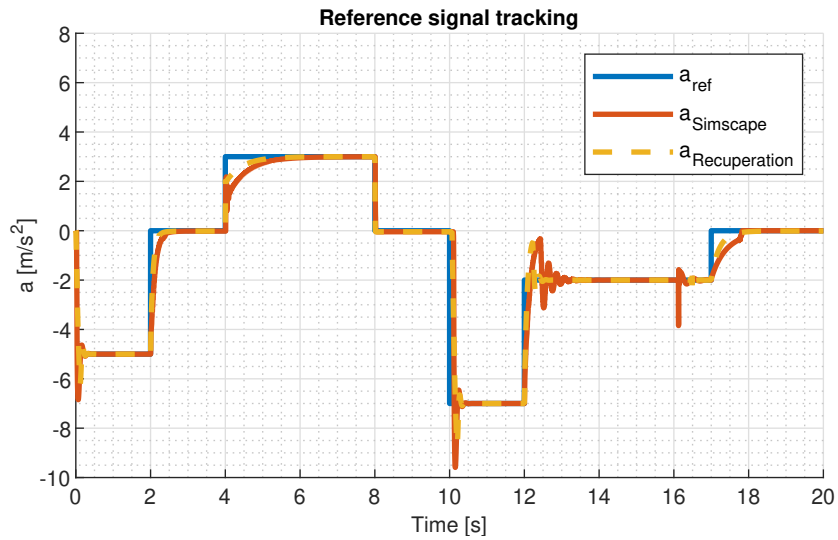

Figure 6.16: The reference acceleration tracking.

■ Test 2 - Emergency braking

In the second scenario, the emergency braking from 100 km/h is tested. The load force factor is set to 0.4 for all wheels. The test results can be seen in Figure 6.17. More detailed graph showing generated torques, longitudinal slips and wheel speeds for Simscape model are attached in Appendix B in Figure B.16.

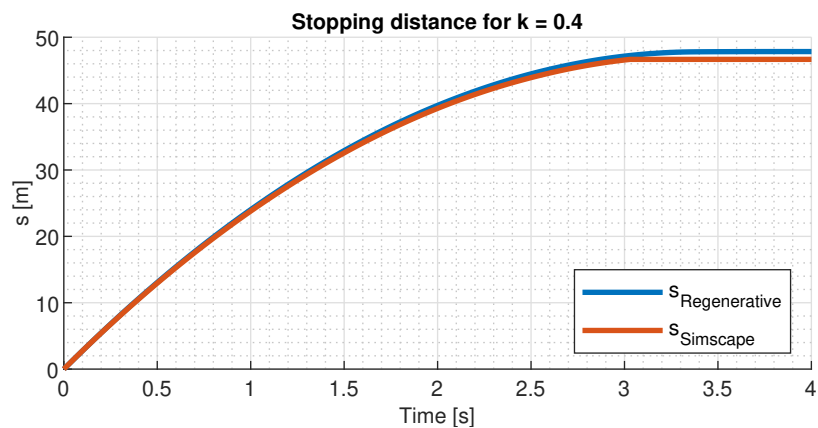

Figure 6.17: The stopping distance of the vehicle for $k = 0.4$.

■ Test 3 - μ -split condition

In the third scenario, μ -split condition is tested. The load force factor is set to 0.2 for the left wheels and to 1 for the right wheels. The initial speed is set to 100 km/h. The rotation around the z -axis is depicted in Figure 6.18. Again, more detailed graphs can be seen in Appendix B in Figure B.17.

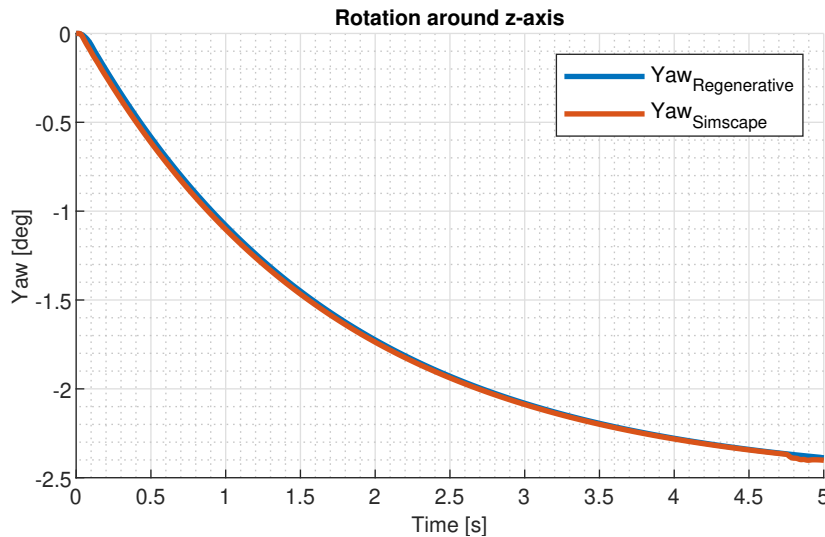

Figure 6.18: Rotation around z -axis induced by μ -split condition.

■ Test 4 - Wheel speed sensor error

In the last test, sensor failures are simulated. Because the Simscape model of the electrical motor allows measurement of the motor angular speed, more sophisticated wheel speed sensor safety control can be implemented. Together with wheel speed sensors and vehicle body speed sensor, three independent measurements of the angular wheel speed can be used. This means that the ABS system can work properly even when a failure in one of the sensors occurs, which makes the whole system more robust. The behaviour of the implemented safety system is captured in Figure 6.19.

Figure 6.19 shows that the ABS system is able to work even when the failure of one speed sensor occurs. At time $t = 6$ s, it can be seen that the failure of both sensors is detected, the ABS system is switched off and the driver gains direct control over generated brake torques (for safety reasons, the driver can directly control only the brakes).

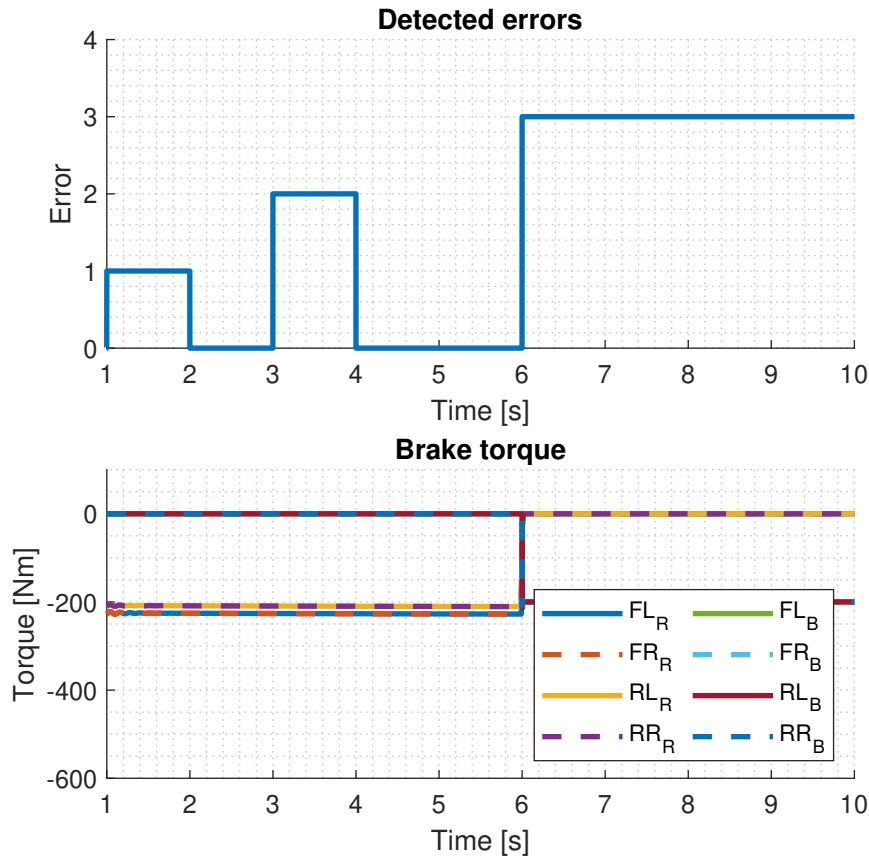

Figure 6.19: The top graph represents detected wheel speed failures. Error meanings: 0 represents no error, 1 represents the motor speed sensor error, 2 represents the wheel speed error, 3 represents error of both sensors.

■ Tests summary

The designed drive-by-wire control strategy achieved slightly worse but still quite good results on the Simscape model based high fidelity system. The high fidelity system overshoots more and it settles down for a longer time. In Figure B.16 in Appendix B it can be seen at time 2.5s that the Simscape system starts to oscillate a bit. At the same, the electric motor is switched off and the friction-based brake has to generate even more brake torque in order to compensate for the lost torque generated by the electric motor. The oscillation is not caused by the designed drive-by-wire architecture of the system, but it is caused by the poor implementation of the Simscape brake-by-wire block. The torque controlled electric motor used in the Simscape brake-by-wire block has the tendency to overshoot, which leads to oscillation. This issue can be solved by implementing a better motor control approach, the motor position control will probably suit the requirements the best.

Chapter 7

Brake-by-steer system design

In this chapter, design of the proposed brake-by-steer system will be described. As discussed in Chapter 3, the brake-by-steer concept will be used only as an emergency backup brake system.

7.1 System design

The block scheme of the proposed brake-by-steer system can be seen in Figure 7.1.

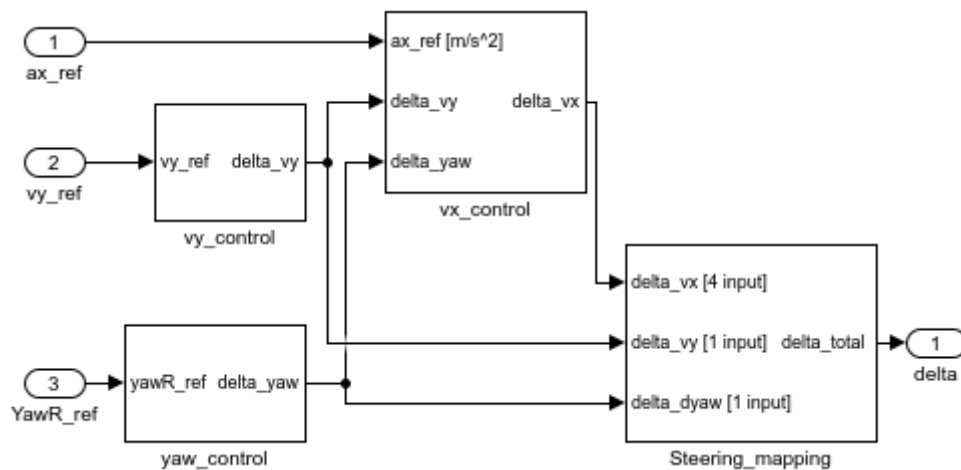

Figure 7.1: Block scheme of the designed brake-by-steer system.

The system consists of four blocks described below. The inputs of the system are reference vehicle acceleration in x -axis and y -axis and reference yaw rate. The output of the system is the steering angle for each wheel. The maximal steering angle is limited to 60° , the maximal steering angle available for braking is limited to 35° .

SteeringMapping. The function of this block is to map the input steering angles to obtain desired wheel steering configuration. Three configurations are available: snow plow position (denoted as δ_{vx}), turning the vehicle around the vehicle center (denoted as δ_{yaw_rate}) and turning the vehicle in y -direction (denoted as δ_{vy}). Figure 7.2 illustrates all configurations. The inputs of this block are steering angles for each configuration. All the input steering angles are appropriately mapped and summed up. The outputs of the system are total steering angles for all wheels. The dynamics of the steering system is modeled by the first order transfer function block. Note that the inputs δ_{yaw_rate} and δ_{vy} are scalars, therefore all wheels are steered by the same angle according to selected mapping. The δ_{vx} input is a 1x4 vector, therefore steering angle of each wheel can be controlled independently according to the snow plow mapping.

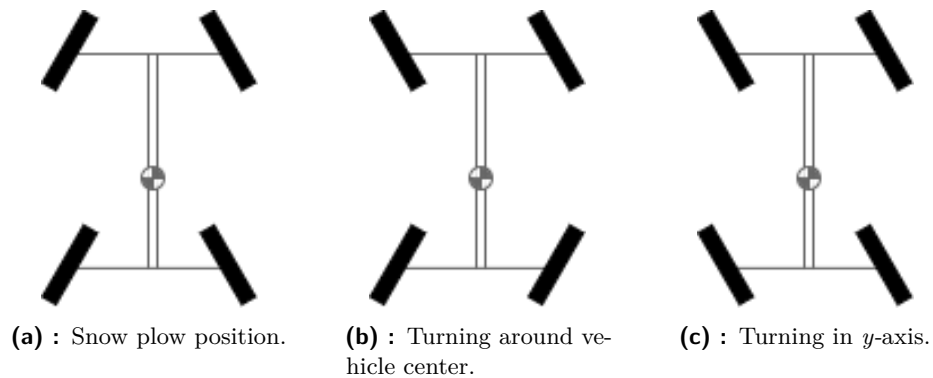

Figure 7.2: Possible steering configurations.

v_x _control. The function of this block is to decelerate the vehicle. The inputs of this block are reference vehicle acceleration and reference yaw rate. The system consists of one closed-loop formed by four PI controllers, which regulate steering angles on each wheel. The controllers take the error between reference vehicle acceleration and actual acceleration in wheel mounting center for each wheel as an input. To transform vehicle body acceleration to the wheel mounting center, the $\mathbf{B} \rightarrow \mathbf{W}$ block introduced in Chapter 6 is used. The output of the system is the steering angle for each wheel.

yaw_control. The function of this block is to compensate the lateral forces, which are induced by the rotation around the z -axis. The block consists of one controller of the type PI, which regulates the δ_{yaw_rate} .

v_y _control. This block is also used for the lateral stability control. This block compensates the lateral force induced by forces acting on the vehicle body in y -direction. The block is formed by the closed loop PI controller, which regulates δ_{vy} .

7.2 Validation

7.2.1 Test 1 - Reference tracking

In the first test, the reference input signal tracking quality is examined. The vehicle is going straightforward on a dry road, the load force factor is set to 1. The initial speed of the vehicle is set to 100 km/h.

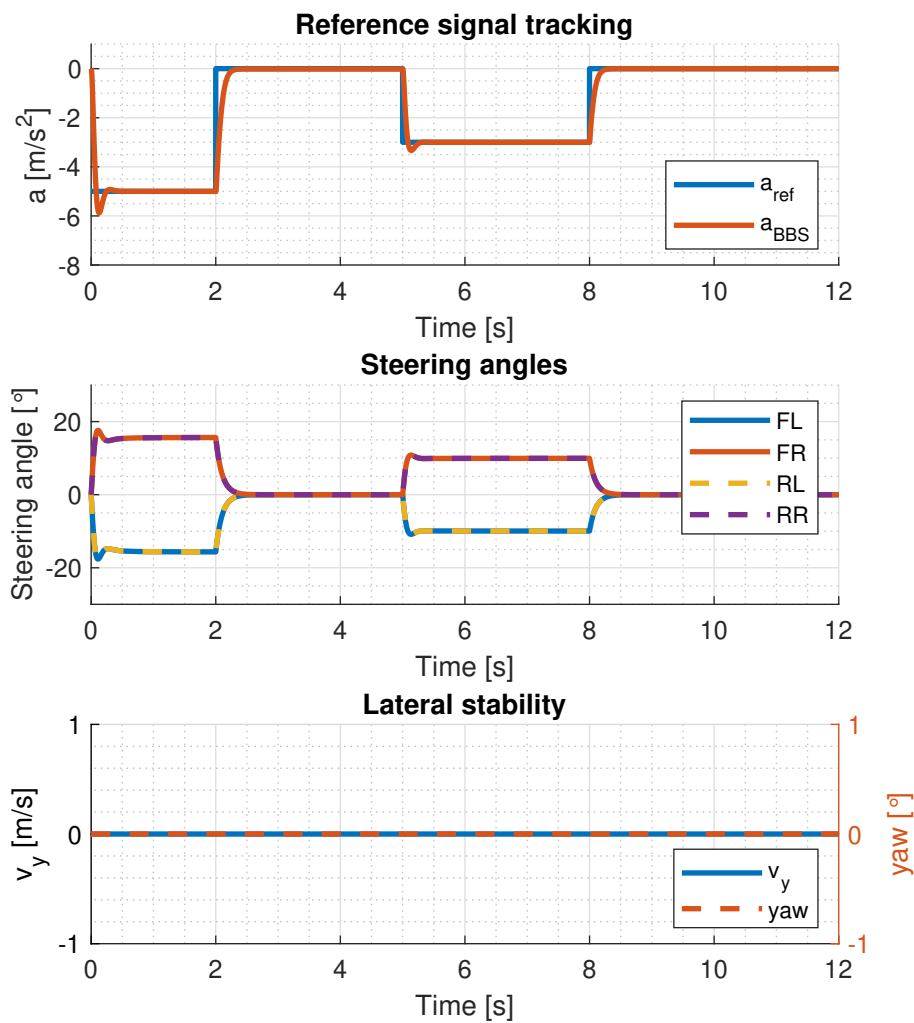

Figure 7.3: Reference signal tracking and vehicle lateral stability.

In Figure 7.3, signal tracking, steering angles and lateral stability are depicted. Figure 7.4 shows forces acting on all wheels. The figures demonstrate

that the designed system follows the input reference quite well and that no lateral force acting on the vehicle body is induced, therefore vehicle stability is ensured.

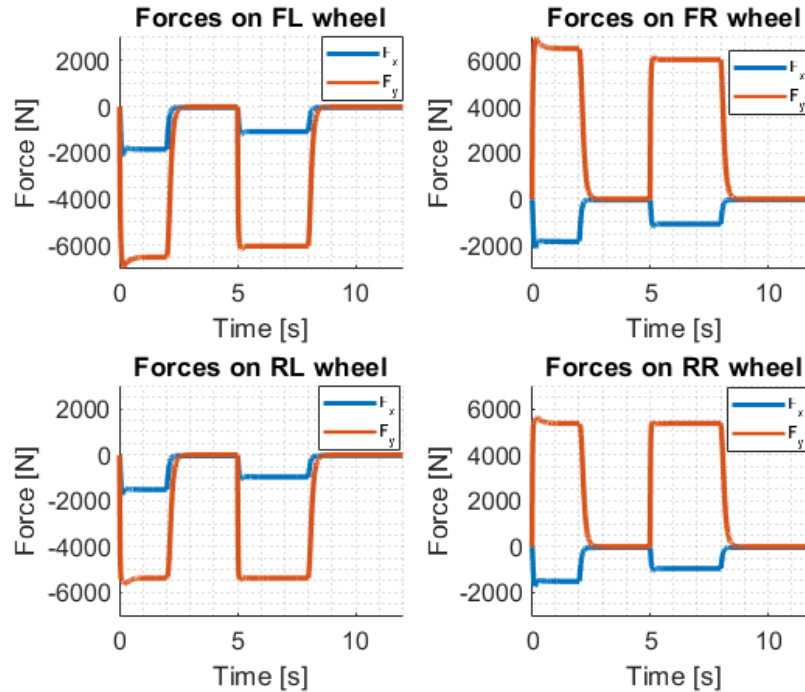

Figure 7.4: Forces on the wheels induced by steering. The blue line represents force in x -axis, the red line represents force in y -axis in wheel coordinate system.

7.2.2 Test 2 - Emergency braking

In the second scenario, emergency braking is tested. The emergency braking is tested for two surfaces. The first one simulates a dry road, therefore the load force factor is set to 1. The second one simulates adverse road conditions and the load force factor is set to 0.2. The vehicle is going straightforward, the initial vehicle speed is 100 km/h and the reference acceleration is set to -10 m/s^2 , which corresponds to full braking. The emergency braking is performed for two seconds.

The Figure 7.5 shows that the generated steering angles are the same for both surfaces. At first sight, it can look like the brake performance is the same on both surfaces. However, it has to be considered that the generated brake force is dependent not only on the steering angles but also on the load force, therefore the same steering angles do not generate the same brake force on different surfaces. The generated forces are depicted in Figure 7.6 and 7.7. The vehicle speeds are depicted in Figure 7.9. Finally, Figure 7.8 shows that no lateral forces acting on the vehicle body are induced by the braking.

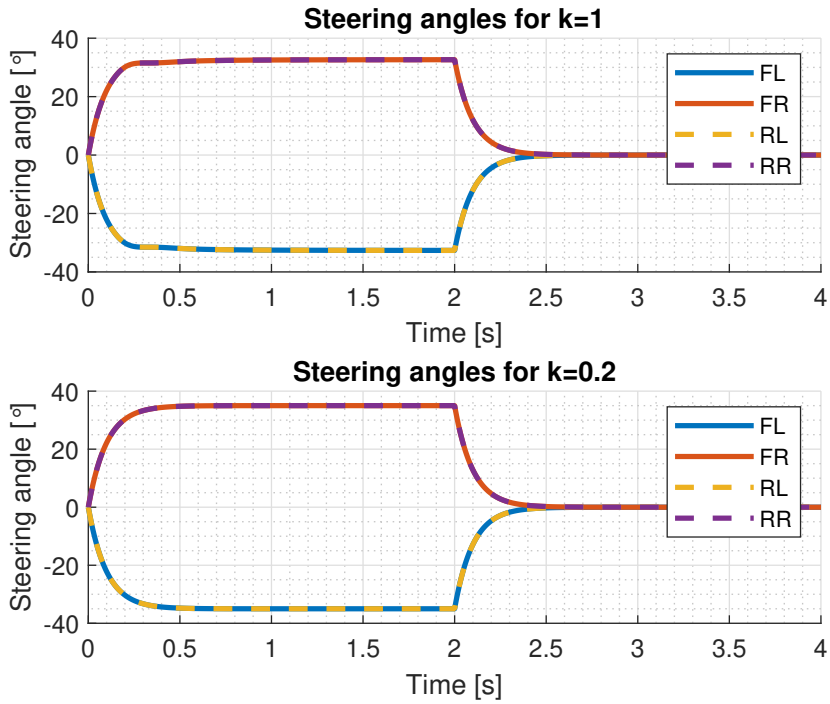
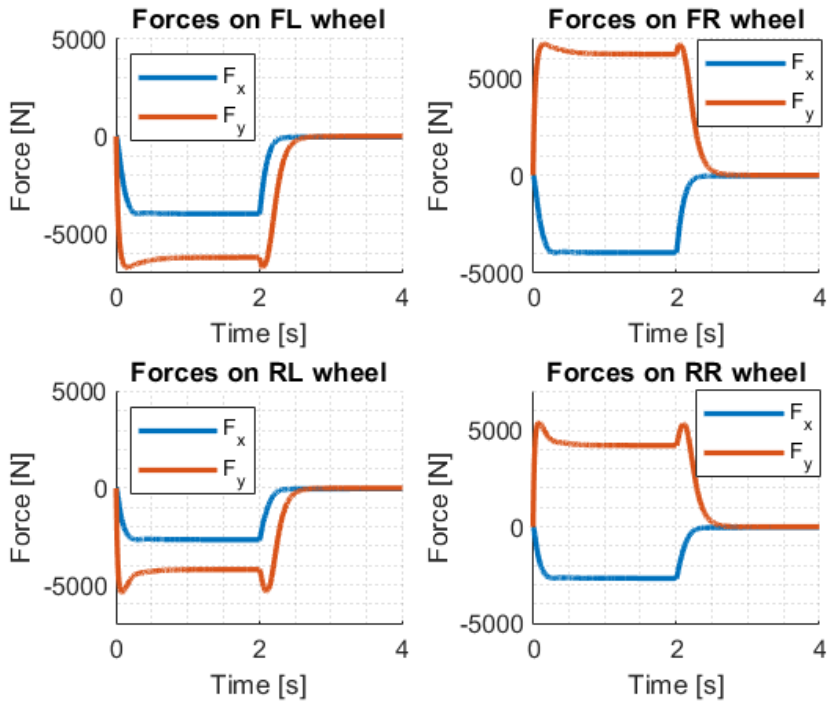

Figure 7.5: Generated steering angles.

Figure 7.6: Generated forces on the wheels for $k = 1$. The blue line represents force in x -axis, the red line represents force in y -axis in wheel coordinate system.

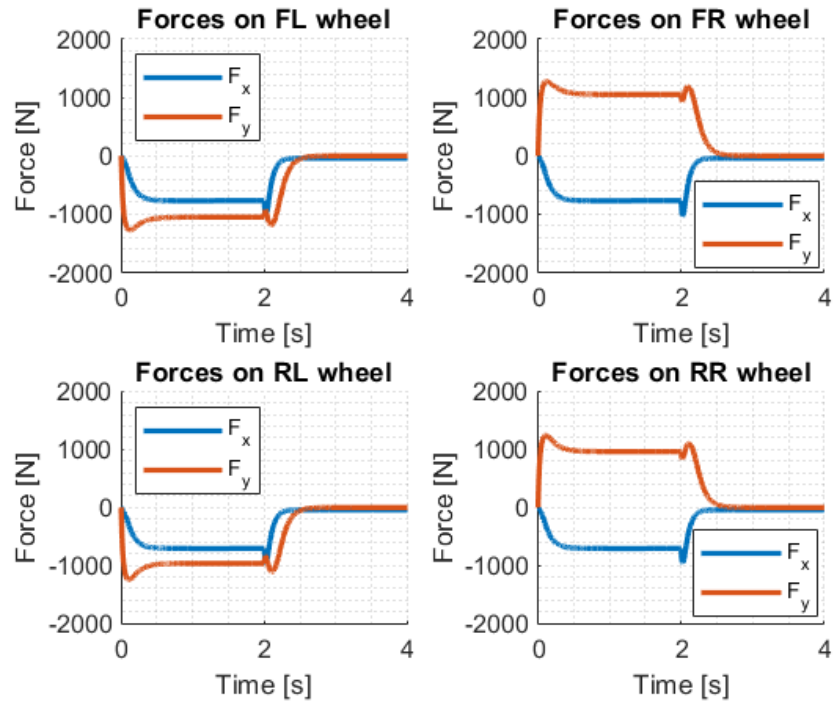

Figure 7.7: Generated forces on the wheels for $k = 0.2$. The blue line represents force in x -axis, the red line represents force in y -axis in wheel coordinate system..

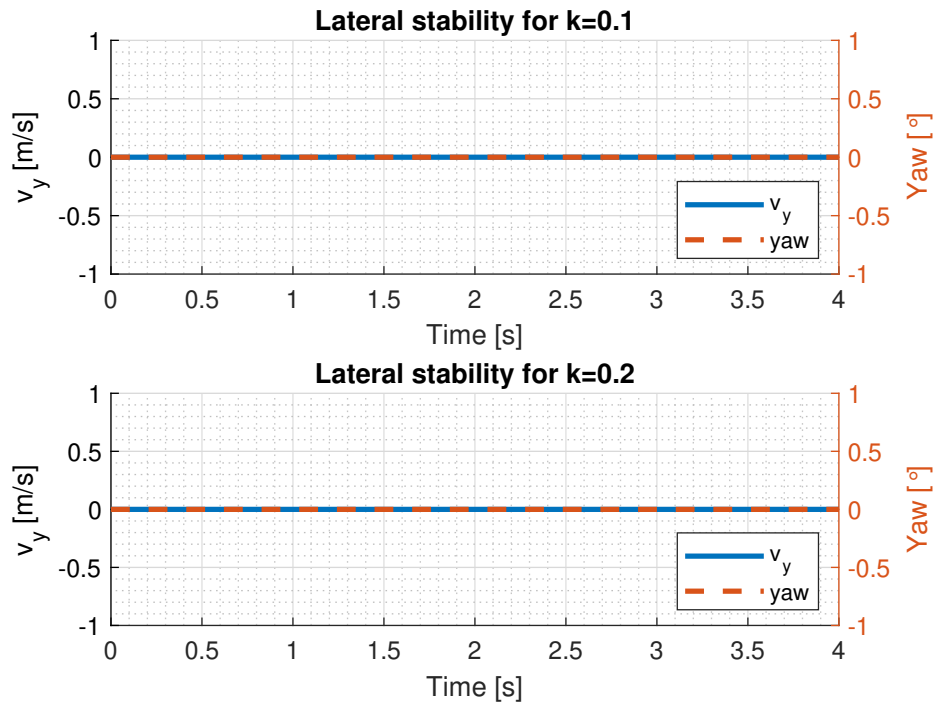

Figure 7.8: Vehicle lateral speed and yaw angle.

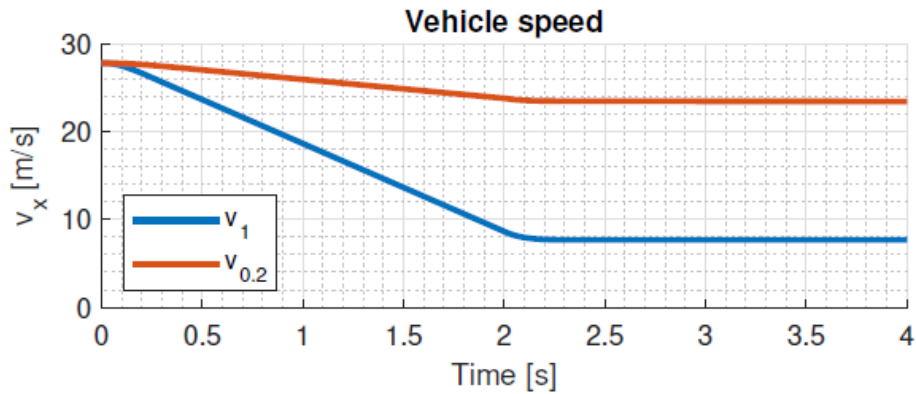

Figure 7.9: Vehicle speed.

7.2.3 Test 3 - μ -split condition

In the third test scenario, the lateral stability of the vehicle under the μ -split conditions is tested. Two tests are performed. In the first one, the load force factor is set to 0.2 for the left side and to 1 for the right side. In the second test, the load force factor is set to 0.8 for the left side and to 1 for the right side. The reference acceleration is set to -10 m/s^2 for three seconds. In Figure 7.10, steering angles for both scenarios are displayed.

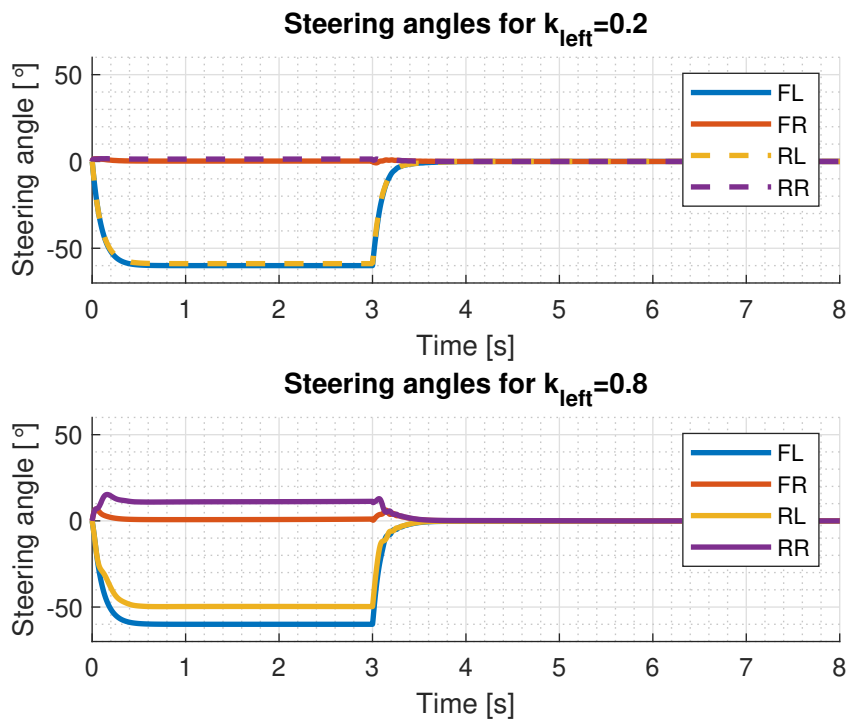

Figure 7.10: Generated steering angles in both tests.

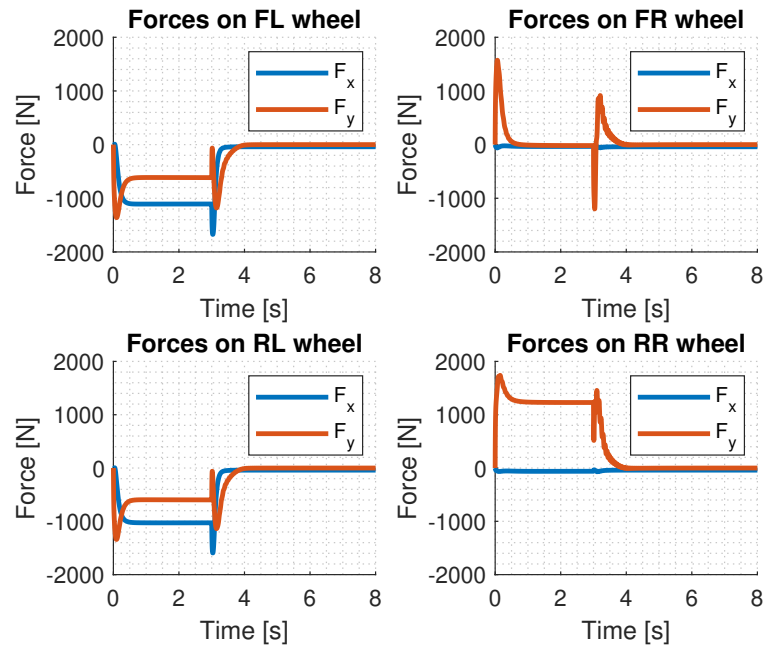

Figure 7.11: Generated forces on the wheels for $k = 0.2$ on the left side. The blue line represents force in x -axis, the red line represents force in y -axis in wheel coordinate system.

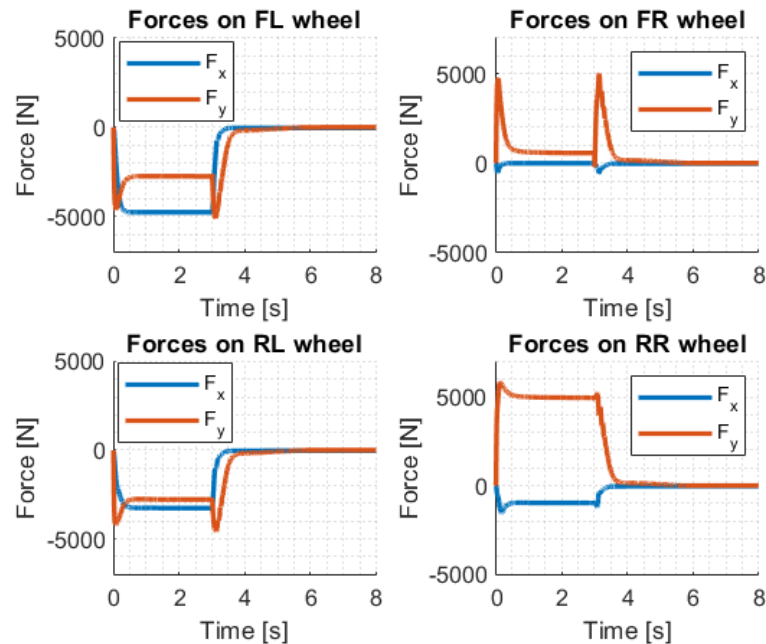

Figure 7.12: Generated forces on the wheels for $k = 0.8$ on the left side. The blue line represents force in x -axis, the red line represents force in y -axis in wheel coordinate system.

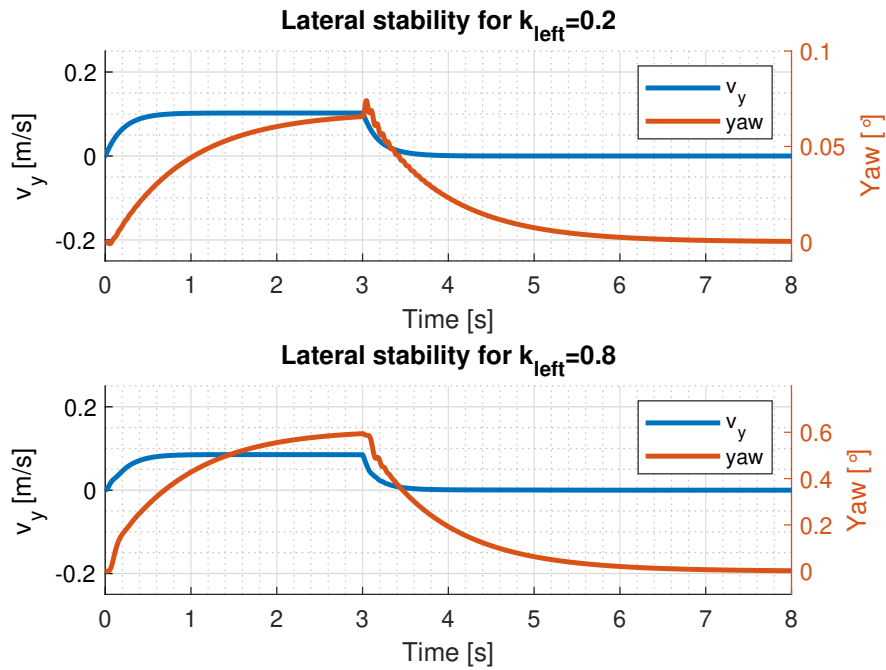

Figure 7.13: Vehicle lateral speed and yaw angle.

Figure 7.13 shows that the vehicle lateral stability control is excellent in both scenarios. An interesting fact is that the generated yaw angle is smaller for the scenario with $k = 0.2$ on the left side. The reason for that is that in this scenario, generated forces are smaller, therefore it is easier to maintain the lateral stability for the controller.

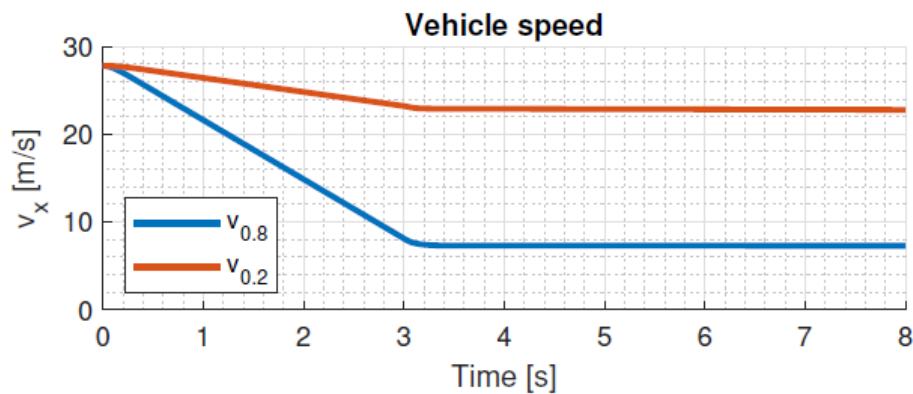

Figure 7.14: Vehicle speed.

All performed tests show that the designed brake-by-steer brake system satisfies all requirements for the backup brake system. The driver can control the vehicle deceleration in range 0 m/s^2 to -10 m/s^2 , the brake-by-steer works

under various road conditions and maintains great lateral stability. All tests prove that the brake-by-steer concept can be used as a full-fledged brake system, when a fatal failure of the main brake system occurs. Also, the tests show that generated lateral forces are great, which confirms the theoretical results, which are predicted in Chapter 3.



Chapter 8

Conclusion & future work

In this thesis, several brake system control strategies were discussed. The existing twin-track vehicle model was adopted and modified for purposes of the brake system design and verification. Two principal brake systems were considered to demonstrate brake system capabilities. Firstly, the conventional hydraulic brake system was developed, providing state-of-the-art brake platform. Secondly, the brake-by-wire model was implemented to study the capabilities of future brake means. Simplified models were introduced for both hydraulic based and brake-by-wire based brake systems.

Two control strategies were then developed for each brake system. First of all the ABS functionality was introduced to represent the conventional ABS approach. Then the drive-by-wire control system with direct wheel speed control was implemented as a representation of the systematic approach to vehicle traction control, where the ABS functionality is an inherent part. Finally, the series of tests were performed to compare the brake systems. Tests showed that the drive-by-wire approach achieves better results in comparison to the conventional ABS implementation, which is mostly caused by the absence of the hydraulic delay.

To further validate the designed drive-by-wire control system, high fidelity brake system virtual model based on the Simscape components was used. Designed drive-by-wire control strategy achieved slightly worse but still great results in all tests performed on the Simscape models.

Finally, the innovative brake-by-steer concept was implemented in the last chapter. The designed system has no ambition to work as a primary brake system in a vehicle. The brake-by-steer approach is intended as a backup system for the friction based brake systems, namely the brake-by-wire. All performed tests showed great results, therefore the developed brake-by-steer system can be used to satisfy the safety requirements which the brake-by-wire system does not fulfill.

■ 8.1 Future work

Finally, the ideas which can be used as future improvements are listed below.

- To implement more realistic brake-by-wire system, mainly to develop better controller for used electric motor in the brake-by-wire system
- To use more sophisticated control design strategies than the presented PI controllers, tuned by the Ziegler-Nichols method
- To augment designed regenerative brake system by a battery management system



Appendix A

Bibliography

- [BBS11] Tarun Bera, K. Bhattacharya, and Arun Samantaray, *Evaluation of antilock braking system with an integrated model of full vehicle system dynamics*, *Simulation Modelling Practice and Theory* **19** (2011), 2131–2150.
- [Cib19] Vít Cibulka, *MPC based control algorithms for vehicle control*, Master thesis, Czech Technical University, Prague, 2019.
- [Gmb14] Robert Bosch GmbH, *Bosch automotive handbook*, 9th edition ed., Wiley, Germany, 2014.
- [Jan10] B. Jansen, *Brake-by-steer concept*, Master thesis, Delft University of Technology, Delft, 2010.
- [Lib16] Max Liben, *Wr-217 architecture design*, 2016, [Online], Accessed: 2020-04-21, <https://static1.squarespace.com/static/57e8888fc534a547699d733d/t/59705bcf893fc0cc2911099a/1500535765921/WR-217e+Architecture+Design>.
- [Lou17] Malcolm Loughead, *Braking apparatus*, 1917.
- [MAT19] MATLAB, *version 9.7.0.1247435 (r2019b) update 2*, The MathWorks Inc., Natick, Massachusetts, 2019.
- [MK14] Ahmed Mohamed Mostafa-Kamal, *Control of an electro-mechanical brake-by-wire system using sliding mode control*, 2014.
- [Pac12] Hans B. Pacejka, *Tire and vehicle dynamics*, 3rd edition ed., Elsevier Ltd., Oxford, 2012.
- [SHB14] Dieter Schramm, Manfred Hiller, and Roberto Bardini, *Vehicle dynamics*, 2nd edition ed., Springer, Duisburg, 2014.
- [vHNC14] B.A.P. van Duifhuizen, P.D. Hobo, H. Nijmeijer, and A. Khajepour, *Modeling, design and control of an individual wheel actuated brake*

system, D&C, Eindhoven University of Technology, 2014
(English), Traineeship report. - DC 2014.052.



Appendix B

Figures

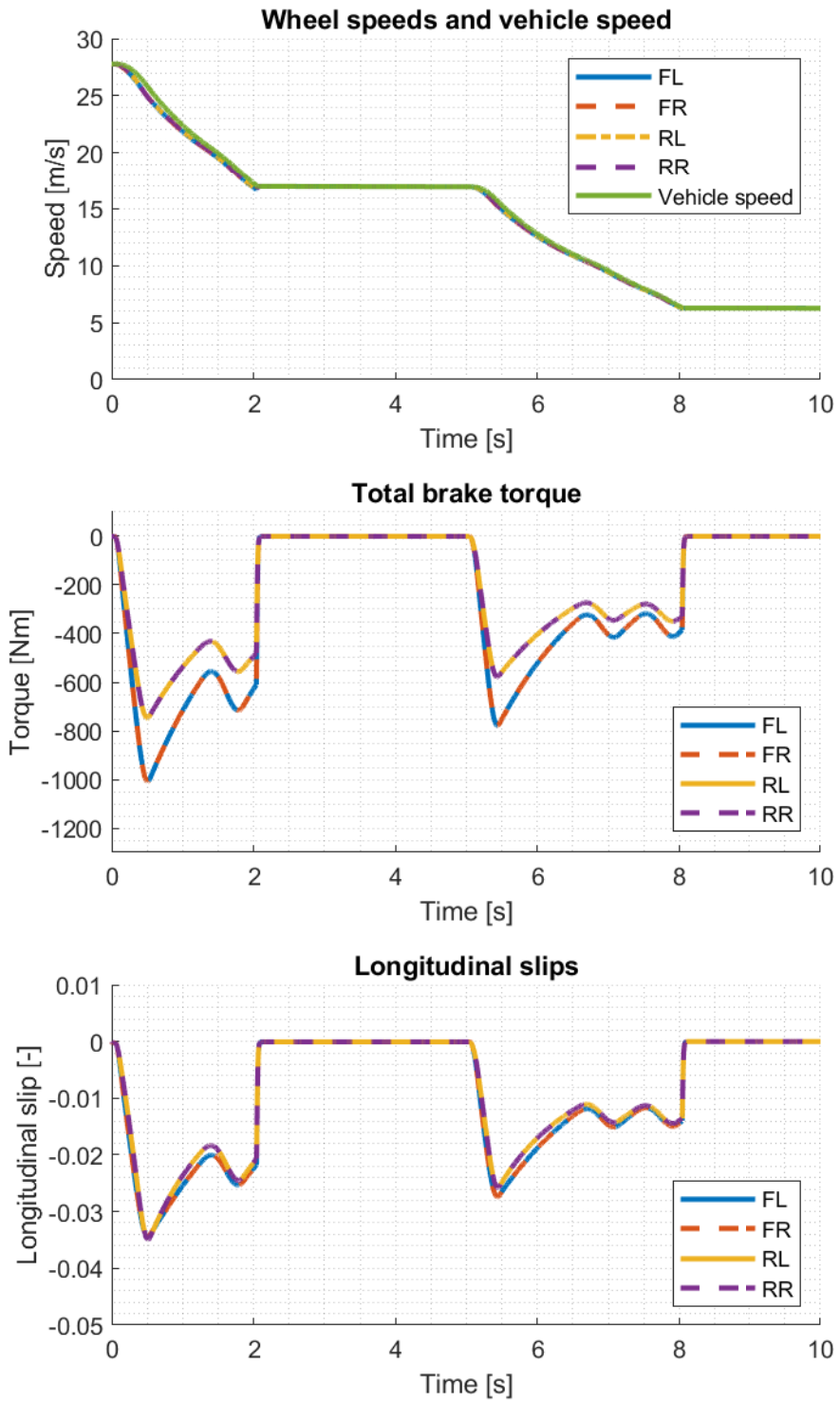

Figure B.1: Test scenario no.1 - input reference tracking. The conventional hydraulic ABS system.

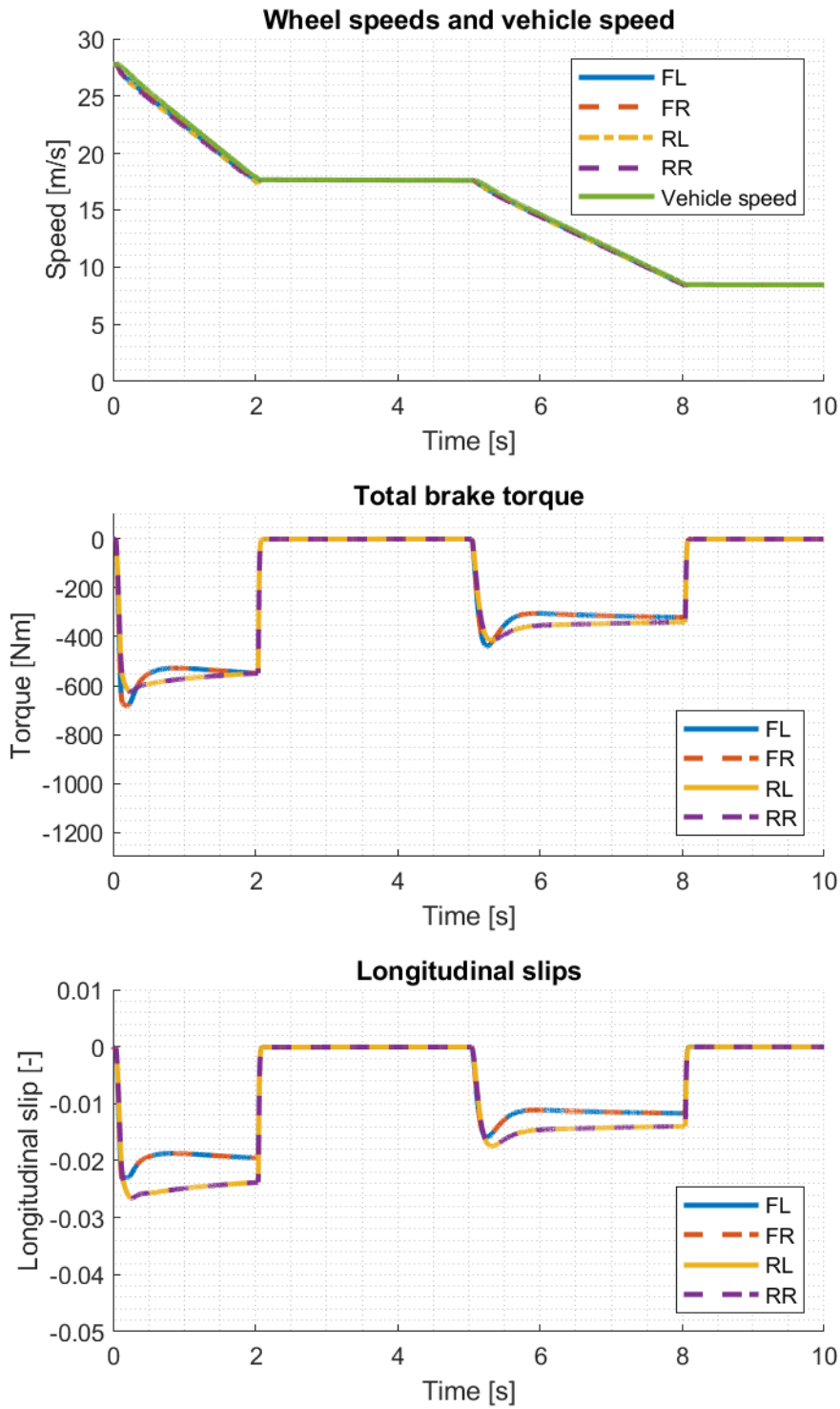

Figure B.2: Test scenario no.1 - input reference tracking. The hydraulic based ABS system with the drive-by-wire approach.

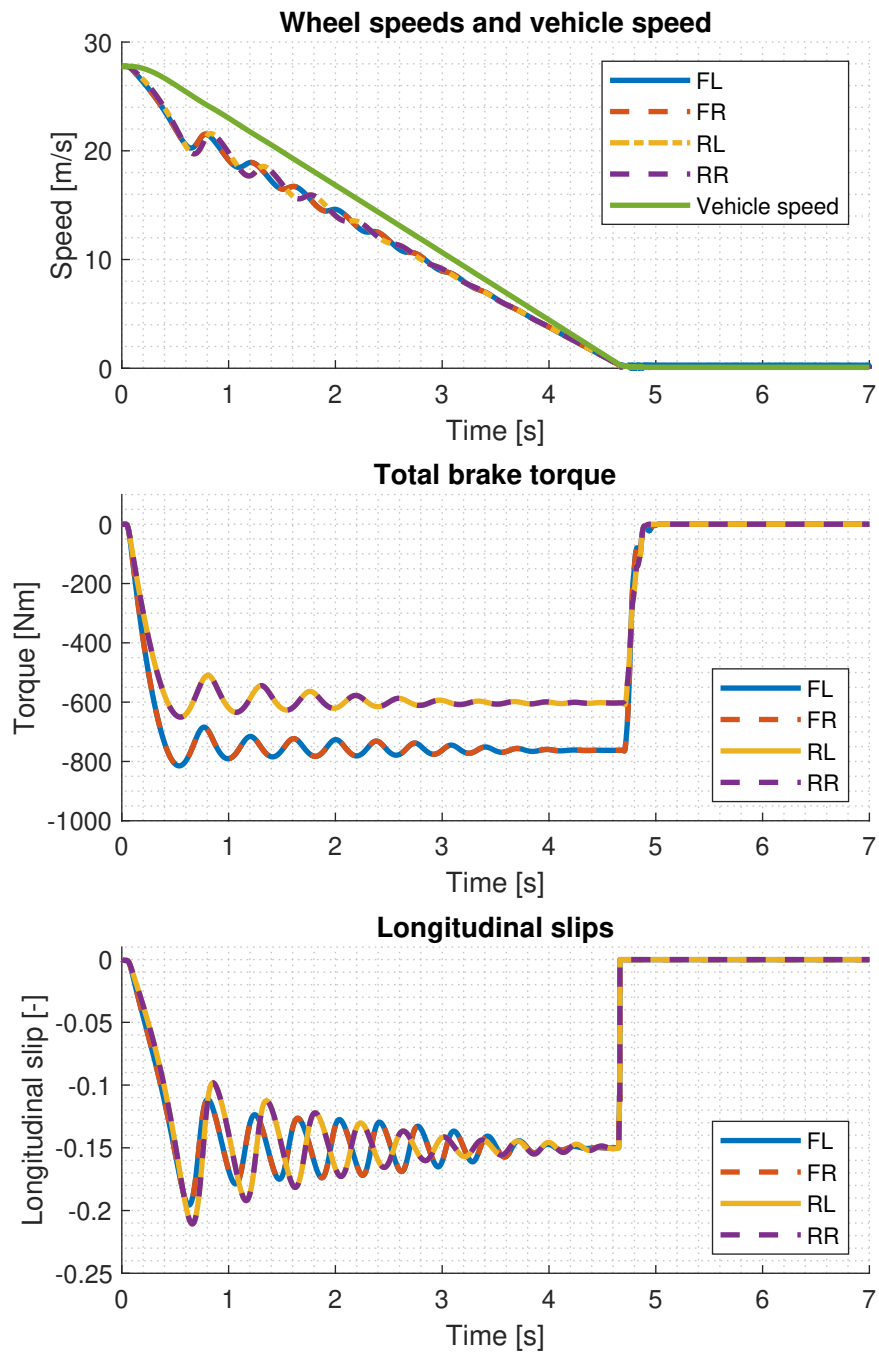

Figure B.3: Test scenario no.2 - emergency braking under adverse road conditions. The conventional hydraulic ABS system.

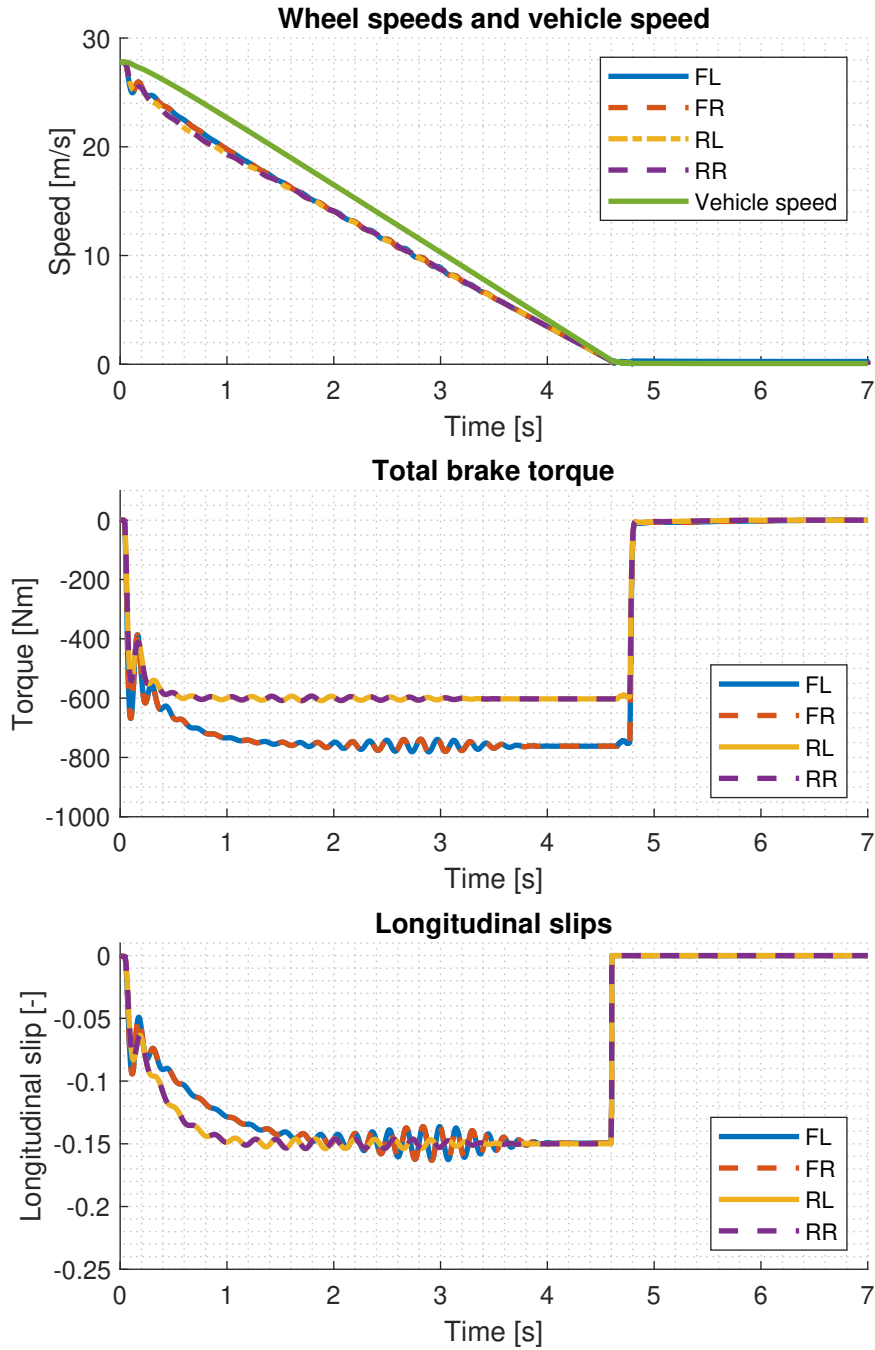

Figure B.4: Test scenario no.2 - emergency braking under adverse road conditions. The hydraulic based ABS system with the drive-by-wire approach.

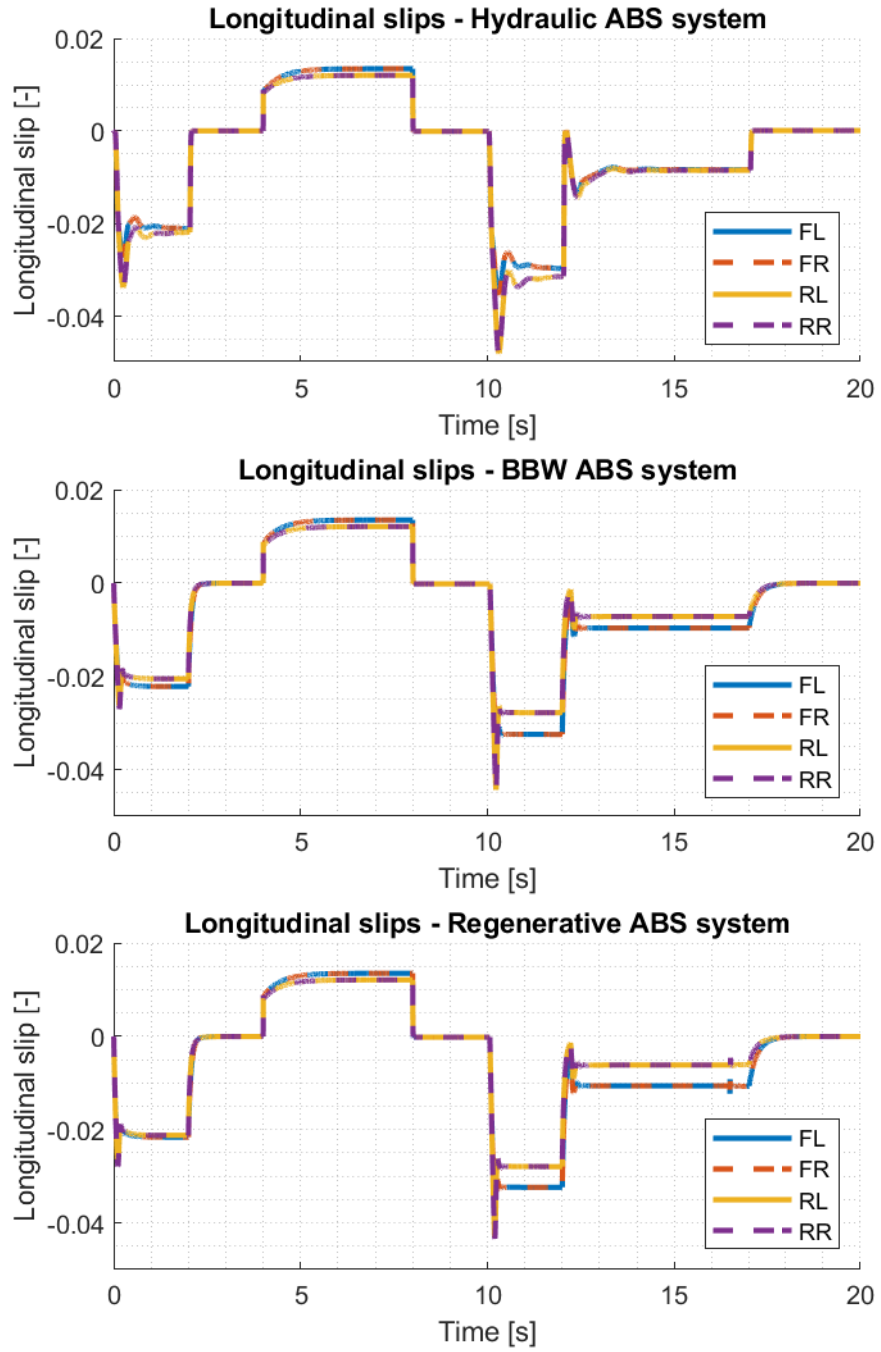

Figure B.5: Test scenario no.1 - input reference tracking. Generated longitudinal slips.

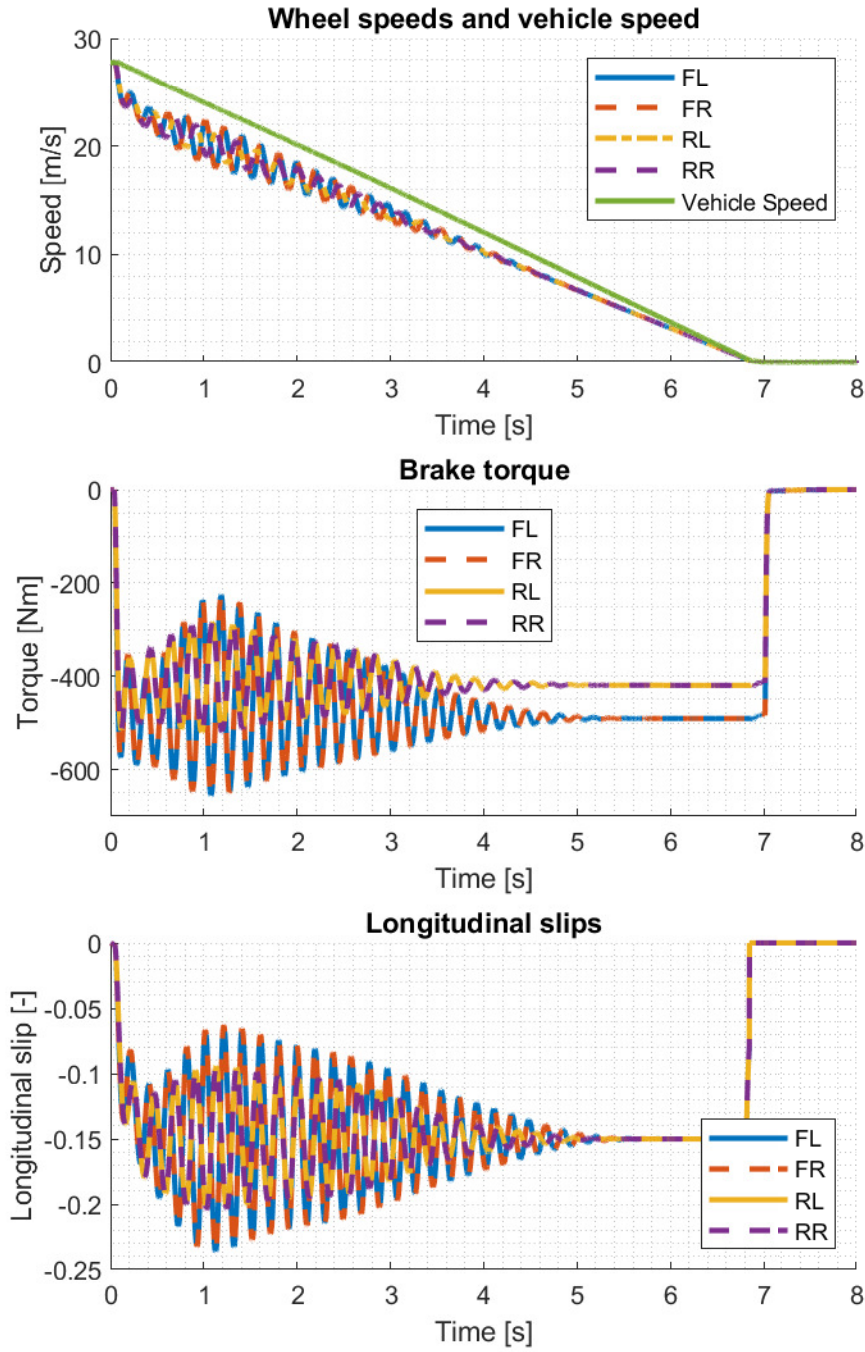

Figure B.6: Test scenario no.2 - emergency braking for $k = 0.2$ using hydraulic ABS. Generated brake torques, wheel speeds and longitudinal slips.

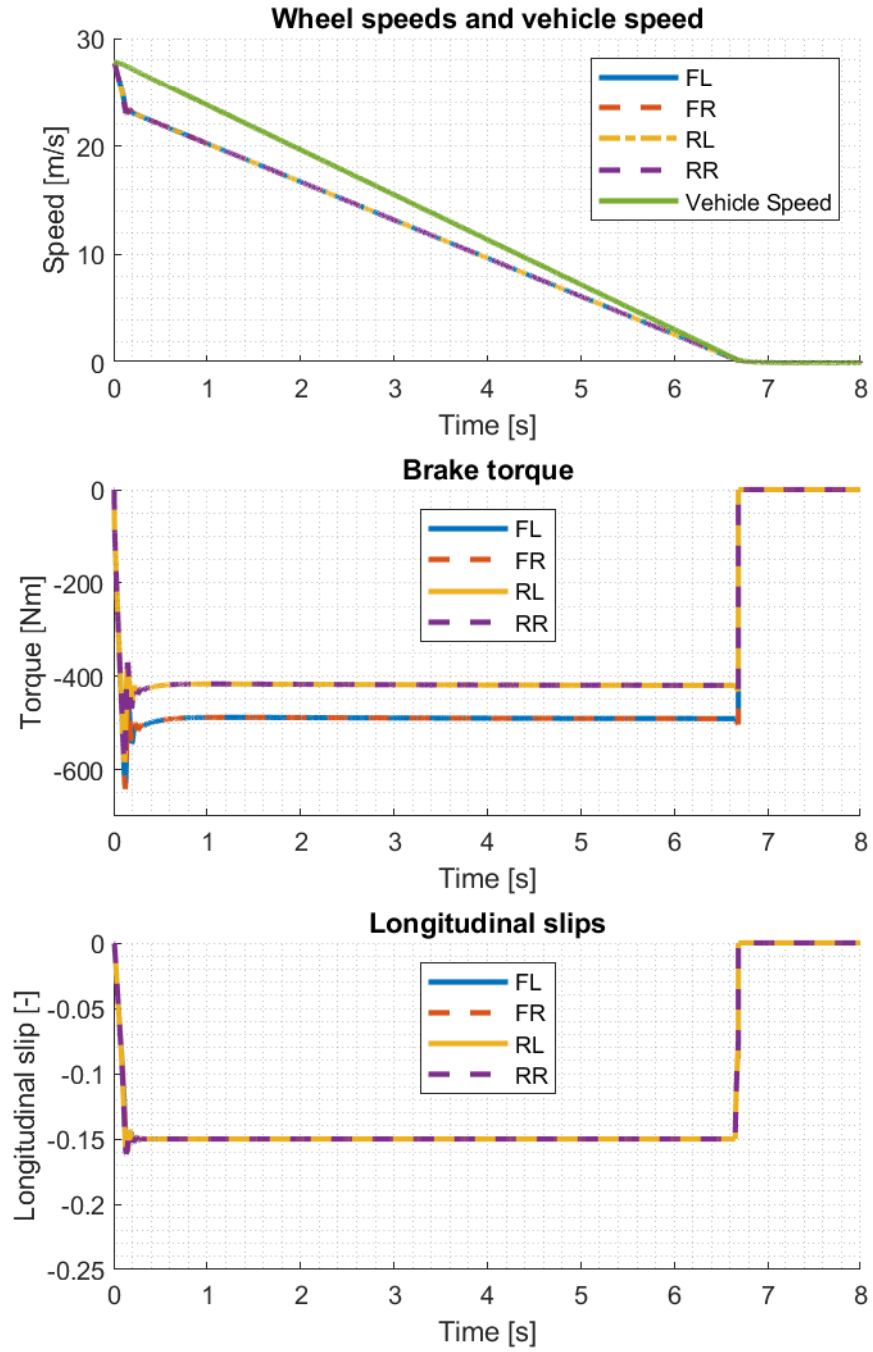

Figure B.7: Test scenario no.2 - emergency braking for $k = 0.2$ using brake by wire ABS. Generated brake torques, wheel speeds and longitudinal slips.

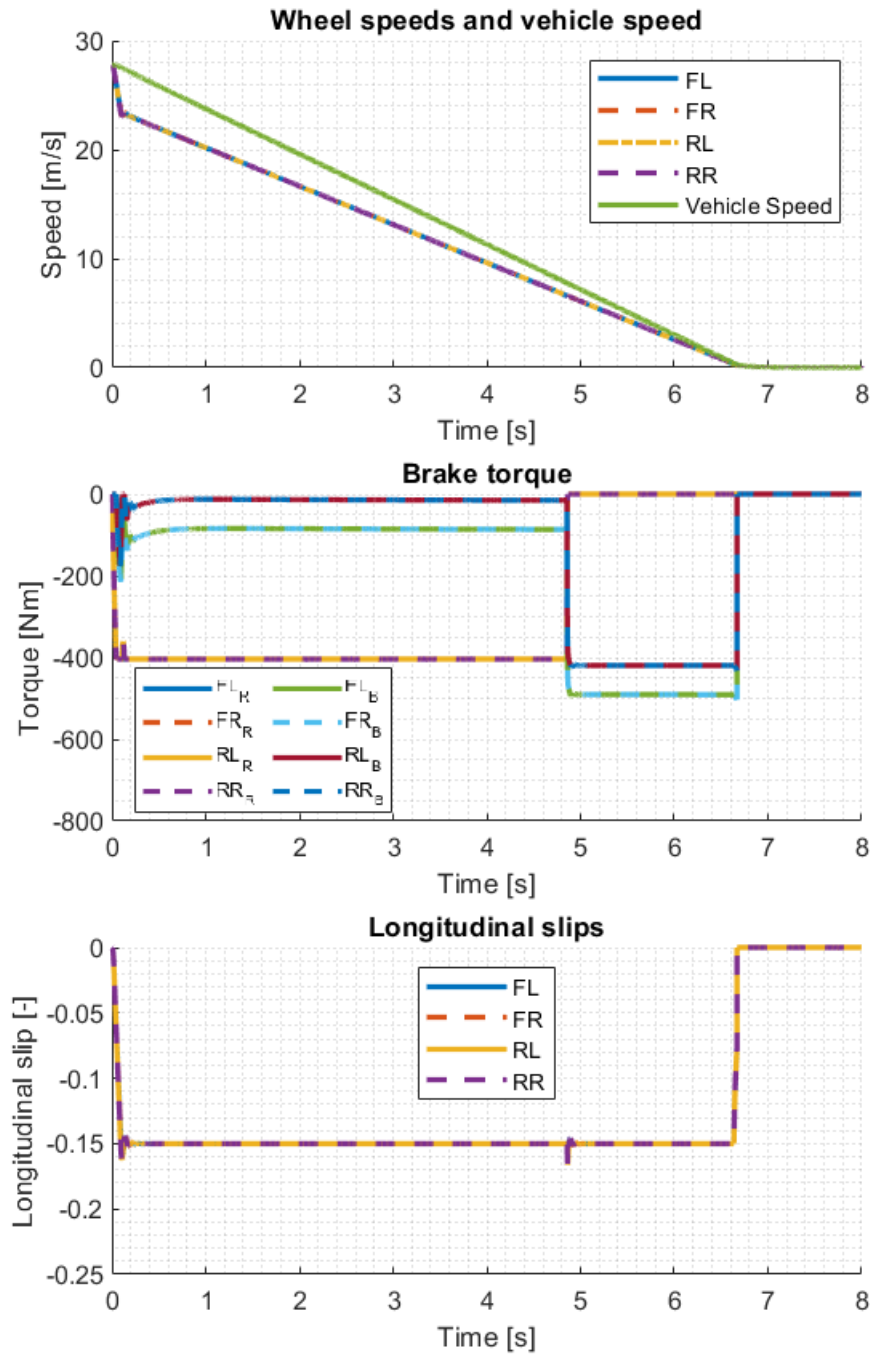

Figure B.8: Test scenario no.2 - emergency braking for $k = 0.2$ using regenerative ABS. Generated brake torques, wheel speeds and longitudinal slips.

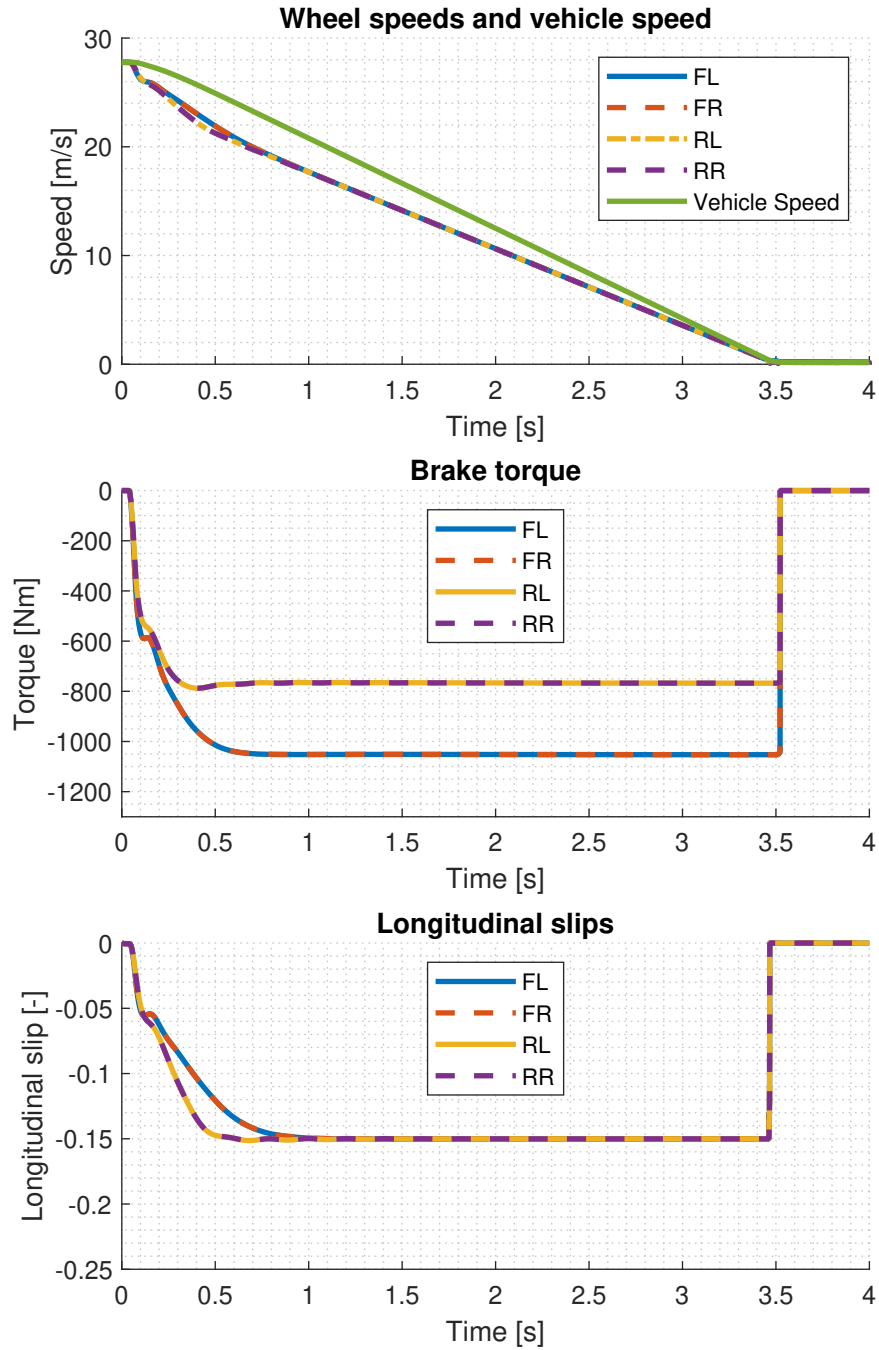

Figure B.9: Test scenario no.2 - emergency braking for $k = 0.4$ using hydraulic ABS. Generated brake torques, wheel speeds and longitudinal slips.

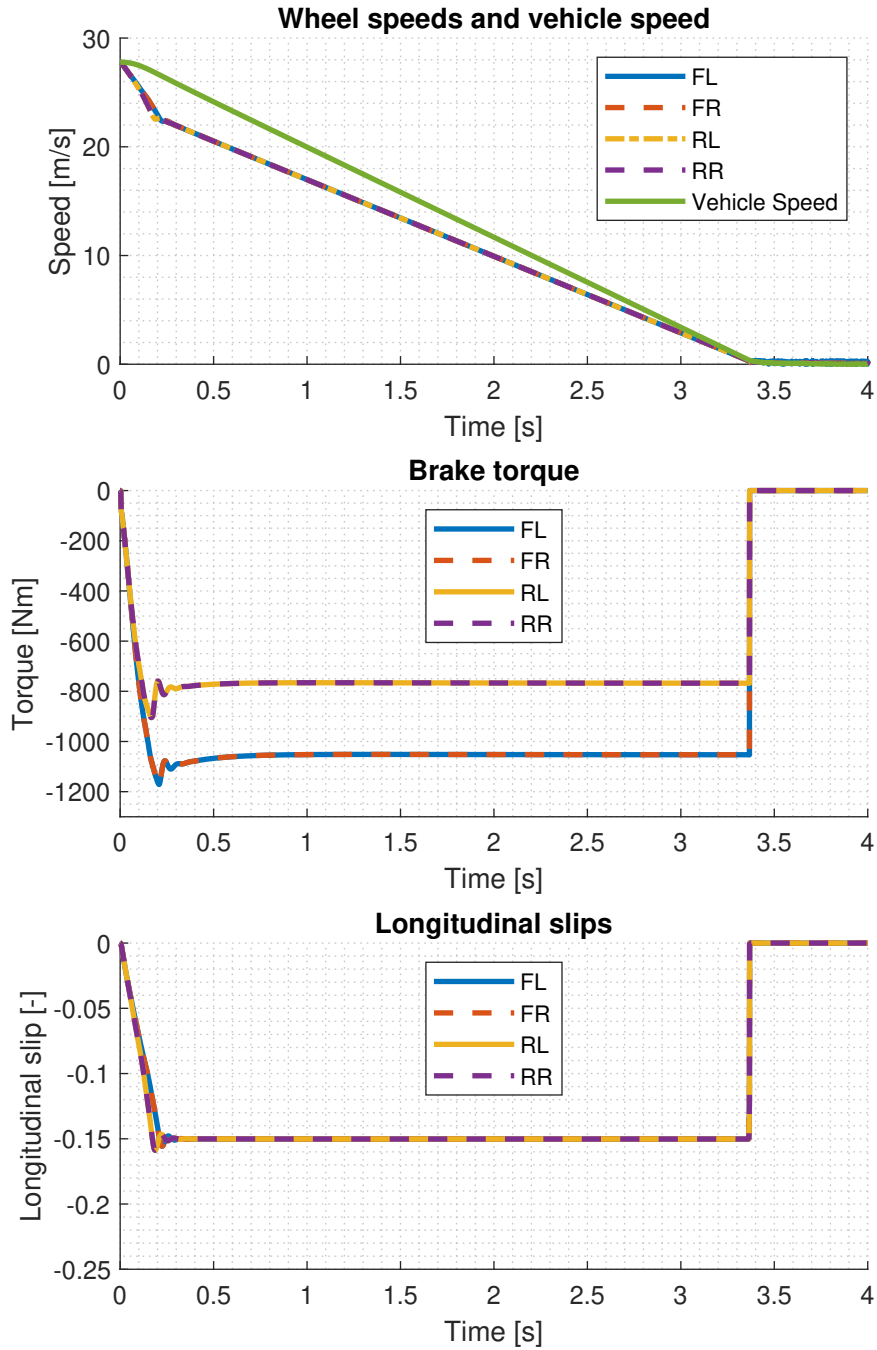

Figure B.10: Test scenario no.2 - emergency braking for $k = 0.4$ using brake by wire ABS. Generated brake torques, wheel speeds and longitudinal slips.

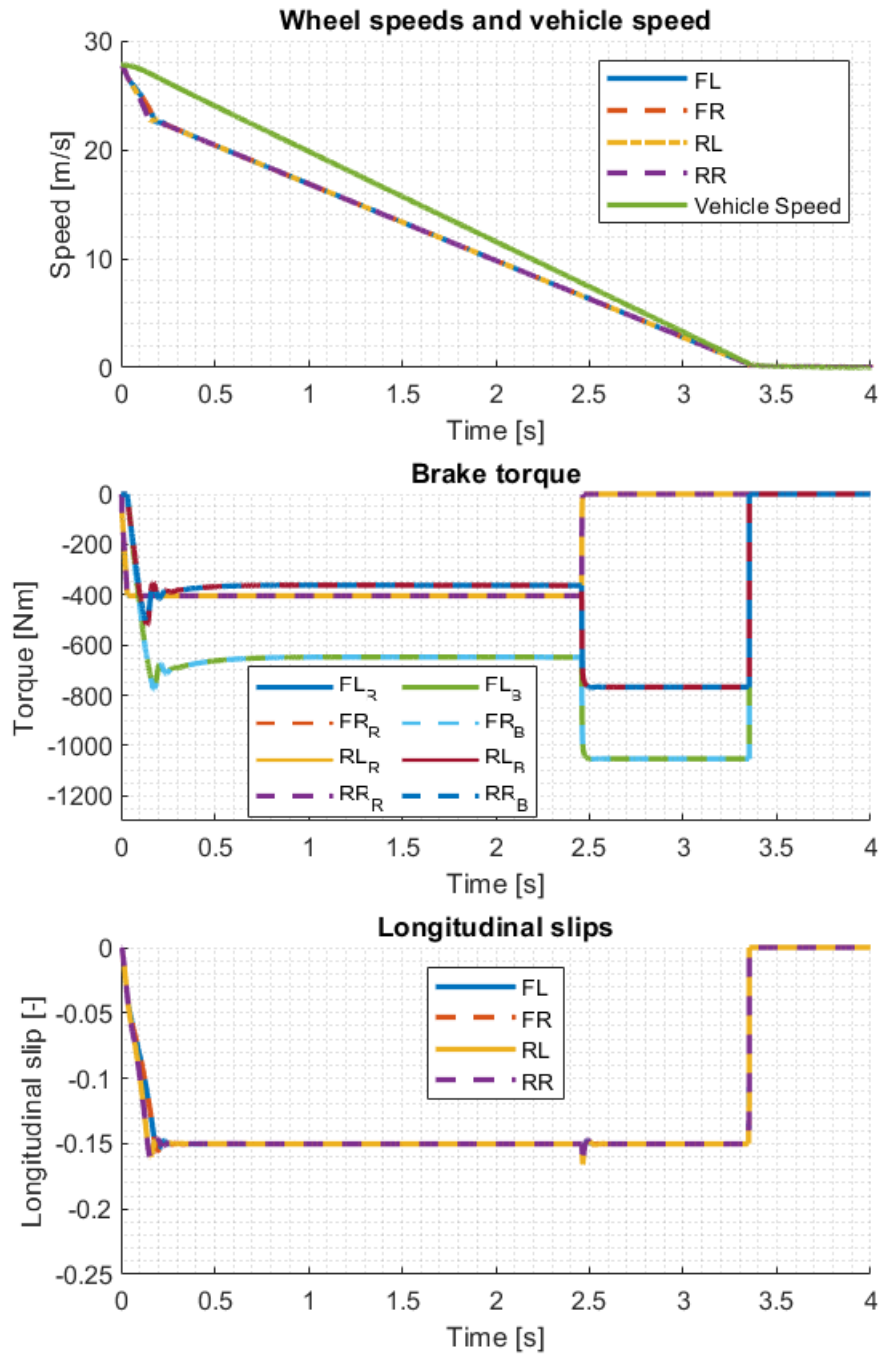

Figure B.11: Test scenario no.2 - emergency braking for $k = 0.4$ using regenerative ABS. Generated brake torques, wheel speeds and longitudinal slips.

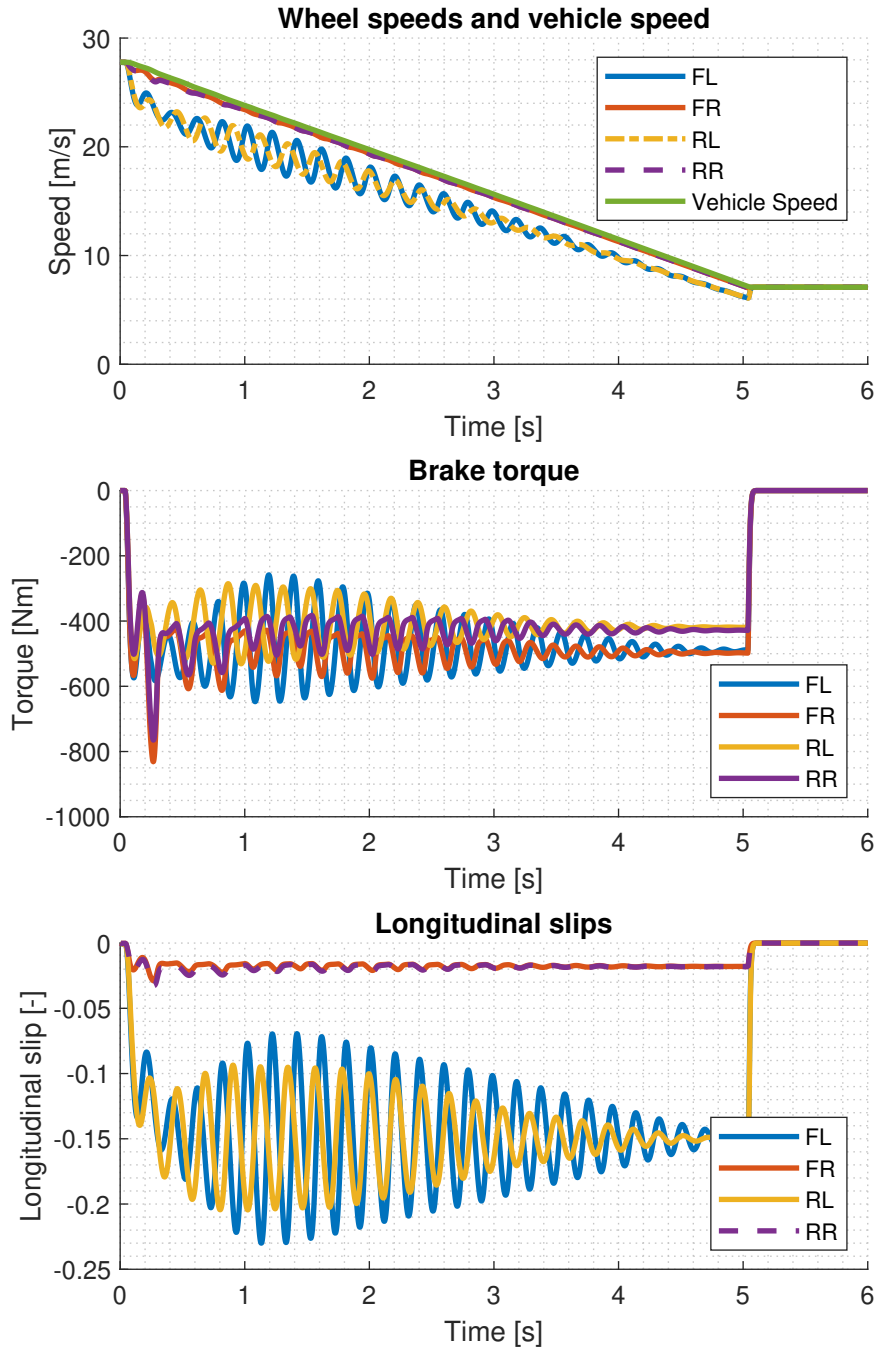

Figure B.12: Test scenario no.3 - μ -split conditions, using hydraulic ABS. On the left side $k = 0.2$, on the right side $k = 1$.

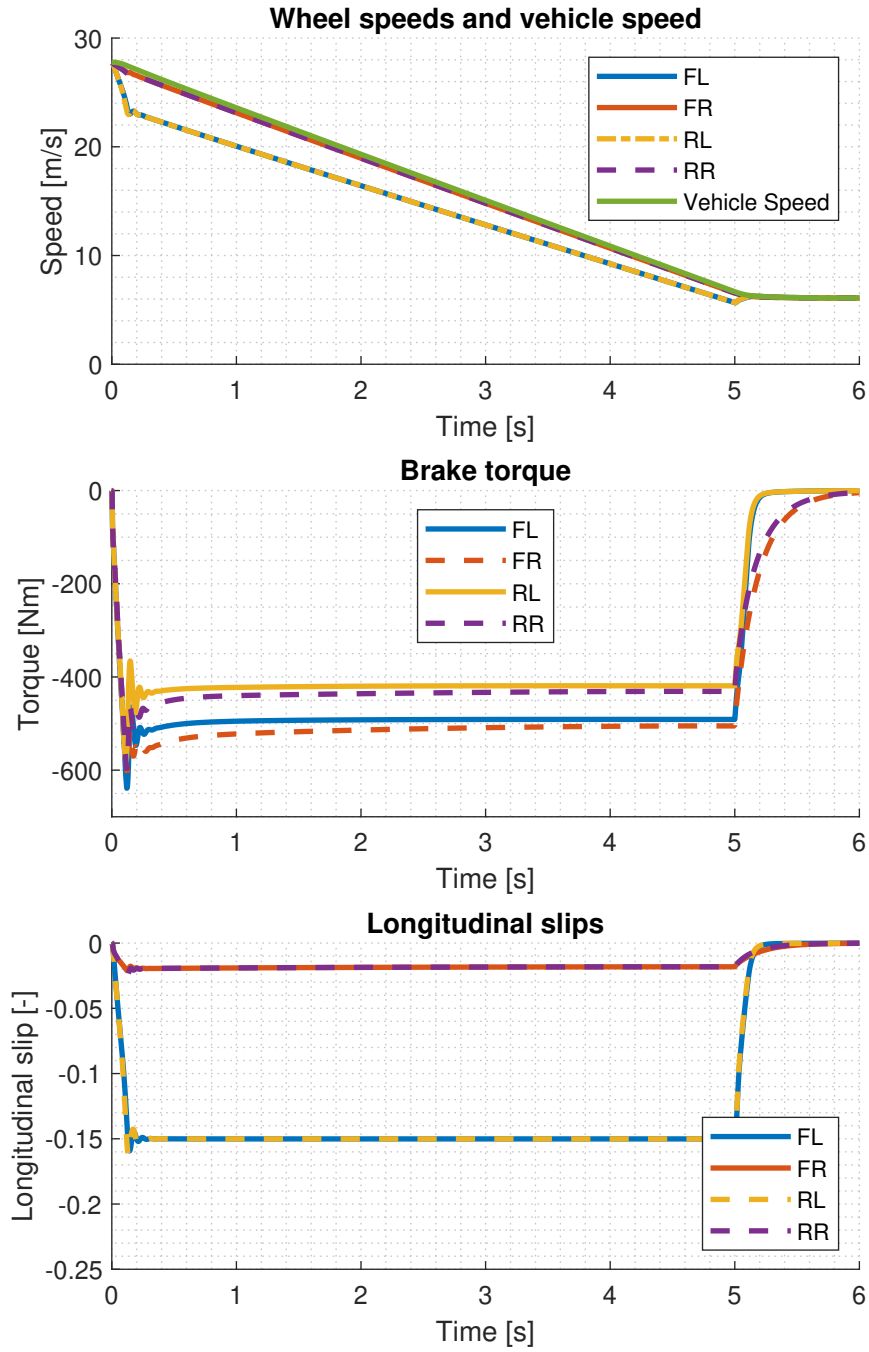

Figure B.13: Test scenario no.3 - μ -split conditions, using brake by wire ABS. On the left side $k = 0.2$, on the right side $k = 1$.

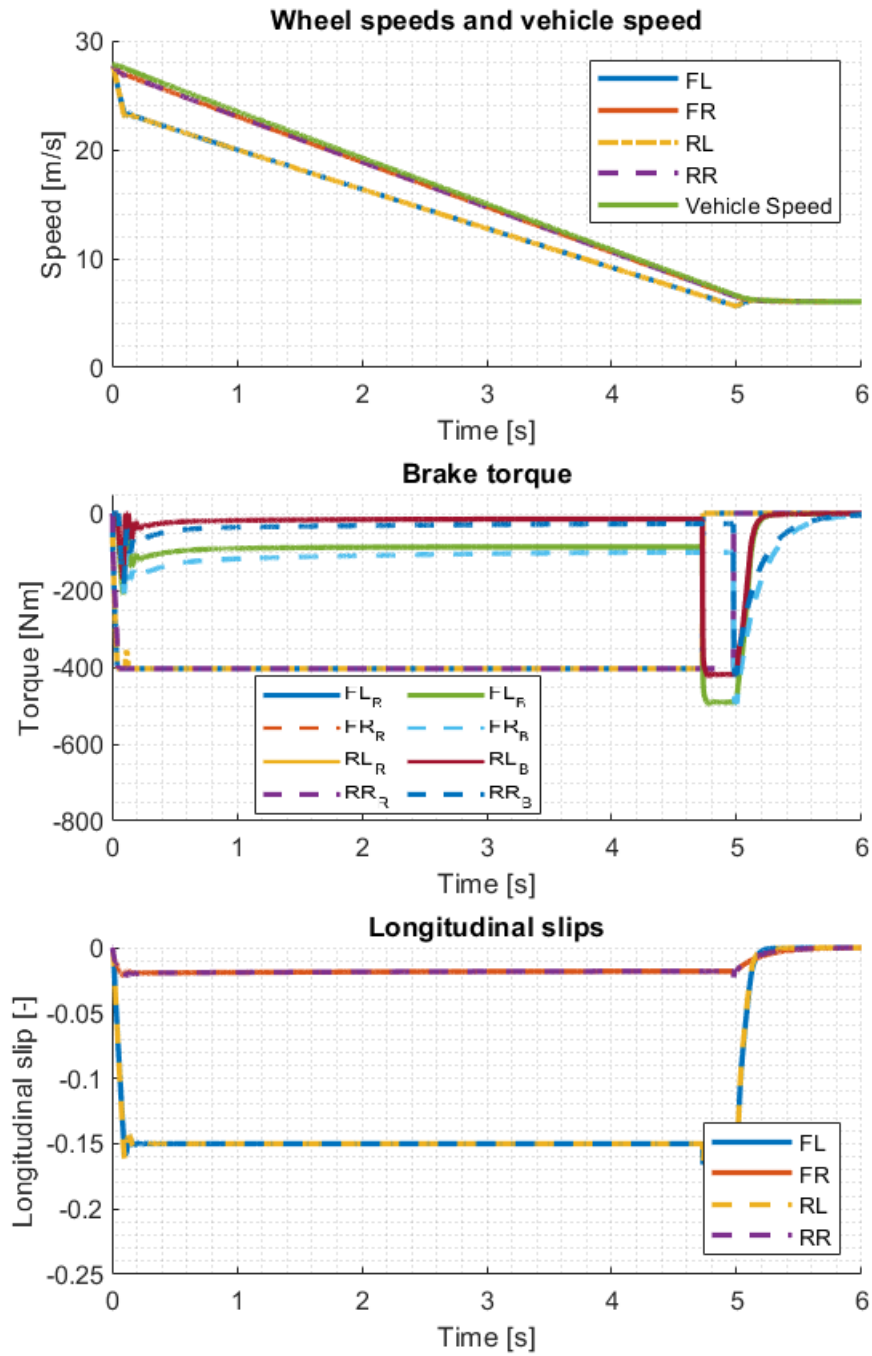

Figure B.14: Test scenario no.3 - μ -split conditions, using regenerative ABS. On the left side $k = 0.2$, on the right side $k = 1$.

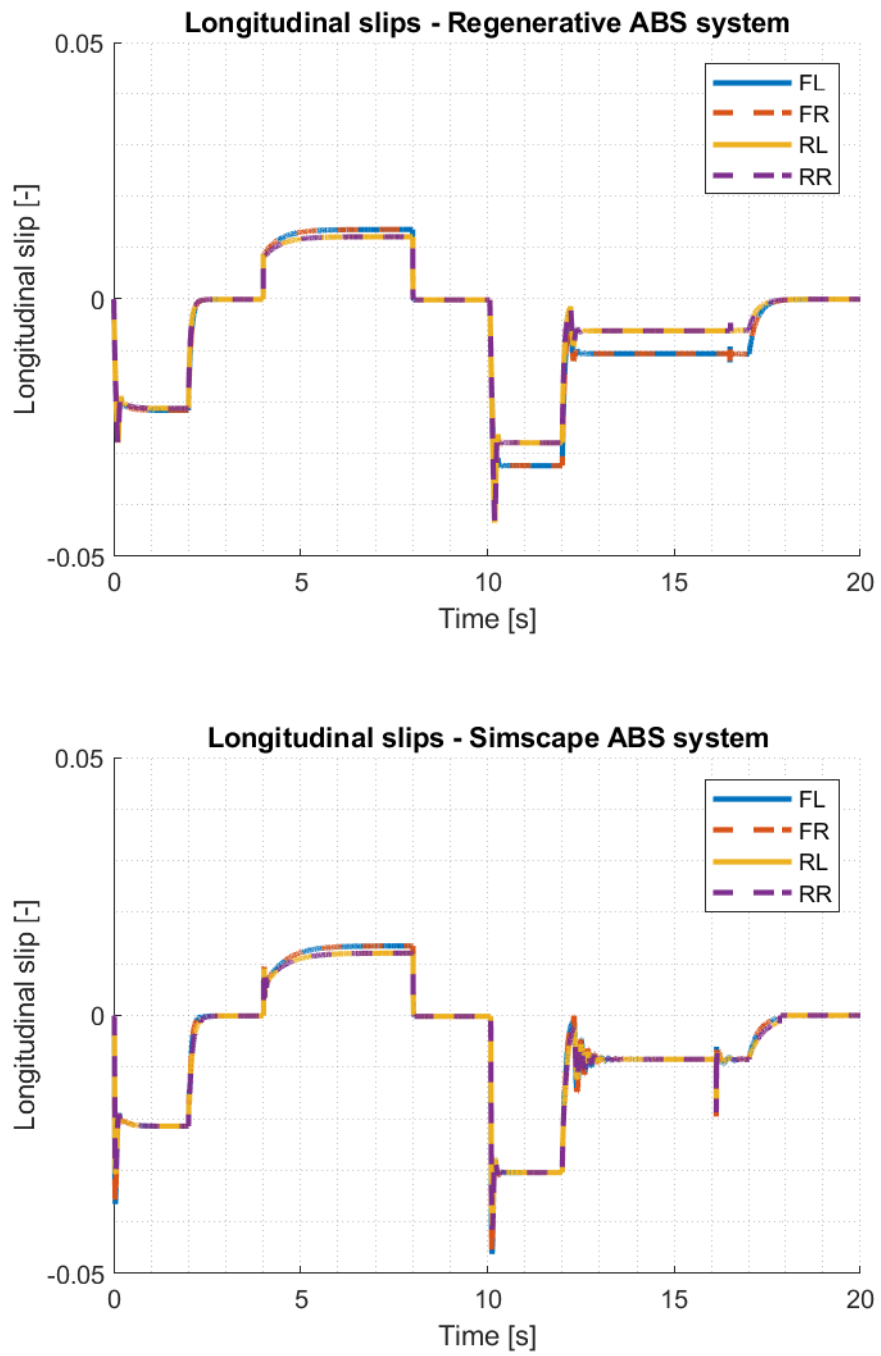

Figure B.15: Test scenario no.1 - input reference tracking. Generated longitudinal slips.

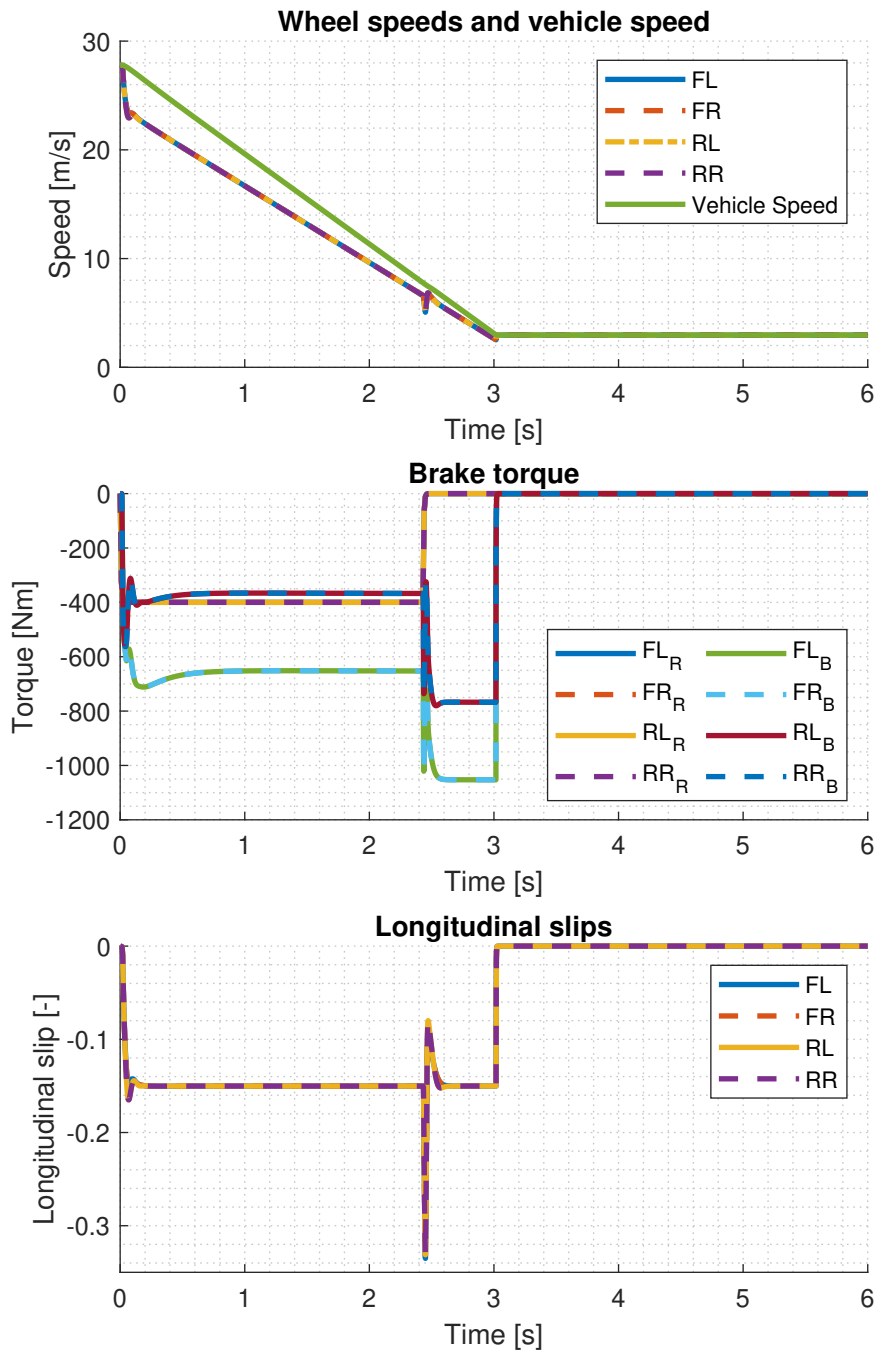

Figure B.16: Test scenario no.2 - emergency braking for $k = 0.4$ using Simscape regenerative ABS. Generated brake torques, wheel speeds and longitudinal slips.

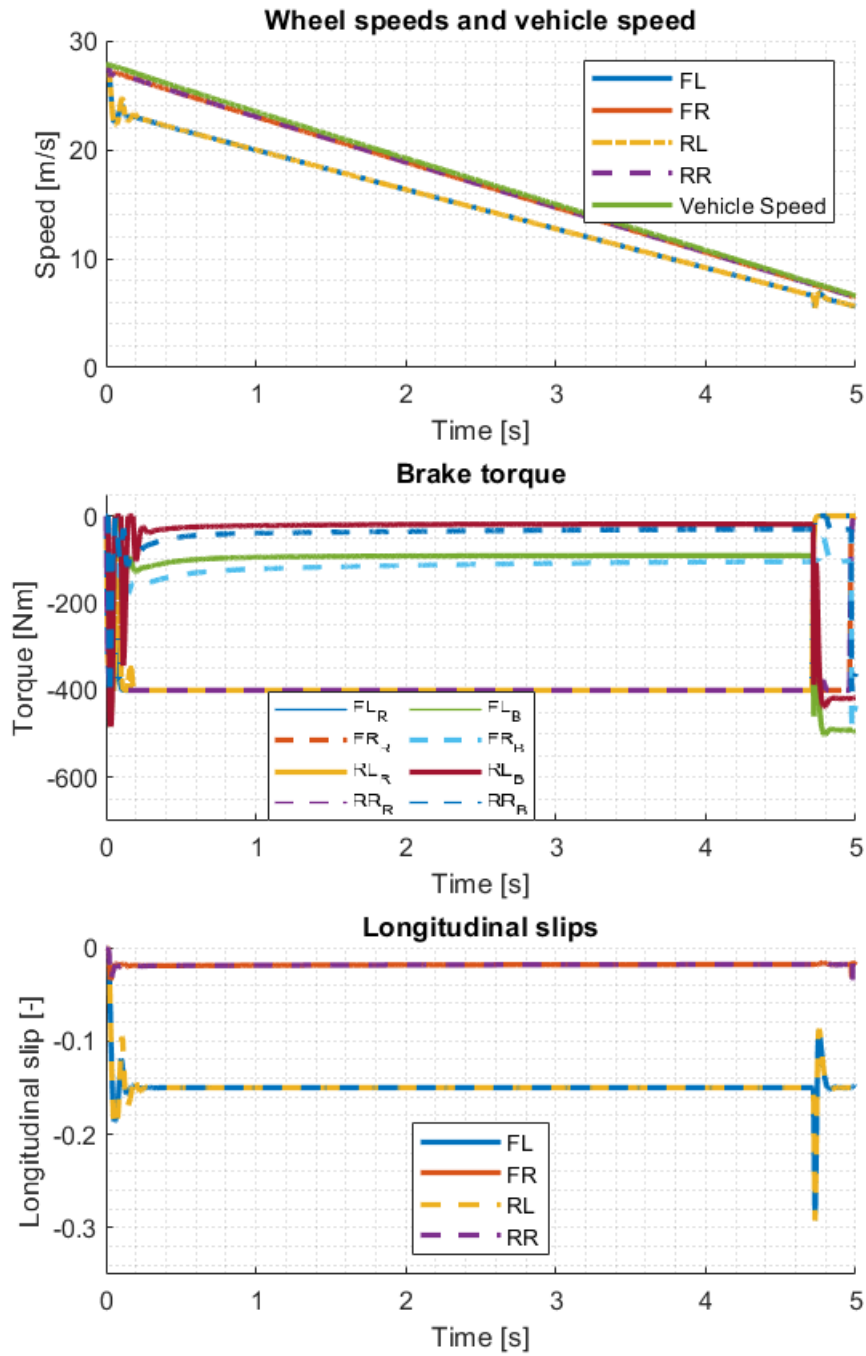

Figure B.17: Test scenario no.3 - μ -split conditions, using Simscape regenerative ABS. On the left side $k = 0.2$, on the right side $k = 1$.

Appendix C

Parameters of used models

Name	Value	Unit	Description
m	1300	kg	Mass of vehicle body
g	9.81	m/s^{-2}	Gravitational constant
J_{xx}	200	$kg \cdot m^2$	Moment of inertia in x -axis
J_{yy}	1300	$kg \cdot m^2$	Moment of inertia in y -axis
J_{zz}	1400	$kg \cdot m^2$	Moment of inertia in z -axis
S_z	0.25	m	Vertical distance between CG and spring anchor
wheelbase	2.745	m	wheelbase
c_w	0.18	–	Drag coefficient
ρ	1.22	$kg \cdot m^{-3}$	Air density
A	2	m^2	Area exposed to aerodynamic forces
J_w	1	$kg \cdot m^2$	Wheel moment of inertia
r	0.33	m	Wheel radius
$c_{a,1,3}$	30000	N/kg	Front spring stiffness
$c_{a,2,4}$	40000	N/kg	Rear spring stiffness
$d_{a,1,3}$	8000	$N \cdot s/m$	Front damping coefficient
$d_{a,2,4}$	8000	$N \cdot s/m$	Rear damping coefficient

Table C.1: Vehicle body parameters. Adopted from [Cib19].

Name	Value	Unit	Description
c_{piston}	0.001	$N \cdot s/m$	Damping coefficient for TMC pistons
m	0.2	kg	Piston mass
V_d	10^{-6}	m^3	Brake circuit dead volume
A_1	10^{-4}	m^2	Compensating orifice area
A_2	10^{-5}	m^2	Brake circuit orifice area
p_0	10^5	Pa	Initial pressure condition
p_{max}	$15 \cdot 10^5$	Pa	Maximal pressure
k_{hs}	10^8	N/m	Hard stop stiffness
c_{hs}	10^6	$N \cdot s/m$	Hard stop damping coefficient
d	$31.75 \cdot 10^{-3}$	m	TMC piston diameter
k_{spring}	$2.7759 \cdot 10^4$	N/m	Spring stiffness
$stroke$	$15.5 \cdot 10^{-3}$	m	Piston stroke
$disp$	$11 \cdot 10^{-6}$	m^3	Circuit displacement

Table C.2: Parameters of used Simscape tandem master cylinder model

Name	Value	Unit	Description
d_{pist}	$57 \cdot 10^{-3}$	m	Caliper disc brake piston diameter
l_{clear}	0.0005	m	Caliper disk brake running clearance
N	2	–	Number of pistons per caliper
$c_{caliper}$	1000	$N \cdot s/m$	Damping coefficient for caliper disk brake
$m_{caliper}$	0.2	kg	Moving component mass in caliper disc brake
r	0.13	m	Effective radius
μ_d	0.4	–	Kinetic friction coefficient
μ_s	0.45	–	Static friction coefficient
l_{dv}	0.0005	m	Caliper disc brake piston cylinder dead volume length

Table C.3: Parameters of used Simscape brake caliper system

Name	Value	Unit	Description
PM	0.1	Wb	Permanent magnet flux
N	6	–	Number of pole pairs
L_d	0.0002	H	D-axis inductance
L_q	0.0002	H	Q-axis inductance
L_0	0.00018	H	Zero-sequence inductance
R_s	0.013	Ω	Stator resistance
I_{max}	800	A	Maximal stator current (peak value)
f_{sw}	2000	Hz	Switching frequency
T_{max}	720	$N \cdot m$	Maximal torque
P_{max}	75	kW	Maximal power

Table C.4: Parameters of used electrical motor



Appendix D

Attachment

The following files are attached to the thesis

```
brake_by_wire.slx  
brake_caliper.m  
hydraulic_brake.slx  
Init_car.m  
motor.slx  
motor_init.m  
tandem_master_cylinder.m  
twin_track_model.slx  
twin_track_model_with_simscape
```