

A (1:2)

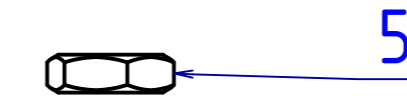

5

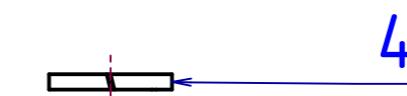

4

B (1:2)

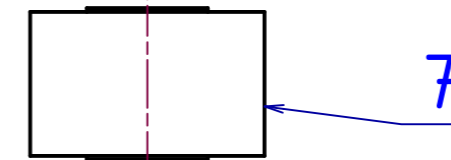

7

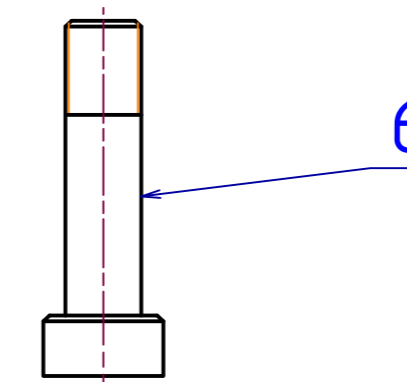

6

C (1:2)

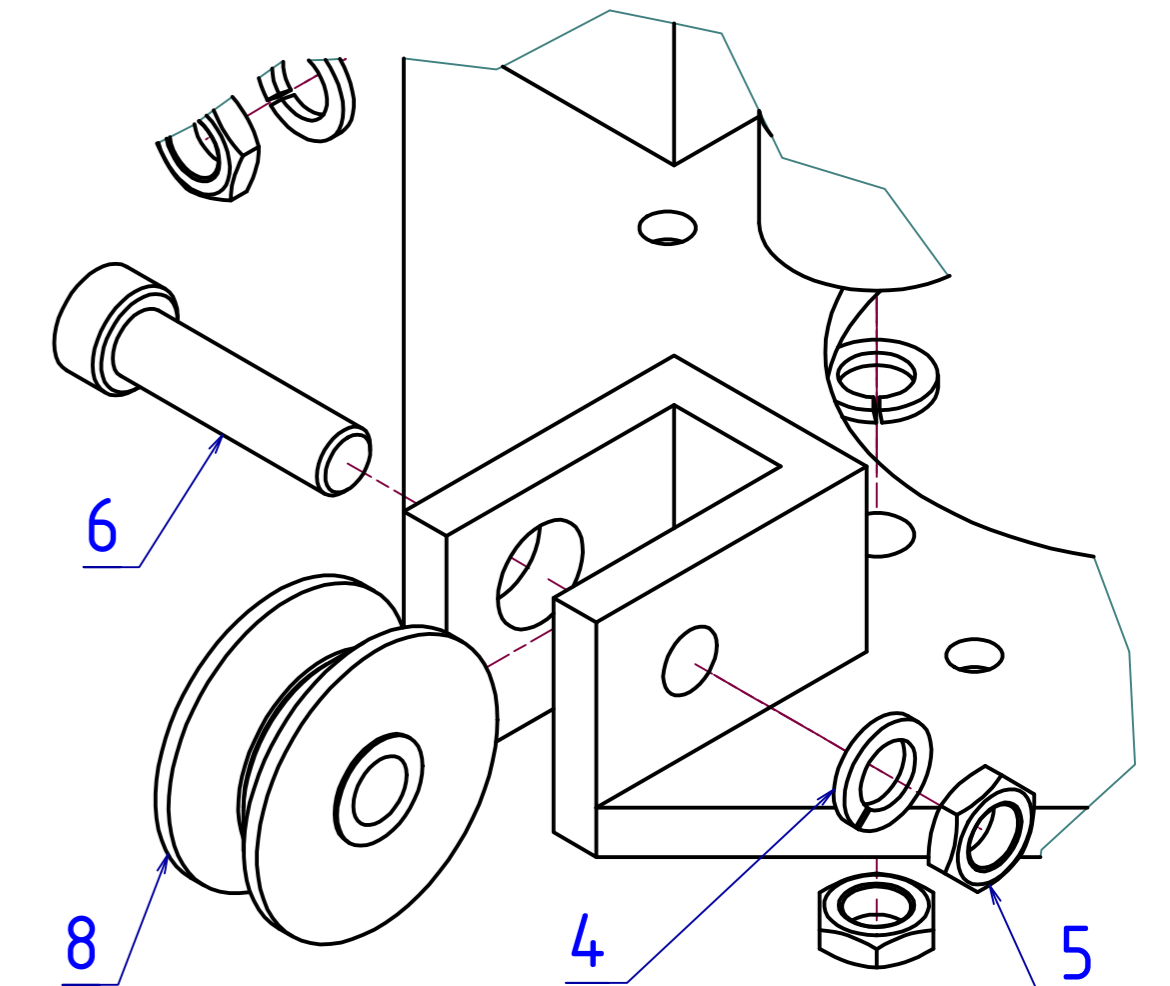

8	ROLNA T.E.A. TECHNIK HPVAG2				1,020 kg	8
7	ROLNA T.E.A. TECHNIK HPCA62				0,810 kg	8
6	UPÍNAČÍ ČEP T.E.A. TECHNIK MSHA20				0,700 kg	16
5	ŠESTIHRANNÁ MATICE	ISO 8675	M20		0,038 kg	16
4	PODLOŽKA	ČSN 02 1741	20		0,015 kg	16
3	SPOJOVACÍ TRUBKA			S355J2H	27,623 kg	1
2	DESKA DOLNÍ	SVARENEC			22,188 kg	1
1	DESKA HORNÍ	SVARENEC			22,188 kg	1
POZ	NÁZEV	NORMA	ROZMĚR	Č. VÝKRESU	MATERIÁL	HMOTNOST KS

NAVŘEL	Dolejš Jaroslav	Datum	13.6.2019	PŘEZK.		Podpis		Datum		HMOTNOST	98,693 kg	MĚŘÍTKO	1:5
KRESLIL	Dolejš Jaroslav	Datum	25.6.2019	SCHVÁLIL						SESTAVA		PROMÍTÁNÍ	ISO E
										NÁZEV VOZÍK BEZ POHONU		TYP: S-01-02-02	
ČESKÉ VYSOKÉ UČENÍ TECHNICKÉ V PRAZE FAKULTA STROJNÍ										ČÍSLO VÝKRESU S-01-02-02			