

Bachelor's thesis



**ČESKÉ
VYSOKÉ
UČENÍ
TECHNICKÉ
V PRAZE**

Faculty of electronics

Department of microelectronics

Autonomous Power Supply for IoT Applications

Author: Čeněk Pěč

Project leader: Ing. Vladimír Janíček Ph.D.

While studying: Electronics and communication

May 2019



ZADÁNÍ BAKALÁŘSKÉ PRÁCE

I. OSOBNÍ A STUDIJNÍ ÚDAJE

Příjmení: **Pěč** Jméno: **Čeněk** Osobní číslo: **466027**
Fakulta/ústav: **Fakulta elektrotechnická**
Zadávající katedra/ústav: **Katedra mikroelektroniky**
Studijní program: **Elektronika a komunikace**

II. ÚDAJE K BAKALÁŘSKÉ PRÁCI

Název bakalářské práce:

Autonomní napájecí zdroj pro aplikace IoT

Název bakalářské práce anglicky:

Autonomous Power Supply for IoT Applications

Pokyny pro vypracování:

- 1) Seznamte se s problematikou napájecích zdrojů optimalizovaných pro aplikace IoT.
- 2) Proveďte analýzu efektivity obnovitelných zdrojů využitelných pro nízkopříkonové aplikace IoT.
- 3) Navrhněte koncept univerzálního modulu pro power management, napájeného z obnovitelných zdrojů (např. solární články) se zásobním akumulátorem. Modul bude využit jako zdroj elektrické energie pro IoT aplikace. Pracovní módy modulu budou zařízení IoT signalizovány pomocí stavových signálů (flag register).
- 4) Realizujte funkční vzorek ve formě prototypu.
- 5) Proveďte ověření technických parametrů a diskutujte energetickou bilanci zařízení.

Seznam doporučené literatury:

- 1) P. M. Parker, The 2020-2025 World Outlook for Energy Harvesters, ASIN B07N3RGGVV
- 2) T. Christen, Efficiency and Power in Energy Conversion and Storage: Basic Physical Concepts, ISBN-13: 978-1138626638
- 3) Y. Kheng Tan, M. Wong, Energy Harvesting Systems for IoT Applications: Generation, Storage, and Power Management, ISBN-13: 978-1498717250

Jméno a pracoviště vedoucí(ho) bakalářské práce:

Ing. Vladimír Janíček, Ph.D., katedra mikroelektroniky FEL

Jméno a pracoviště druhé(ho) vedoucí(ho) nebo konzultanta(ky) bakalářské práce:

Datum zadání bakalářské práce: **13.02.2019**

Termín odevzdání bakalářské práce: **24.05.2019**

Platnost zadání bakalářské práce: **20.09.2020**

Ing. Vladimír Janíček, Ph.D.
podpis vedoucí(ho) práce

podpis vedoucí(ho) ústavu/katedry

prof. Ing. Pavel Ripka, CSc.
podpis děkana(ky)

III. PŘEVZETÍ ZADÁNÍ

Student bere na vědomí, že je povinen vypracovat bakalářskou práci samostatně, bez cizí pomoci, s výjimkou poskytnutých konzultací. Seznam použité literatury, jiných pramenů a jmen konzultantů je třeba uvést v bakalářské práci.

Datum převzetí zadání

Podpis studenta

Declaration:

I declare I have accomplished my bachelor project by myself and I have named all the sources used in accordance with the Guideline on ethical preparation of university theses.

In Prague on 24. May of 2019

.....

Čeněk Pěč

Acknowledgement

Prima facie, I am grateful to the Universe for the good health and wellbeing that were necessary to complete my thesis.

I wish to express my sincere thanks to Emma Lutheránová, Julia Rose Majzun and Petr Balvín, for helping me selflessly and for preparing me for this task.

I place on record, my sincere thank you to my family, for the continuous encouragement and support throughout my journey.

I am also grateful to Ing. Vladimír Janíček Ph.D., lecturer in the Department of Microelectronics. I am extremely thankful and indebted to him for sharing expertise, and sincere and valuable guidance and encouragement extended to me.

I take this opportunity to express gratitude to all members of FELita group, my problems seemed lesser when debated with you over a glass of a beer, which lead to me staying a student at this school.

Abstract

The aim of this bachelor thesis is to create an autonomous power harvesting device which would be able to power to supply enough energy to create a completely independent IoT node. Solar panels were chosen as a source from among researched options along with accumulators for power storage. For power management LT3652 was used along with potentiometer and jumper setup to allow for variability in power input/output. Output regulation was secured with low-dropout regulator to increase efficiency. Circuit was then designed, printed and set up. 3D chassis was designed for optimal protection of the board. Measurements were then made, and energy balance drafted.

Keywords: IoT, Power harvesting, Autonomous power source, 3D printing

Project leader: to Ing. Vladimír Janíček
Ph.D. Department of Microelectronics
ČVUT v Praze, Technická 2 166 27 Praha

Abstrakt

Cíl této bakalářské práce je vytvořit samostatnou jednotku, která by byla schopná napájet IoT uzel. Solární panely byly vybrány jako zdroj energie pro dobíjení akumulátorů ze všech zkoumaných možností. Pro správu energie byl použit čip LT3652 s trimrem a jumperem ovladatelným boardem, což by mělo zajistit ovladatelnost vstupu a výstupu. Dále byl použit nízkoztrátový regulátor pro řízení výstupního napětí a udržení vysoké efektivy obvodu. Dále byl obvod vymodelován, vytisknut a osazen. Pomocí 3D tiskárny bylo vytvořeno pouzdro pro celou jednotku. Dále proběhlo měření a energetická bilance.

Klíčová slova: IoT, Power harvesting, Autonomní zdroj, 3D tisk

Contents

Contents	9
Motivation	11
Theoretical part.....	13
Solar energy.....	13
Radio frequency (RF) based energy	14
Wind energy	15
Thermal energy.....	15
Choice of suitable power source.....	15
Function analysis	16
Solar panels	17
Modes.....	17
Power management.....	17
Accumulators.....	18
Schematic and parts	19
Output regulation	19
LT3652.....	20
P1, P2 pins.....	21
Chassis	22
Printed Circuit Board.....	24
Measurements.....	27
Measuring the panels	27
Measuring controller.....	27
Measuring the board	28
Energy balance	29
Future improvements	30

Conclusion.....	31
References	32
List of parts	35

Figures

Figure 1: IoT visualization	12
Figure 2: Position of sun on the sky throughout the day	14
Figure 3: RF-based energy harvesting board	14
Figure 4 Function schematics.....	16
Figure 5: LT3652 function logic	17
Figure 6: Circuit design	19
Figure 7: LDO circuit setup,	20
Figure 8: Voltage regulation diagram.....	21
Figure 9: Top view of the chassis.....	23
Figure 10: Bottom view of the chassis.....	23
Figure 11, 12: Top and bottom layers of PCB	24
Figure 13: Panel serial/parallel switching with jumpers.....	25
Figure 14: PCB with parts.....	26
Figure 15: PCB with parts.....	36

Motivation

The subject for this thesis was chosen after careful consideration to be a standalone power solution. As our world slowly starts converting from wired to wire-less a new type of power supply is needed to supplement those from an old era. Obviously not everything needs to be powered without connection to mains network. It is more the peripheries such as temperature, humidity, barometric pressure sensors. Possibilities are almost infinite if a reasonably big object can be a self-sustainable or sudo self-sustainable unit. Agricultural uses come to mind when power supply is no longer bound to any specific place or its proximity. For example, small devices that could measure weather conditions would be helpful in remote places. This allows for monitoring of cattle without any big expanses like repetitive use of fuel and man days just to check if everything is as should, when this all could be done by a small object possibly connected to a Wi-Fi or cellular network.

With the recent growth of IoT technologies it has become affordable to build a network containing dozens of different sensors and gadgets to improve quality and ease of life. This has also been a motivation behind this thesis. All-purpose power solution for low-power electronics that would be cheap, efficient, independent and adjustable so that it could suit anyone and everyone with their needs. Batteries can offer a long-lasting lifetime and are affordable, but after a certain period of the time need to be replaced or recharged. That could prove inconvenient or even impossible for certain remote applications.

At the current rate of progress, it is expected that the number of deployed wireless sensor nodes in the world will approximately be 50 billion by the year 2025. However, to reach that vision there are still many practical problems that must be solved. One of them is how to embed everywhere that massive number of devices in a sustainable manner [1]. Even if only one a fraction of these will need to be powered by alternative sources, it is still a non-neglectable number of applications. There are some projects that use solar energy for powering certain sensors or low-power electronics, but none that would provide a complete and free solution for an uneducated end customer.

At a time when this thesis was made no solutions were to be found on the internet under basic keywords like ‘solar power harvesting’, ‘solar IoT harvester’ etc. which proves that this topic needs to be researched more and invested into, since it can very well be the future of wireless sensors. The decision was made to create a whole and self-sufficient system which is cheap and usable in

most conditions. After some research solar energy was chosen to be the source for this power solution for its low cost, versatility and efficiency compared to size.



Figure 1: IoT visualization [25]

Theoretical part

As the sensor technology becomes more advanced and the production costs go down, the technology itself becomes more affordable. This leads to an increase in usage of these technologies, especially in IoT. The topology of such a network can be difficult to create and is now made easier with the use of Wi-Fi or other wireless protocols to ensure easy installation and information sharing. It is however challenging or not feasible in some cases to power local nodes from mains or a generator.

There are different methods of maintaining long term usability of an IoT node. In some applications, energy efficient design can be supplemented with energy-for-data trade-off [2], allowing the extension of node operational life, albeit at the cost of sub-optimal data collection rates. Next, primary (non-rechargeable) batteries can be used. However, these batteries have a downside of requiring maintenance which in some cases might prove to be expensive or non-viable option. Energy harvesting devices offer an alternative (or supplement) to primary batteries that can greatly extend the lifetime of EWSN devices [3]. Harvesting sources are often combined with primary batteries and other energy storage devices [4]. Energy harvesting is a process of acquiring energy from accessible external sources to either store it for later use or to power electronic devices.

Energy harvesting sources can be categorized as ambient or external [5]. In general, external sources are not fit for IoT use since they require energy intended for this node such as human or mechanical sources (engine). Ambient sources however are present in the surrounding environment without any artificial power source (solar, thermal, wind, radio frequencies - RF). In next chapter different sources for energy harvesting will be discussed.

Solar energy

Solar energy is one of the most popular sources for clean energy power harvesting thanks to its accessibility and price. It also offers a good ratio of size to power production with typical value of power density considered to be around 15 mW/cm² when designing energy harvesting for embedded systems [6]. Most solar panels on the market offer efficiency ranging from 15% to 20%, which for the device that is the subject of this thesis is not as relevant as the form factor compared to its power making capabilities mentioned above [7] [8]. There are of course downsides to this form of energy as well. For example, if the device would be placed behind a window, power produced by it would drop by 50% [9]. The panels also need to be positioned in a specific way to be as efficient as possible, as the angle of the panel can make another 50% difference in power output [10]. This can cause problem in locations with higher latitudes since the sun changes its relative paths and

therefore alter the angle under which the solar rays hit the panel as shown on example for San Francisco, which is closer to equator than the Czech Republic, on figure (2) below [2].

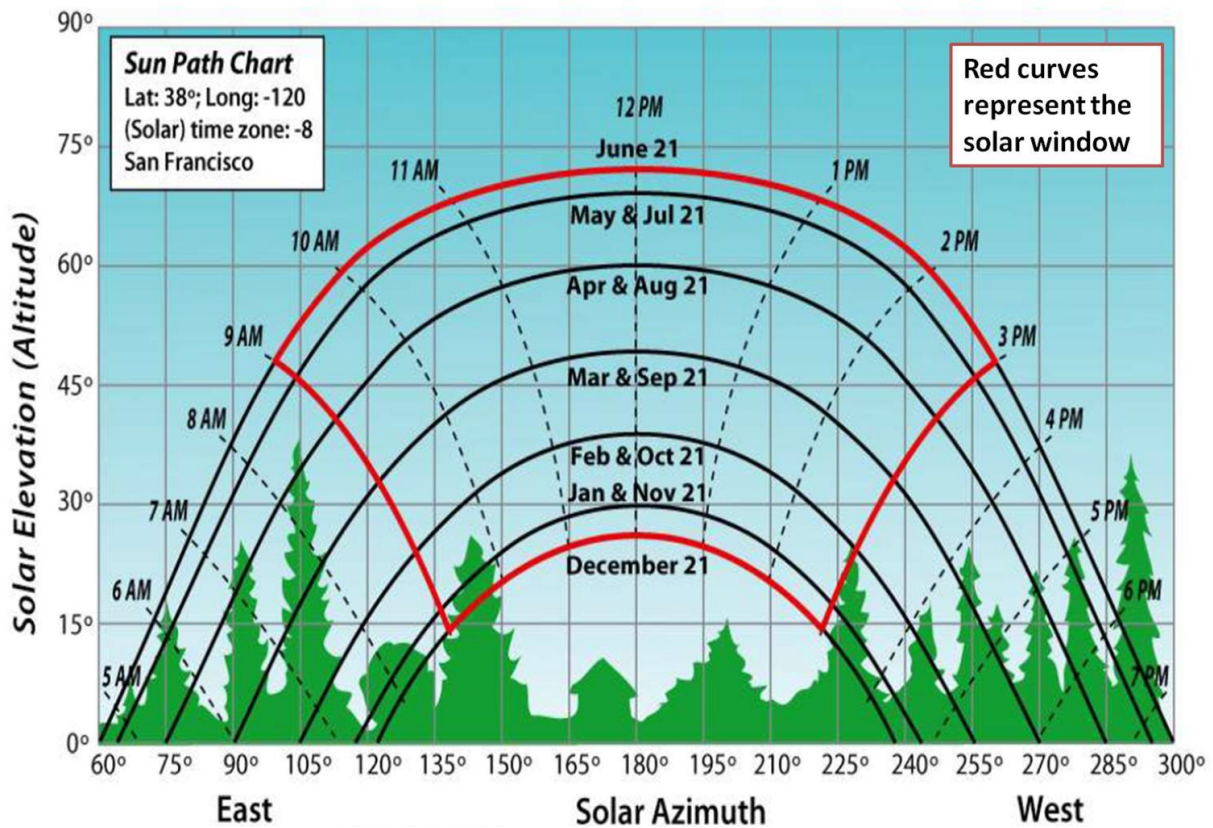

Figure 2: Position of sun on the sky throughout the day [9]

Radio frequency (RF) based energy

Out of all the ambient power sources, RF-based power harvesting technologies are the most recently developed technology and therefore are rarely used outside of laboratories or homes of technology enthusiasts. This technology finds its primary use in cities and larger metropolitan areas as those areas are more saturated with radio frequencies [11]. With conversion efficiency going up to 75% [12] and a practically constant source of energy throughout the day, the potential of growth of this method is extraordinary. The downside of this technology

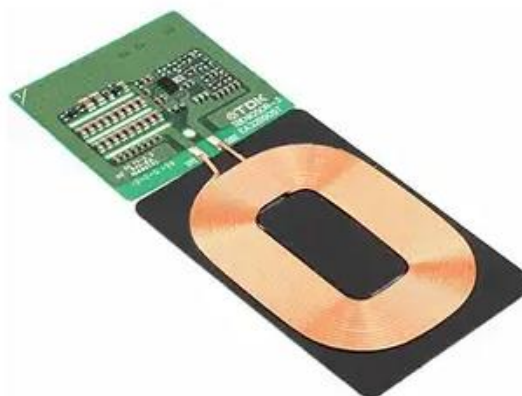

Figure 3: RF-based energy harvesting board

is that the strength of the signal decreases with square of the distance from transmitter, making them less appealing for isolated applications and thus less versatile. Example shown above on Figure (3).

This technology might be future of wireless IoT nodes, however in present day, the cost of making a device that could reliably power IoT node is significant, furthermore coils used to harvest power for the device are also distracting electromagnetic signals and making it harder for the device to communicate, which is seemingly counterproductive for IoT nodes [13].

Wind energy

Wind turbines are, at least in recent technologies, filled with IoT nodes. However, they are using the IoT to power the turbines effectively rather than using them to power the IoT itself. This is due to the fact, that wind is typically less reliable than the sun and requires a more intricate build, increasing the form factor. For example, a wind generator is capable of supplying up to 10 mW using a 6.3 cm diameter turbine at 16 km/h wind speed [14]. Overall, wind offers a great source of energy with bigger power to size ratio of up to 28 mW/cm² [17] and is more than suitable for uses in places such as mountain tops or at seaside; where the wind is always blowing. It is unfortunately less ideal for Prague, where the device will be tested [18]

Thermal energy

Thermal energy harvesting offers the lowest efficiency of about 5% - 6% [15] out of all the ambient power sources. It works thanks to the Seebeck effect. This effect is dependent on Seebeck's coefficient [16] (material's property) and a temperature difference of both the thermoelectric generator ends. These generators allow for harvesting power in environments, where a big difference of temperatures can be used in power plants or automotive industry. In general, this source of energy is very useful in specific environments, however lacks the versatility. [19]

Choice of suitable power source

This choice comes down to specific applications and their requirements. This thesis will be focused on overall versatility and price. That eliminates RF-based power sources and thermal sources for lack of versatility. Wind would be a viable source, however it would be less efficient in the Czech republic in general since the country lacks any large plains where wind would blow a majority of the time. Also, such a build would require a great deal of space and set up. Ultimately, solar energy was chosen due to its ease of use, availability and almost universal usability.

Function analysis

In order to analyze it, the device will be divided into function blocks. You can see the schematic below on figure (4). The blocks will later be discussed as individual entities, the overall function underneath the schematic.

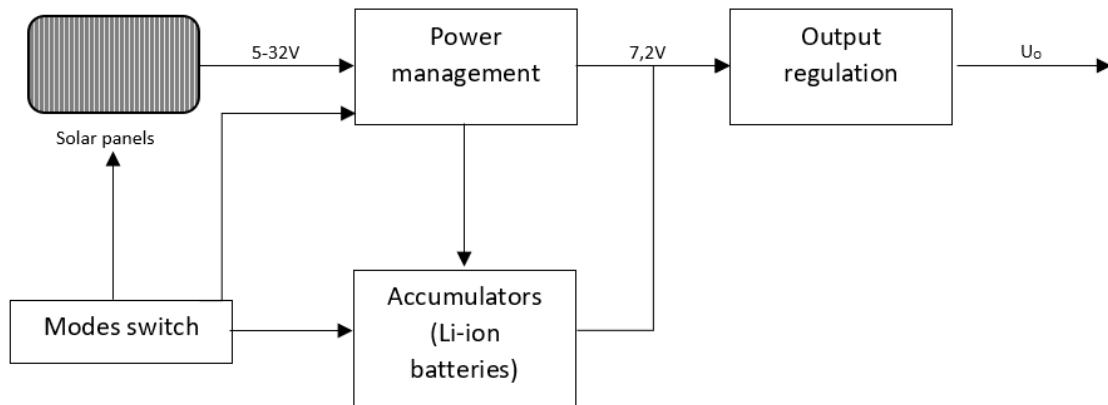

Figure 4 Function schematics

This concept allows for regulation of almost all values that ever need to be regulated. Starting with modes, which allow for switching among parallel or serial connection on both panels and batteries plus required changes on the circuit to make it work properly. This is to make sure that any further iterations of this board will only require little to no work and can be done in short time to make testing and prototyping easier.

Moving on to solar panels which provide the essential input that is power. The possibility of using series or parallel connection along with the choice of solar panels that will be discussed later opens possibility of low-light harvesting with slightly altered board but focus of this work is on maximizing the collected power, so the panels will be in series by default to increase the voltage.

Next block is power management. This is the heart of the whole device and it makes sure as much power as possible will be drained from solar panels using MPPT (Maximum Power Point Tracking), charges the batteries and protects them from under voltage, indicates important data and when needed acts as a short circuit so that current can float from the panels right to the load increasing efficiency.

Batteries are here as a backup source and to store harvested power. Ideally the device will be self-sufficient throughout the year and will not need any external battery charging. This of course depends on amount of sunny days and load that will be connected. Output regulation is important to make sure any device connected will not be harmed by any irregularities in voltage or current flow.

Solar panels

These are obviously the foundation on which rest of the device operates. For ease of operation a small form factor needs to be chosen, but on the other hand it needs to be big enough to power the device without external power supply. Ultimately 2 panels were chosen, each is 11x6 cm and together they offer up to 2 W of power at 132 cm² area.

The choice of two panels was intentional as in specific modifications of the board, the panels can be set in parallel mode to increase current flow. This will be especially helpful in places with bad lighting conditions.

Modes

There are many ways to achieve ability of switching between certain modes, but since this device is value driven, pin headers were chosen for this task. They are way cheaper than any other option and allow for easy and intuitive navigation on the board as long, as they are marked or described on the PCB. As mentioned above solar panels can be connected in parallel or series connection, same for batteries.

The fact that the device can be switched into different modes is what makes it truly universal as the battery and power switches are independent on each other so different iterations of this device can be set up to personalize every board exactly for the purpose it is supposed to fulfill.

Power management

LT3652 chip was used as a main controlling logic on this board for its many functionalities including power tracking on solar panels and ability of charging batteries in cycles. It is built for higher

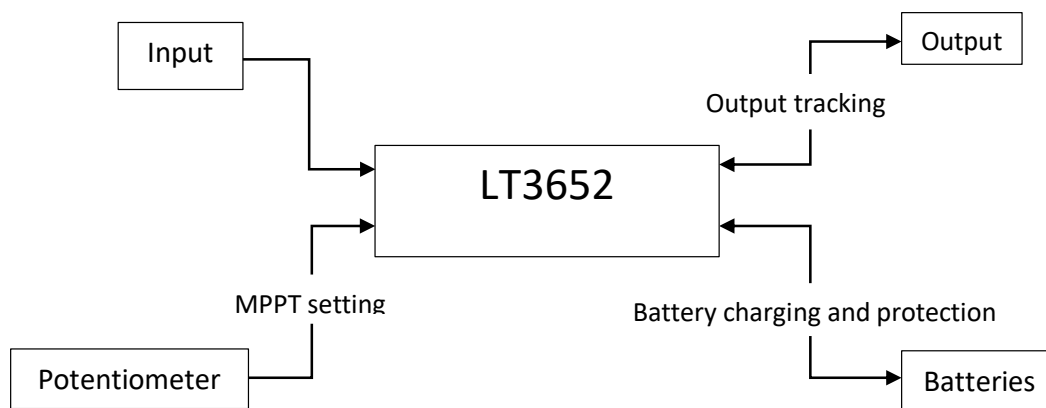

Figure 5: LT3652 function logic

currents and voltages, so the efficiency is not as high as could be, but it opens a possibility of

connecting a big solar panel in case it is needed or requested. Only once component needs to be changed afterwards and the whole board can transform to accommodate up to 30x more power (considering input voltage is at 36V). The chip also has charge and battery fault binary outputs which can be connected to any IoT controller for even more collectable data and to make sure faulty batteries are being replaced. Expanding the range of options for this board, time-based charging cycles can be set up thanks to this chip. They will not be implemented here, however there is the option of implementing them in future builds requiring just a small change in the circuit. Finally, the LT3652 employs an input voltage regulation loop, which reduces charge current if the input voltage falls below a programmed level, set with a resistor divider. When the LT3652 is powered by a solar panel, the input regulation loop is used to maintain the panel at peak output power [20].

Accumulators

Accumulators with capacity of 2200 mAh, Li-ion technology and voltage of 3,6 V were chosen. This decision was made for several reasons including price, need for up to 250 mA of current at peaks and availability of these kinds of accumulators all over the world. Their combination can either let the user switch them to single cell, parallel or series combination as said before. This was done to make sure every type of application could be powered through this device, ranging from low powered controllers being connected, which requires just couple mA of current every now and then ranging all the way up to power hungry controllers which might take up to 250 mA.

Schematic and parts

This device was built with the intention of being modular and that transferred to the board itself. Underneath the schematic as well as parts themselves will be discussed along with the reasons for their inclusion. All the parts can be found in the parts summary attachment.

This schematic was created to be as minimalistic as possible while satisfying all the requirements given. The core was based of typical application circuit given in LT3652 datasheet, however a

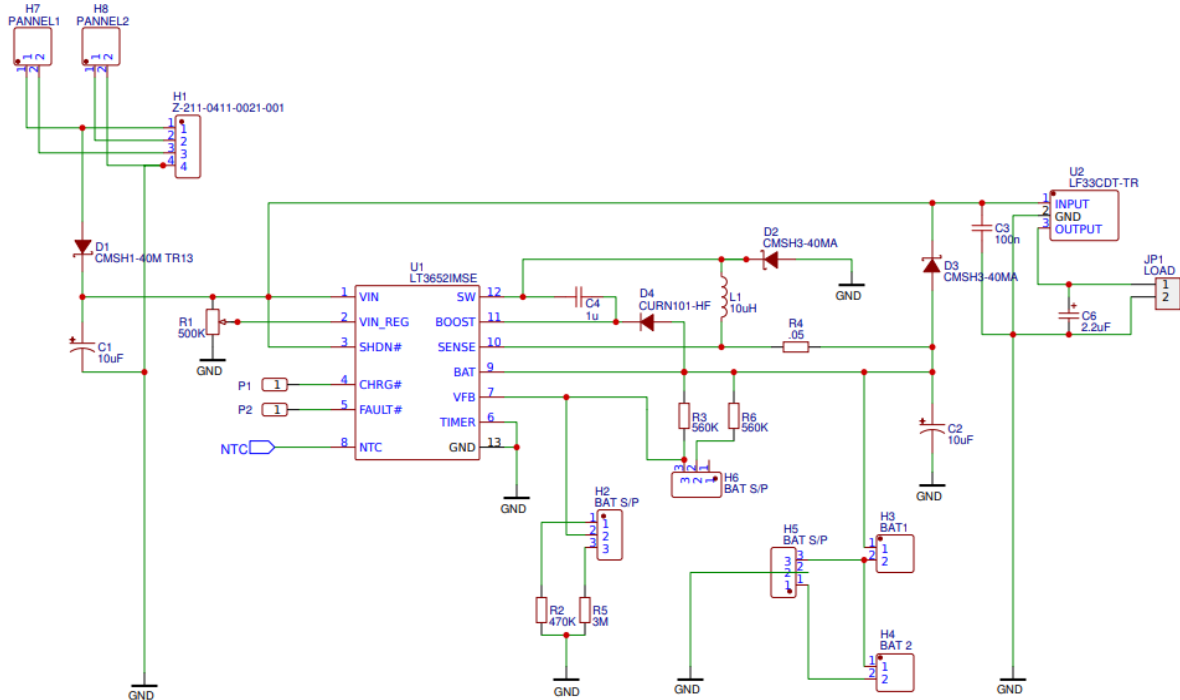

Figure 6: Circuit design, magnified version can be found at the end of the document

significant part was changed to better accommodate all the functions and needs that could ever be demanded from this board. Program used to create both the design and later the printed circuit board was EasyEDA [26].

Output regulation

Very low drop voltage regulator (LDO) was chosen for output regulation. This choice was done with careful consideration of requirements for this device. The output is required to be controllable and in a voltage range for IoT devices. These devices require input voltages ranging from 3,3 V to 5 V. In basically all cases it is either 3,3 V or 5 V. Any other requirements would be highly unusual and

were not considered as essential for this device. Because of the nature of applications subject of this thesis will be used in, it will almost always be set up for a specific controller (this board will be optimized for ESP32 as said before) and therefor will not need any output regulation after setup. This and the

significantly lower price of materials were strong enough reason to use a fixed voltage regulator LF33CDT-TR [22]. This regulator will ensure that least amount of power will be lost in the process of conversion and yet the output will be protected. As all the regulators have the same size, another version can easily be soldered to fit any specific needs. Because of using one specific product family the circuit setup is the same for all the LDOs and thus making sure the output is adjustable (circuit can be seen below on figure 5). Output voltages of this product family can be: 1,5; 1,8; 2,5; 3,3; 4,7; 5; 6; 8; 8,5; 9; 12 V while only voltages of up to 6 V are viable for this build, a simple resistor R2 and R3 (figure 4) swap in the divider on V_{FB} of LT3652 [20] can increase the set battery charging voltage, so after that only different batteries and higher voltage solar panels would be needed. This

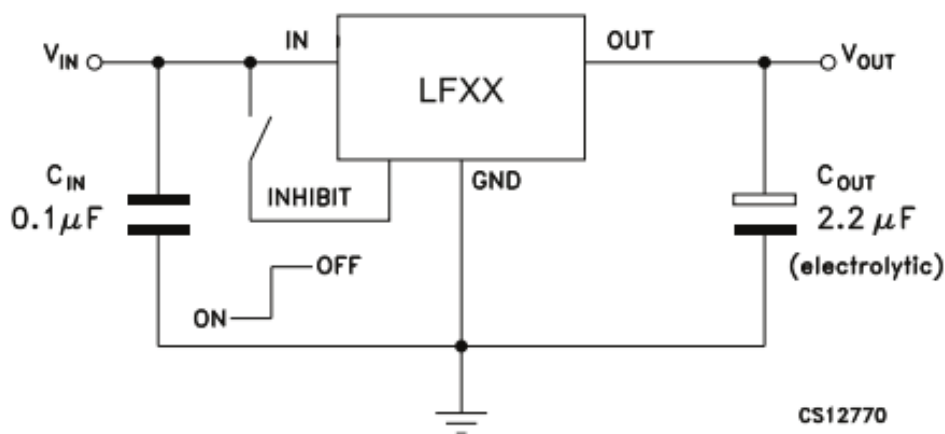

Figure 7: LDO circuit setup, inhibit function is not supported in used LDO [22]

of course is only theoretical and will not be part of any further text or measurements. In conclusion for each type of application a suitable LDO can be chosen and used. In this exact build it was decided to set the output voltage to 3,3 V as the controller requires that exact amount. It would be possible to set it all the way up to 5 V because of the controllers onboard LDO [22], it would however decrease efficiency of the whole setup.

LT3652

This power management unit was chosen as a part of the building blocks of the whole device. It allows up to 2 A of current to flow through at 36 V. This is plenty enough for low power controller and thus allowing for a power reserve. Additionally, this unit comes at a form-factor of 4x5 mm so it saves a lot of room on the board, thanks to its ability to provide power management for both battery

and solar cells. The chip builds upon the strengths of Linear Technology's widely used LT3650 family of battery chargers. It is essentially a monolithic buck battery charger IC for modern battery chemistries. The device includes an innovative input voltage regulation loop which controls charge current to hold the input voltage at a programmed level. When the LT3652 is connected to a solar panel, the input regulation loop forces the panel to operate at peak output power. This input voltage regulation loop circuitry delivers virtually the same optimized output power as more complex and expensive MPPT techniques. All in all, it extracts the maximum available power from the solar panel, reduces charge current if the panel output voltage falls below a programmed level, maintains the panel at the output voltage corresponding to the peak output power point for the particular solar panel being used, and makes it possible to program the specific desired peak-power voltage via a resistor divider [23].

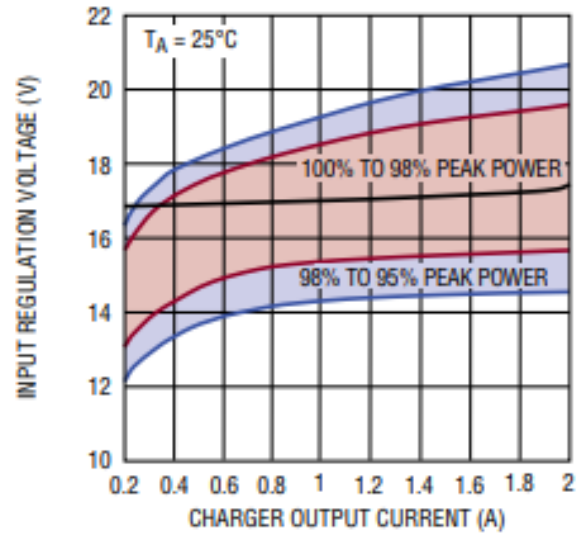

Figure 8: Voltage regulation diagram [20]

Pin 8 from component layout was not used considering this device's nature and the fact, it is going to be encased in a casing already equipped with a ventilation system to make sure the batteries do not overheat. In this case it was decided against using this function for budget purposes. Resistor R1 is a potentiometer with overall resistance of 500 kOhm and is used to set input voltage regulation loop and enable peak power tracking function. The divider created by grounding one of the potentiometer pads creates a divider and with only use of a screwdriver point for ideal power output can be set. This will increase the efficiency of the power harvesting part of the board to up to 98% [20]. Detailed description of this device's abilities can be found in previous chapter Function blocks.

P1, P2 pins

These are binary outputs of LT3652 [20] and can be used to light up small indication diodes, however that would be unnecessary on a board that is going to be enclosed in a plastic box most of its lifetime. Instead these outputs were used as a possible binary input for controller that may carry either a flag signal (that the batteries are dead, or that the sun is not shining) so the controller can react accordingly or simply as another measurable input in case of charge indication. This will provide the controller with useful information on how long the sun has been hitting the panel and

possibly be a good source for statistics concerning this area. Additionally, the battery fault indication is very useful for maintenance and will help to not lose any crucial data.

Chassis

On the image bellow an image of chassis made for this device can be seen. It was decided to keep it flat instead implementing a roof-like part, since it would only make the device bigger and the ideal angle can change from application to application, so it was ultimately left up to the user to set the device up in any position and angle necessary. The housing object was designed in a way to make the device as resilient as possible and with no glue applied (except of course for the solar panels on the top), it should also be rainproof. If enough glue is applied, the whole chassis can be made waterproof, however it would significantly impact number of sensors, that could be present in the chassis itself and make potential repairs or check much more difficult. Rain proofing was especially important in making of this project, because as mentioned many times before, versatility is one of the main goals and thanks to rainproof design, this requirement will be met. There are different ways to integrate both ESP32 which this project was based around along with various sensors. Sensors like ambient pressure sensor and solar panel current or voltage meters can be left in the chassis, however in direct sunlight temperature sensor would not show reliable information, so holes to connect peripheral sensors were added. The holes should also work as a cooling mechanism for the casing. Note that it is important to add some kind of net or a grid to prevent living organisms from entering the object and potentially damaging the electronics. The holes themselves might seem useless, because they take away from devices protentional complete waterproofing, however throughout the summer temperatures might rise high enough to damage or destroy included accumulators. This could not be tested, but it is author's strong belief that the risks included are not worth taking. The closing mechanism is simple and can be seen on the image bellow. It is essentially an angled connection of top and bottom half which should prevent any water from getting in. Pins can be used as a closing mechanism. On the top panels will need to be glued in a careful way to ensure, no water will get inside. There are holes for each wire soldered to the panel. These wires will then be connected straight to the board. The overall structure is held together firmly enough by the tight connection between the two halves. These will lock into place once the setup is ready and the halves are pushed against each other and can be opened afterwards just as easily thanks to slightly flexible plastic that can be used. Overall this design should allow for most outdoor applications while retaining simplistic features and securing board's safeties along with battery overheating protection and non-intrusive look in case it would be placed in line of sight. Renders of the chassis can be seen below on figures (9, 10).

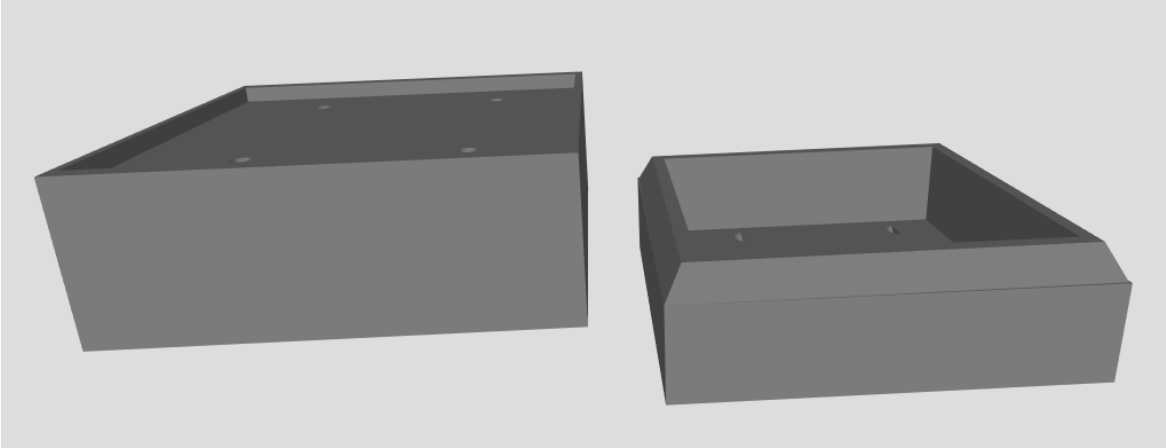

Figure 9: Top view of the chassis

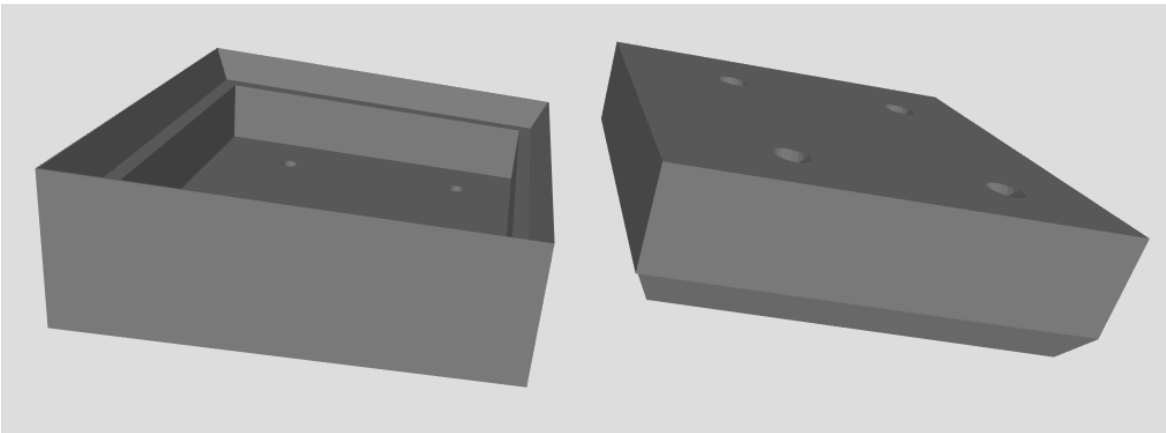

Figure 10: Bottom view of the chassis

Printed Circuit Board

This chapter will discuss the board layout and general decision-making concerning the printed circuit board (PCB). The most ergonomic and future-proof layout possible was chosen and therefore this board was designed with SMT technology. Surface-mount technology replaces the "through-hole technology," wherein components are mounted by linking up "leads" inserted into circuit board holes to pads on the opposite side of the board. Through-hole technology was used throughout the 1950s and into the 1980s until SMT started gaining popularity. Some advantages of SMT include the ability to create smaller components, higher component density and greater efficiency in assembly, since fewer holes need to be drilled in the circuit board. SMT also provides better presentation of the structure of circuit boards, which allows easy examination of the placement of components because they are surface mounted rather than connected to the soldered holes [24]. Thanks to this technology the whole board can be easy enough to operate on for a beginner whilst being shrunk down to 6x4 cm.

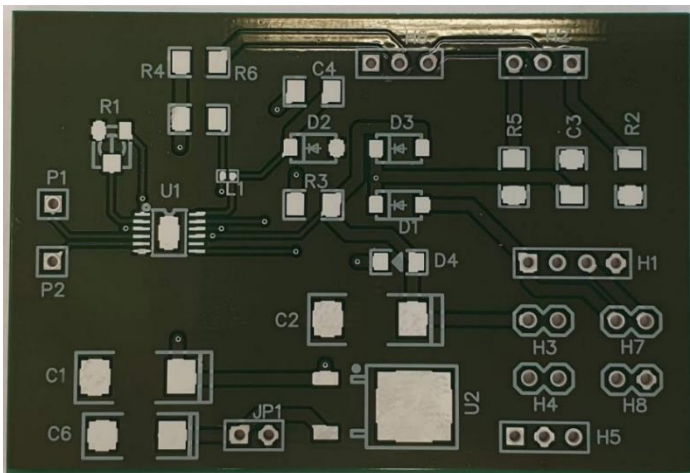
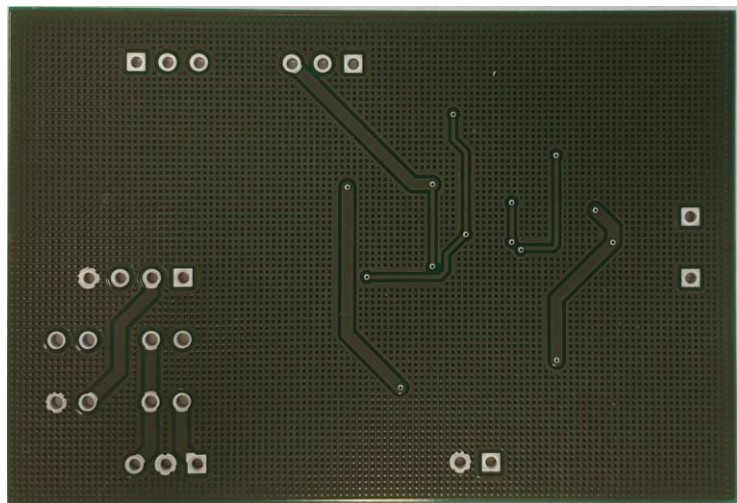

Figure 11, 12: Top layer of the board to the left and bottom layer of the board to underneath



This might not seem like much, but with point soldering even gaps like the ones present on this board are challenging enough. Top and bottom layers can be seen without any components on figures (11, 12) above.

It is noteworthy that most components are in 1206 casing to unify the boards look and to not confuse anyone building this board. Additionally, the whole of top layer was set to be ground, which was made by placing a copper foil and galvanically separating wired connections with 1 mm width, which should ensure smooth transfer of power. Right bottom corner is board input (87, H8). This was made to make sure that the connections transferring more power are as short as possible, therefor saving some power and prolonging board's lifespan. Right next to the inputs on the bottom there is LDO and capacitors. Right after H7, H8 there is H1, which is a simple switch that allows to change serial or parallel combination of panel with a simple pin jumper and same goes for H5 but with batteries and slightly modified switch.

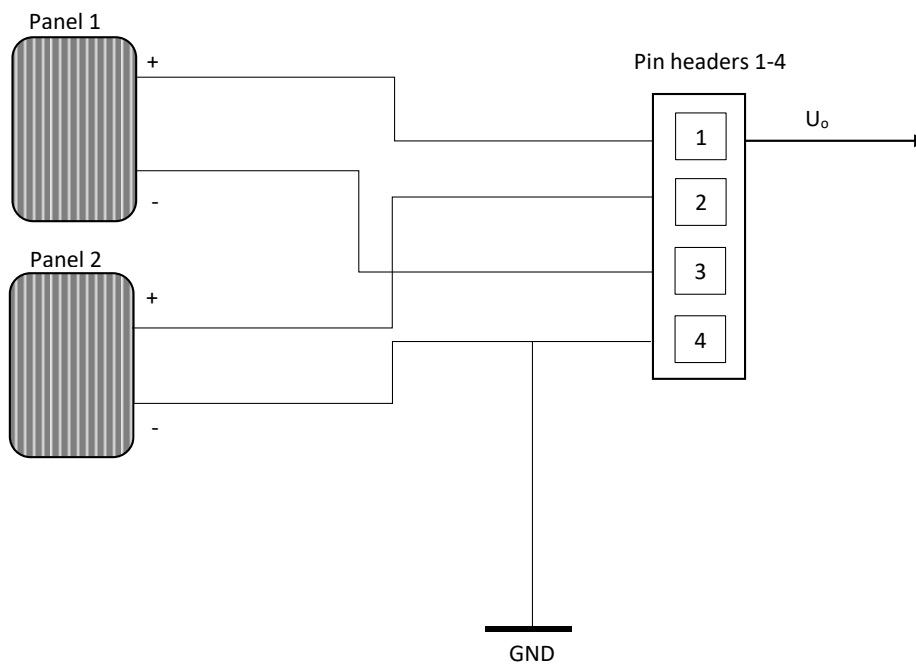

Figure 13: Panel serial/parallel switching with jumpers

D1 is a Schottky diode to protect circuit from wrong input polarity. Schottky diode was chosen for its low drop in voltage. D3 is also a Schottky diode and was also chosen for its small drop in voltage characteristic. It protects batteries from being damaged by unregulated voltage produced by solar panels. Output voltage is stabilized by electrolytic capacitor C6. Top left quadrant is power management and necessary parts. R1 is a variable resistor (trimmer) which allows the user to set

MPPT [20] to any value necessary to make sure the panels are loaded by the LT3652 in a way that drains the most power from the panels. H2 and H6 pins are switches that regulate the battery voltage. For 7,2 V batteries, H2 is set to 470 kOhm and H6 to 280 kOhm (pins 1 and 2) and 3,6 V is set be the other position of the jumper. The resistance necessary was calculated from [20]:

$$R2 = \frac{(V_{BAT(FLT)} \cdot 2,5 \cdot 10^5)}{3,3},$$

$$R3 = \frac{R3 \cdot 2,5 \cdot 10^5}{R3 - (2,5 \cdot 10^5)}.$$

Equation 1: Battery voltage setting equation

On the schematic R5 and R6 are variants of R2 and R3 for 3,6 V as a set battery voltage. The logic of the circuit still works the same, but it was added as an option to make sure, that solar panels in parallel connection can be used. On the backside couple connections that did not fit on the front side were added. The rest of the space was also used as grounding pad with grid fill style.

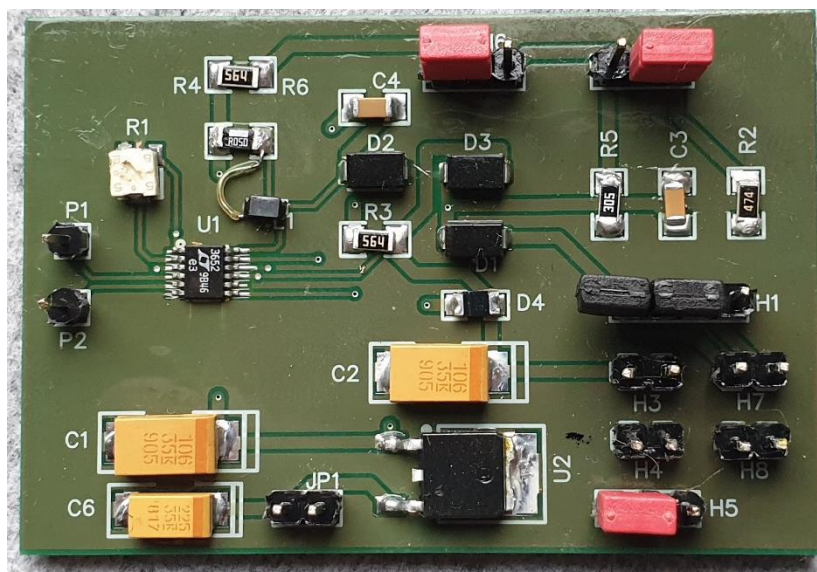

Figure 14: PCB already with parts on, the uneven spread of plastic protective layer caused the distortions in top-right corner. Coil pads were too close due to an error in board design, hence the wire above U1.

Measurements

Measurements have been separately for both solar panels and the device the rest of the board. This was done to improve on accuracy thanks to using a laboratory power source.

Measuring the panels

Panels were left under ideal angle outside and both voltage and current without any load were measured on the short circuit, in serial combination. Day of measurement: May 16. 2019, weather conditions: Partly cloudy before 1 pm and cloudy afterwards

Table 1: Solar panels measurement

Time	Voltage [V]	Current [mA]
11:00	11,0	91
11:30	11,1	8
12:00	11,3	10
12:30	11,0	91
13:00	11,1	92
13:30	11,2	5
14:00	11,1	4

Sudden drops in current can be seen as the clouds covered the sun, voltage level remains approximately the same.

Measuring controller

The controller was measured in different modes to make sure final results would be accurate as it is switching between the modes every 20 minutes, when the measurements are supposed to be taken.

Table 2: Device power requirements

device drainage:	
On mode, trying to connect to wifi:	126 mA
On mode, not trying to connect	60 mA
Sleep mode	0,5 mA

The measured current was at 3,3 V after the conversion in LDO regulator. As is obvious from the table, device requires a lot of power when in on mode. That fortunately only happens for 10 seconds every 20 minutes.

Measuring the board

Board was measured while connected to laboratory power source for maximum accuracy. Both batteries were connected to the board. Battery voltage was measured every 10 minutes with different input settings.

Table 3: Charging batteries as they would in a sunny day

Constant current $I = 90\text{mA}$ and voltage $U = 11\text{V}$	
Time (minutes)	Battery Voltage [V]
0	3,57
10	3,62
20	3,71
30	3,78
40	3,83

Table 4: Charging batteries as they would during a cloudy day

Constant current $I = 10\text{mA}$ and voltage $U = 11\text{V}$	
Time (minutes)	Battery Voltage [V]
0	3,57
10	3,58
20	3,59
30	3,59
40	3,60

The batteries start charging at input level of 3,3 V above the set voltage of batteries. This will be achieved as long, as it is day, since the solar panels will always output something above 5,5 V each but with less light give less current.

Energy balance

This chapter will discuss whether the device will be autonomous or whether the power demand will be higher than the panels can supply. Average amount of hours of sunlight in Prague, Czech Republic is 1573 per year [27] this would mean the overall input would be $1573 \cdot 91$ mAh, but efficiency has to be taken in account. Even though both chips used should offer something about 90% and above, for safety reasons 50% will be considered. The LT3652 additionally consumes up to 2,5 mAh and the LDO regulator up to 1,5 mAh, these make 96 mAh over course of a day (these values will not be as high in reality but need to be accounted for). The controller as measured before will consume 0,5 mAh most of the time and every 20 minutes this value will increase to 124 mAh for 10 seconds, this averages to 1,5 mAh per hour and 36 mAh per day. So, in conclusion per day 132 mAh is lost. With average input of 143,1 Ah per year divided into 365 days and reduced by 50% efficiency for a big enough power reserve input equals 196 mAh per day. This number is calculated counting sun hours only. Some power should be harvested even when it is cloudy, even though it would be minimal, it should at least be enough to power the board and the device in sleep mode. These numbers obviously reflect ideal conditions and consider average day and temperature. During winter sun hours average all the way down to 43 per month, this would be too low for the device and a lot of power would be drained from batteries, which would have their capacity reduced due to low temperatures and the device could very well lose all forms of power supply. This could be prevented up to a point by isolating the batteries and possibly measuring voltage of batteries to get a notification when they drop dangerously low.

Battery charging data were not used as the measurement was done mainly as a way to find out if the device works as supposed to. The method of calculating balance by counting average sun hours is more accurate since the data are more complex and offer more reliable information.

Future improvements

One thing that sticks out from the power balance is that the board takes almost 3 times as much power as the device itself. That is caused by both chips onboard being designed for higher power inputs and slightly different uses, than low power IoT applications. The board was designed in such a way that with only few changes these higher power functions could be implemented, or different setup could be used when harvesting energy or charging batteries which increased the versatility of the board but added unwanted elements and pins to the board. That should be changed for future iterations and only low power parts and chips should be used as well as a single purpose setup. The LT3652 was chosen as a building block of this device, but Linear Technology offers low-power chips for uses exactly as this thesis was aimed for. Most interesting iteration would be adding RF-based charging to the low powered chip mentioned above, which could create a natural signal barrier for certain types of signals in housing complexes and offer power for IoT sensors.

Furthermore, the board would have different input/output mechanisms than pin headers. Those proved to be difficult to work with. Than some holes should be added as holding points for the device. The board could also be shrunk down to about half the size and use smaller casings to allow that.

This device was created to be as cheap as possible, however that proved to be difficult when buying electrical components at lower quantities. If thousand would be made the price for single board would drop to acceptable enough range, however this would not be true for prototypes.

Conclusion

Research researched power sources optimized for IoT applications. This was used as a foundation for drafting and prototyping this device's parameters. Afterwards analysis of efficiency of various renewable power sources was made. This analysis was focused at those sources that would best fit low power IoT applications

Prototype of a board was drafted in a way it could be powered from renewable sources and energy could be stored in accumulators, which would power the device when needed. This board was designed to supply power to ESP32 controller, which was used as an IoT node. Additionally, binary output pins were added to signal operation and battery states to the controller.

Functional prototype was created and tested. The test data were used along with statistical information to create an energy balance study. The device seems to be able to maintain its autonomous functionality for most of the year, however winter might prove to have too few sun hours to effectively maintain the autonomy.

References

- [1] Stankovic, J.A. Research Directions for the Internet of Things. IEEE IoT J. 2014, 1, 3–9. [Accessed 16 April 2019]
- [2]. M. Prauzek, P. Musilek and A. G. Watts, "Fuzzy algorithm for intelligent wireless sensors with solar harvesting," 2014 IEEE Symposium on Intelligent Embedded Systems (IES), Orlando, FL, 2014, pp. 1-7. [Accessed 16 April 2019]
- [3] M. Prauzek, J. Konecny, M. Borova, K. Janosova, J. Hlavica and P. Musilek, "Energy Harvesting Sources, Storage Devices and System Topologies for Environmental Wireless Sensor Networks: A Review", Sensors, vol. 18, no. 8, p. 2446, 2018. Available: 10.3390/s18082446 [Accessed 23 May 2019].
- [5] F. Shaikh and S. Zeadally, "Energy harvesting in wireless sensor networks: A comprehensive review", Renewable and Sustainable Energy Reviews, vol. 55, pp. 1041-1054, 2016. Available: 10.1016/j.rser.2015.11.010 [Accessed 12 April 2019].
- [6] V. Raghunathan, A. Kansal, J. Hsu, J. Friedman, and M. Srivastava. 2005. Design considerations for solar energy harvesting wireless embedded systems. In Proceedings of the 4th international symposium on Information processing in sensor networks (IPSN '05). IEEE Press, Piscataway, NJ, USA, Article 64. [Accessed 16 April 2019]
- [7] V. Aggarwal, "Solar Panel Efficiency: What Panels Are Most Efficient? | EnergySage", Solar News, 2019. [Online]. Available: <https://news.energysage.com/what-are-the-most-efficient-solar-panels-on-the-market/>. [Accessed: 03- Apr- 2019]. [8] Gul, M., Kotak, Y., & Muneer, T. (2016). Review on recent trend of solar photovoltaic technology. Energy Exploration & Exploitation, 34(4),
- [9] R. Krishnamurthy, "Charting The Sun's Motion In Relation To Your Home And Permaculture Site - The Permaculture Research Institute", The Permaculture Research Institute, 2019. [Online]. Available: <https://permaculturenews.org/2015/10/23/charting-the-suns-motion-in-relation-to-your-home-and-permaculture-site/>. [Accessed: 08- Apr- 2019].
- [10] H. Ostaffe, "RF-based Wireless Charging and Energy Harvesting", Cz.mouser.com. [Online]. Available: https://cz.mouser.com/applications/rf_energy_harvesting/. [Accessed: 11- Apr- 2019].
- [12] J. Gabay, "RF Energy Harvesting: Batteries Not Included", Digikey.com, 2015. [Online]. Available: <https://www.digikey.com/en/articles/techzone/2015/oct/rf-energy-harvesting-batteries-not-included>. [Accessed: 16- Apr- 2019]. [13] M. A. Kishk, H. S. Dhillon, "Modeling and analysis

of ambient RF energy harvesting in networks with secrecy guard zones", Proc. IEEE Wireless Commun. Netw. Conf. (WCNC), pp. 1-6, Mar. 2017.

[14] D. Carli, D. Brunelli, D. Bertozzi and L. Benini, "A high-efficiency wind-flow energy harvester using micro turbine," SPEEDAM 2010, Pisa, 2010, pp. 778-783. doi: 10.1109/SPEEDAM.2010.5542121 [Accessed 16 April 2019]

[15] G. Mahan and J. Sofo, "The best thermoelectric.", Proceedings of the National Academy of Sciences, vol. 93, no. 15, pp. 7436-7439, 1996. Available: 10.1073/pnas.93.15.7436 [Accessed 16 April 2019].

[16] G. Snyder and E. Toberer, "Complex thermoelectric materials", Nature Materials, vol. 7, no. 2, pp. 105-114, 2008. Available: 10.1038/nmat2090 [Accessed 9 April 2019].

[17] Y. K. Tan and S. K. Panda, "Optimized Wind Energy Harvesting System Using Resistance Emulator and Active Rectifier for Wireless Sensor Nodes," in IEEE Transactions on Power Electronics, vol. 26, no. 1, pp. 38-50, Jan. 2011. doi: 10.1109/TPEL.2010.2056700 [Accessed 9 April 2019].

[18] M. Dowling, Mark Costello. (2018) Feasibility Study of Embedded Wind Energy Harvesting System for Parafoil-Payload Aircraft. Journal of Aircraft 55:5, 2127-2136. Online publication date: 1-Sep-2018.

[19] M. Alhawari, B. Mohammad, H. Saleh, M. Ismail, "A survey of thermal energy harvesting techniques and interface circuitry", Electronics Circuits and Systems (ICECS) 2013 IEEE 20th International Conference on, pp. 381-384, 2013.

[20] Analog Devices, "Power Tracking 2A Battery Charger for Solar Power," CA 95035-7417 datasheet, 2010

[21] STMicroelectronics, "Very low drop voltage regulator with inhibit function," DocID2574 Rev 31 datasheet, 2017

[22] Espressif Systems, "ESP32 Series," datasheet, 2016, last revision April 2019

[23] S. Knoth, "Simpler Route to Solar Charging", Power Electronics, 2009. [Online]. Available: <https://www.powerelectronics.com/alternative-energy/simpler-route-solar-charging>. [Accessed: 12-Mar- 2019].

[24] "What is Surface-Mount Technology (SMT)? - Definition from Techopedia", Techopedia.com. [Online]. Available: <https://www.techopedia.com/definition/2304/surface-mount-technology-smt>. [Accessed: 07- Apr- 2019].

[25] L. Columbus, "The Era Of Integrated IoT Has Arrived In The Enterprise", Forbes.com, 2019. [Online]. Available: <https://www.forbes.com/sites/louiscolumbus/2017/09/29/the-era-of-integrated-iot-has-arrived-in-the-enterprise/#4a34cdf64bd2>. [Accessed: 16- May- 2019].

[26] "EasyEDA - Online PCB design & circuit simulator", Easyeda.com, 2019. [Online]. Available: <https://easyeda.com/>. [Accessed: 01- May- 2019].

[27] "TZB-info / Tabulky a výpočty / Průměrné měsíční doby slunečního svitu ve vybraných lokalitách ČR Průměrné měsíční doby slunečního svitu ve vybraných lokalitách ČR", TZB-info, 2019. [Online]. Available: <https://www.tzb-info.cz/tabulky-a-vypocty/99-prumerne-mesicni-doby-slunecniho-svitu-ve-vybranych-lokalitach-cr>. [Accessed: 17- May- 2019].

List of parts

Name/value	On board as	Footprint	Quantity	Manufacturer
10uF	C1,C2	CASE-E_7343	2	AVX
1u	C4	1206	1	AVX
10uH	L1	0402'	1	Ckmtw
LOAD	JP1	HDR-1X2/2.54	1	TE Connectivity
Z-211-0411-0021-001	H1	HDR-4X1/2.54	1	ZHENGLING
3M	R5	1206	1	RALEC
470K	R2	1206	1	LIZ
560K	R3,R6	1206	2	LIZ
BAT S/P	H2,H5,H6	HDR-3X1/2.54	3	ZHENGLING
0.05 Ohm	R4	1206	1	RALEC
BAT1	H3	7x3x3 cm	1	Ckmtw
BAT 2	H4	7x3x3 cm	1	Ckmtw
100n	C3	1206	1	AVX
LF33CDT-TR	U2	TO-252-2(2)	1	STMicroelectronics
Solar panel	H7	11x6x0,5 cm	1	Ckmtw
Solar panel	H8	11x6x0,5 cm	1	Ckmtw
LT3652IMSE	U1	MSOP-12EP	1	Analog Devices
Schottky diode	D1	SMA(DO-214AC)	1	Wolfspeed
Schottky diode	D2,D3	SMA(DO-214AC)	2	Wolfspeed
Header-Male-2.54_1x1	P1,P2	HDR-1X1/2.54	2	ReliaPro
CURN101-HF	D4	D1206	1	Infineon Technologies
2.2uF	C6	CASE-C_6032	1	KEMET
500K Ohm	R1	RES-ADJ_3313J-1	1	BOURNS

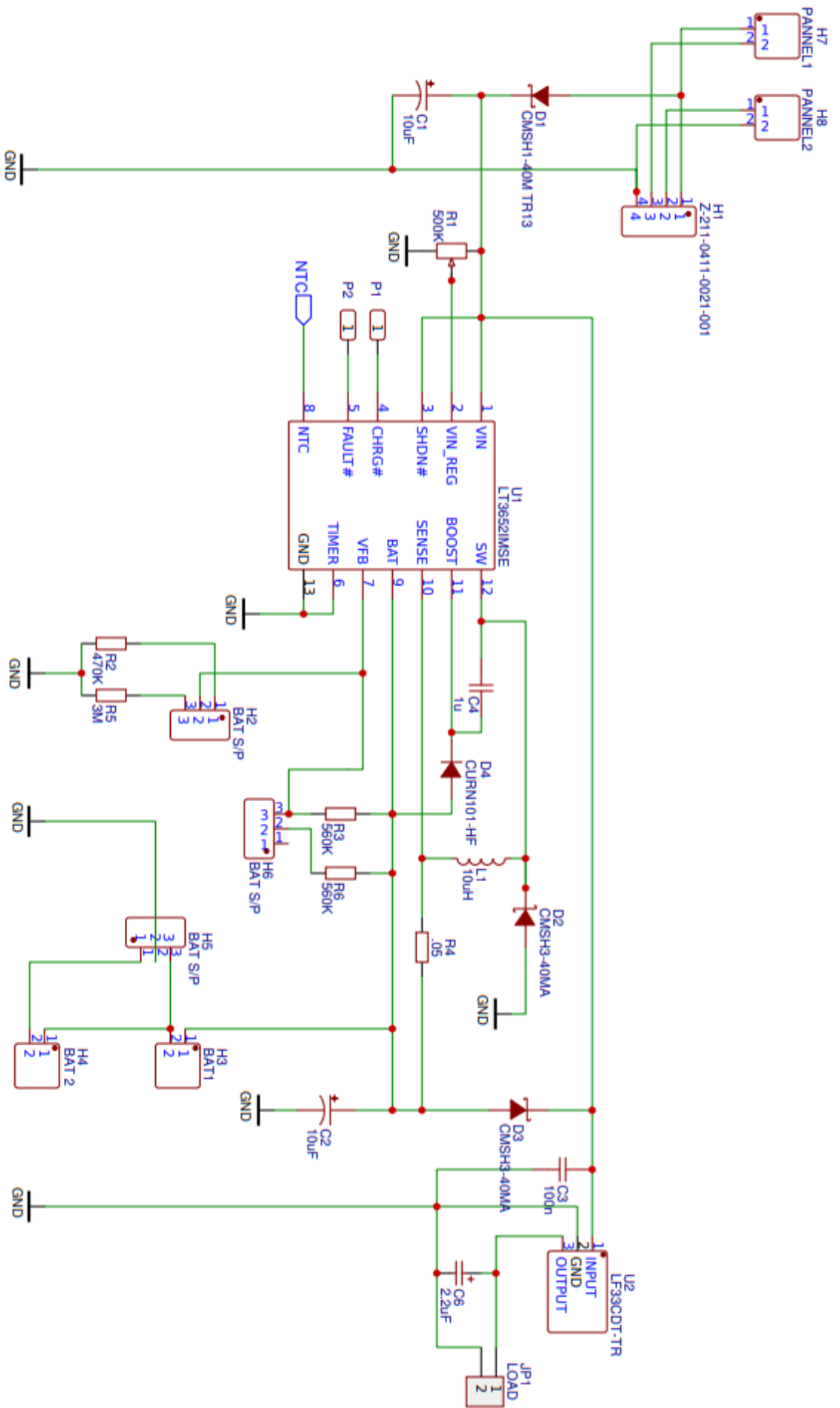

Figure 15: Magnified image of the board schematics

