



# C

## SO 101 - Komunikace a zpevněné plochy

|   |   |                                 |  |
|---|---|---------------------------------|--|
| NÁZEV DIPLOMOVÉ PRÁCE:<br><b>Rekonstrukce silnice<br/>II/501 Dolní Nová Ves - Lázně Bělohrad - Svatojanský Újezd</b>                        |   |                                 | <b>ČVUT</b><br>ČESKÉ VYSOKÉ<br>UČENÍ TECHNICKÉ<br>V PRAZE  |
| ČÍSLO PŘÍLOHY:<br><b>05.2</b>   | NÁZEV PŘÍLOHY:<br><b>Příčné řezy - II.etapa</b> | FORMÁT: 14xA4<br>MĚŘÍTKO: 1:200 |  |
| VEDOUCÍ DIPLOMOVÉ PRÁCE:<br><b>Ing. Petr Pánek, Ph.D.</b> , katedra silničních staveb, Fakulta stavební                                     |   |                                 | <b>Fakulta stavební ČVUT v Praze</b><br><br>Thákurova 7/2077<br>Praha 6 Dejvice<br>166 29<br> |
| VYPRACOVAL:<br><b>Bc. Michaela Jorová</b><br>01/2019<br> |   |                                 |  |



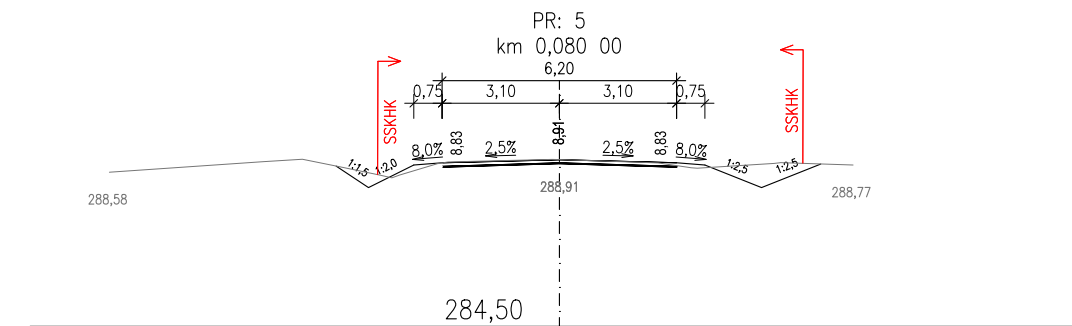
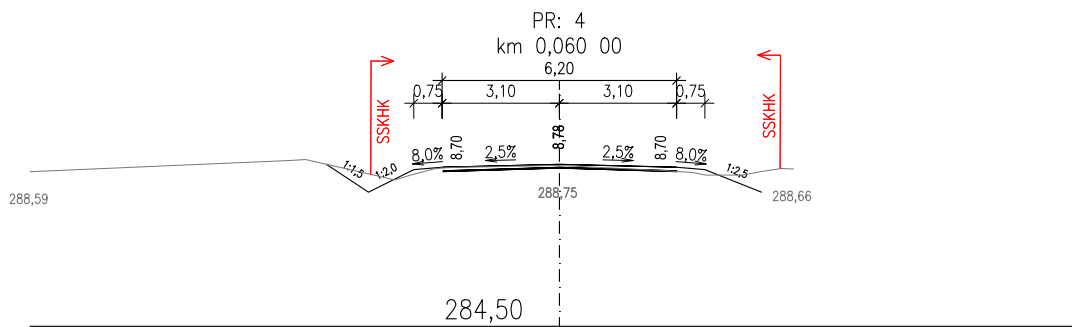
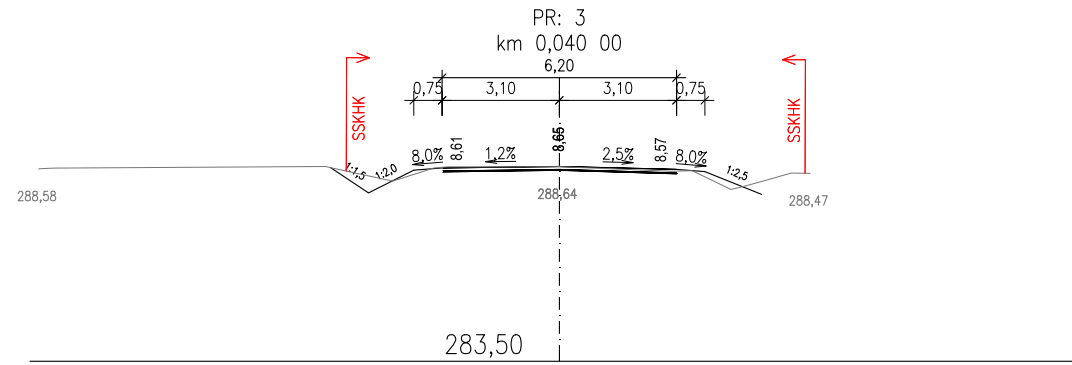
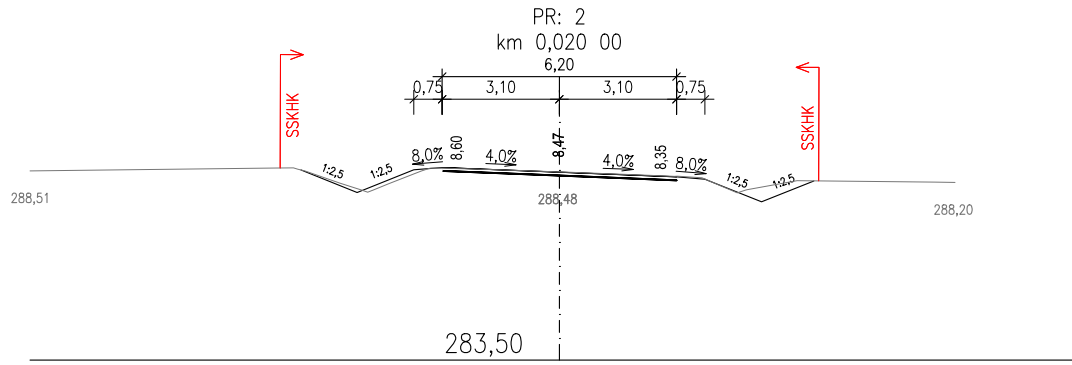
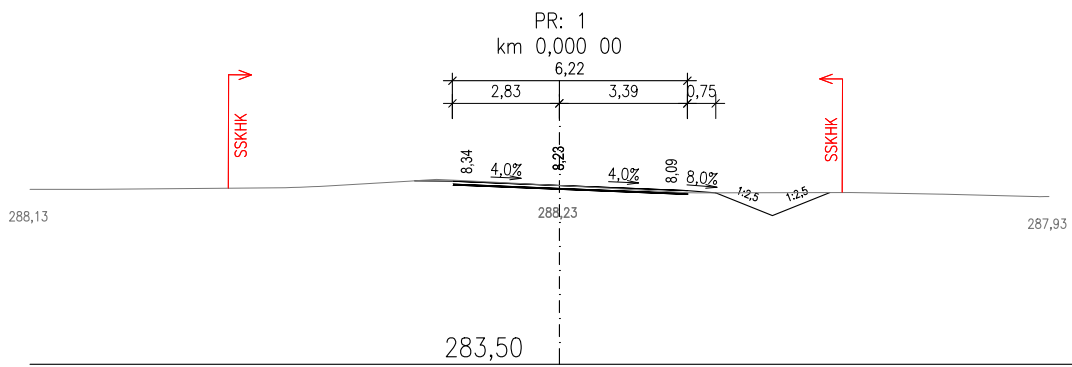
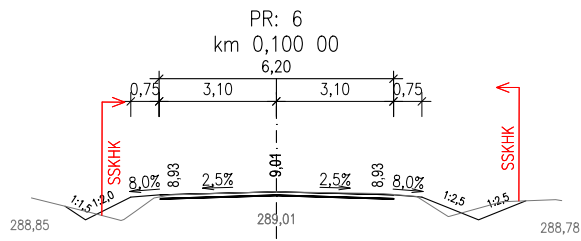

284,50

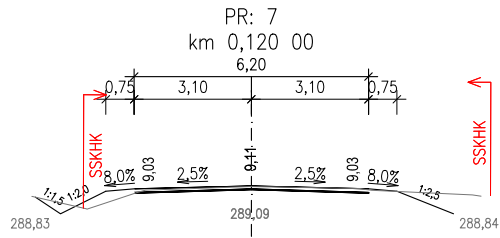

284,50

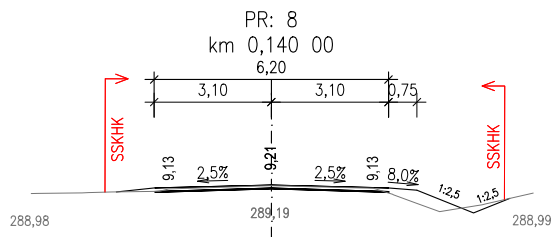

284,50

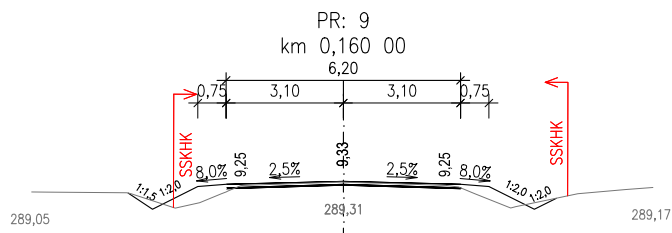

284,50

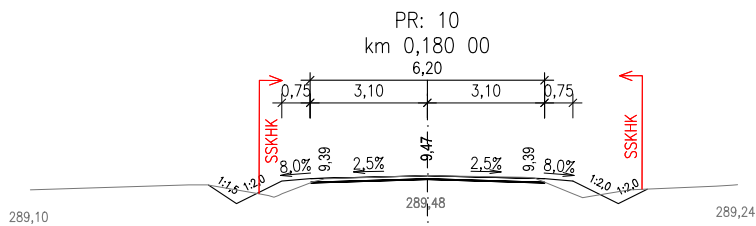

284,50

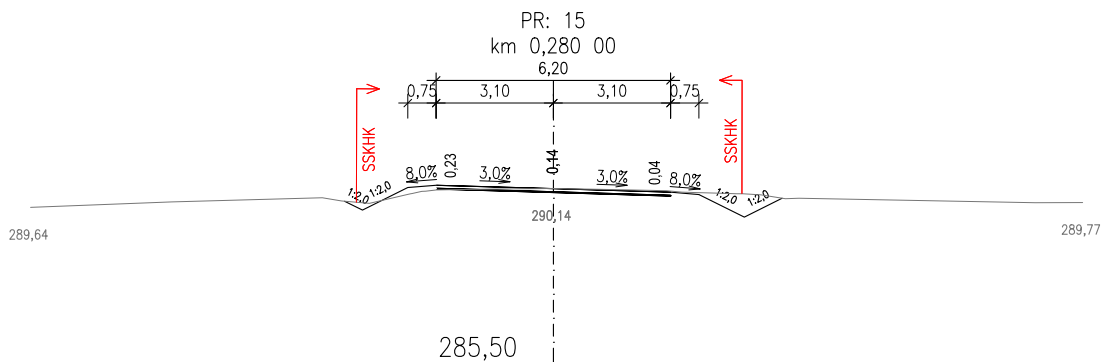
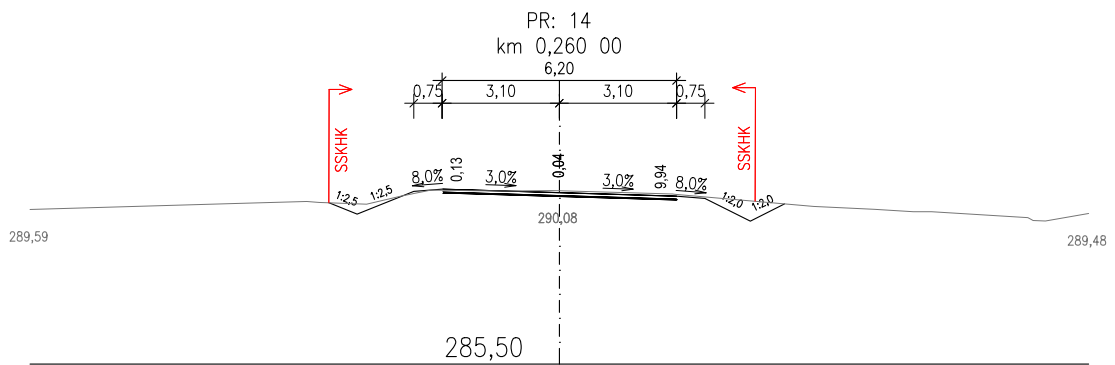
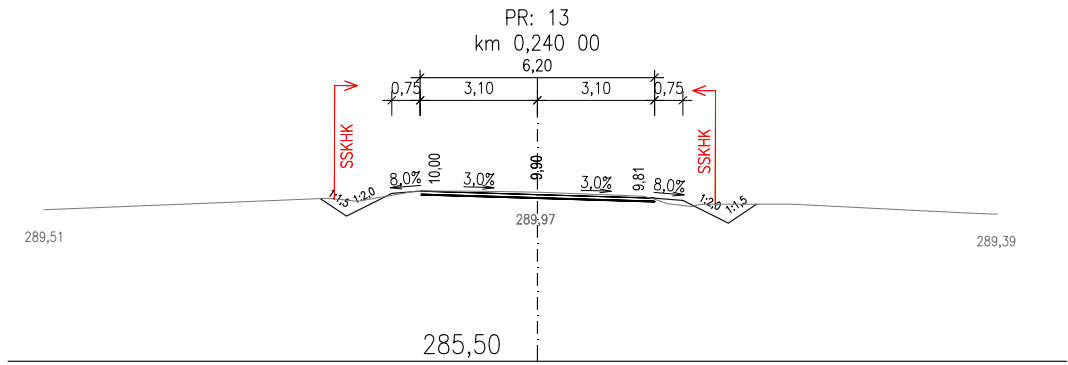
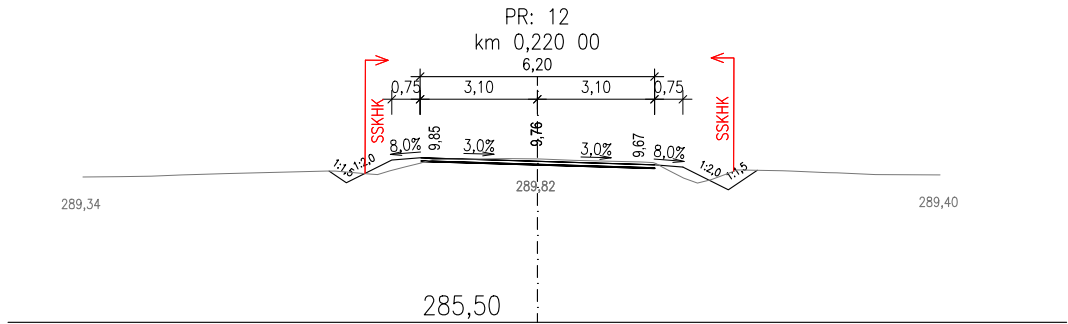
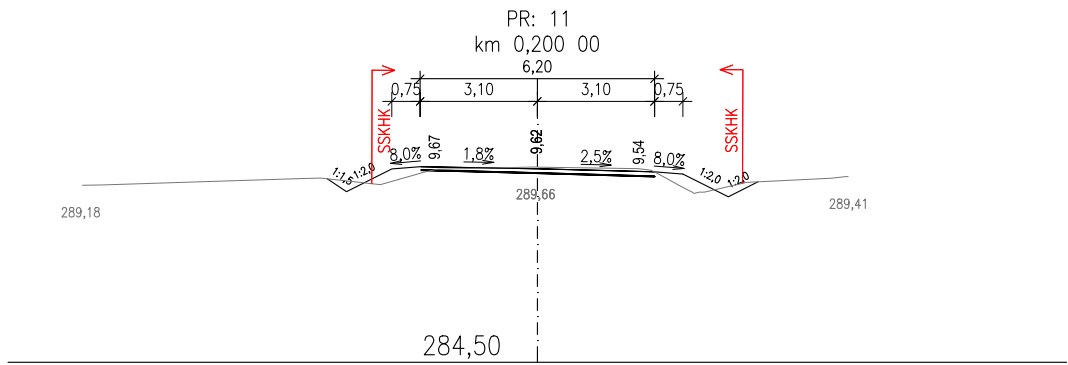

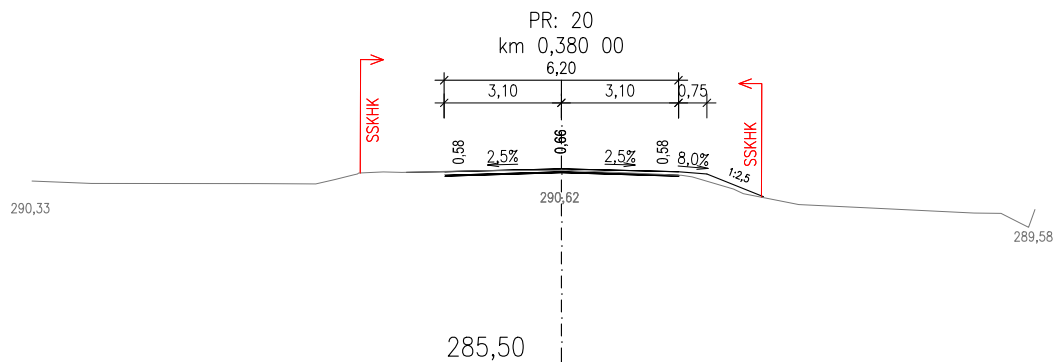
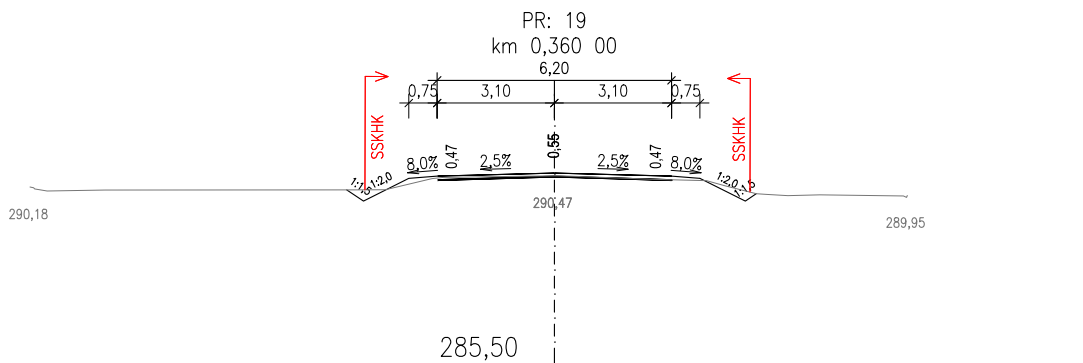
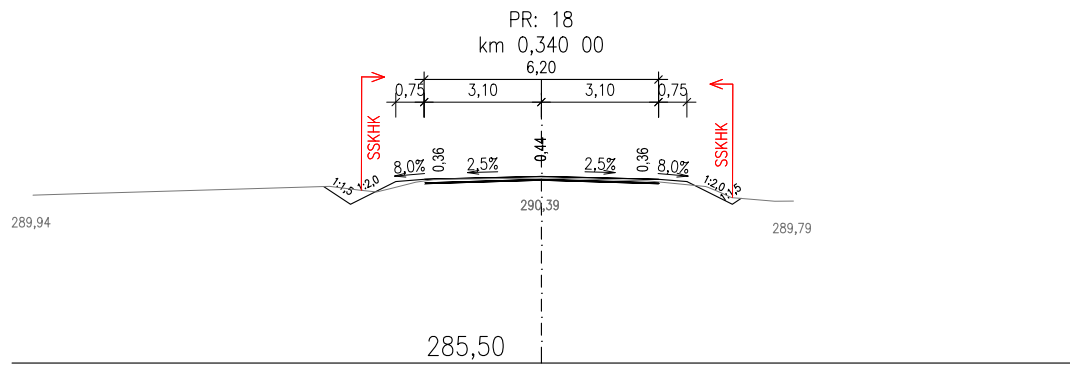
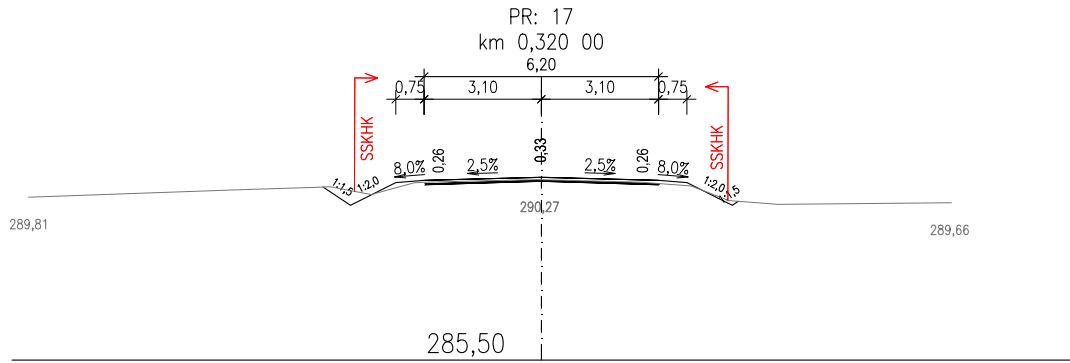
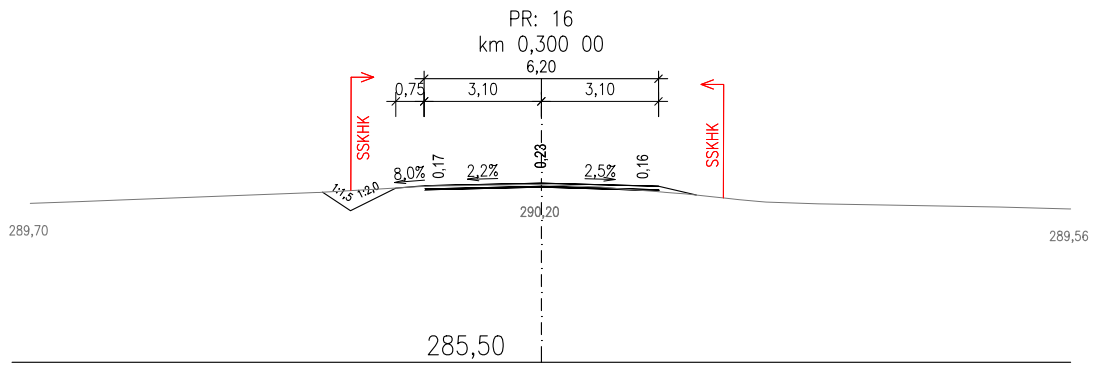

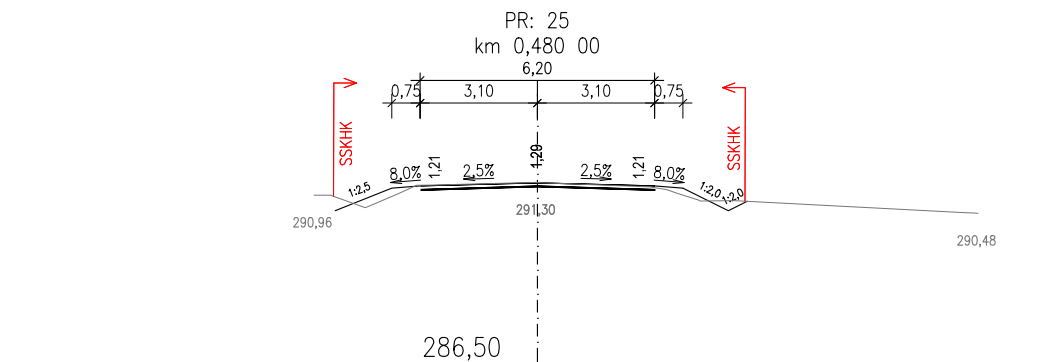
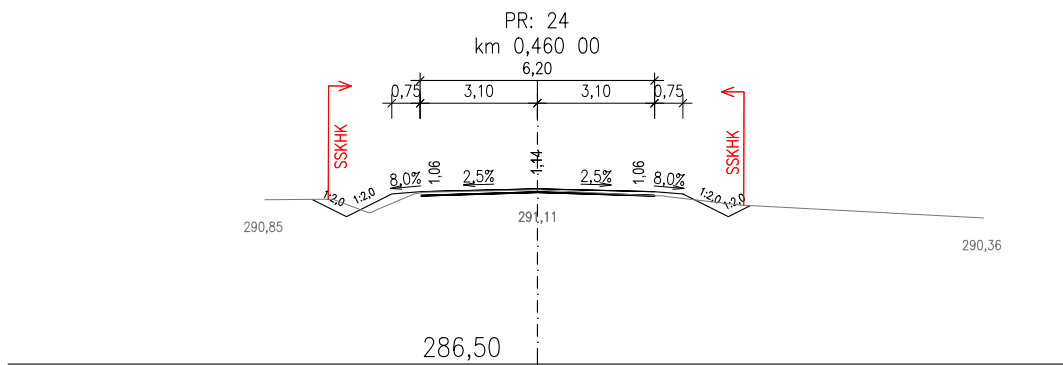
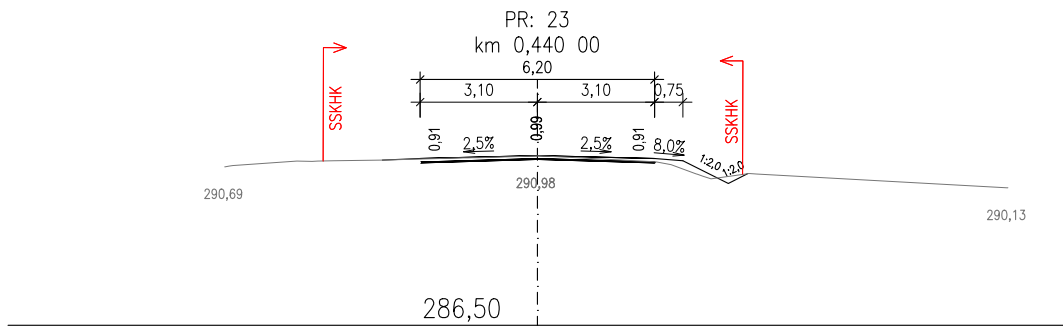
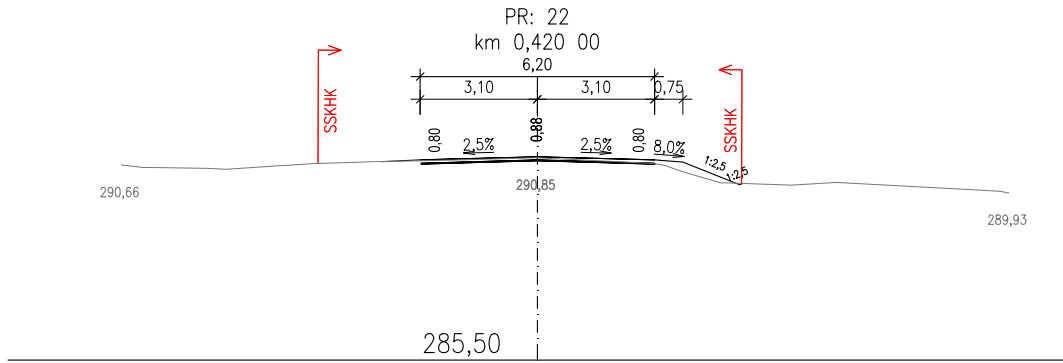
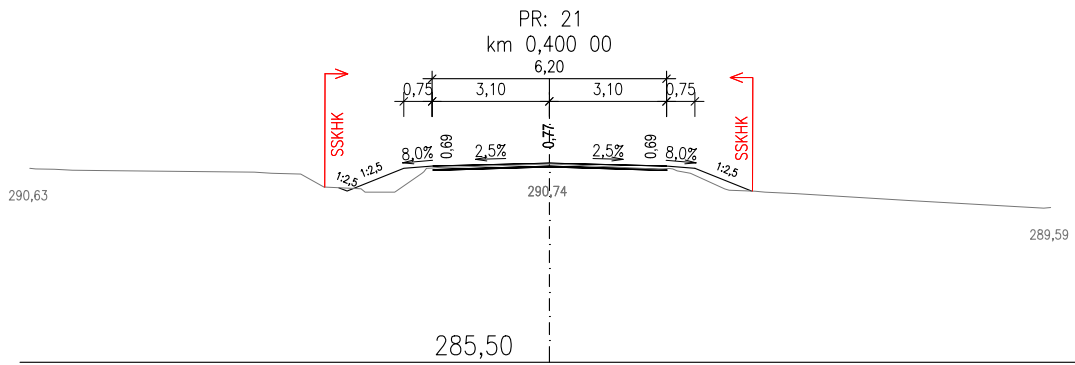

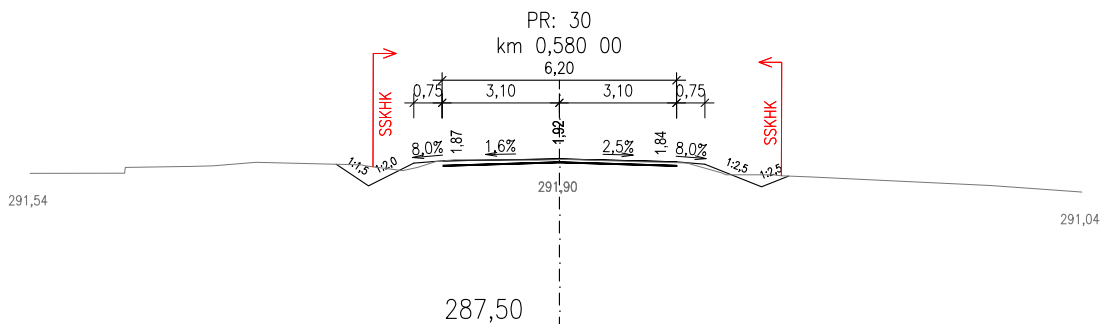
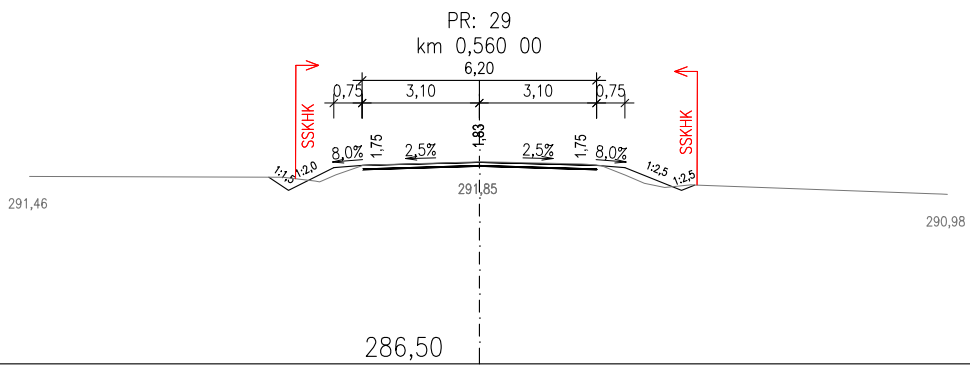
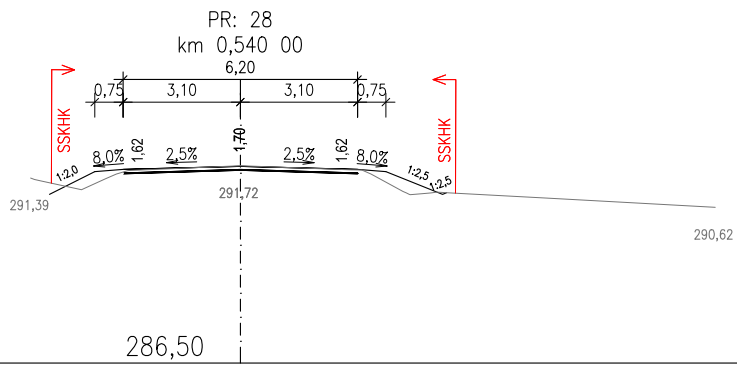
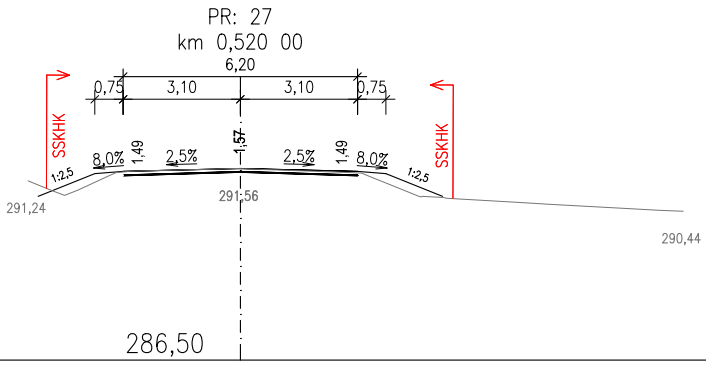
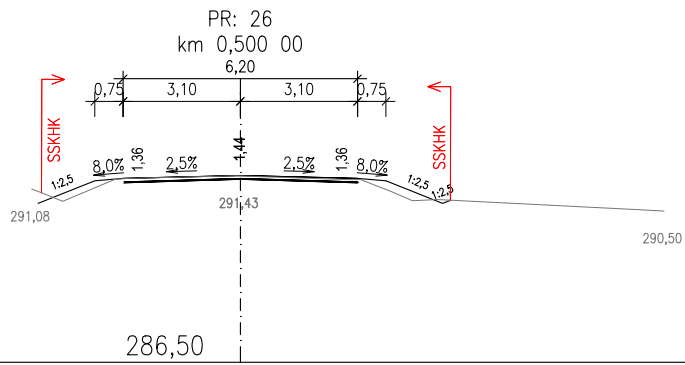

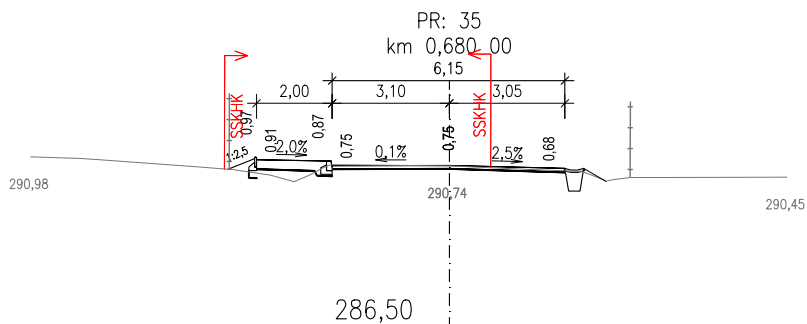
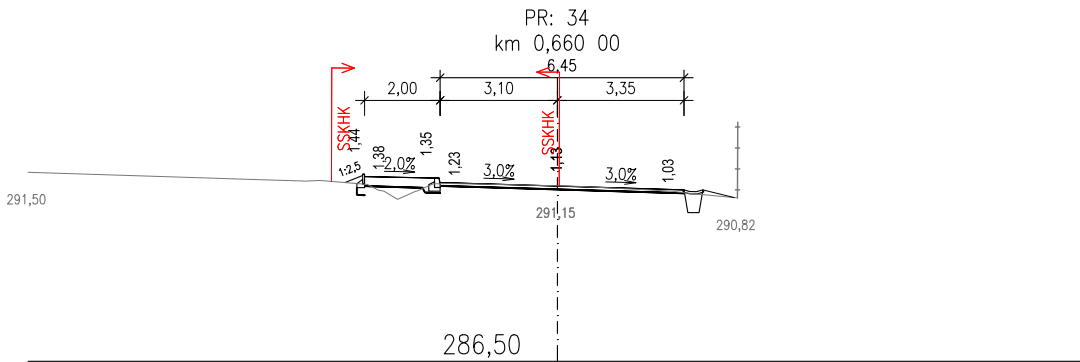
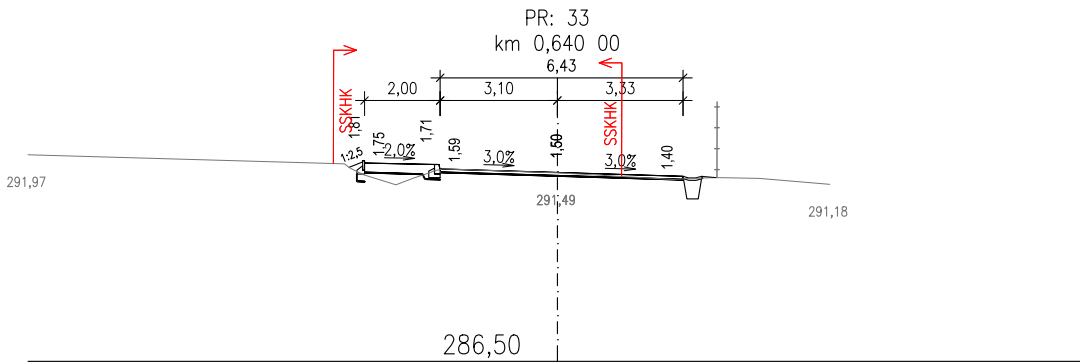
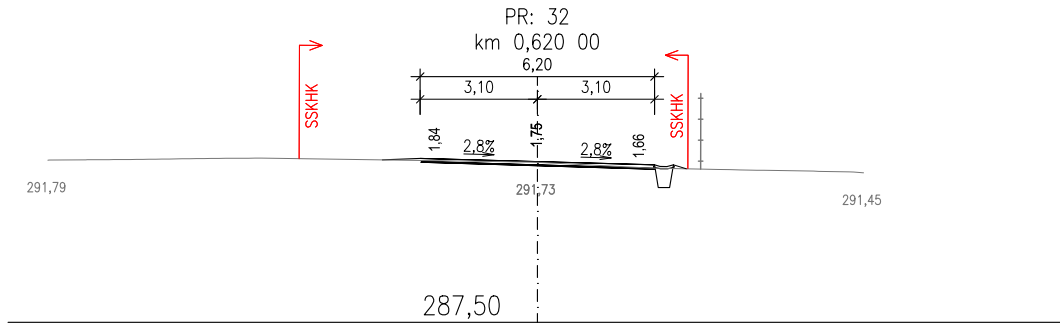
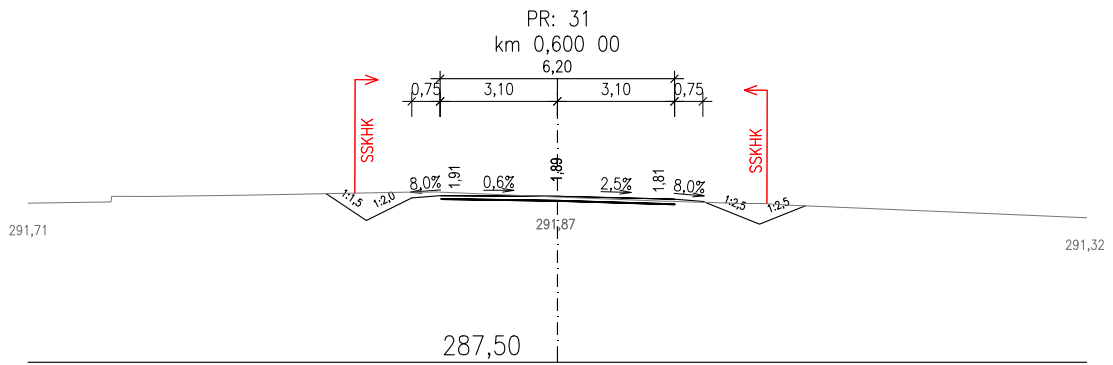



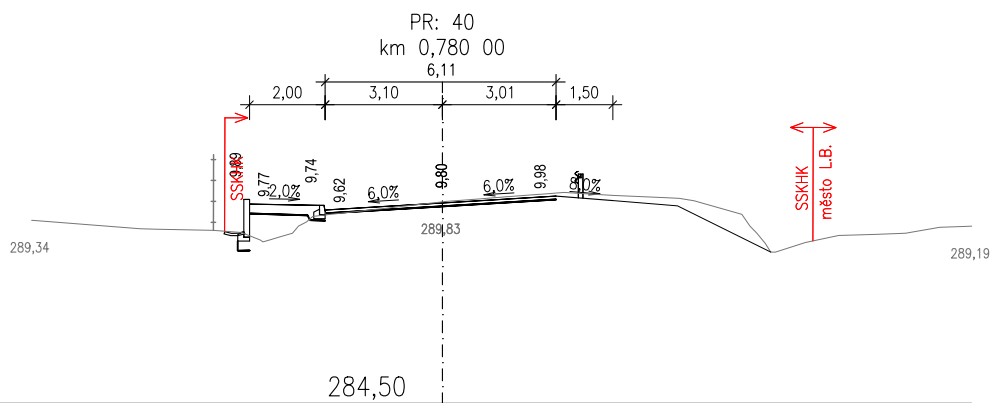
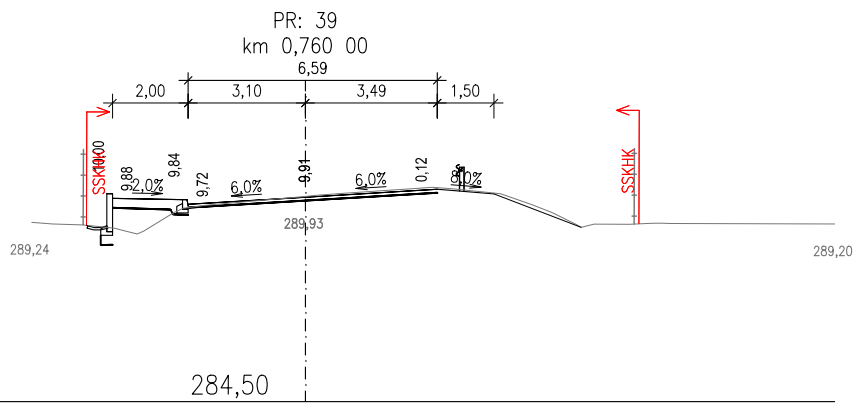
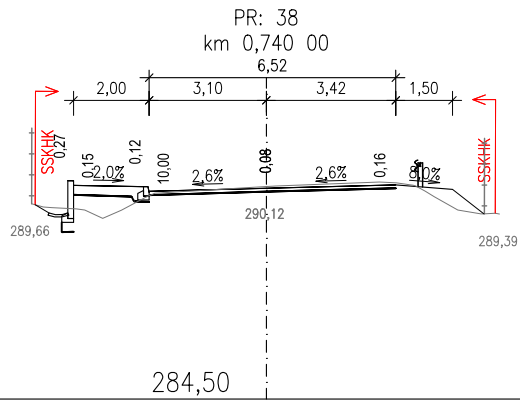
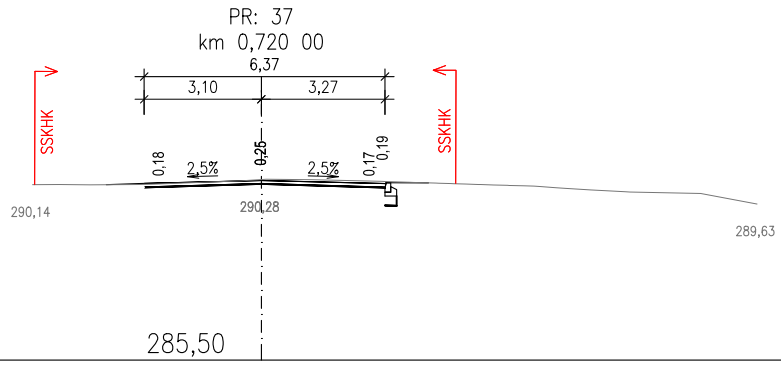
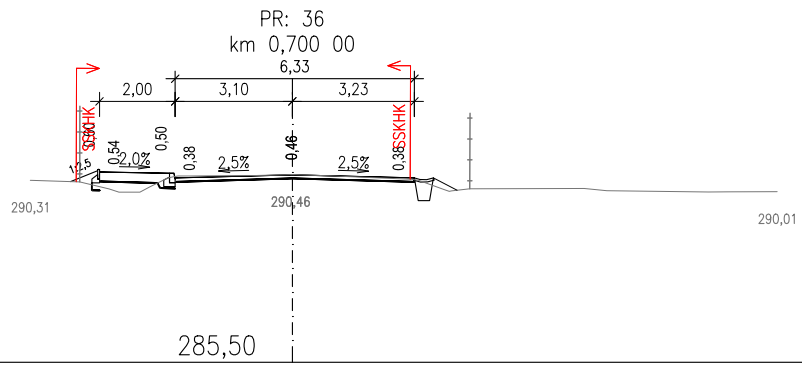

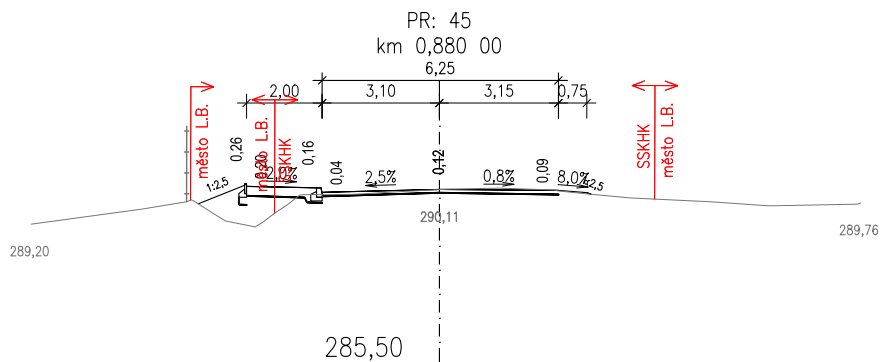
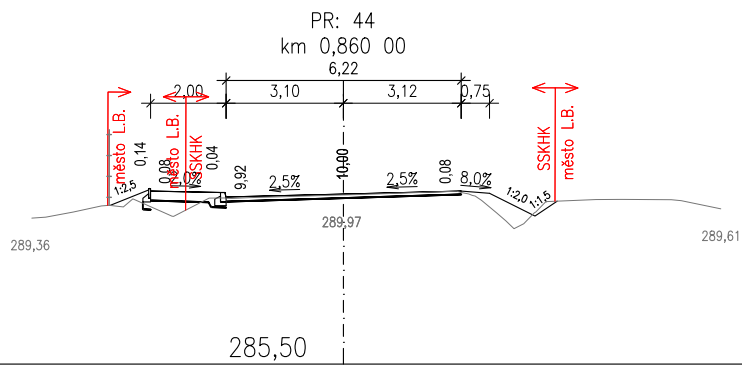
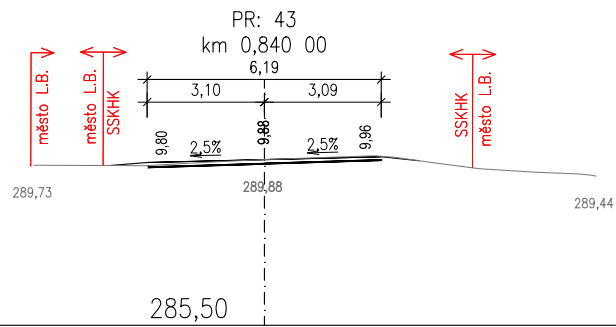
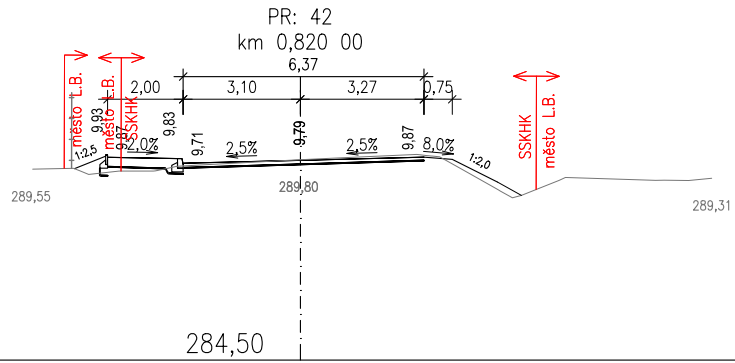
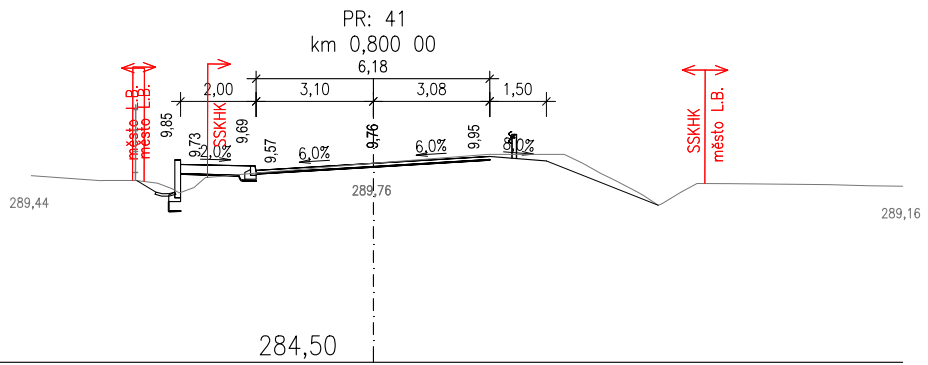

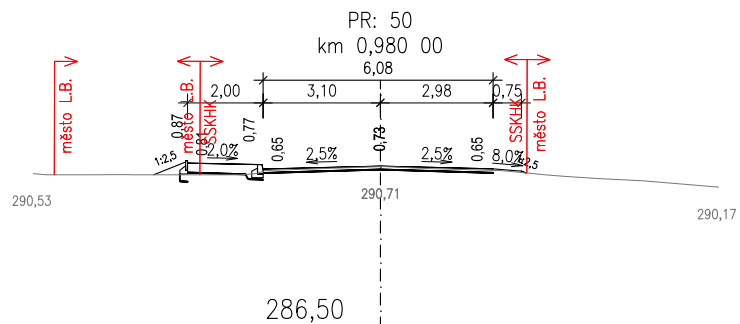
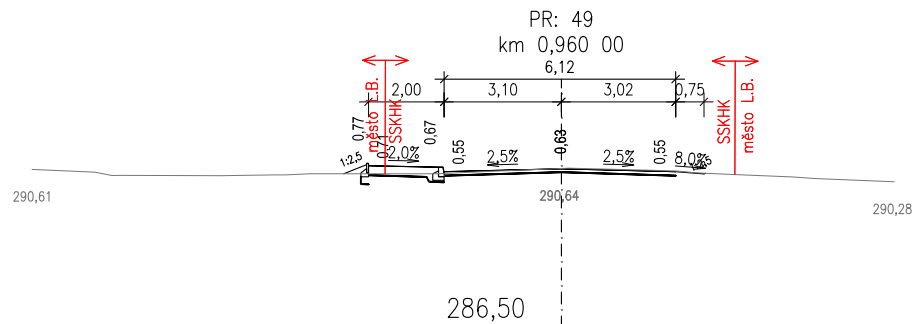
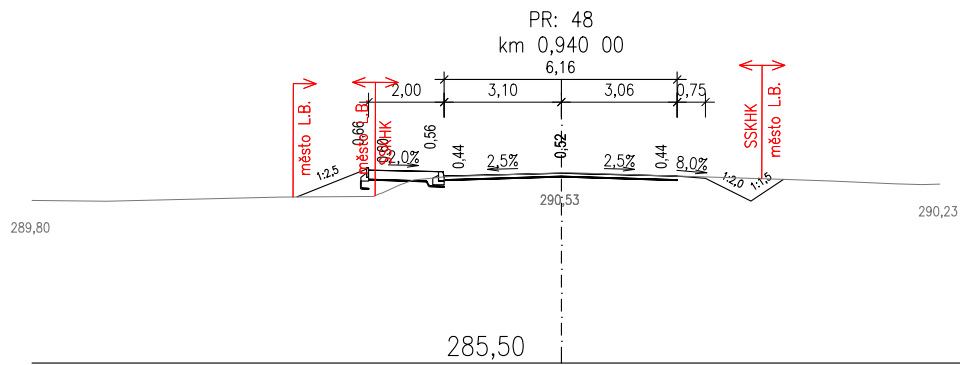
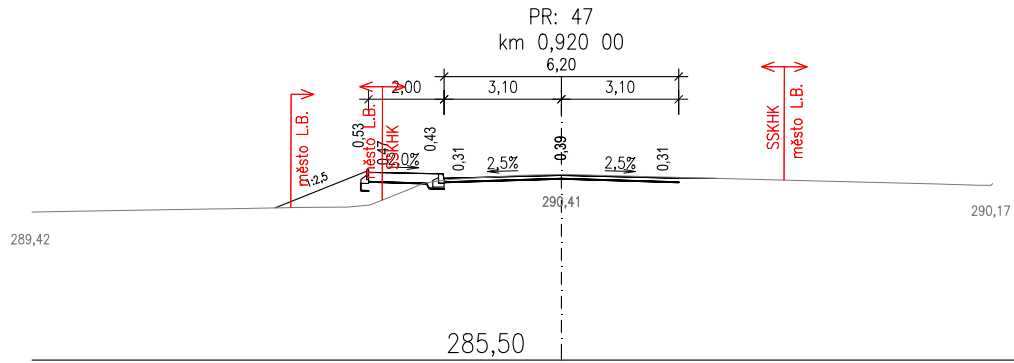
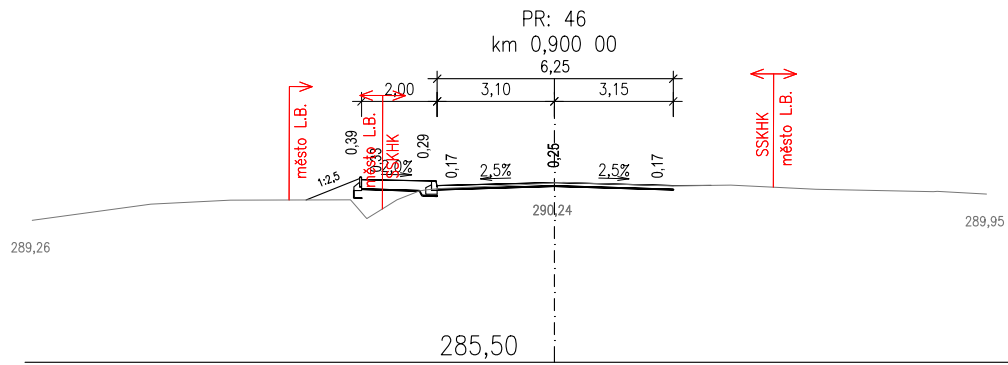

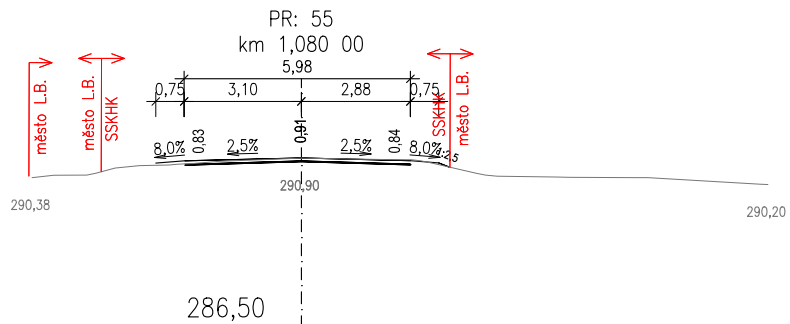
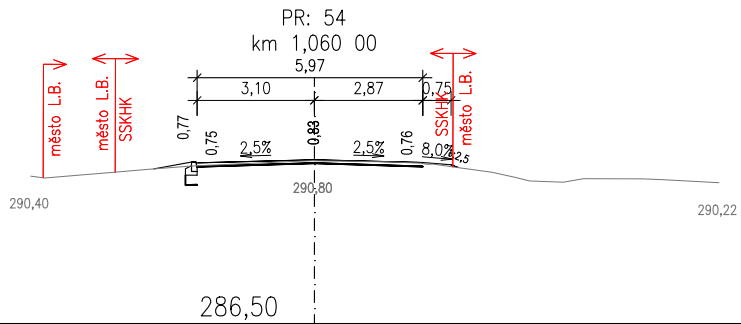
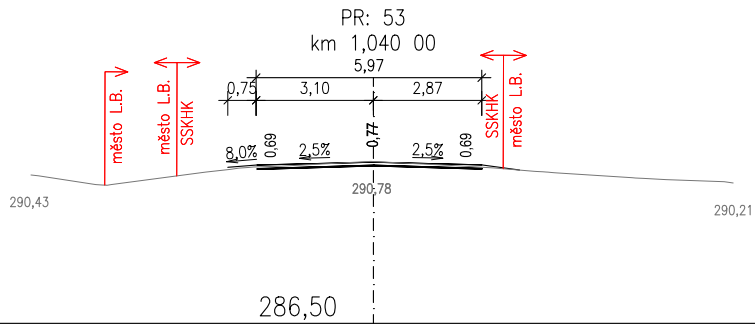
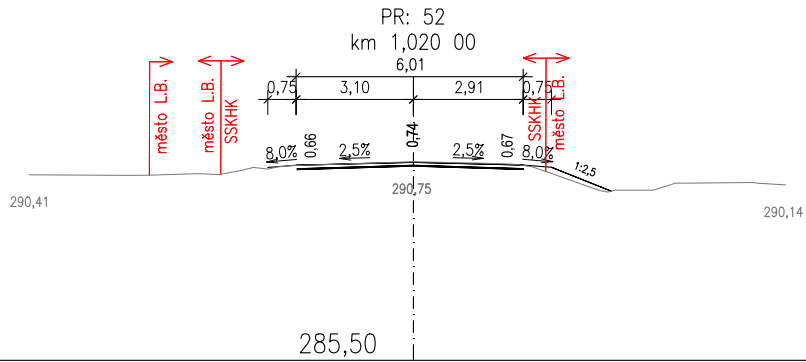
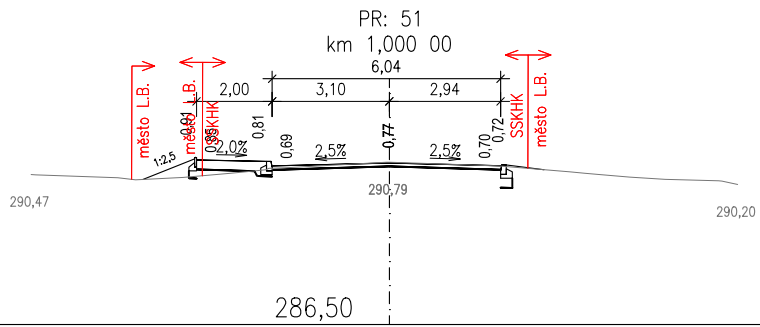

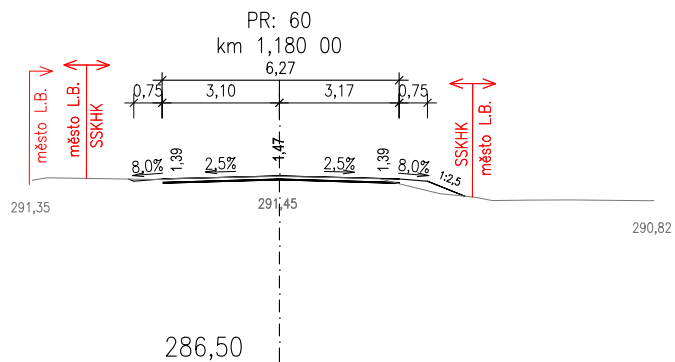
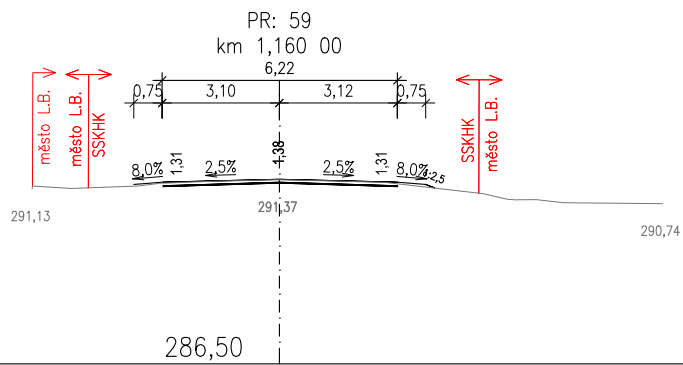
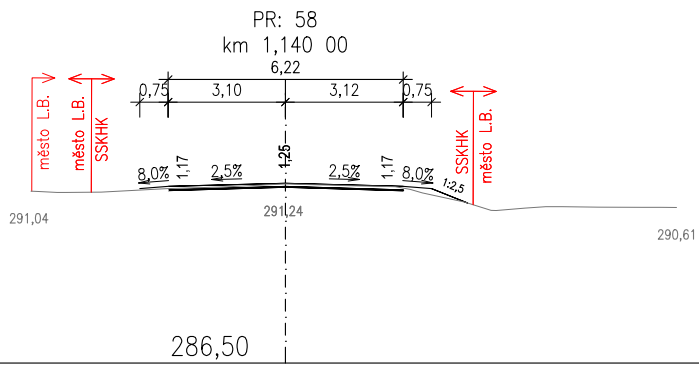
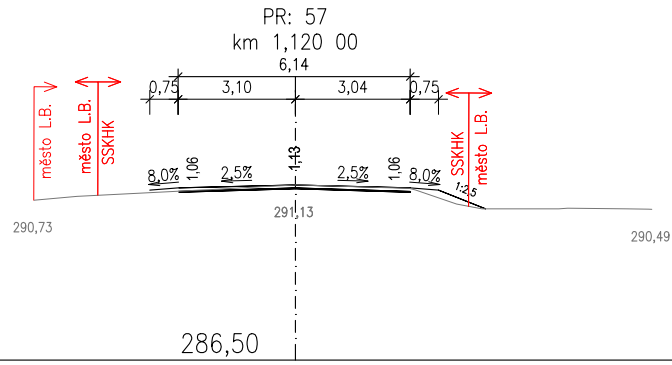
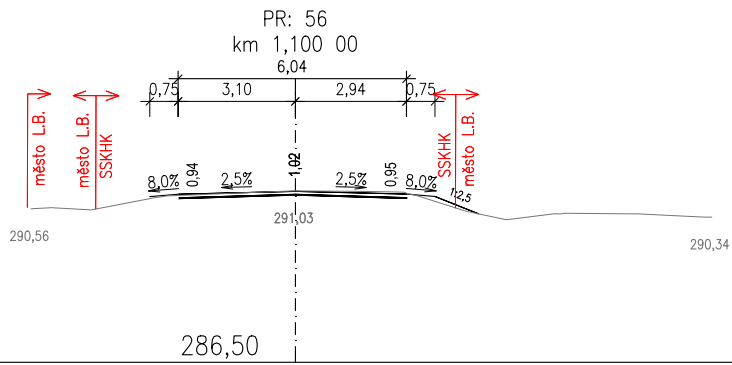

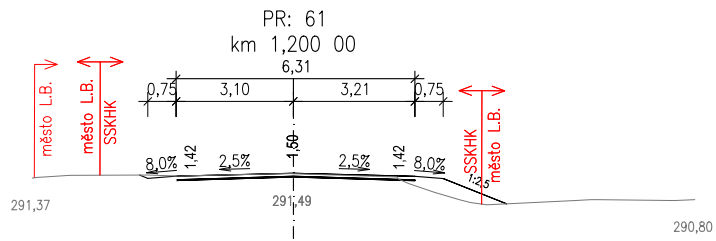

286,50

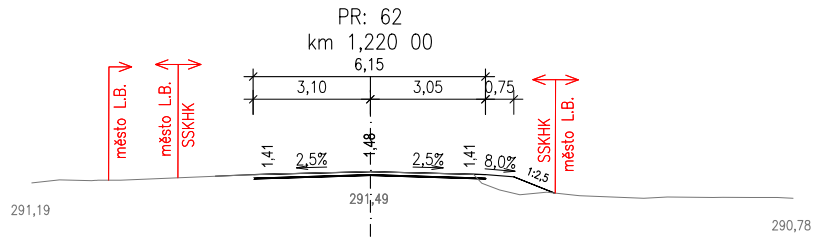

286,50

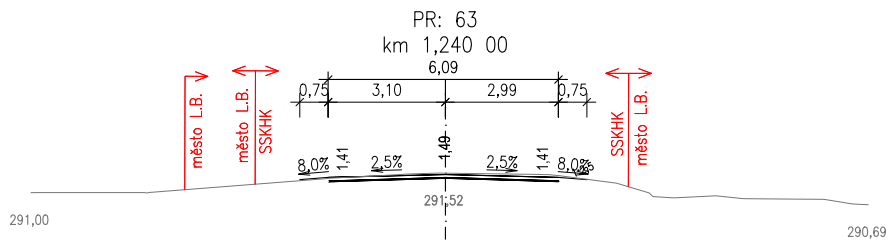

286,50

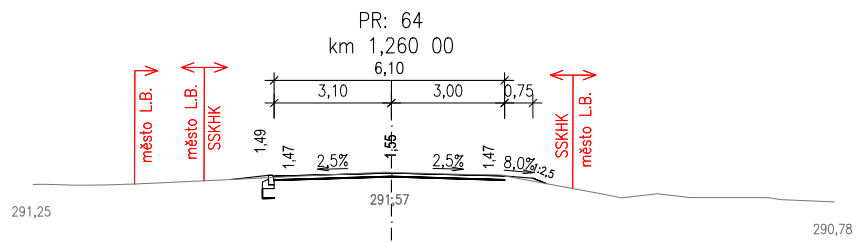

286,50

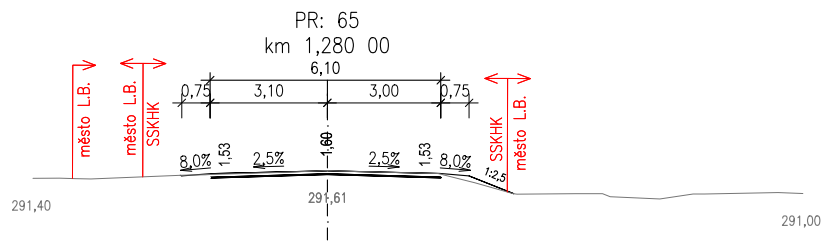

286,50

