

ZPRACOVALA:	VEDOUCÍ DP:	 FAKULTA STAVEBNÍ ČVUT V PRAZE
Ing. arch. Marcela Belov Váchová	Ing. Stanislav Frolík, Ph.D.	
PŘEDMĚT:	125DPM - Diplomová práce	
OBJEKT:	Administrativní objekt Na Knížecí	
VARIANTA:	PERSONALIZOVANÝ SYSTÉM VĚTRÁNÍ STANDARDNÍ SYSTÉM VĚTRÁNÍ	SEMESTR: ZS 2018/2019
NÁZEV:	TECHNICKÉ LISTY	ČÍSLO: 3

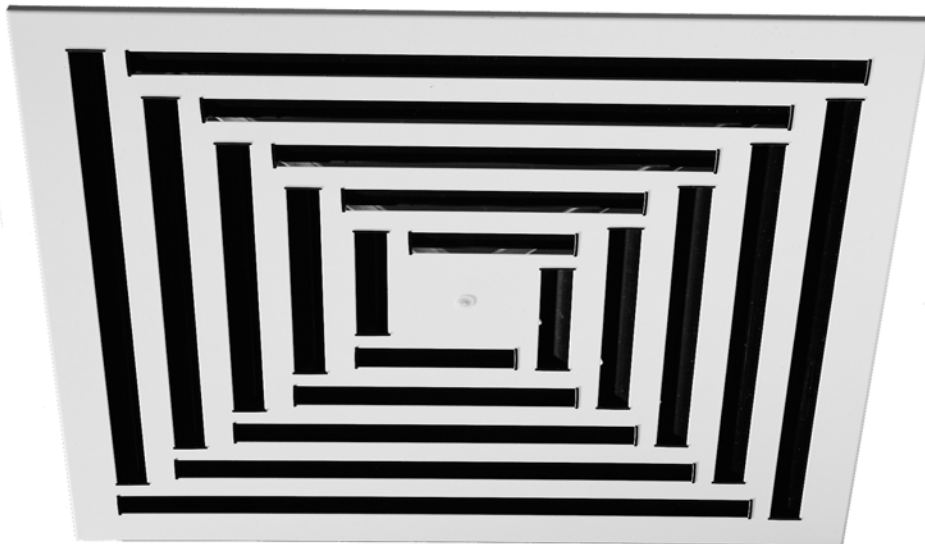

Ceiling Diffuser

Model 4-DE



Ferdinand Schad KG
Steigstraße 25-27
D-78600 Kolbingen
Telephone +49 (0) 74 63 - 980 - 0
Fax +49 (0) 74 63 - 980 - 200
info@schako.de
www.schako.de

Ceiling Diffuser Model 4-DE

Contents

Description	3
Construction	3
Model	3
Accessories	3
Fastening	4
Models and dimensions	5
Throw pattern	5
Dimensions	6
Dimensions of accessories	7
Fastening methods	8
Technical data	9
Pressure loss and noise level	9
Maximum end velocity of jet	11
Critical throw	12
Maximum penetration	13
Induction ratios	14
Temperature ratios	14
Legend	14
Order details	15
Specification texts	16

Ceiling Diffuser Model 4-DE

Description

Square ceiling diffuser type 4-DE with **manually adjustable air deflection blades**. The blades can be adjusted from below even if the diffuser is installed in order to allow an adaptation of the air throw pattern to changing room use. Both horizontal and vertical air throw patterns can be achieved. The ceiling diffuser type 4-DE can be used in **heating or cooling mode**.

The fastening without edges of the air deflection blades in the front plate allows easy cleaning. The air deflection blades made of plastic in support blade profile are aerodynamic and ensure an optimal air throw pattern. By consistently avoiding sharp edges, a low noise function is achieved.

The ceiling diffuser type 4-DE is manufactured in **supply air and return air models**. In the return air model, the air deflection blades have been omitted. In exchange, the plenum box is painted to the RAL colour 9005 (black) on the inside. If you want a perforated plate visual protection to be mounted to the return air diffuser type 4-DE-A, this must already be specified when ordering. A later installation is not possible. A hit-and-miss damper can be fitted to the diffuser instead of a plenum box when the duct is fitted or if the false ceiling has a low height.

A volumetric flow meter can be integrated into the connecting piece of the plenum box at an extra charge. The measurement error of the volumetric flow meter is $\pm 5\%$ at a connection piece velocity of 2-5 m/s and a straight flow pattern of at least $1 \times D$. The measurement is carried out with mounted diffuser. By adjusting the throttle damper, the required air volume of each diffuser can be set quickly and correctly.

The diffusion plate as well as the damper and the volume flow measuring device (if integrated) can be removed from the plenum box type SAK in ROB version to allow the use of duct cleaning robots from the room side.

Variable volumetric flow

The ceiling diffuser type 4-DE is also highly suitable for VAV systems. A stable air jet is guaranteed by the high outflow velocities, thus ensuring that the air jet does not become detached abruptly from the ceiling at small volumetric flows.

Blade setting options

Blade position 1

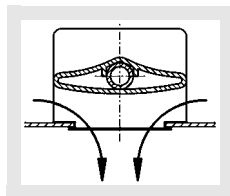

Blade position 2

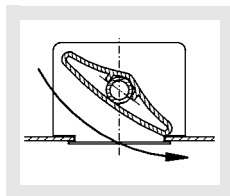

Construction

Front plate

- Sheet steel painted to RAL 9010 (white)
- Sheet steel painted to a different RAL colour (at an extra charge)
- Anodised aluminium in natural colour (E6/EV1) (only available with concealed mounting (-VM)) (at an extra charge)

Blades

- Plastic, similar to RAL colour 9010 (white) or RAL 9005 (black)
- Aluminium painted to the RAL colour of the faceplate (subsequent adjustment of blades not possible)

Model

- 4-DE-Z - Supply air
- 4-DE-A - Return air, without blades

Accessories

Plenum box (-SAK)

- Galvanised sheet steel with integrated perforated straightener (for supply air model only) and fixing lugs

Ball-impact guard (-BS)

- only possible with SM mounting and for size 800 only with SM-V mounting
- Steel painted to RAL 9010 (white), other RAL colours possible at an extra charge.

Throttle damper (-DK)

- Galvanised sheet steel, in the plenum box (-SAK)
- Damper fastening made of plastic

Rubber lip seal (-GD)

- at the plenum box connection piece, made of special rubber

Internal insulation (-li)

- thermal insulation at the inside of the plenum box

External insulation (-la)

- thermal insulation at the outside of the plenum box

ROB version (-ROB)

- Removable diffuser plate, damper and volumetric flow meter

Hit-and-miss damper (SS-K)

- Electrolytically galvanised sheet steel for air volume regulation

Volumetric flow meter (-VME)

- Mounting made of galvanised sheet steel
- Measuring sensor made of plastic
- Aluminium connections

Ceiling Diffuser Model 4-DE

Fastening

Screw mounting (-SM)

- with 4 on-site slotted shallow-raised, countersunk-tapping head screws (not possible for NW 800)

Concealed mounting (-VM)

- Pole brace fixing (at an extra charge) only available with plenum box SAK (standard for NW 800)
- fixed to the plenum box with a hexagonal socket head screw DIN EN ISO 4762 M6

Screw mounting with concealed mounting (-SM-V)

- Screw mounting (-SM) in combination with concealed mounting (-VM)
- only possible for size 800 in conjunction with ball-impact guard (-BS)

Ceiling Diffuser Model 4-DE

Models and dimensions

Throw pattern

Possible blade settings and screw mounting (SM)

Air throw "H" (horizontal)

all blades in position 2

Air throw pattern "H" is preset in factory

air jet guidance "V" (vertical)

Different blade settings, blade positions 1 and 2

Blade position 1



Blade position 2



4-DE 310

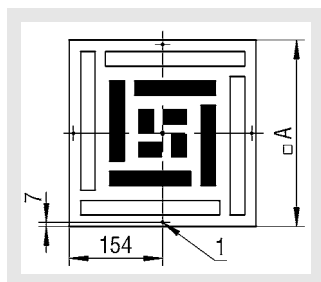

4-DE 400

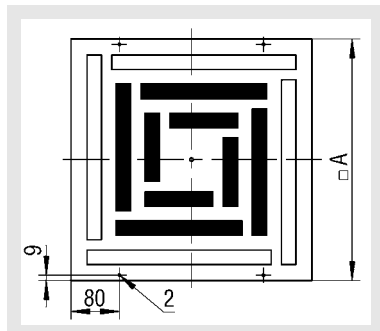

4-DE 500

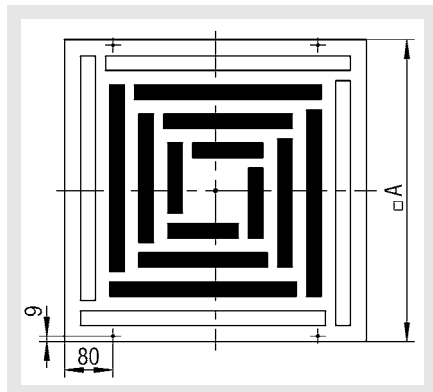

4-DE 600

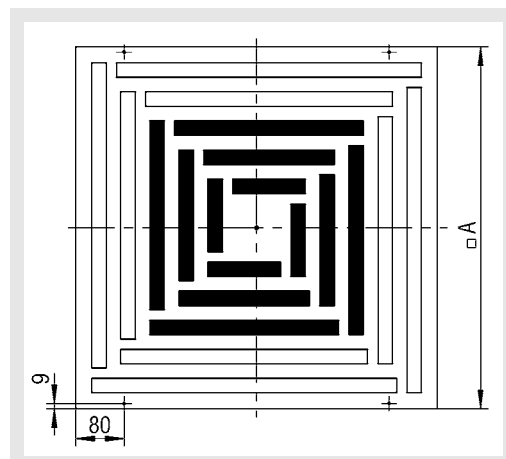

4-DE 625

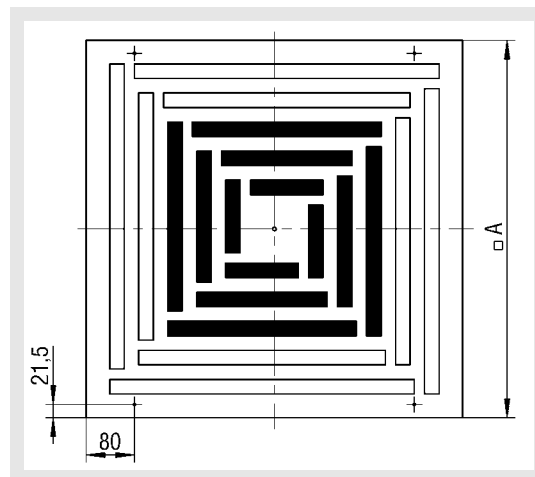

4-DE 800 with concealed mounting (VM)

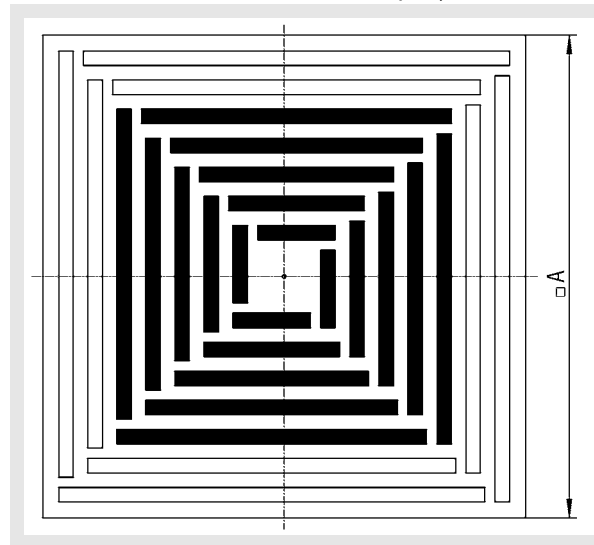

1 = Indentation for slotted shallow-raised countersunk-head tapping screw DIN ISO 7051 pitch 3.9

2 = available from NW 400. Indentation for raised countersunk head tapping screw according to DIN ISO 7051 pitch 4.8.

Ceiling Diffuser Model 4-DE

Dimensions

4-DE-Z with SAK-Z (for supply air)

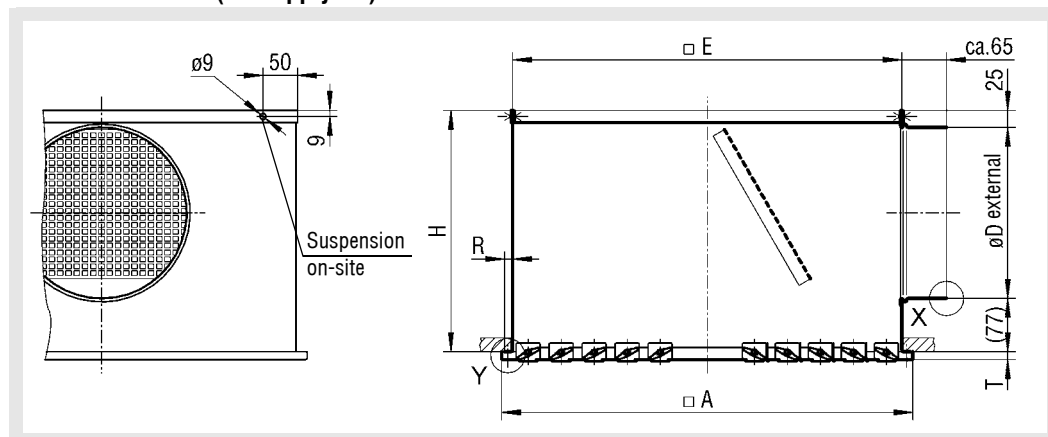

4-DE-A with SAK-A (for return air)

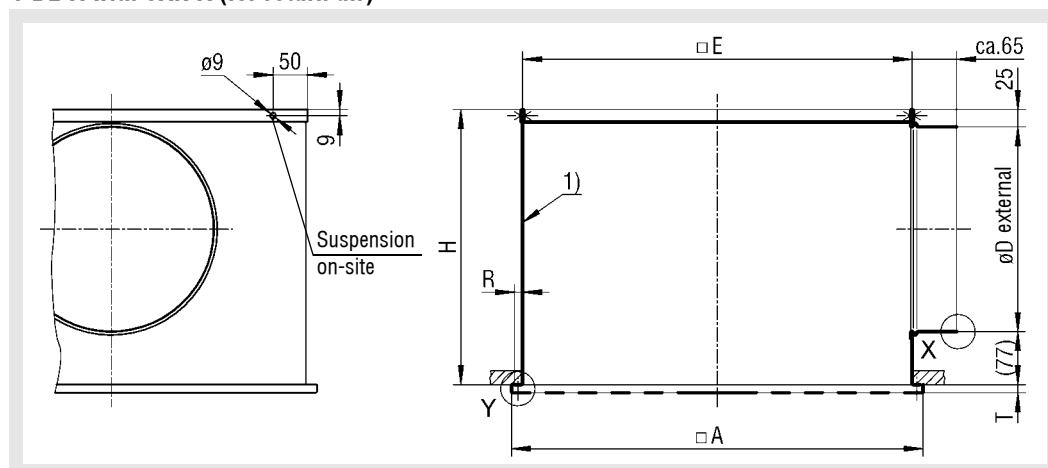

1) = Inside painted to RAL 9005 (black)

Available sizes

NW	□A	□E	R	T	SAK-Z		SAK-A	
					H	øD	H	øD
310	308	290	8	7	260	158	300	198
400	398	370	12	12	260	158	300	198
500	498	470	12	12	300	198	350	248
600	598	570	12	12	350	248	400	298
625	623	570	24	12	350	248	400	298
800	798	770	12	12	455	353	455	353

Ceiling Diffuser Model 4-DE

Dimensions of accessories

(at an extra charge):

Volumetric flow meter (-VME)

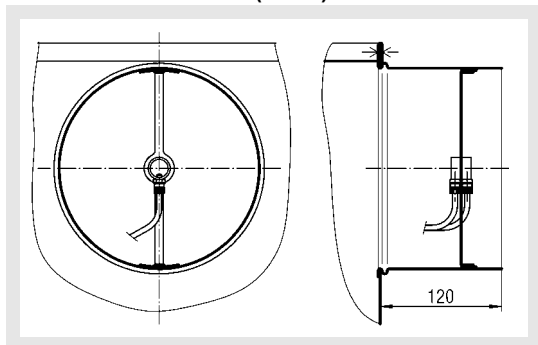

Throttle damper (-DK)

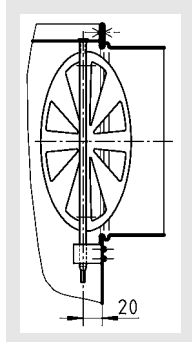

Rubber lip seal (-GD)

Detail X

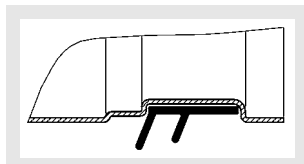

ROB version (-ROB)

Removable diffuser plate, throttle damper and volumetric flow meter.

Insulation for SAK

internal (-li)

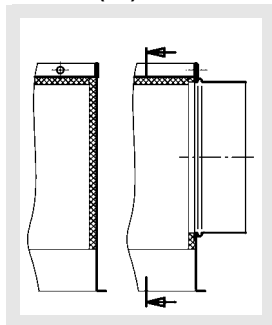

external (-la)

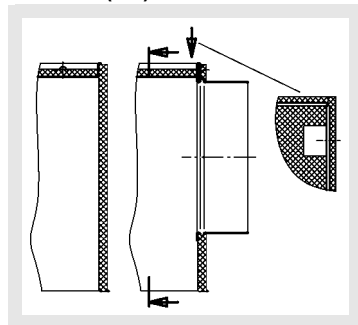

Hit-and-miss damper (SS-K)

4-DE-Z-SS-K (supply air)

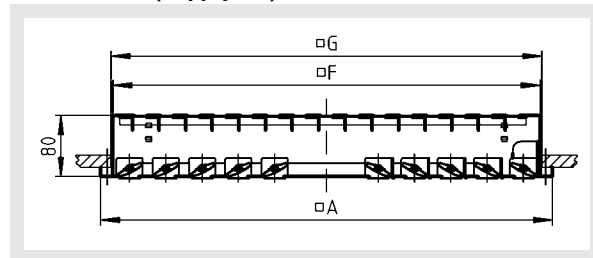

4-DE-A-SS-K (return air)

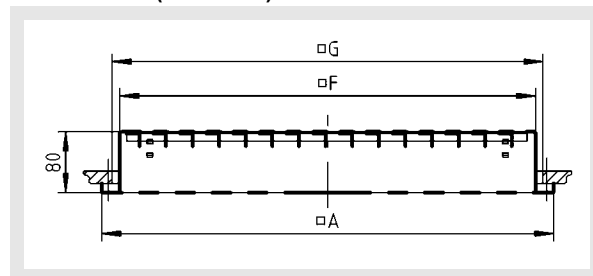

A hit-and-miss damper is only available for an aluminium faceplate together with SM mounting.

Available sizes

NW	□A	□F		□G
		SS-K-Z	SS-K-A	
310	308	280	280	295
400	398	360	350	370
500	498	460	450	470
600	598	560	550	570
625	623	560	550	570
800	798	755	750	770

Ceiling Diffuser Model 4-DE

Ball-impact guard (-BS)

(only possible with SM mounting and for size 800 only with SM-V mounting)

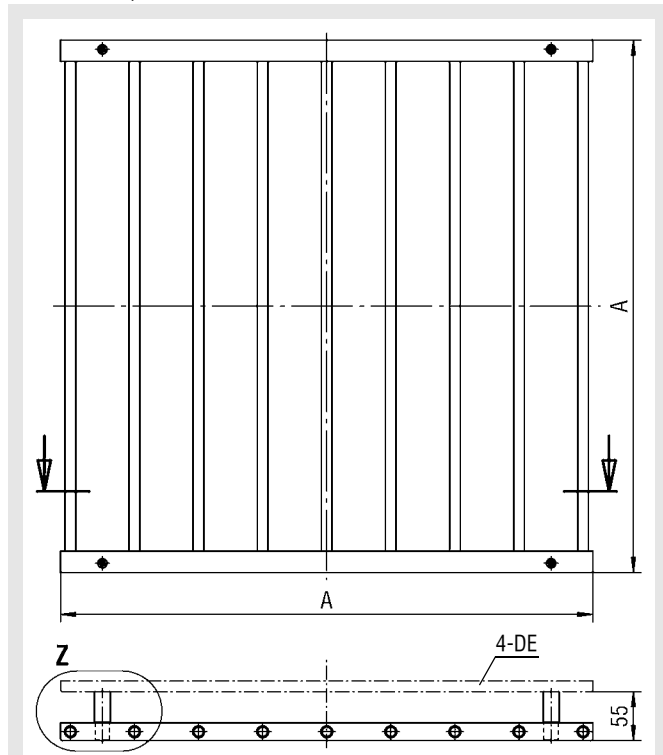

Detail Z

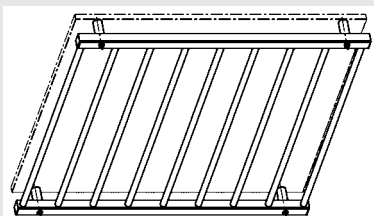
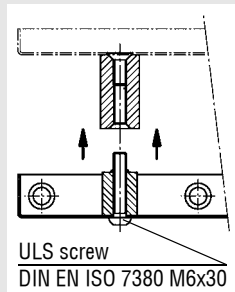

Available sizes

NW	□ A
310	308
400	398
500	498
600	598
625	623
800*	798

* Size 800:
with SM-V mounting

Dimensions SM-V mounting (for size 800 only)

SM mounting for sizes 310-625, see p. 5.

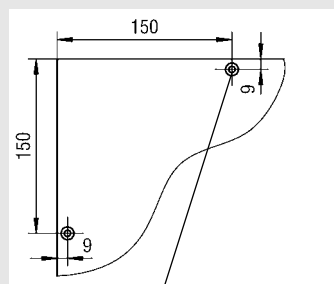

Indentation for slotted shallow-raised countersunk-head tapping screw DIN ISO 7051 pitch 4.8 (on-site)

Fastening methods

Screw mounting (-SM)

Detail Y

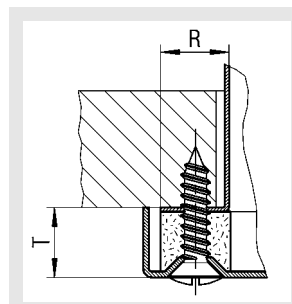

For screw mounting, the ceiling diffuser is fixed to the plenum box with 4 on-site countersunk screws (not possible for NW 800)

Concealed mounting (VM, at an extra charge)

4-DE-Z

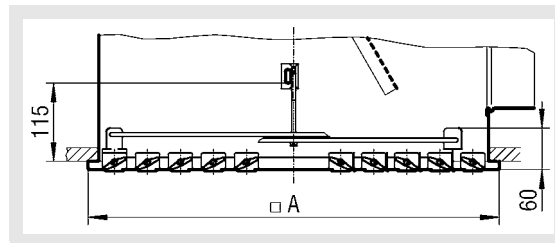

4-DE-A

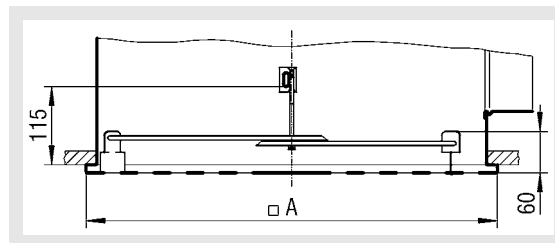

For concealed mounting the ceiling diffuser is fixed to the plenum box with a traverse and a hexagonal socket head screw DIN EN ISO 4762 M6

Ceiling Diffuser Model 4-DE

Technical data

Pressure loss and noise level

4-DE-Z (supply air), with plenum box

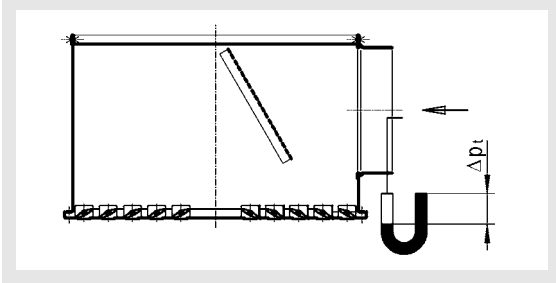

4-DE-A (return air), with plenum box

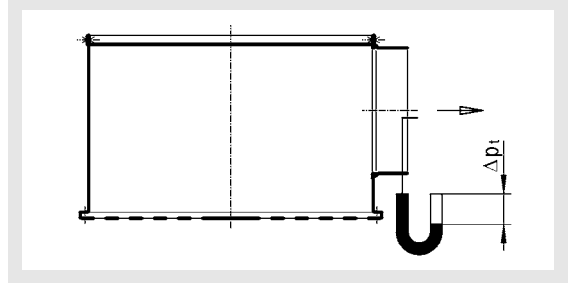

Air throw "H" (horizontal)

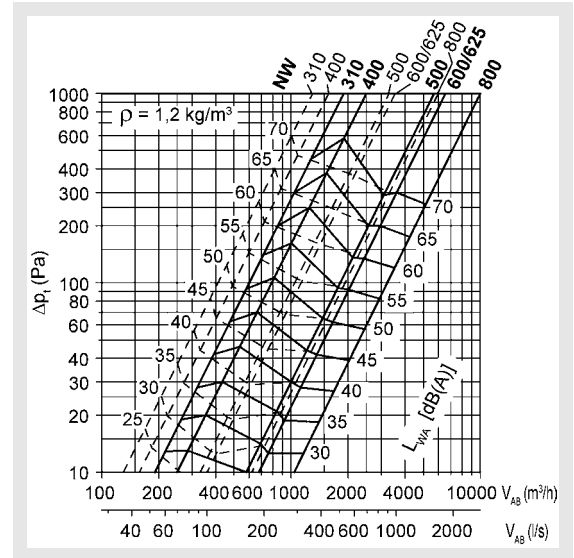
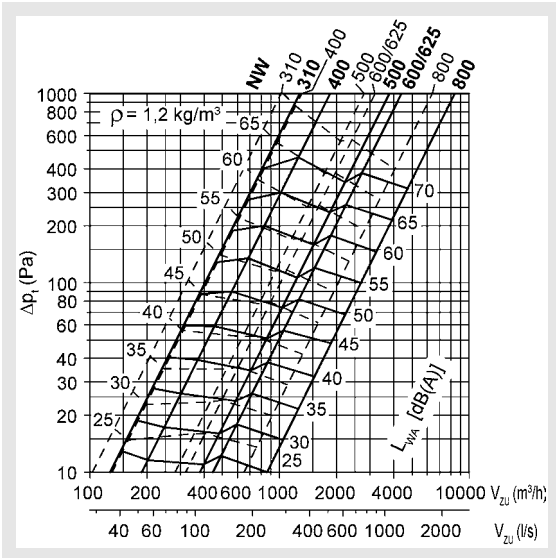

Air throw "V" (vertical)

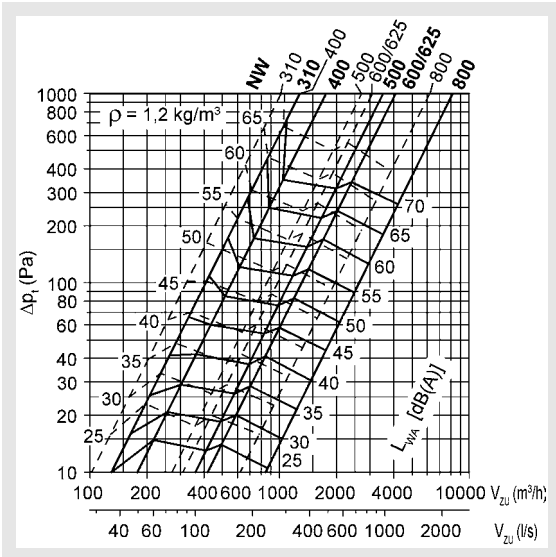

Damper position OPEN ———
 Damper position CLOSED - - - - -

Ceiling Diffuser Model 4-DE

4-DE-Z with hit-and-miss damper

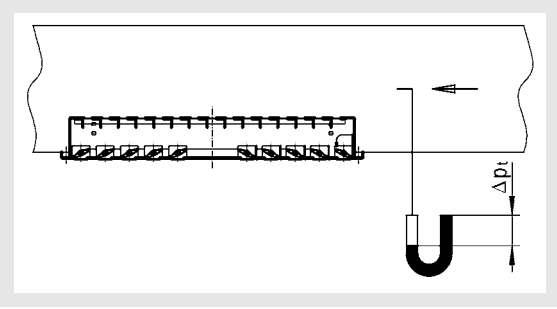

4-DE-A with hit-and-miss damper

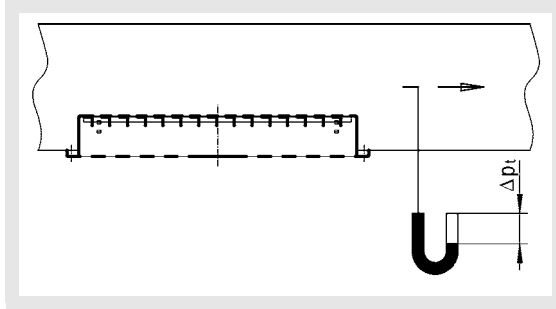

Air throw "H" (horizontal)

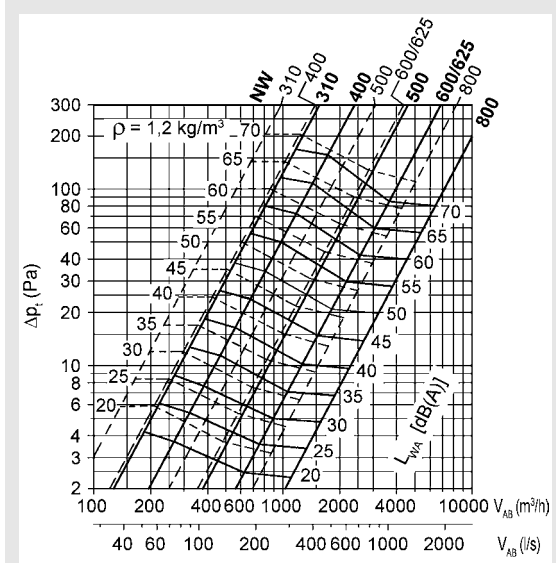
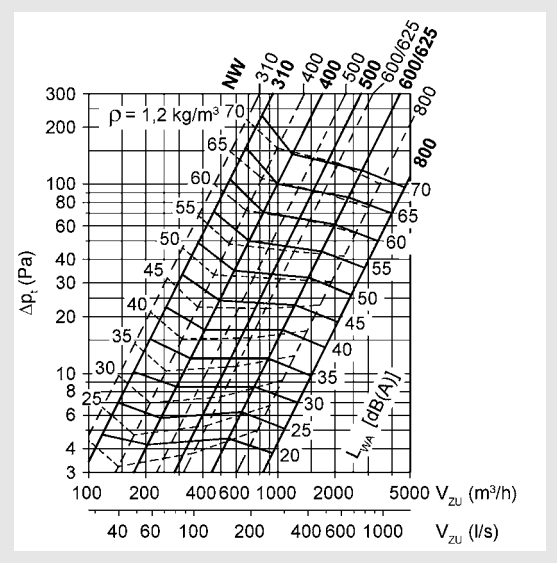

Air throw "V" (vertical)

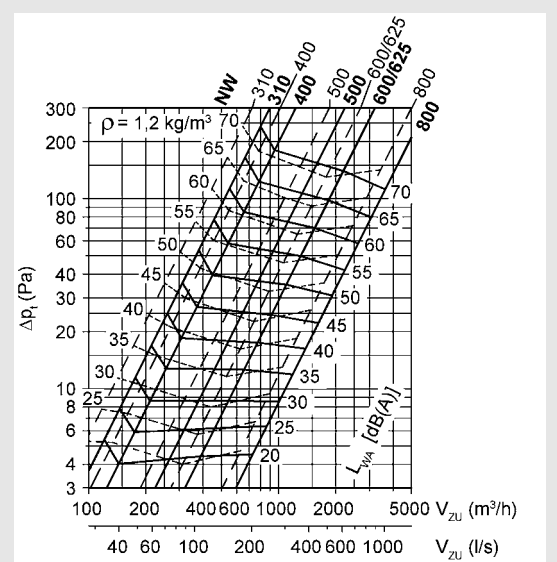

Hit-and-miss damper 100% OPEN ———
 Hit-and-miss damper 50% OPEN - - - - -

Ceiling Diffuser Model 4-DE

Maximum end velocity of jet

4-DE 310

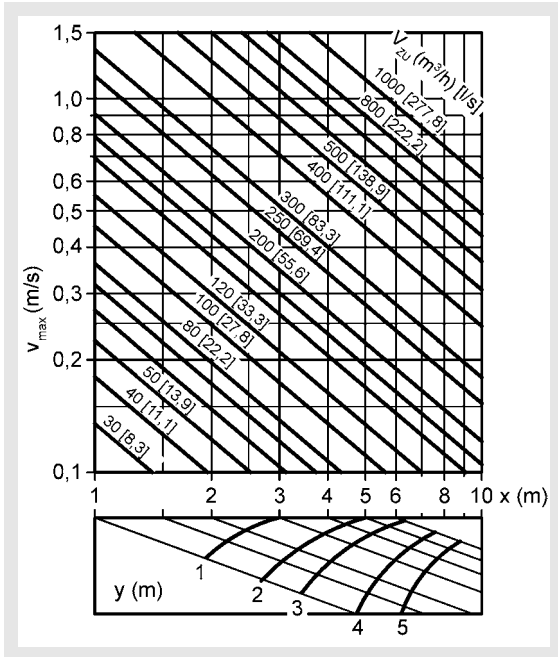

4-DE 500

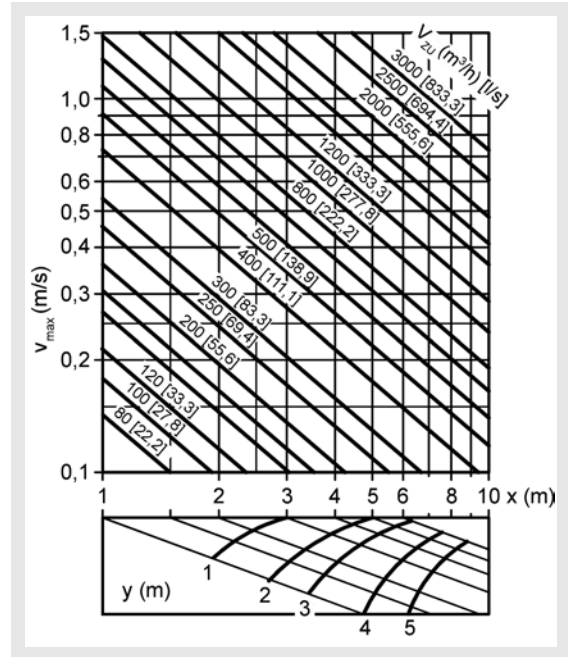

4-DE 400

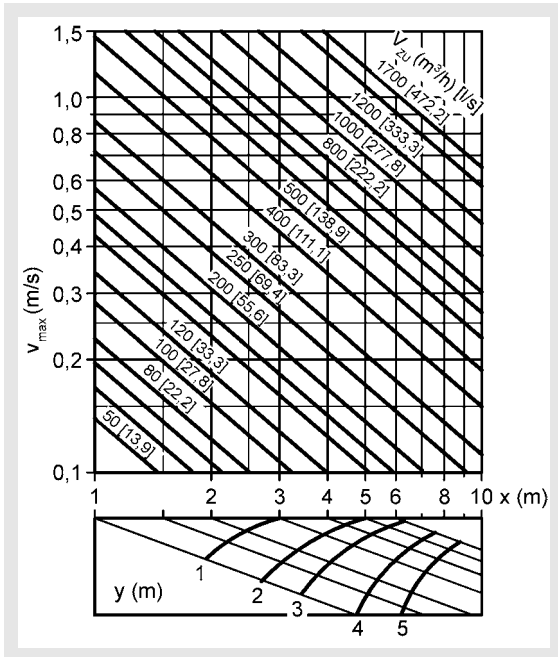

4-DE 600

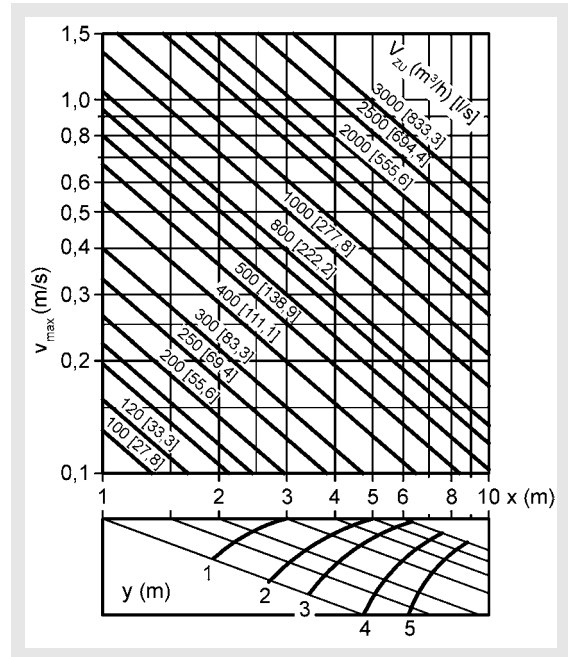

Ceiling Diffuser Model 4-DE

4-DE 800

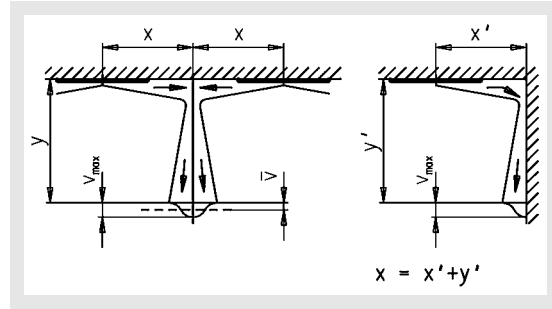
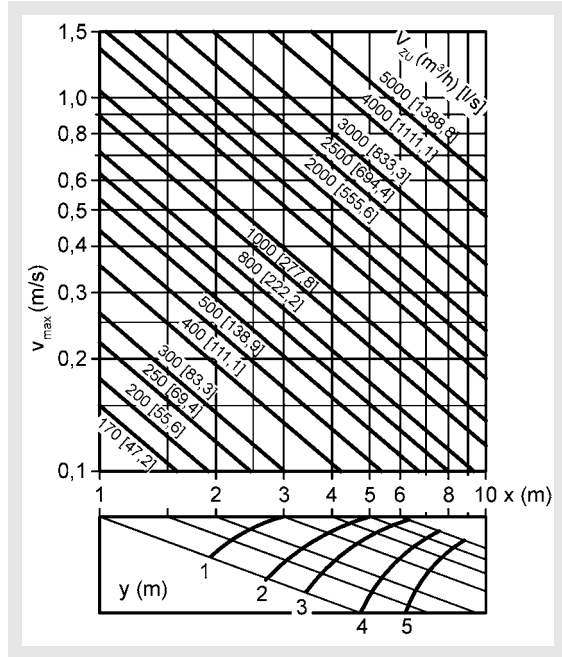

Critical throw

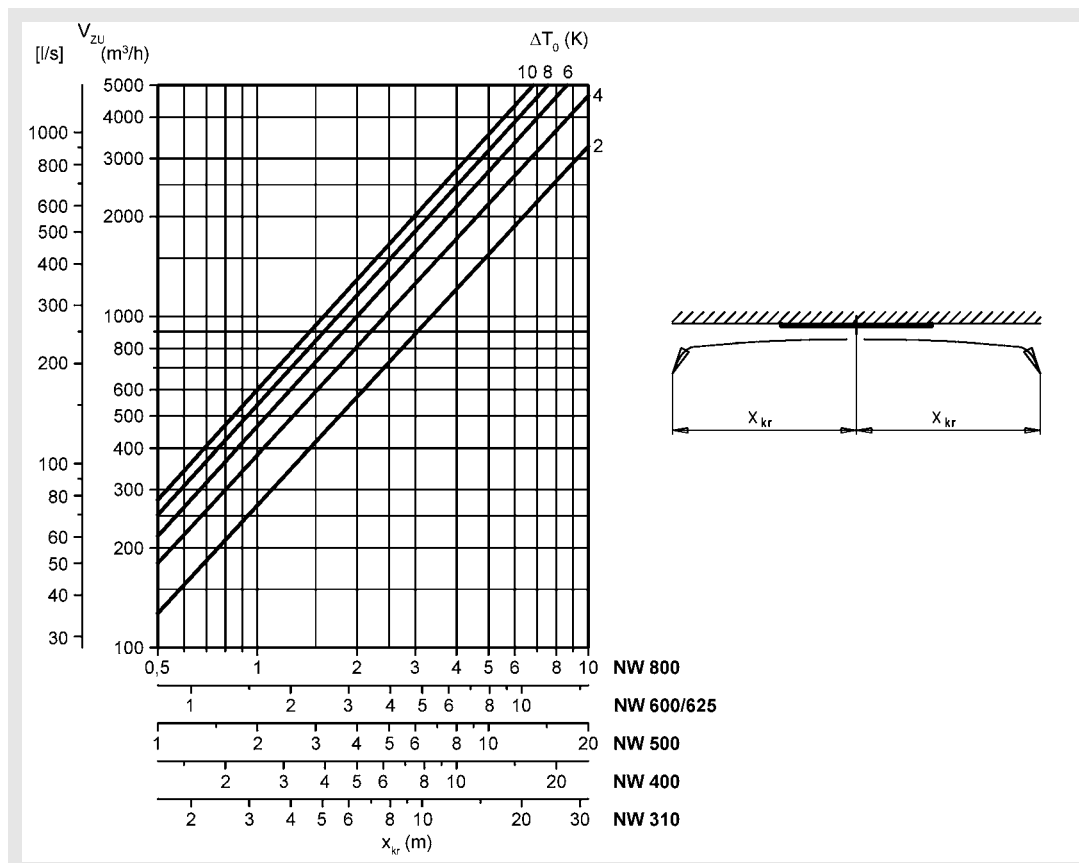

Ceiling Diffuser Model 4-DE

Maximum penetration

In heating mode

4-DE 310

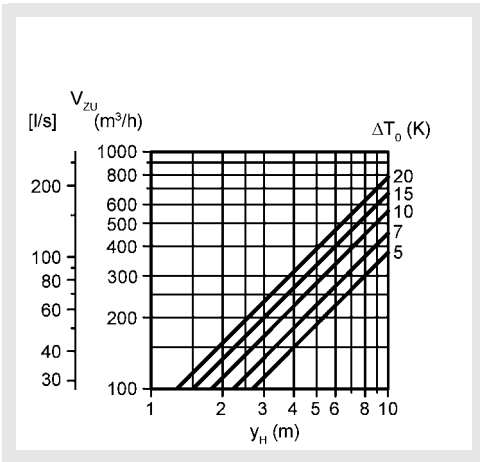

4-DE 600

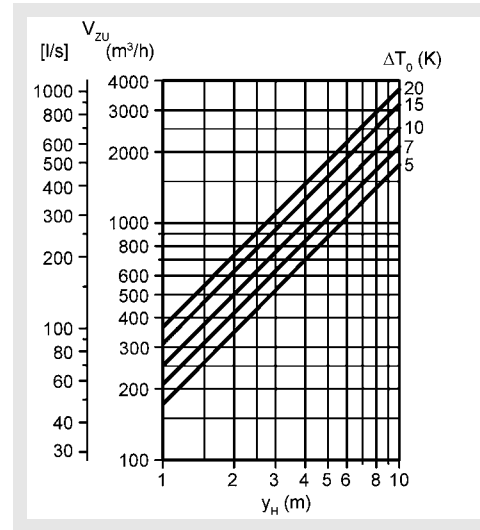

4-DE 400

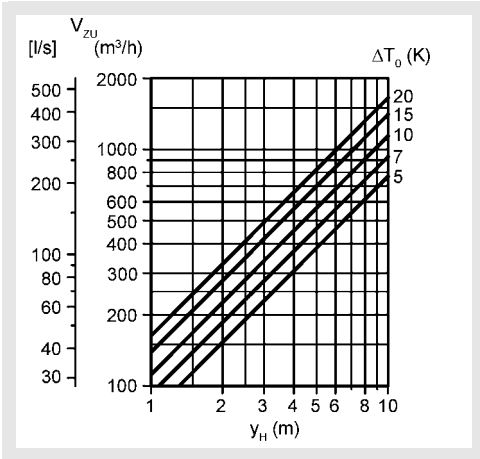

4-DE 800

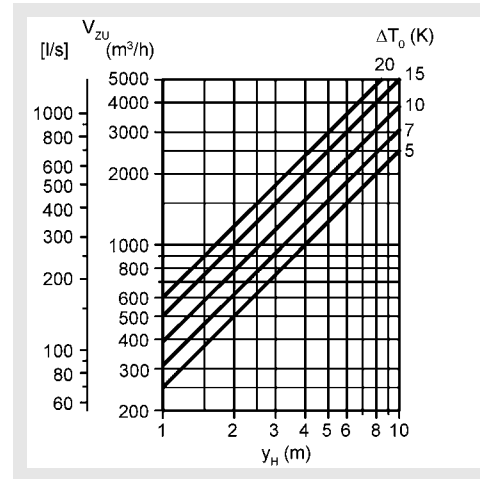

4-DE 500

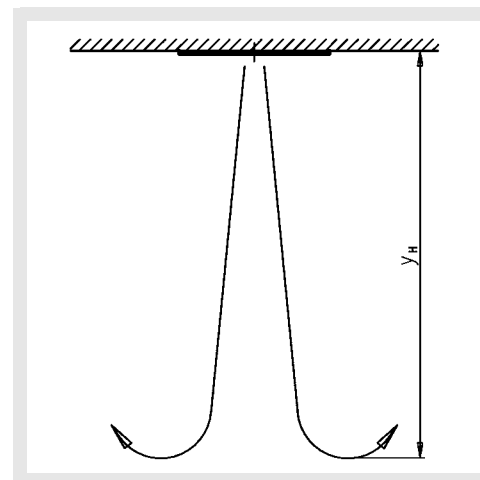
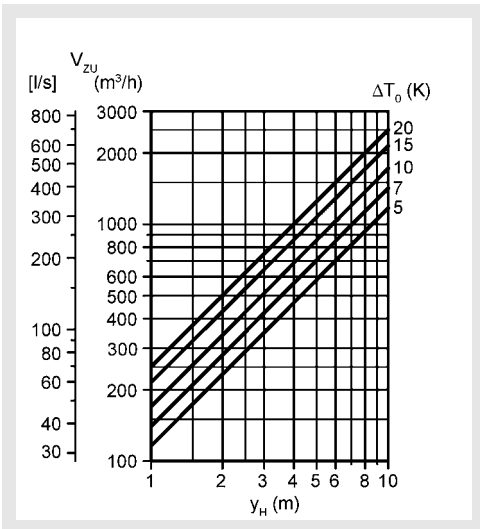

Ceiling Diffuser Model 4-DE

Induction ratios

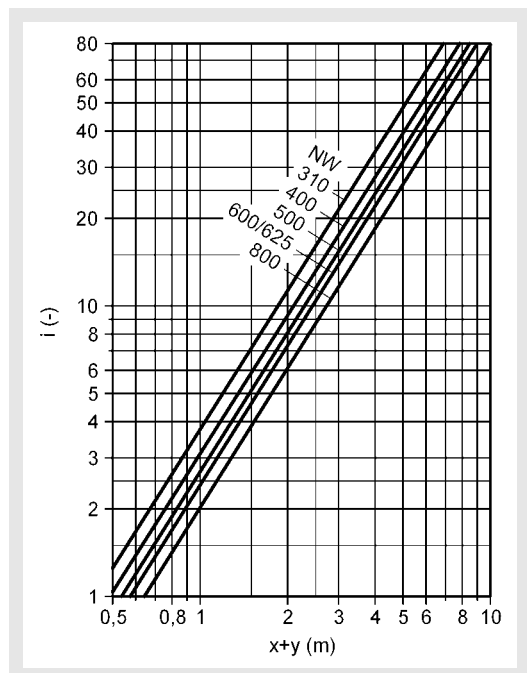

Temperature ratios

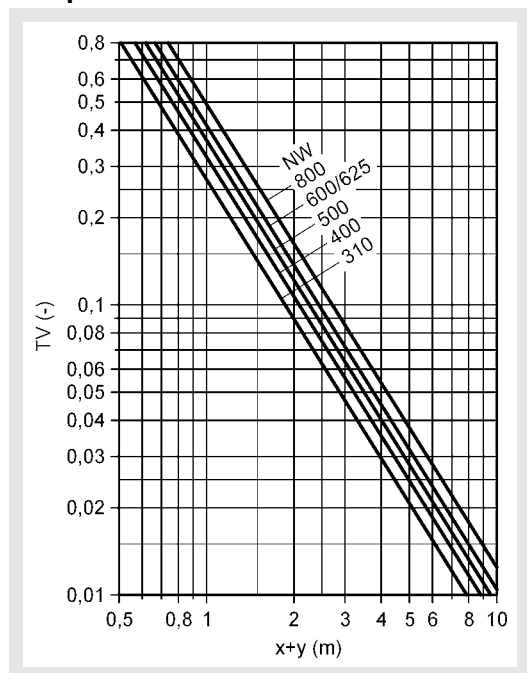

Legend

V_{ZU} (m ³ /h)	=	Supply air volume
V_{ZU} [l/s]	=	Supply air volume
V_{AB} (m ³ /h)	=	Return air volume
V_{AB} [l/s]	=	Return air volume
Δp_t (Pa)	=	Pressure loss
L_{WA} [dB(A)]	=	A-weighted sound power level
ρ (kg/m ³)	=	Density
v_{max} (m/s)	=	Maximum end velocity of jet
v (m/s)	=	Average end velocity of jet ($v = v_{max} \times 0.5$)
x (m)	=	Horizontal throw
y (m)	=	Vertical throw
$x+y$ (m)	=	horizontal + vertical throw
x_{kr} (m)	=	Critical throw
ΔT_0 (K)	=	Temperature difference between supply air temperature and room temperature ($\Delta T_0 = t_{ZU} - t_R$)
t_{ZU} (K)	=	Supply air temperature
t_R (K)	=	Room temperature
y_H (m)	=	Maximum penetration in heating mode
i (-)	=	Induction ratio ($i = V_X / V_{ZU}$)
TV (-)	=	Temperature ratio ($TV = \Delta T_X / \Delta T_0$)
NW (mm)	=	Nominal width
ΔT_X (K)	=	Temperature difference at point x
V_X (m ³ /h)	=	Total air jet volume at point x
V_X [l/s]	=	Total air jet volume at point x

Ceiling Diffuser Model 4-DE

Order details

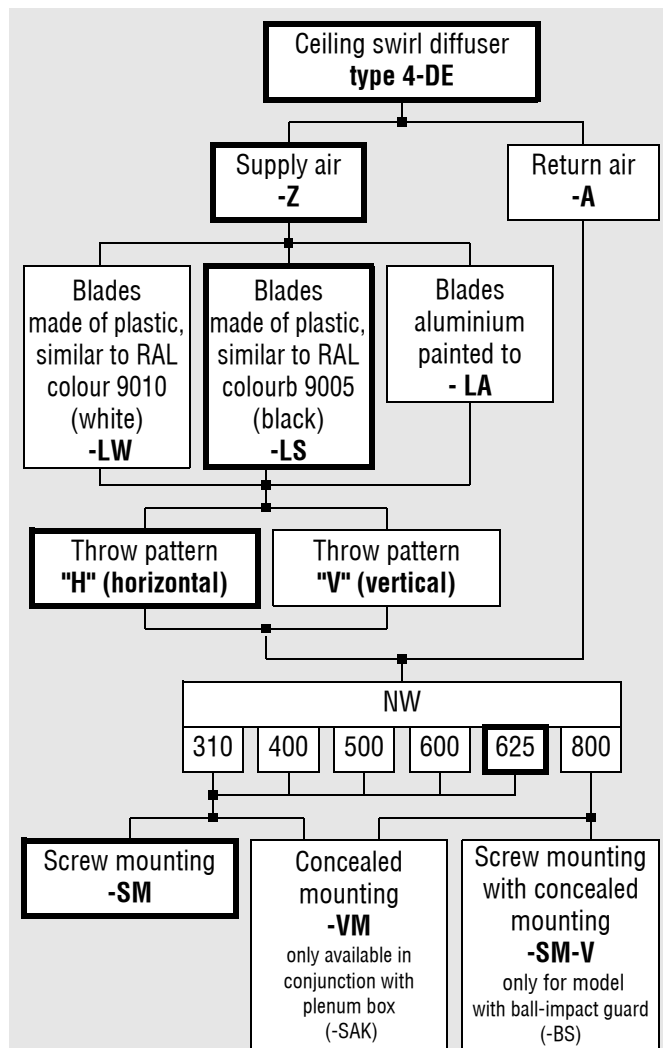

Order example:
4-DE-Z-LS-H-625-SAK-Z-GD

Unless stated otherwise, the thick-frame model will be delivered!

Accessories:

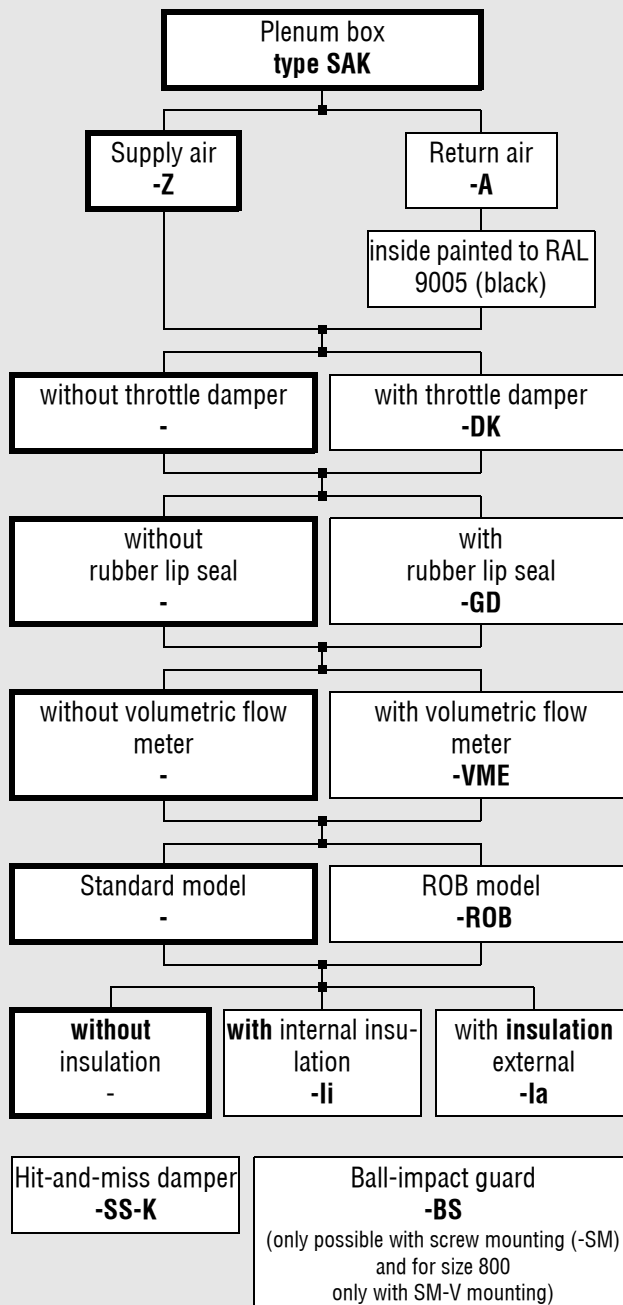

Ceiling Diffuser Model 4-DE

Specification texts

Ceiling diffuser **type 4-DE-Z** for supply air, in square design. Particularly suitable for installation in comfort rooms with high number of air changes, for clean rooms (in connection with particle filter boxes) and for VAV installations with variable volumetric flows (between 40-100%). Cooling and heating modes are possible (from -14 K to +14 K). Consisting of a high-quality powder-coated sheet steel faceplate painted to a RAL colour (RAL 9010, white, standard), with central pivoting, aerodynamic and radial fitted air deflection blades, which are individually adjustable without any tools from the diffuser side without dismantling the diffuser, in support blade profile made of plastic similar to RAL colour 9010 (white), RAL 9005 (black) or aluminium, painted individually or to the same RAL colour as the faceplate (subsequent adjustment of blades not possible). Free cross-section, resistance and sound power level constant in all blade positions. Fastened with visible screw mounting (SM). Fastening of size 800 with concealed mounting (-VM).

Product: SCHAKO **type 4-DE-Z**

- for return air, without air deflection blades

Product: SCHAKO **type 4-DE-A**

- Faceplate made of natural anodised aluminium (E6/EV1)
- with concealed mounting (-VM), made of aerodynamic aluminium profile suspended at 4 points (up to size 400) and at 6 points, respectively, only available in conjunction with plenum box.
- with screw mounting with concealed mounting (-SM-V), for mounting with ball-impact guard (only for size 800).

Accessories:

- Plenum box (-SAK) made of galvanised sheet steel, with fixing lugs.
 - Supply air model with integrated perforated straightener.
 - Return air model inside painted to RAL 9005 (black)
 - with damper (-DK) in the plenum box adjustable from below for easy air volume regulation without dismantling the front plate.
 - with volumetric flow meter (-VME)
 - with ROB version (-ROB), removable diffuser plate, throttle damper and volumetric flow meter.
 - Rubber lip seal (-GD) at the plenum box connection piece, made of special rubber.
 - with thermal insulation
 - internal (-li)
 - external (-la)
- with hit-and-miss damper (-SS-K) made of galvanised sheet steel for air volume regulation
- Ball-impact guard (-BS), made of steel with high-quality powder coating in RAL 9010 (white), other RAL colours possible at an extra charge (only possible with screw mounting (-SM) and for size 800 only with SM-V mounting).



Poppet valve

SVZ / SVA



Ferdinand Schad KG
Steigstraße 25-27
D-78600 Kolbingen
Telephone +49 (0) 74 63 - 980 - 0
Fax +49 (0) 74 63 - 980 - 200
info@schako.de
www.schako.de

Poppet Valve Model SVZ / SVA

Contents

Description	3
Construction	3
Model	3
Accessories	3
Fastening	3
Models and dimensions	4
Dimensions	4
Dimensions of accessories	5
Technical data	6
Pressure loss and noise level	6
Legend	8
Specification texts	8

Poppet Valve Model SVZ / SVA

Description

The **sheet steel** poppet valves are **suitable for use in supply air or return air installations**.

Around the poppet valve runs a cellular seal, which allows a perfect fit of the poppet valve and a secure seal.

A mounting frame is delivered for easy and quick mounting of the poppet valve. This assembly frame is connected to the ceiling with screws. **The poppet valve is then mounted to the mounting frame by means of a bayonet catch.**

To set the required air volume, the valve disc must be rotated. The air volume setting is fixed using a counter nut.

For the supply air poppet valves, a cover is fitted to the valve disc to reduce noise levels.

In the shock-proof model, the return air poppet valve type SVA is also suitable for use in protection rooms of civil protection.

Construction

Mounting ring

- Plastic, similar to the RAL colour 9010 (white), up to size 150
- Galvanized sheet steel

Front frame

- Sheet steel painted to RAL 9010 (white)

Threaded spindle

- steel

Valve disc

- Sheet steel painted to RAL 9010 (white)

Valve disc cover (SVZ only)

- Galvanized sheet steel

Model

SVZ - Supply air

SVA - return air

Accessories

Panelled cover plate (-PA)

- painted sheet steel RAL 9010 (white) with integrated mounting ring

Saddle bracket (-SA)

- Galvanised sheet steel with integrated mounting ring

Fastening

Screw mounting (-SM)

- Mounting frame is fitted to the cover plate

Poppet Valve Model SVZ / SVA

Models and dimensions

Dimensions

SVZ (supply air)

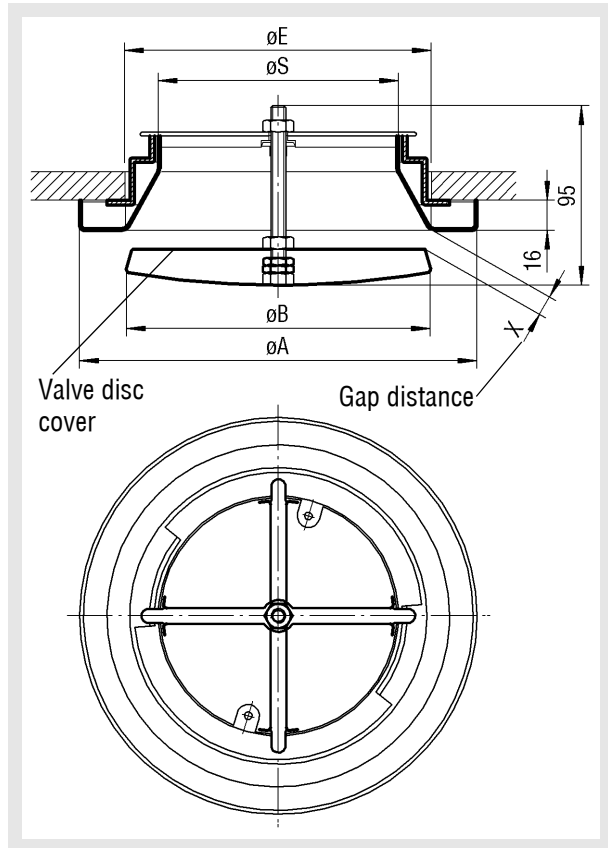

SVA (return air)

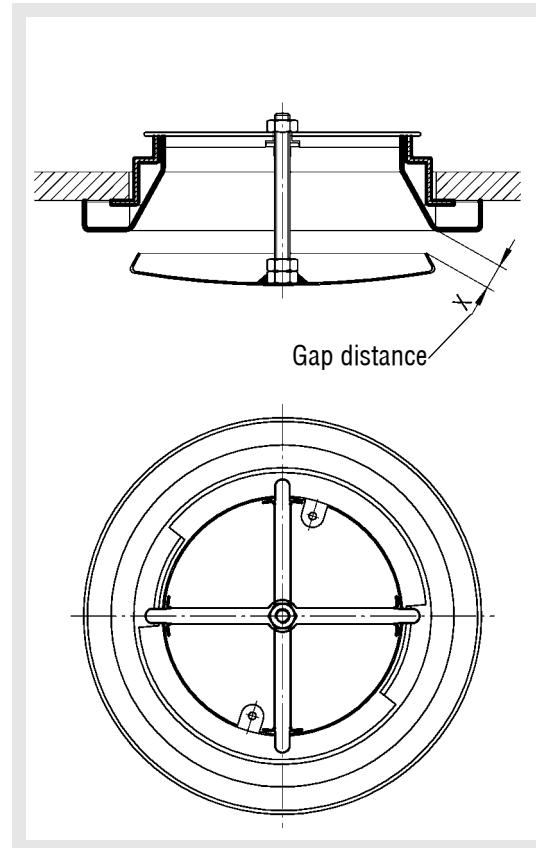

Available sizes SVZ / SVA

NW	$\varnothing A$	$\varnothing B$	$\varnothing S$	$\varnothing E$
100	150	100	65	105
150	200	150	115	155
160	210	162	126	165
200	250	200	165	205

Mounting ring

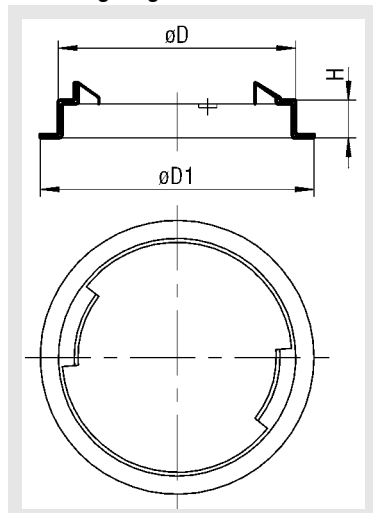

Available sizes of mounting ring

NW	$\varnothing D$		$\varnothing D1$		H	
	Steel	Plastic	Steel	Plastic	Steel	Plastic
100	97	98	125	118	22	25
150	148	148	185	168	24	25
160	157	-	193	-	27	-
200	197	-	220	-	27	-

Poppet Valve Model SVZ / SVA

Dimensions of accessories

Panelled cover plate (-PA)

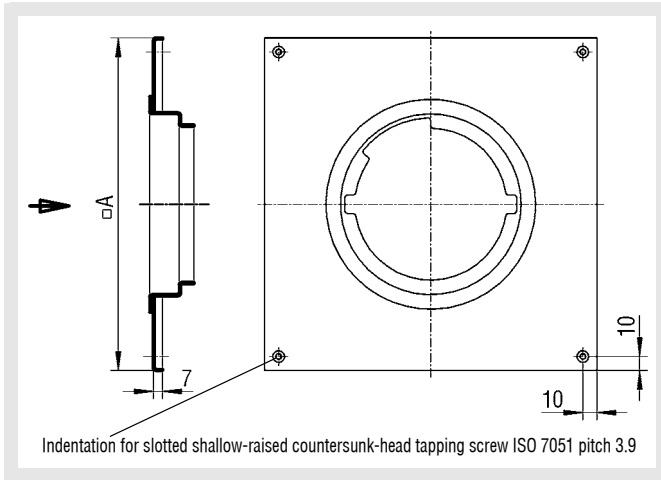

Saddle bracket (-SA)

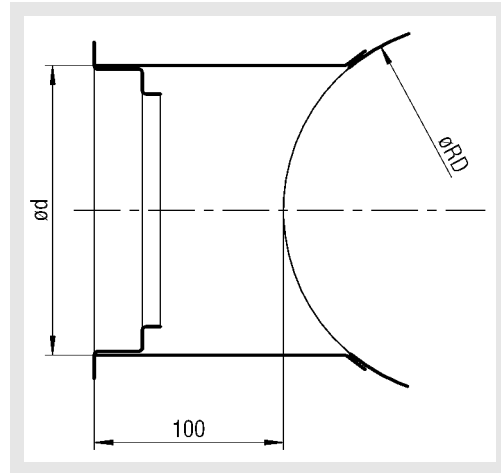

Available sizes of accessories

NW	A	$\varnothing RD$	$\varnothing d$
100	185	150	100
150	285	200	150
160	285	200	160
200	285	250	200

Poppet Valve Model SVZ / SVA

Technical data

Pressure loss and noise level

SVZ 100

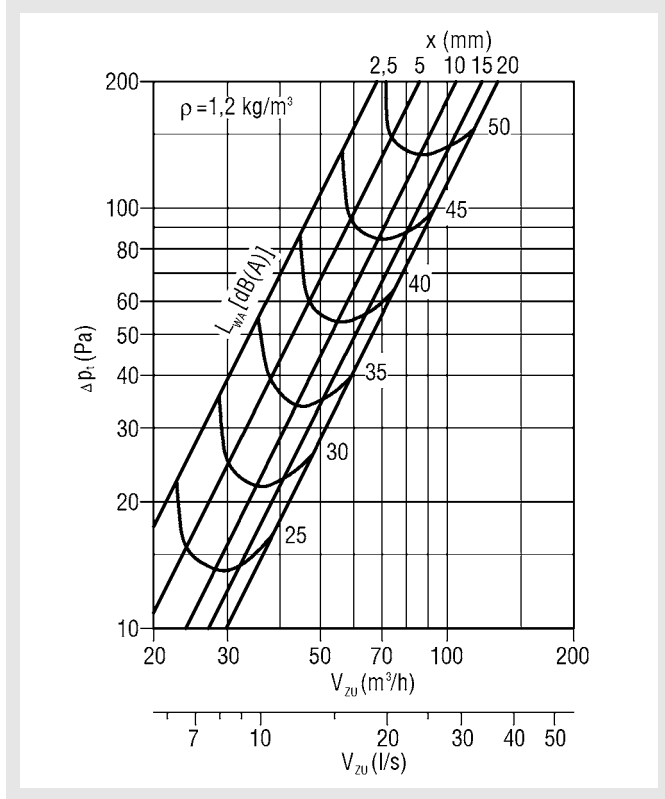

SVZ 200

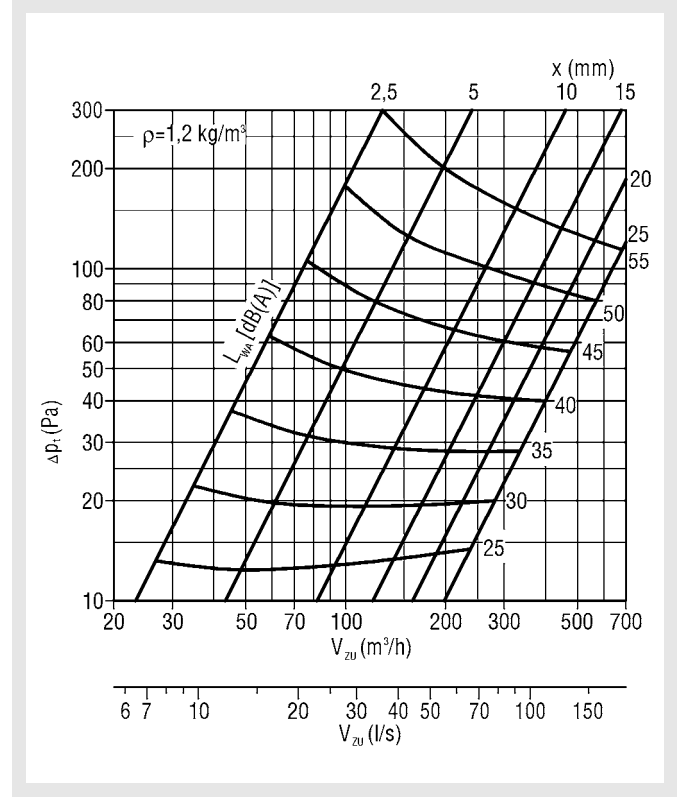

SVZ 150 / 160

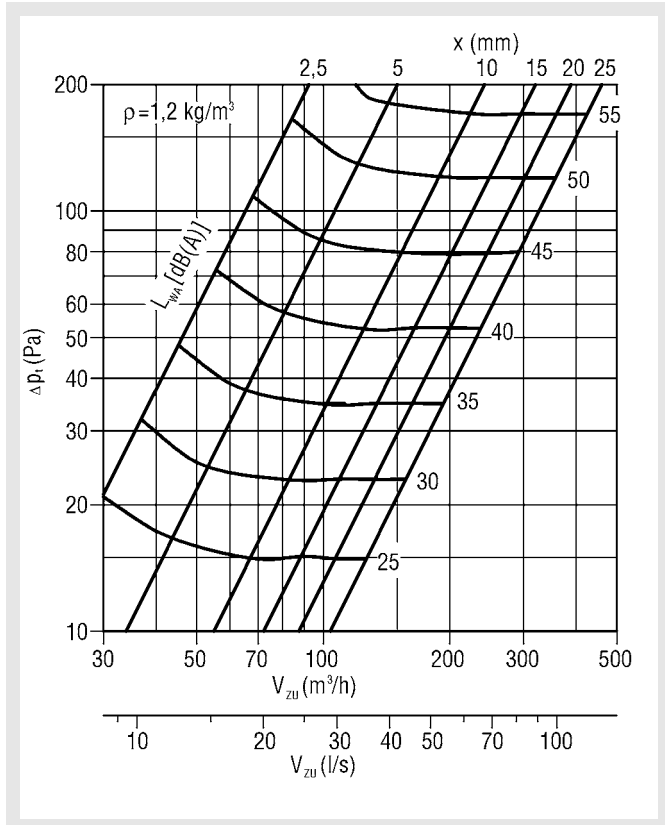

Supply air

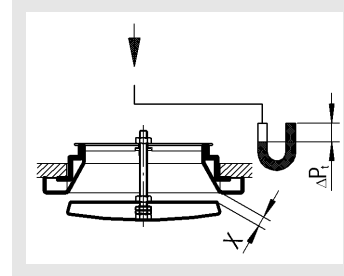

Poppet Valve Model SVZ / SVA

SVA 100

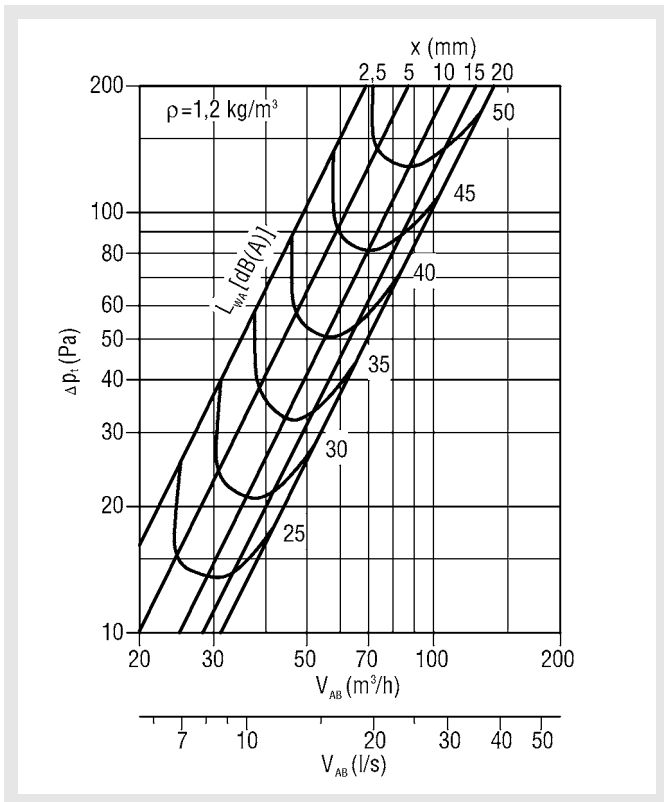

SVA 200

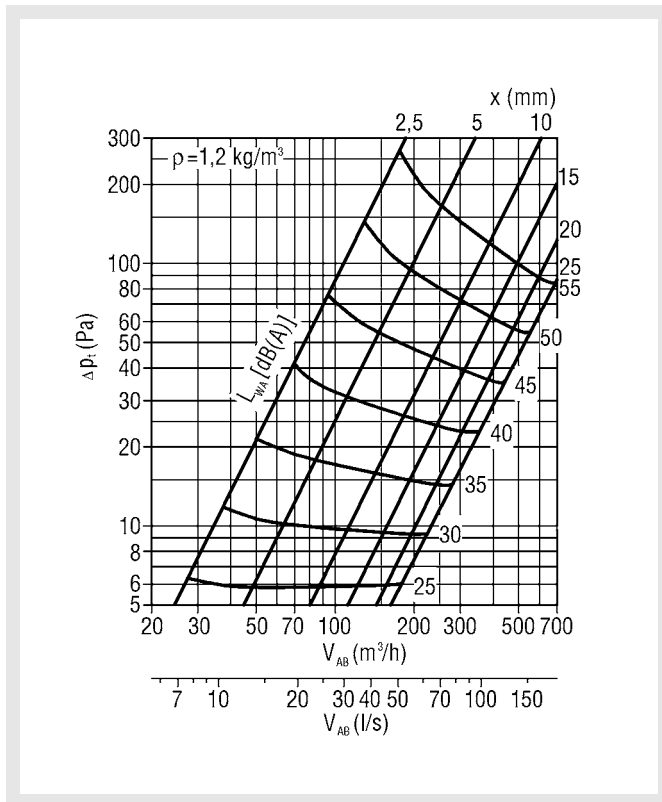

SVA 150 / 160

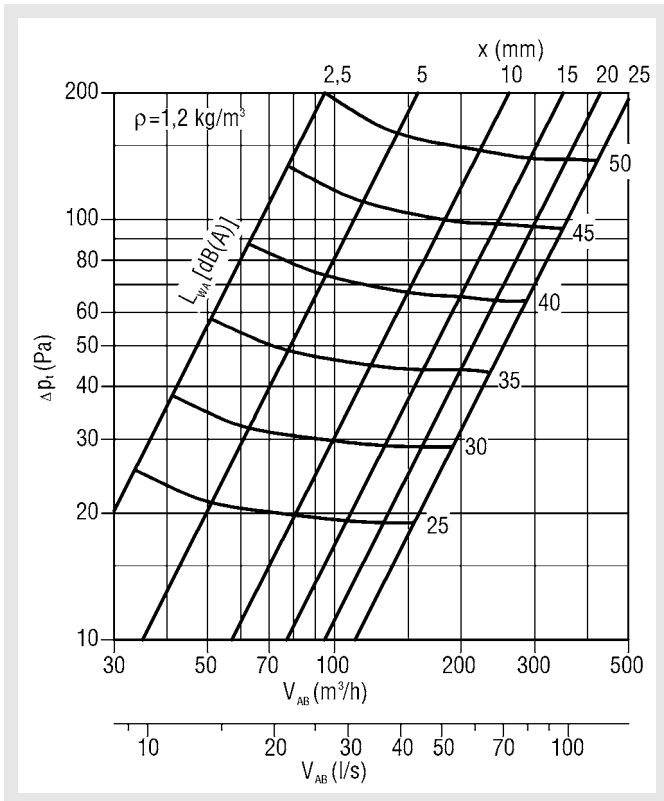

return air

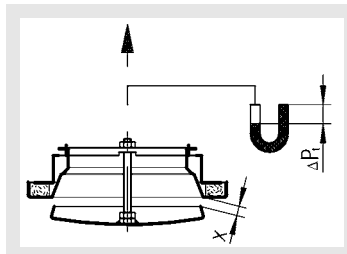

Poppet Valve Model SVZ / SVA

Legend

V_{ZU}	(m ³ /h)	= Supply air volume
V_{ZU}	[l/s]	= Supply air volume
V_{AB}	(m ³ /h)	= Return air volume
V_{AB}	[l/s]	= Return air volume
x	(mm)	= Gap distance
Δp_t	(Pa)	= Pressure loss
L_{WA}	[dB(A)]	= A-weighted sound power level
δ	(kg/m ³)	= Density
NW	(mm)	= Nominal value

Specification texts

Supply air poppet valve consisting of round front frame made of sheet steel painted to RAL 9010 (white) with circumferential foam seal. With cover on the adjustable valve disc made of galvanised sheet steel, painted to RAL 9010 (white) for air volume regulation. Counter nut to ensure air volume setting and threaded stem made of galvanised steel. Includes plastic mounting ring up to size 150 colour similar to RAL 9010 (white), or made of galvanised sheet steel with bayonet catch.

Product: SCHAKO **type SVZ**

- Poppet valve for return air with adjustable valve disc without cover on valve disc.

Product: SCHAKO **type SVA**

- Shock-proof model for use in protection rooms for civil protection.

Accessories:

- Panelled cover plate (-PA) made of sheet steel painted to RAL 9010 (white) with integrated mounting ring made of galvanised sheet steel.
- Saddle bracket (-SA) with integrated mounted ring made of galvanised sheet steel.

Slot diffusers for ceiling installation

Type PureLine18



Spigot with optional damper blade and optional lip seal

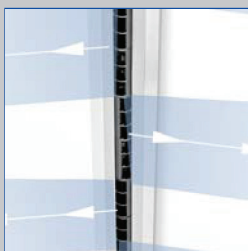

Alternating horizontal air discharge

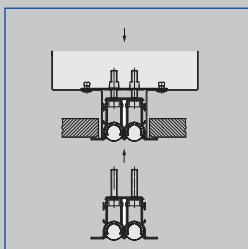

Detachable diffuser face fixing



PL18-2/.../B00/P1-RAL 9010, installation in continuous ceilings



Particularly slim diffuser face, available in numerous variants for many different installation situations

Slot diffusers with 18 mm diffuser face (nominal width) and adjustable air control elements

- Nominal length 600 – 2000 mm (length of air control element 100 mm), 1 or 2 slots
- Volume flow rate range 5 – 84 l/s or 17 – 302 m³/h
- Individually adjustable air control elements for horizontal, angled or vertical air discharge
- One-way or alternating air discharge meets individual local requirements
- Uniform air pattern reduces contamination of the ceiling due to the induction of room air
- Air control elements have grooves that allow for precise positioning

Optional equipment and accessories

- Attractive appearance due to extruded aluminium sections with anodised finish or powder coating
- Symmetric or asymmetric position of plenum box
- Plenum box with lining
- End plates, end angles, corner sections
- Different looks due to choice of black, grey or white air control elements

Type		Page
PureLine18	General information	PL18 – 2
	Function	PL18 – 4
	Technical data	PL18 – 7
	Quick sizing	PL18 – 8
	Specification text	PL18 – 12
	Order code	PL18 – 13
	Variants	PL18 – 16
	Dimensions and weight	PL18 – 18
	Installation examples	PL18 – 24
	Installation details	PL18 – 25
	Commissioning	PL18 – 28
	Basic information and nomenclature	PL18 – 29

Application

Application

- Type PureLine18 slot diffusers are used as supply air or extract air devices in comfort zones
- Particularly unobtrusive diffuser due to its sleek design
- Installation into suspended ceilings
- For room heights up to 4 m (lower edge of suspended ceiling)
- For suspended ceilings; suitable for restricted ceiling voids due to the low overall height of the plenum box
- Suitable for continuous linear arrangement
- Adjustable air control elements allow for horizontal, angled or vertical air discharge
- Mixed flow system with one-way or alternating air discharge, can be adapted to the building structure
- High induction results in a rapid reduction of the temperature difference and airflow velocity (supply air variant)
- For variable and constant volume flows
- For supply air to room air temperature differences from –10 to +10 K

Special characteristics

- Uniform air pattern reduces contamination of the ceiling due to the induction of room air
- Horizontal, angled or vertical air discharge by means of manually adjustable air control elements
- Comfortable indoor climate due to high induction and rapid reduction of temperature differences and airflow velocities
- High-quality look thanks to anodised extruded aluminium sections (E6-C-0, natural colour) or powder coating (RAL CLASSIC colour)
- Diffuser face has been optimised for maximum volume flow rate at low sound power levels
- Suitable for continuous linear arrangement

Nominal sizes

- L_N : 600, 700, 800, 900, 1000, 1100, 1200, 1300, 1400, 1500, 1600, 1700, 1800, 1900, 2000 mm
- Diffuser face also available in intermediate sizes

Description

Variants

- PL18-*: 1 or 2 slots
- PL18-*-DF: Diffuser face with spring clip
- PL18-*-DS: Diffuser face with extended border (B00) and screw fixing
- PL18-*-PB: Plenum box for screw fixing
- PL18-*-PF: Diffuser face and plenum box, non-detachable fixing
- PL18-*-SF: Diffuser face and plenum box, detachable fixing
- PL18-*-CS: Corner section

Position of plenum box on the front diffuser

- Central position
- On the left (LE)
- On the right (RI)

Plenum box variant

- Symmetric position of plenum box, side entry spigot (HS)
- Symmetric position of plenum box, top entry spigot (VS)
- Asymmetric position of plenum box, side entry spigot (HA)

Construction

Diffuser face finish

- Anodised, E6-C-0, natural colour
- P1: Powder-coated RAL 9010, pure white, gloss level 50%
- P1: Powder-coated RAL 9006, white aluminium, gloss level 30%
- P1: Powder-coated in any other RAL CLASSIC colour, gloss level 70%

Attachments

- D: Damper blade for volume flow rate balancing
- LS: Lip seal
- L: Internal insulation
- EP: Two end plates
- EA: Two end angles

Single diffusers are factory fitted with end plates or end angles.

Accessories

- EP: Two end plates
- EA: Two end angles

For a continuous linear arrangement the end plates or end angles have to be ordered separately and fitted by others.

Construction features

- Spigot suitable for circular ducts to EN 1506 or EN 13180
- 4 suspension points for on-site installation (by others)
- The manually adjustable air control elements have grooves that make it easier to adjust the elements and lock them in the required position
- Spigot with groove for lip seal (if accessory with lip seal has been ordered)
- Diffuser face sizes from 600 to 2000 mm, in increments of 1 mm
- Plenum boxes are only available in nominal lengths

Materials and surfaces

- Diffuser face made from extruded aluminium sections
- Air control elements made of ABS plastic, UL 94, V-0, flame retardant
- Plenum box made of galvanised sheet steel
- End plates and end angles made of aluminium
- Lip seal made of rubber
- Lining is mineral wool with vinyl closed cell foam
- Diffuser face with anodised finish, E6-C-0, natural colour
- P1: Powder-coated, RAL CLASSIC colour
- Air control elements similar to RAL 9005, black
- G: Air control elements similar to RAL 9006, grey
- W: Air control elements similar to RAL 9010, white

Mineral wool

- Where the mineral wool comes into contact with air, it is faced with glass fibre fabric as a protection against abrasion due to airflow velocities up to 20 m/s
- To EN 13501, fire rating class A1, non-combustible
- RAL quality mark RAL-GZ 388
- Biosoluble and hence hygienically safe according to the German TRGS 905 (Technical Rules for Hazardous Substances) and EU directive 97/69/EC
- Inert to fungal and bacterial growth

Standards and guidelines

- Sound power level of the air-regenerated noise measured according to EN ISO 5135

Maintenance

- Maintenance-free as construction and materials are not subject to wear
- Inspection and cleaning to VDI 6022

PL plenum box, positioned on the left, in the centre, on the right

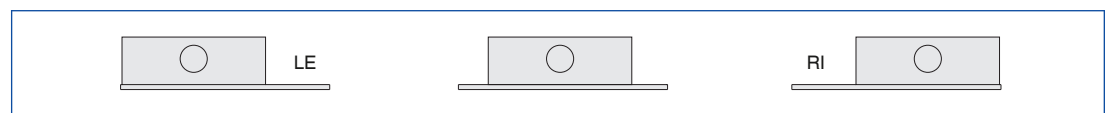

Functional description

Slot diffusers direct the air from air conditioning systems into the room, either horizontally, at an angle or vertically.

The resulting airflow induces high levels of room air, thereby rapidly reducing the airflow velocity and the temperature difference between supply air and room air.

The result is a mixed flow ventilation in comfort zones, with good overall room ventilation, creating only very little turbulence in the occupied zone.

Type PureLine18 slot diffusers are factory fitted with manually adjustable air control elements.

The air pattern can be adjusted to meet different local requirements.

Air discharge is one-way or alternating horizontal.

Other patterns: heating mode with vertical air discharge; angled air discharge.

The supply air to room air temperature difference may range from -10 to $+10$ K.

A damper blade (optional) simplifies volume flow rate balancing for commissioning.

To give rooms an aesthetic, uniform look, PureLine18 diffusers may also be used for extract air.

Schematic illustration of PL18-*-SF

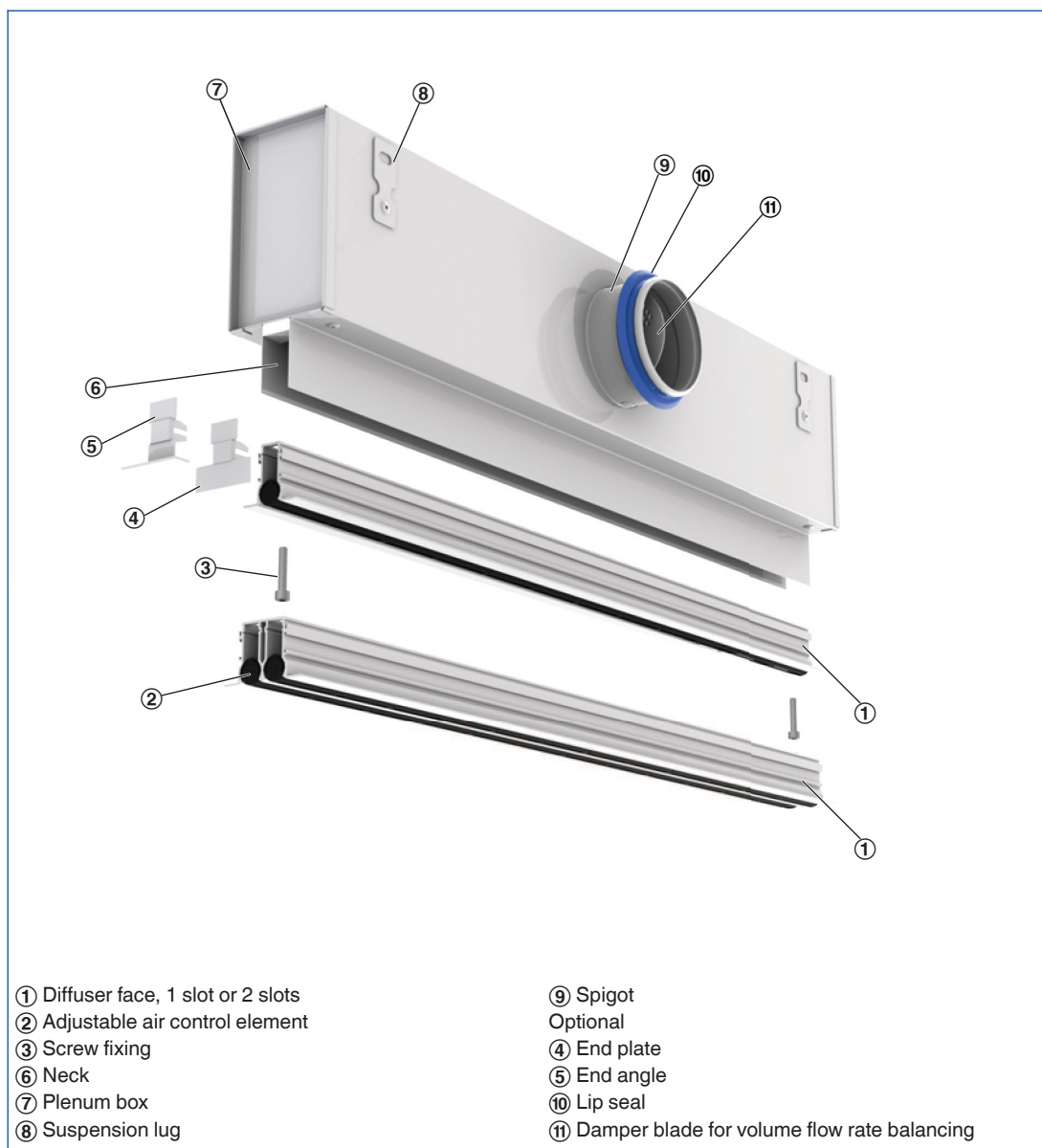

Vertical air discharge

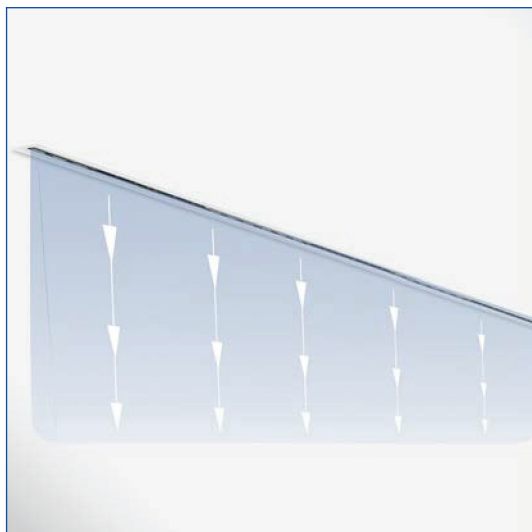

Vertical air discharge (V)

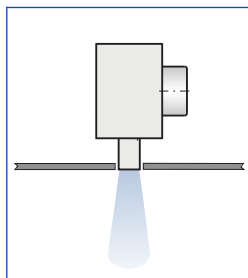

Setting of the air control elements

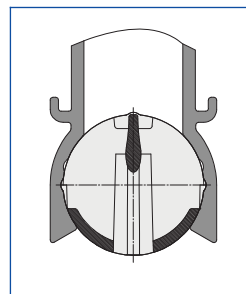

Air discharge: vertical

One-way horizontal air discharge to the left



One-way horizontal left (HL)

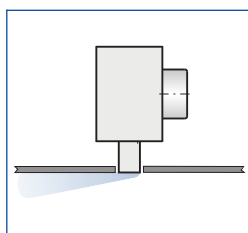

Setting of the air control elements

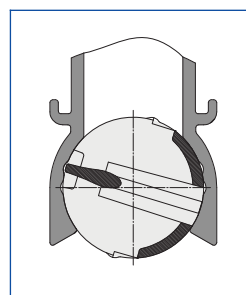

Air discharge:
horizontal left

One-way horizontal air discharge to the right



One-way horizontal right (HR)

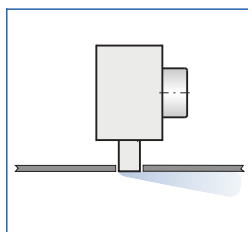

Setting of the air control elements

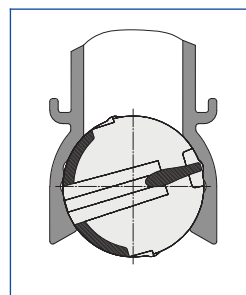

Air discharge:
horizontal right



elox, lak

Technické parametry

Provedení

Přívodní/odvodní vyústky s nastavitelnými listy s roztečí 20 mm.

Konstrukce

Obdélníkové vyústky komfortní (včetně listů) jsou vyrobeny z Al profilu opatřeného transparentním eloxem. Vypalovací barva v základních odstínech RAL za příplatek, ostatní barevné varianty na vyžádání.

Instalace

mřížek základní řady se provádí pomocí upevňovacích rámečků na potrubí nebo na stěnu. Výška instalace 2,5–3,5 m

Montáž

standardně dle montážních pružin. Na přání mřížky s předvrtanými otvory pro šrouby, upevnění pomocí magnetů nebo nastavitelných svorníků.

Příslušenství

Plenum boxy z pozinkované oceli, standardní nebo izolované. Regulační klapka R1 vyrobená z pozinkované oceli opatřená regulačními listy s protiběžnými pohybem. Pozední rámečky z pozinkovaného ocelového plechu.

ŠxV mm	VKE-V-1.0 VKE-H-1.0	VKE-V-2.0 VKE-H-2.0	VKx-R1	VKx-PR	PBZ-V	PBZI-V	PBZ-H	PBZI-H
200x100	•	•	•	•	•	•	•	•
300x100	•	•	•	•	•	•	•	•
400x100	•	•	•	•	•	•	•	•
500x100	•	•	•	•	•	•	•	•
600x100	•	•	•	•	•	•	•	•
700x100	•	•	•	•	•	•	•	•
800x100	•	•	•	•	•	•	•	•
1000x100	•	•	•	•	•	•	•	•
200x150	•	•	•	•	•	•	•	•
300x150	•	•	•	•	•	•	•	•
400x150	•	•	•	•	•	•	•	•
500x150	•	•	•	•	•	•	•	•
600x150	•	•	•	•	•	•	•	•
700x150	•	•	•	•	•	•	•	•
800x150	•	•	•	•	•	•	•	•
1000x150	•	•	•	•	•	•	•	•
200x200	•	•	•	•	•	•	•	•
300x200	•	•	•	•	•	•	•	•
400x200	•	•	•	•	•	•	•	•
500x200	•	•	•	•	•	•	•	•
600x200	•	•	•	•	•	•	•	•
700x200	•	•	•	•	•	•	•	•
800x200	•	•	•	•	•	•	•	•
1000x200	•	•	•	•	•	•	•	•
300x300	•	•	•	•	•	•	•	•
400x300	•	•	•	•	•	•	•	•
500x300	•	•	•	•	•	•	•	•
600x300	•	•	•	•	•	•	•	•
700x300	•	•	•	•	•	•	•	•
800x300	•	•	•	•	•	•	•	•
1000x300	•	•	•	•	•	•	•	•
400x400	•	•	•	•	•	•	•	•
500x400	•	•	•	•	•	•	•	•
600x400	•	•	•	•	•	•	•	•
700x400	•	•	•	•	•	•	•	•
800x400	•	•	•	•	•	•	•	•
1000x400	•	•	•	•	•	•	•	•
500x500	•	•	•	•	•	•	•	•
600x500	•	•	•	•	•	•	•	•
800x500	•	•	•	•	•	•	•	•
1000x500	•	•	•	•	•	•	•	•

• dodávané typy a rozměry

Typový klíč pro objednávání

V K E V - 1,0 - X 600 x 500 RAL 9010

- 1 – V – vertikální listy, H – horizontální listy
 2 – 1.0 – jednořadá, 2.0 – dvouřadá
 3 – typ upevnění
 bez uvedení = standard (pružiny),
 doplnit objednávkový kód o PR.
 1 – šrouby, 2 – magnety, 3 – svorníky
 4 – rozměry (mm)

- 5 – barva
 bez uvedení – transparentní elox,
 RAL 9010, 9016 nebo 7035,
 ostatní na vyžádání

Příslušenství

regulace

V K x - R 1 600 x 300

1 – rozměry (Š x V) (mm)

pozední rámeček

V K x - P R 600 x 300

1 – rozměry (Š x V) (mm)

VKE – komfortní přívodní/odvodní vyústky

Vysvětlivky:

- VKE-V-1.0 vyústka komfortní jednořadá vertikální
 VKE-H-1.0 vyústka komfortní jednořadá horizontální
 VKE-V-2.0 vyústka komfortní dvouřadá vertikální (přední listy vertikální, zadní horizontální)
 VKE-H-2.0 vyústka komfortní dvouřadá horizontální (přední listy horizontální, zadní vertikální)

Příslušenství:

- R1 regulační klapka R1
 PR pozední rámeček
 PBZ plenum box
 PBZI plenum box izolovaný

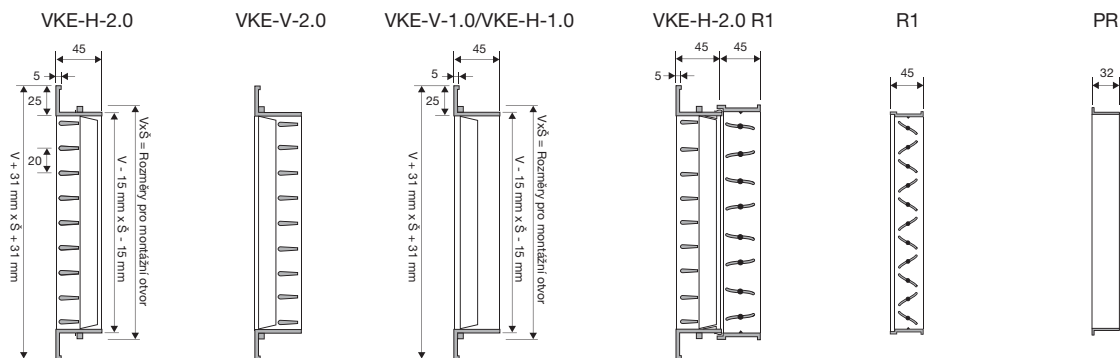

rozměry

Doplňující vyobrazení

Způsob montáže

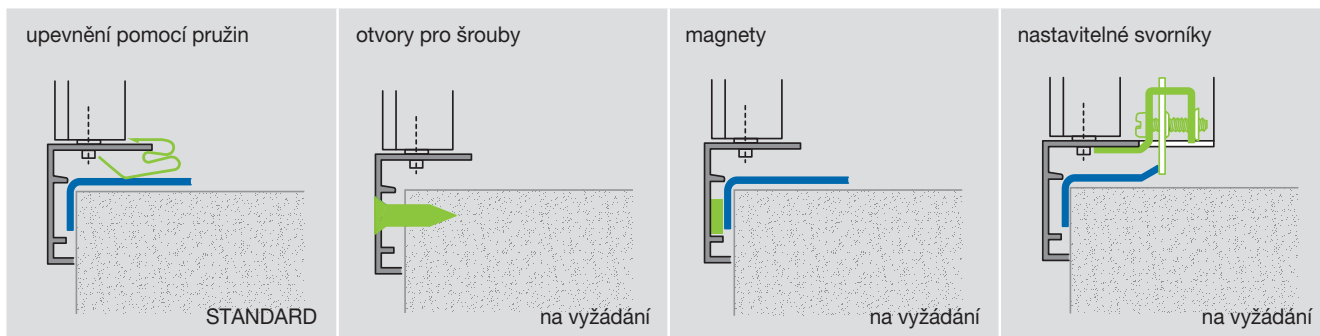

Poznámka
 Pro tento způsob montáže je nutné použít pozední rámeček VKx-PRs

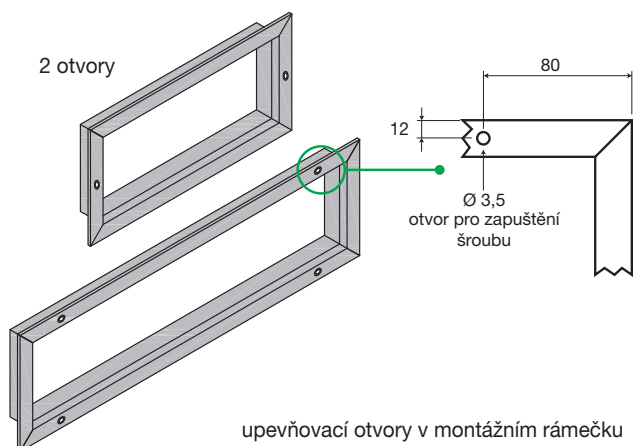
Počet otvorů pro montážní šrouby

V – kratší strana	Š – delší strana				
	200	250	300	350	≥400
100	2	2	2	4	4
150	2	2	2	4	4
200	2	2	2	4	4
≥250	2	2	2	4	4

Tabulka rychlého návrhu

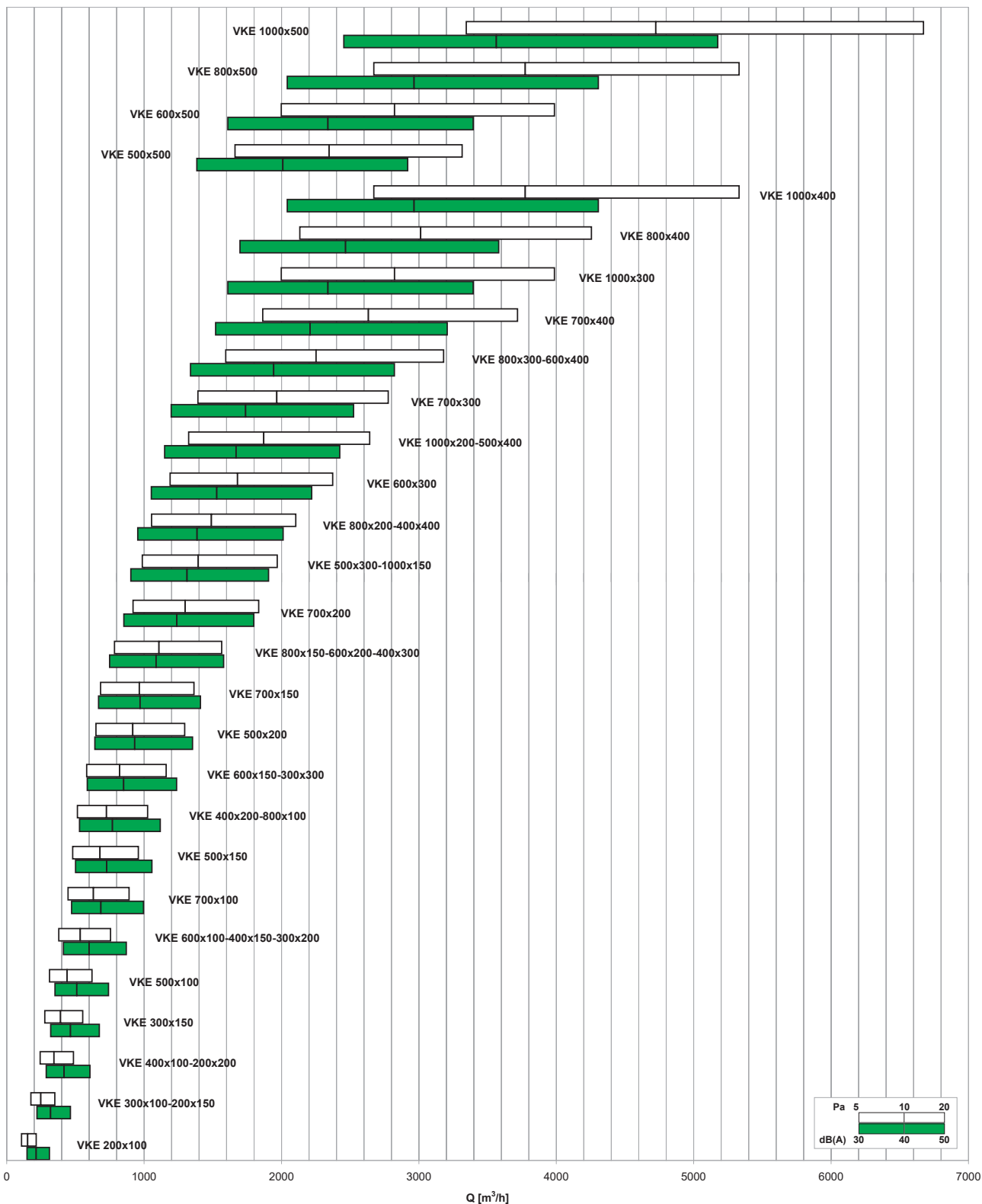

7²

VKE – komfortní přívodní/odvodní vyústky

Typ	A _k [m ²]	Q [m ³ /h]		L _{wa} [dB(A)]		X _{0,25} [m]		Δp _i [Pa]	
		min	max	min	max	min	max	min	max
VKE 200x100	0,0088	110	220	22	41	2,4	4,8	5	20
VKE 300x100/200x150	0,0144	180	350	25	42	3,1	6,0	5	20
VKE 400x100/200x200	0,0200	240	490	25	44	3,5	7,2	5	20
VKE 300x150	0,0228	280	550	26	45	3,8	7,5	5	20
VKE 500x100	0,0256	310	620	27	45	4,0	8,0	5	20
VKE 600x100/400x150/300x200	0,0311	380	760	28	46	4,5	8,9	5	20
VKE 700x100	0,0367	450	890	29	47	4,9	9,6	5	20
VKE 500x150	0,0395	480	960	29	47	5,0	10,0	5	20
VKE 400x200/800x100	0,0423	510	1030	29	48	5,1	10,4	5	20
VKE 600x150/300x300	0,0479	580	1160	30	48	5,5	11,0	5	20
VKE 500x200	0,0534	650	1300	30	49	5,8	11,6	5	20
VKE 700x150	0,0562	680	1360	30	49	5,9	11,9	5	20
VKE 800x150/600x200/400x300	0,0646	780	1570	31	50	6,3	12,8	5	20
VKE 700x200	0,0757	920	1830	32	50	6,9	13,8	5	20
VKE 500x300/1000x150	0,0813	990	1970	32	51	7,2	14,3	5	20
VKE 800x200/400x400	0,0869	1050	2100	33	51	7,4	14,7	5	20
VKE 600x300	0,0980	1190	2370	33	52	7,9	15,7	5	20
VKE 1000x200/500x400	0,1092	1320	2640	34	52	8,3	16,5	5	20
VKE 700x300	0,1147	1390	2780	34	53	8,5	17,0	5	20
VKE 800x300/600x400	0,1315	1590	3180	35	53	9,1	18,1	5	20
VKE 700x400	0,1537	1860	3720	35	54	9,8	19,6	5	20
VKE 1000x300	0,1649	2000	3990	36	54	10,2	20,3	5	20
VKE 800x400	0,1760	2130	4260	36	55	10,5	21,0	5	20
VKE 1000x400	0,2206	2670	5330	37	56	11,8	23,5	5	20
VKE 500x500	0,1370	1660	3320	35	53	9,3	18,6	5	20
VKE 600x500	0,1649	2000	3990	36	54	10,2	20,3	5	20
VKE 800x500	0,2206	2670	5330	37	56	11,8	23,5	5	20
VKE 1000x500	0,2764	3340	6670	38	57	13,1	26,2	5	20

Vysvětlivky:

Q [m ³ /h]	průtok vzduchu
A _k [m ²]	volná výtoková plocha
Δp _i [Pa]	celková tlaková ztráta
L _{wa} [dB(A)]	akustický výkon
X _{0,25} [m]	dosah proudu vzduchu pro získání komfortní rychlosti vzduchu v obytné zóně 0,25 m/s

SONOFLEX® MI

Ohebná Al laminátová hadice s vnitřním uspořádáním jako Aluflex MI, s tepelnou a hlukovou izolací z vrstvy ekologické nedráždivé minerální vaty tloušťky 25 mm, 16 kg/m³, parozábrana – zpevněný Al laminát. Vnitřní hadice je perforovaná jako tlumič hluku.

Výpočet poloměru ohybu (mm):

$$R = 0,6 D \text{ [mm]}$$

Konstrukce obsahuje parotěsnou zábranu k zbránění kondenzace v hlukové izolaci.

- silné snížení hlučnosti u větracích a klimatizačních zařízení a u tepelných čerpadel
- standardní délka 10 m (v kartonu stlačeno na 1,1 m)
- průměr 82–630 mm, tl. vnitřní vrstvy 0,070 mm
- max. rychlost vzduchu 30 m/s
- provozní teplota -30–150 °C
- tlakové ztráty viz další dvojstrana
- příslušenství na konci kapitoly a dále ceník Elektrodesign
- k dostání ekonomické provedení SONOFLEX® (tl. vnitřní vrstvy 0,045 mm)

Řada průměrů [mm]

82 102 127 152 160 185 203 229 254 305 315 356 406 457 508 560 630

SONOFLEX® MO

Velmi odolná ohebná Al laminátová hadice s vnitřním uspořádáním jako Aluflex MO, s tepelnou a hlukovou izolací z vrstvy ekologické nedráždivé minerální vaty tloušťky 25 mm, 16 kg/m³, parozábrana – zpevněný Al laminát. Vnitřní hadice je perforovaná jako tlumič hluku.

Výpočet poloměru ohybu (mm):

$$R = 0,6 D \text{ [mm]}$$

Konstrukce obsahuje parotěsnou zábranu k zbránění kondenzace v hlukové izolaci.

- silné snížení hlučnosti u větracích a klimatizačních zařízení a u tepelných čerpadel
- standardní délka 10 m (v kartonu stlačeno na 1,1 m)
- průměr 82–630 mm, tl. vnitřní vrstvy 0,074 mm
- max. rychlost vzduchu 30 m/s
- provozní teplota -30–250 °C
- tlakové ztráty viz další dvojstrana
- příslušenství na konci kapitoly a dále ceník Elektrodesign

Řada průměrů [mm]

82 102 127 152 160 185 203 229 254 305 315 356 406 457 508 560 630

**Vložený útlum v dB
vztaheno na 1 m hadice typ SONOFLEX, síla izolace 25 mm****Frekvence Hz**

Ø mm	63	125	250	500	1000	2000	4000	8000
80	13,5	22,5	29,0	24,0	19,0	14,0	17,5	11,0
102	12,5	21,0	27,0	22,5	17,5	13,0	16,5	10,0
127	11,5	19,0	25,0	20,5	16,0	12,0	15,0	9,0
152	10,5	17,5	23,0	19,0	15,0	11,0	14,0	8,5
160	10,5	17,5	23,0	19,0	15,0	11,0	14,0	8,5
203	9,0	16,0	21,0	17,5	13,5	10,0	12,5	8,0
254	8,5	15,0	19,0	16,0	12,5	9,0	11,5	7,0
315	7,5	13,5	17,5	14,5	11,0	8,0	10,5	6,0
406	7,0	12,0	15,5	13,0	10,0	7,5	9,5	5,0
508	6,5	10,5	14,0	11,5	9,0	6,5	8,0	5,0

Toleranční pole: ±5 dB

METALFLEX®

Polotuhá ohebná hadice z korozi-vzdorné oceli 1.4404 (ČSN 10088-1) AISI 316L.

- pro mechan. větrací a klimatická vedení
- pro odtahy kouře a prachu
- jako komínové vložky

- silně mechanicky odolná
- barva přírodní
- příslušenství – nerezová spojka METAL ve stejných rozměrech, viz. ceník Elektrodesign

Řada průměrů [mm]

80 100 125 150 160 180 200 250 300 350 400 450