

A - A

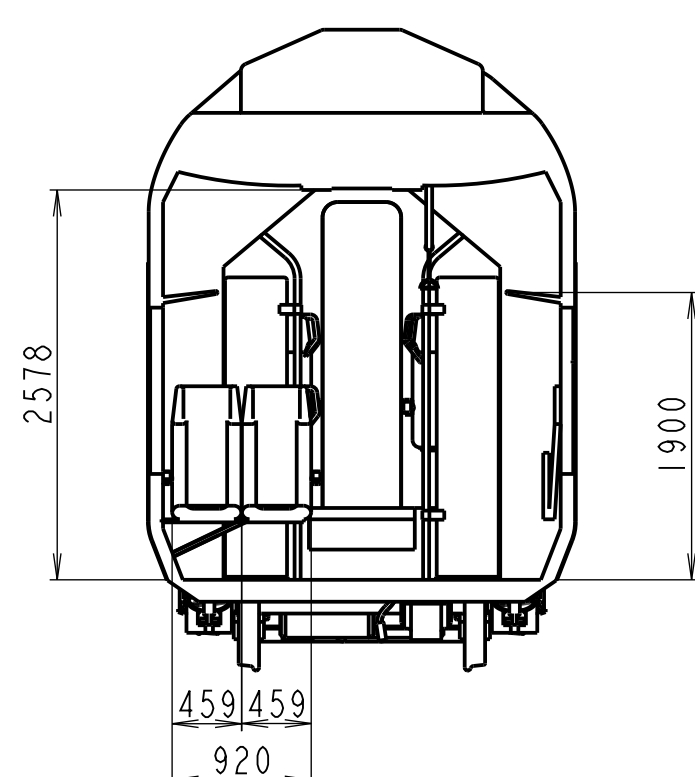

B - B

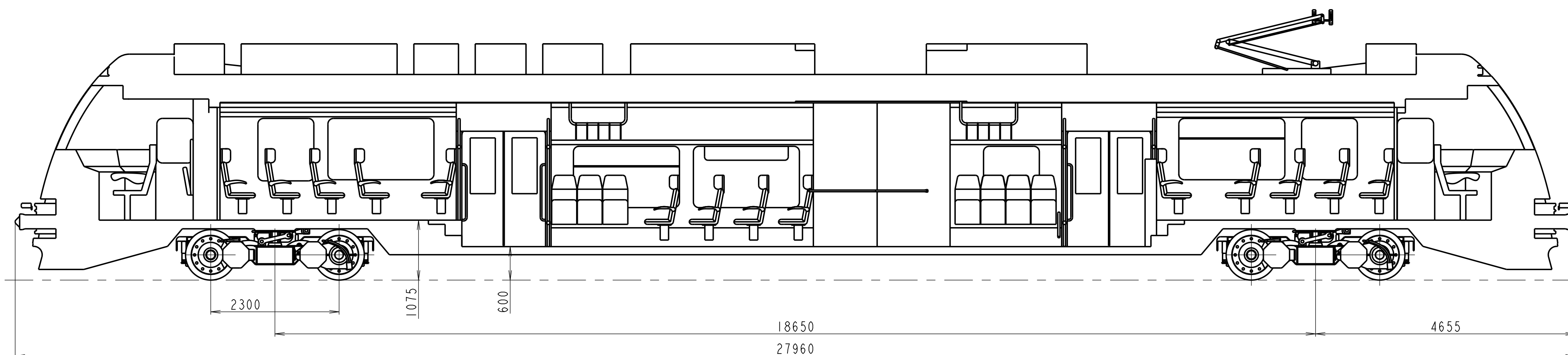
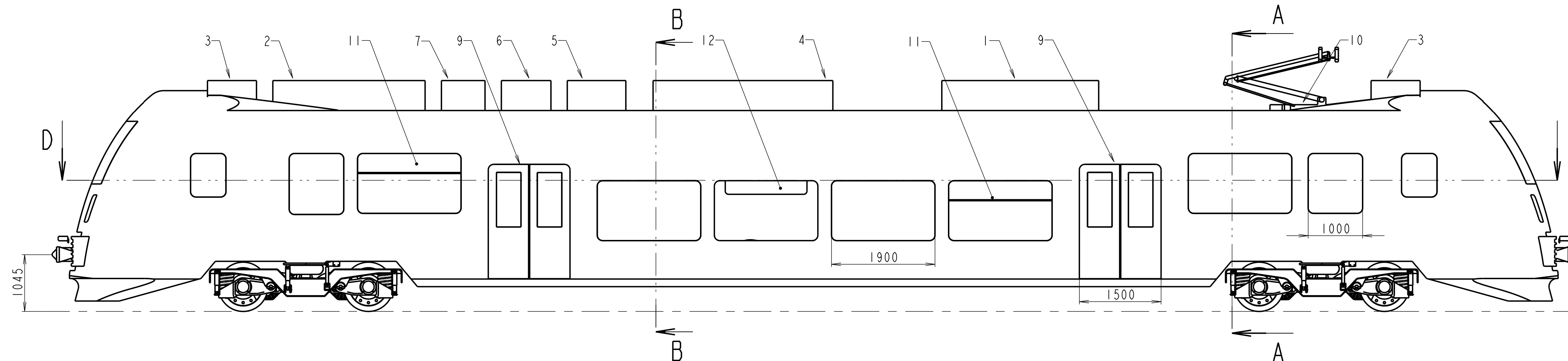

C - C

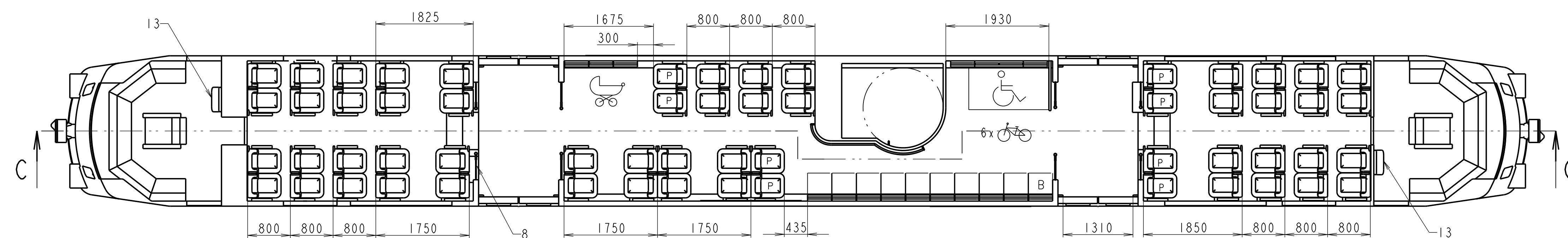

D - D

POZICE	NÁZEV	POZICE	NÁZEV		
1	TRAKCNI TRANSFORMATOR	12	INFORMACNI PANEL	Max. rychlost [km/h]	160
2	TRAKCNI MENIC	13	POMOCNE SEDADLO	Sedadel celkem	75
3	KLIMATIZACE STROJVEDOUCI			Z toho vyhrazenych zn.P	8
4	KLIMATIZACE CESTUJICI			Z toho klapcich sedadel	17
5	KOMPRESORMODUL			Pocet stojicich c. na m2	4
6	BRZDOVY ODPORNIK			Pocet stojicich cestujicich	80
7	POMOCNY MENIC			Celkova kapacita vozu	155
8	SKRINKA NOUZ. SPRAHLO			Plocha ke stani vctne schodu	20
9	DVOUKRIDLE DVERE			Mist pro invalidni vozik	1
10	SBERAC			Hmotnost plneho vozu	66,385t
11	OKNO - NOUZOVE VETRANI			Rozchod	1435 mm

3kV/DC - 25kV/50Hz

Podpis	Datum	Podpis	Datum	HMOTNOST	66 385 kg	MERITKO	150
NAVRHL	Petr Hryz	STATIK		WROTIKUM		C. SVITKU	
KRESLIL	07.06.2018	NORM. REF.		SESTAVA		KUSOVNIK	
SKUPINAR		PREKNOSEL		STARY V.			
TECHNOLOG		SCHVALIL					

TRAKCNI VUZ REGIONALNI V1
 FAKULTA STROJNI
 CÍSLO VÝKRESU
 TYP: