

ROZSAH PRACOVNÍHO PROSTORU ROBOTU
(1:5)

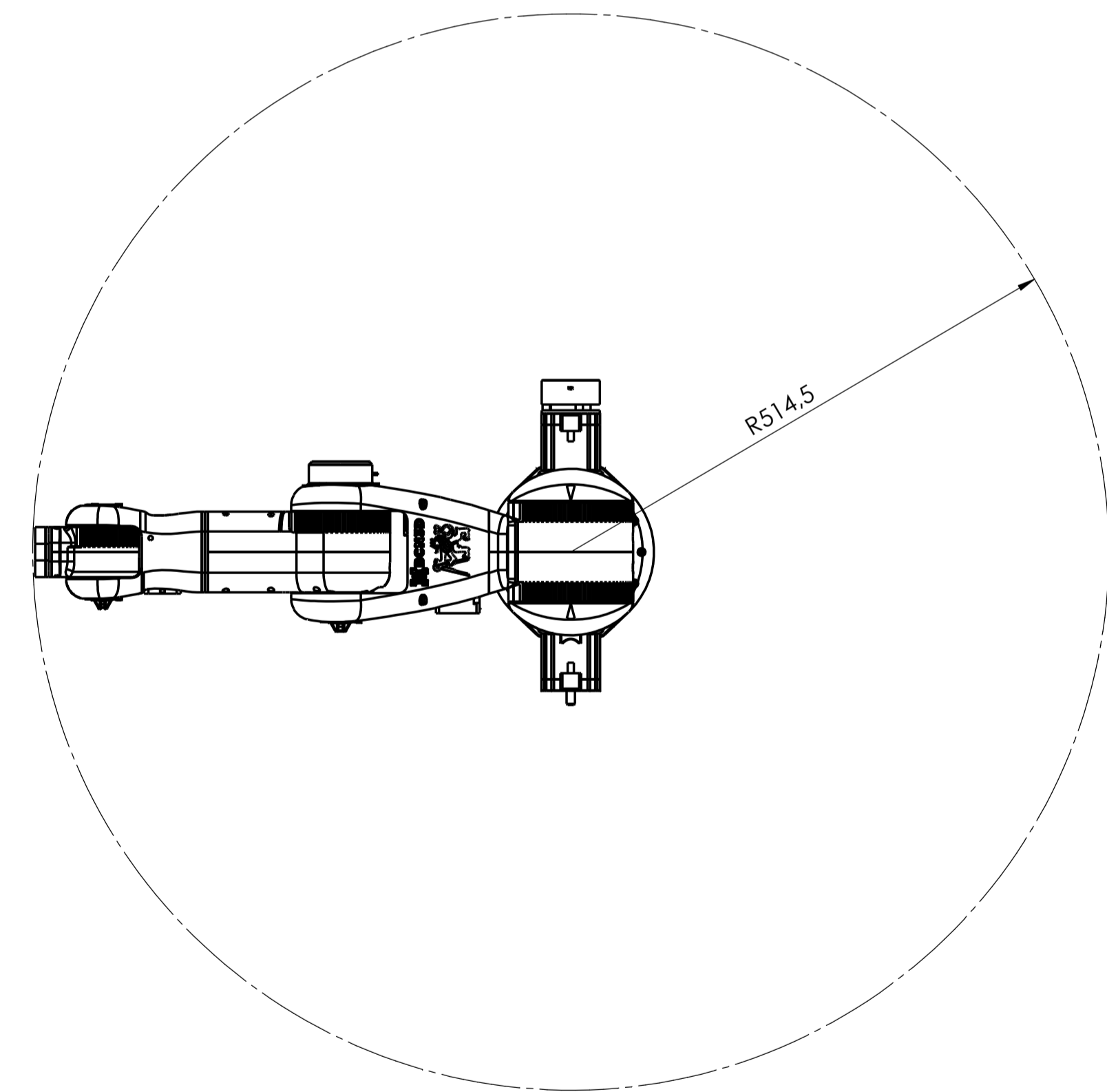
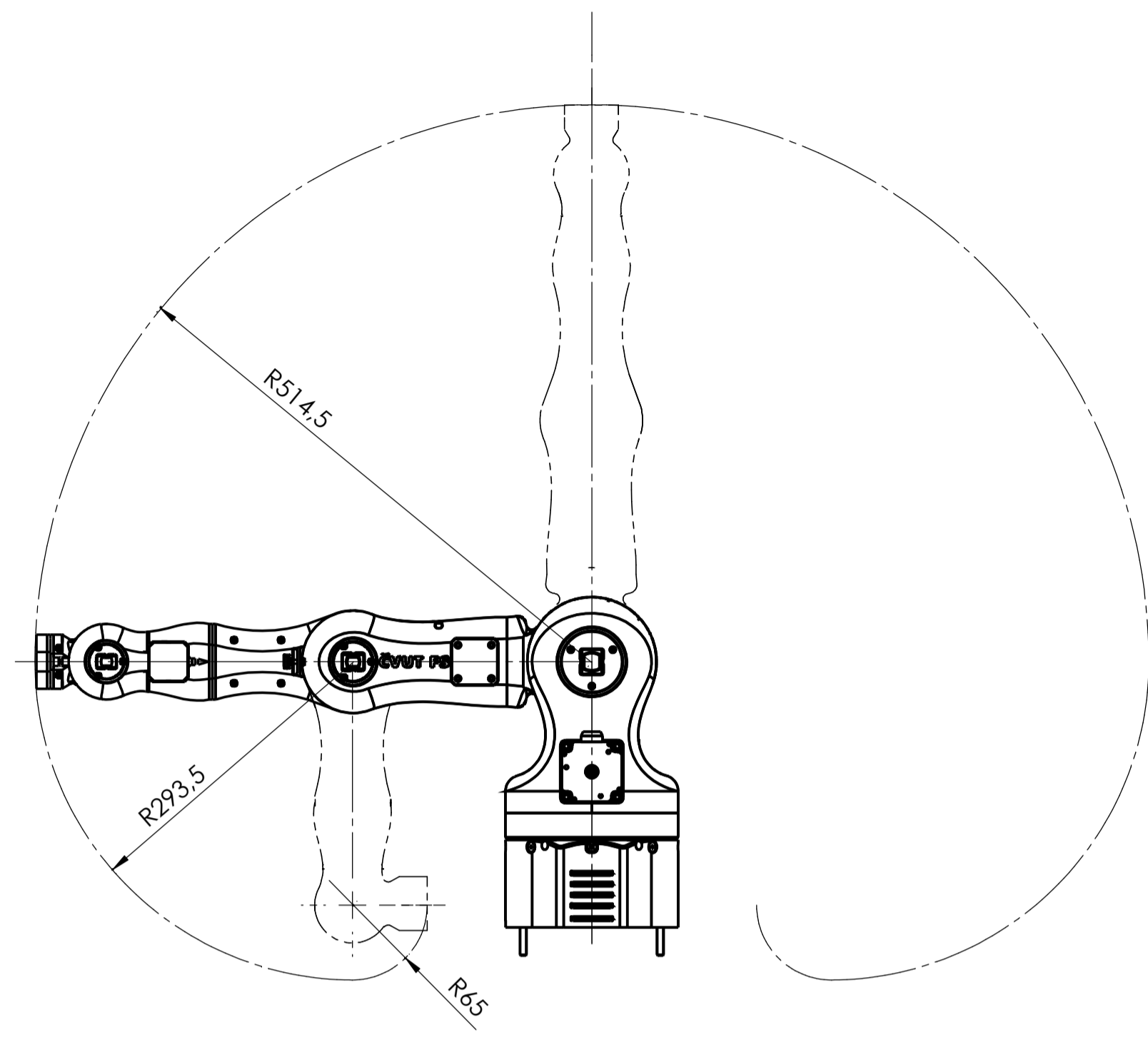

NAVRH	Autor	Datum	PŘETV.	Podoba	Datum	HMŮTNOST	8,6	kg	WĚŘÍTKO	1:2 (1:5)
KRESLIL	TOMÁŠ HAVLAN	28.6.2018	SCHVÁLIL			ESTÁVA			KUŠOVNÍK	1742-00-00-K
TECHNOL.						STAVY V.				
ČESKÉ VYSOKÉ UČENÍ TECHNICKÉ V PRAZE						NÁZEV		ROBOT BCN3D MOVEO		
FAKULTA STROJNÍ						ČÍSLO VÝKRESU		1742-00-00		
						TYP				