

CZECH TECHNICAL UNIVERSITY IN PRAGUE

FACULTY OF CIVIL ENGINEERING

DEPARTMENT OF STEEL AND TIMBER STRUCTURES

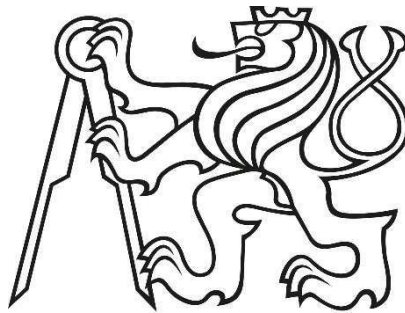

DIPLOMA THESIS

Possibilities of using HSS in truss beams – a parametric study

TECHNICAL REPORT

Name: Bc. Nina Feber

Adviser: doc. Ing. Michal Jandera, Ph.D.

Prague 2018



ZADÁNÍ DIPLOMOVÉ PRÁCE

I. OSOBNÍ A STUDIJNÍ ÚDAJE

Příjmení: Feber Jméno: Nina Osobní číslo: 406452

Zadávací katedra: Katedra ocelových konstrukcí, K134

Studijní program: Stavební inženýrství

Studijní obor: Konstrukce pozemních staveb

II. ÚDAJE K DIPLOMOVÉ PRÁCI

Název diplomové práce: Posibilities of using HSS in truss beams - a parametric study

Název diplomové práce anglicky: Posibilities of using HSS in truss beams - a parametric study

Pokyny pro vypracování:

Design of main load-bearing steel members for a selected part of Nexen building with the main focus on truss beams and their details. These beams will be designed by using various strength of steel and a most economical option will be evaluated. A parametric study is expected, mainly showing the influence of span, height and load on suitability of using high strength steel.

Drawing documentation (approx 1:200) is expected including also selected details (1:10). Technical report and brief summary of HSS benefits is also part of the project.

The thesis will be written in English.

Seznam doporučené literatury:

Eurokód 1 a 3

Publikace k optimalizaci ocelových konstrukcí s využitím vysokopevnostních ocelí prezentované zejména Tampere University of Applied Sciences

Jméno vedoucího diplomové práce: Michal Jandera

Datum zadání diplomové práce: 3.10.2017 Termín odevzdání diplomové práce: 7.1.2018

Podpis vedoucího práce

Podpis vedoucího katedry

III. PŘEVZETÍ ZADÁNÍ

Beru na vědomí, že jsem povinen vypracovat diplomovou práci samostatně, bez cizí pomoci, s výjimkou poskytnutých konzultací. Seznam použité literatury, jiných pramenů a jmen konzultantů je nutné uvést v diplomové práci a při citování postupovat v souladu s metodickou příručkou ČVUT „Jak psát vysokoškolské závěrečné práce“ a metodickým pokynem ČVUT „O dodržování etických principů při přípravě vysokoškolských závěrečných prací“.

12. 10. 2017

Datum převzetí zadání

Podpis studenta(ky)

Anotace

Diplomová práce obsahuje návrh nosné ocelové konstrukce jednoho dilatačního celku projektu NEXEN Tire. Dilatační celek se skládá z dvoulodní výrobní haly a skeletové konstrukce kancelářských prostor. Práce je rozdělena na dvě části. První je detailní návrh jednotlivých prvků ocelové konstrukce z oceli S355, včetně posouzení přípojů. K této části je rovněž vytvořena výkresová dokumentace. Druhá část je návrh ocelového nosníku o rozponu 28 metrů s použitím vysokopevnostních ocelí (S460 a S690), porovnání s původním návrhem, sestavení hybridního příhradového nosníku a vyhodnocení nejvýhodnější varianty. Na závěr je provedena parametrická studie, jejímž účelem je stanovit ekonomicky výhodné podmínky použití vysokopevnostní oceli s ohledem na rozpon či velikost zatížení.

Klíčová slova: příhradový vazník, vysokopevnostní ocel, ocelová hala

Abstract

The diploma thesis contains design of a load-bearing steel structure of one expansion unit of the NEXEN Tire project. The dilatation unit consists of a two-bay production hall and two storey office space. The thesis is divided into two parts. The first gives a detailed design of individual elements of steel construction from S355 steel, including the verification of connections (drawing part is drawn to this part). The second part contains design of 28 meters steel truss using high strength steel (S460 and S690) and a comparison to the previous design, hybrid truss design and evaluation of the most advantageous variant. Finally, a parametric study is done to show economical advantages of the high strength steel use in respect to the span or load magnitude.

Key words: truss, high strength steel, steel hall

Prohlášení:

Prohlašuji, že jsem předloženou práci vypracovala samostatně a že jsem uvedla veškeré použité informační zdroje v souladu s Metodickým pokynem o etické přípravě vysokoškolských závěrečných prací. Dále prohlašuji, že tato bakalářská práce nebyla využita k získání jiného či stejného titulu.

Declaration:

I declare that I have produced the submitted thesis independently and that I have provided all the information resources used in accordance with the Methodological Guideline on the Ethics of Higher Education Final Works. I further declare that this thesis was not used to obtain another or the same degree.

3. January 2018





Table of Contents

1. Basic information about the construction	2
2. Used standards	2
3. Description of the structure	2
4. Structural design procedures	3
5. Materials.....	3
6. Fabrication.....	3
7. Assembling of the structure on the site	3
8. Corrosion protection	4
9. Fire resistance	4
10. References.....	4
11. List of documents	4

1. Basic information about the construction

The subject of the design is one dilatation unit of production hall Nexen TIRE in the Ústecký kraj near town Žatec, Czech Republic. Object has one or two floors. Maximum height of the object is 12,4 m. Build up area is 9044 m². Object is located in an industry zone, altitude of this place is 372 meters. In the building are integrated offices, production facilities and development areas. The construction of the object is a steel or steel and concrete composite frame. Foundations of the structure are concrete piles. The envelope of the building is light-weight steel cladding wall system.

2. Used standards

The static calculation is carried out according to the European standards. The specific numbers and names of the standards are listed below.

—EN 1993-1-1, Eurocode 3: Design of steel structures - Part 1-1: General rules and rules for buildings

—EN 1993-1-3, Eurocode 3: Design of steel structures - Part 1-3: General rules - Supplementary rules for cold-formed members and sheeting

—EN 1991-1-1, Eurocode 1: Actions on structures - Part 1-1: General actions - Densities, self-weight, imposed loads for buildings

—EN 1991-1-3, Eurocode 1: Actions on structures - Part 1-3: General actions - Snow loads

—EN 1991-1-4, Eurocode 1: Actions on structures - Part 1-4: General actions –Wind loads

—EN 1993-1-8, Eurocode 3: Design of steel structures - Part 1-8: Design of joints

—EN 1993-1-12, Eurocode 3: Design of steel structures - Part 1-12: Additional rules for the extension of EN 1993 up to steel grades S 700

—EN 1090-1-A1, Execution of steel and aluminum structures – Part 2: Technical requirements for steel structures

3. Description of the structure

The building is 840 meters long. In the transverse direction, the object is usually 87 meters wide, maximum width is 110 meters. Building is divided into 7 dilatation units. Maximum length of the dilatation unit is 120 meters. Apart from these seven major units, there are also other special



dilatations units as a storage areas and machines, which create dynamic load for the unit. In this diploma thesis, there is designed one of the seven dilation units only.

The facility typically consists of two-bay hall of 28 m span. The production hall is adjacent to a four-bay two storey administrative section with a span of typically 7m and 9 m.

The production hall is roofed with steel trusses made of hollow cross-section profiles, with a spacing of 7 m between each other. Trusses are simply supported by steel columns of HEA profile.

The roofing is a load-bearing trapezoidal sheet spanned between the main frames.

Underneath machinery, which generates dynamic loads on building structures are designed separate foundations.

Stiffness in the lateral direction provided by vertical wall bracing.

4. Structural design procedures

The supporting structures were designed according to the Eurocodes, namely EN 1993-1-1 and EN 1993-1-8 which was used for design and verification of connections. For calculation of internal forces was used software Dlubal RFEM and software IDEA StatiCa for verification of connections. The load was calculated in accordance with EN 1991.

5. Materials

The main elements of the steel structure are designed from S355JR steel or steel of similar properties in terms of toughness, the base are designed from S355J2 steel. The used bolts are class 8.8 for common connections, 10.9 for the lower chord bolted connection of the truss and 8.8 and 5.8 for anchors. Reinforced concrete blocks are made of C20 / 25 concrete.

6. Fabrication

Execution class is EXC2 for consequence classes CC2 ([Medium consequence) and service category SC1 (constructors / components designed for quasi actions only, eg buildings). The steel structure will be manufactured according to the provided documentation, which is prepared by the steel contractor.

7. Assembling of the structure on the site

The individual assembly element are bolted. Bolts are 10.9 and 8.8. Each column, purlin, stiffener is a special mounting piece. The storage truss is composed of 3 mounting parts with a length of max.

9.5m, and is the largest mounting part of the weight 1408 kg (column HEA340). In the first phase of assembly, the columns are positioned on the pre-set points for the positioning of the base plates according to the anchor plan. The trusses will be placed on the columns without any temporary support. Subsequently, the trusses will be connected to the individual frames by bolts. During assembling the structure, the elements must not be damaged or deformed above the permissible tolerances. The weight of the entire structure is 398,45 t.

8. Corrosion protection

The load-bearing structure is sheltered by cladding and roofing. It has a medium degree of corrosive aggressiveness (C2) and a high lifespan (over 15 years). The paint system will be used for corrosion protection of steel structures.

9. Fire resistance

Fire resistance of construction is not subject of a diploma thesis. Steel structures are designed with R15 resistance without the need for fire coatings or tiles. However, a verification of the resistance would be needed.

10. References

The following resources were used for the thesis.

— Zdeněk Sokol, František Wald. Ocelové konstrukce: tabulky. 2., přeprac. vyd. V Praze: České vysoké učení technické, 2010,

— Tomáš Vraný, Michal Jandera, Martina Eliášová. 2009. Ocelové konstrukce 2: cvičení. Vyd. V Praze: České vysoké učení technické, 2010,

— Wald, František, Josef Macháček, Michal Jandera, Zdeněk Sokol, Jakub Dolejš, Radek Hájek: Structural Steel Design According to Eurocodes, Vyd. 1. 05/2012, v Praze, České vysoké učení technické

11. List of documents

- 1) Technical report
- 2) Diploma thesis
- 3) Appendix
- 4) Drawing documentation

CZECH TECHNICAL UNIVERSITY IN PRAGUE

FACULTY OF CIVIL ENGINEERING

DEPARTMENT OF STEEL AND TIMBER STRUCTURES

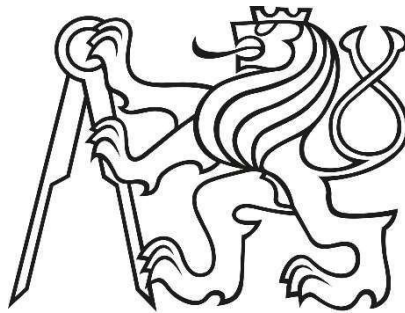

DIPLOMA THESIS

Possibilities of using HSS in truss beams – a parametric study

STATIC CALCULATION

Name: Bc. Nina Feber

Adviser: doc. Ing. Michal Jandera, Ph.D.

Prague 2018



ZADÁNÍ DIPLOMOVÉ PRÁCE

I. OSOBNÍ A STUDIJNÍ ÚDAJE

Příjmení: Feber Jméno: Nina Osobní číslo: 406452

Zadávací katedra: Katedra ocelových konstrukcí, K134

Studijní program: Stavební inženýrství

Studijní obor: Konstrukce pozemních staveb

II. ÚDAJE K DIPLOMOVÉ PRÁCI

Název diplomové práce: Posibilities of using HSS in truss beams - a parametric study

Název diplomové práce anglicky: Posibilities of using HSS in truss beams - a parametric study

Pokyny pro vypracování:

Design of main load-bearing steel members for a selected part of Nexen building with the main focus on truss beams and their details. These beams will be designed by using various strength of steel and a most economical option will be evaluated. A parametric study is expected, mainly showing the influence of span, height and load on suitability of using high strength steel.

Drawing documentation (approx 1:200) is expected including also selected details (1:10). Technical report and brief summary of HSS benefits is also part of the project.

The thesis will be written in English.

Seznam doporučené literatury:

Eurokód 1 a 3

Publikace k optimalizaci ocelových konstrukcí s využitím vysokopevnostních ocelí prezentované zejména Tampere University of Applied Sciences

Jméno vedoucího diplomové práce: Michal Jandera

Datum zadání diplomové práce: 3.10.2017 Termín odevzdání diplomové práce: 7.1.2018

Podpis vedoucího práce

Podpis vedoucího katedry

III. PŘEVZETÍ ZADÁNÍ

Beru na vědomí, že jsem povinen vypracovat diplomovou práci samostatně, bez cizí pomoci, s výjimkou poskytnutých konzultací. Seznam použité literatury, jiných pramenů a jmen konzultantů je nutné uvést v diplomové práci a při citování postupovat v souladu s metodickou příručkou ČVUT „Jak psát vysokoškolské závěrečné práce“ a metodickým pokynem ČVUT „O dodržování etických principů při přípravě vysokoškolských závěrečných prací“.

12. 10. 2017

Datum převzetí zadání

Podpis studenta(ky)

Prohlášení:

Prohlašuji, že jsem předloženou práci vypracovala samostatně a že jsem uvedla veškeré použité informační zdroje v souladu s Metodickým pokynem o etické přípravě vysokoškolských závěrečných prací. Dále prohlašuji, že tato bakalářská práce nebyla využita k získání jiného či stejného titulu.

Declaration:

I declare that I have produced the submitted thesis independently and that I have provided all the information resources used in accordance with the Methodological Guideline on the Ethics of Higher Education Final Works. I further declare that this thesis was not used to obtain another or the same degree.

3. January 2018



Acknowledgements

I would like to thank doc. Ing. Michal Jandera, Ph.D for the insight and assistance of problems encountered in this diploma thesis. RUUKKI company, especially Ing. Jan Samec, Ph.D and Dan Pada, for support.

Anotace

Diplomová práce obsahuje návrh nosné ocelové konstrukce jednoho dilatačního celku projektu NEXEN Tire. Dilatační celek se skládá z dvoulodní výrobní haly a skeletové konstrukce kancelářských prostor. Práce je rozdělena na dvě části. První je detailní návrh jednotlivých prvků ocelové konstrukce z oceli S355, včetně posouzení přípojů. K této části je rovněž vytvořena výkresová dokumentace. Druhá část je návrh ocelového nosníku o rozponu 28 metrů s použitím vysokopevnostních ocelí (S460 a S690), porovnání s původním návrhem, sestavení hybridního příhradového nosníku a vyhodnocení nejvýhodnější varianty. Na závěr je provedena parametrická studie, jejímž účelem je stanovit ekonomicky výhodné podmínky použití vysokopevnostní oceli s ohledem na rozpon či velikost zatížení.

Klíčová slova: příhradový vazník, vysokopevnostní ocel, ocelová hala

Abstract

The diploma thesis contains design of a load-bearing steel structure of one expansion unit of the NEXEN Tire project. The dilatation unit consists of a two-bay production hall and two storey office space. The thesis is divided into two parts. The first gives a detailed design of individual elements of steel construction from S355 steel, including the verification of connections (drawing part is drawn to this part). The second part contains design of 28 meters steel truss using high strength steel (S460 and S690) and a comparison to the previous design, hybrid truss design and evaluation of the most advantageous variant. Finally, a parametric study is done to show economical advantages of the high strength steel use in respect to the span or load magnitude.

Key words: truss, high strength steel, steel hall



Table of Contents

Introduction	6
Part A	8
1. High strength steel	9
1.1. Available assortment	9
1.2. Steel type and process route	9
1.3. Chemical composition	10
1.4. Mechanical properties	11
1.5. Weldability	12
1.6. Cast steel	13
2. NEXEN TIRE project	14
Part B.....	16
3. Geometry	17
4. Loads	18
4.1. Permanent action.....	18
4.1.1. Self-weight.....	18
4.1.2. Other permanent loads	19
4.2. Variable actions.....	19
4.2.1. Imposed loads	19
4.2.2. Snow loads	19
4.2.3. Wind load – external pressure	21
4.2.4. Internal pressure	23
4.2.5. Frictional force	25
4.2.6. Summarization of wind loads.....	26
4.3. Load combinations.....	27
5. Internal forces	27
5.1. Columns	28
5.2. Truss	28
6. Roof	29



6.1.	Roof system without purlin.....	30
6.1.1.	Design of trapezoidal sheets. Distance between trusses is 5m	30
6.1.2.	Deflection	31
6.1.3.	Load capacity above support	31
6.1.4.	Bending moment.....	33
6.1.5.	Design of trapezoidal sheets. Distance between trusses is 7m	34
6.1.6.	Bending moment.....	36
6.2.	Roof system with purlin	37
6.2.1.	Design of trapezoidal sheet.....	38
6.2.2.	Design of purlin	39
6.3.	Summarization	41
7.	Cladding wall	41
8.	Preliminary truss design.....	41
8.1.	Material choice	41
8.2.	Conceptual choice.....	42
8.2.1.	Height choice (Geometry of the considered variants).....	43
8.3.	Loads combinations	44
8.4.	Preliminary verification in SCIA Engineer.....	45
8.5.	Statical model.....	46
8.5.1.	Hinged truss.....	46
8.6.	Final geometry of the reference truss	47
9.	Detailed truss design.....	47
9.1.	Global analysis.....	48
9.2.	Columns imperfection.....	48
9.3.	Imperfection for analysis of bracing systems	49
9.4.	Combination of used load cases	50
9.5.	Internal forces in the truss.....	51
9.6.	Truss members design S355.....	52
9.6.1.	Tensile members profile design	52
9.6.2.	Pressed vertical members' design.....	53



9.6.3.	Upper chord design	54
9.6.4.	Lower chord profile verification (in pressure).....	60
9.6.5.	Deflection	62
9.7.	Columns	63
9.7.1.	Outer column of the hall	63
9.7.2.	Inner columns of the hall	69
10.	Roof bracing	73
10.1.	Internal forces	73
10.2.	Bracing profile design.....	74
11.	Vertical roof bracing.....	77
11.1.	Internal forces	77
11.2.	Bracing profile design.....	77
12.	Wall bracing	79
12.1.	Internal forces	79
12.2.	Bracing profile design.....	79
13.	Design of administrative part.....	81
13.1.	Floor construction	81
13.1.1.	Loads	82
13.1.2.	Trapezoidal sheets.....	83
13.1.3.	Preliminary design of concrete slab	84
13.1.4.	Secondary beam (9m span).....	85
13.1.5.	Secondary beam (7m span).....	91
13.1.6.	Primary beam (inner)	93
13.1.7.	Primary beam (outer).....	97
13.2.	Roof construction.....	100
13.2.1.	Loads	100
13.2.2.	Design of the roof beams	100
13.3.	Columns	101
13.3.1.	Serviceability limit state	101



13.3.2.	Internal forces	102
13.3.3.	Buckling coefficients.....	103
14.	Connections.....	104
14.1.	Truss connection	104
14.1.1.	Upper chord connection	104
14.1.2.	Diagonal connection.....	106
14.1.3.	Plate weld to a column.....	108
14.2.	Diagonal members and upper chord joints	109
14.3.	Bolted connection on the lower chord	114
14.3.1.	Bolt resistance	115
14.3.2.	Prying action.....	116
14.4.	Bracing connection	117
14.4.1.	Plate weld to the column	119
14.5.	Secondary beam to a primary beam (column) connection	120
14.6.	Primary beam to a column connection.....	122
14.7.	Base plate of inner column	123
14.7.1.	Pressure load capacity of the base plate	124
14.7.2.	Welds.....	125
14.7.3.	Tensile and shear resistance of the anchors.....	126
14.8.	Base plate of outer column (with bracing)	126
14.8.1.	Bracing to base plate connection.....	128
Part C.....		130
15.	High strength steel truss design.....	131
15.1.	Truss members design S460.....	131
15.1.1.	Tensile members profile design	131
15.1.2.	Pressured members design	132
15.1.1.	Interaction factors.....	133
15.1.2.	Joints.....	136
15.2.	Truss members design S690.....	138



15.2.1. Tensile members profile design	138
15.2.2. Pressed truss members design.....	139
15.2.3. Interaction factors.....	140
15.2.4. Joints.....	143
15.3. Comparison and evaluation	145
Part D	149
16. Parametric study	150
16.1. Main parameters considered.....	150
16.2. Deflection.....	151
16.3. Member design	151
16.4. Comparison and evaluation	152
17. Conclusions	154
18. List of Figures	156
19. List of Tables.....	159
20. Bibliography	161



Introduction

The use of steel structures in civil engineering grows every year. Thanks to a significant load-bearing capacity, a high degree of industrial production and possible re-using of members, the reliability of joints, and a relatively low weight.

Thanks to modern calculation possibilities and market pressure to reduce prices, each construction design has to be optimized. The market environment is pushing down the cost of manufacturing, transporting and assembling steel constructions. At present, the price of steel construction does not depend only on the weight of the structure but also on many different factors such as:

- Production options
- Material strength (S355 to S700) and its combination.
- Truss height (ranging from approx. 1/16 to 1/12 span).
- Truss span
- Welds

Today, steels with yield strengths of 1100 MPa are available on the market. Even though high strength steel has been used as a structural material over decades, the most used materials exhibits significantly lower yield strengths. In Europe the use of high-strength steel is still limited mainly due to the lack of design rules, experience and availability on market or comparatively higher price of HSS.

The main advantages of high strength steel are the ability to reduce structure weight and size. Fewer parts mean also less welding (cost and cycle-time savings). Depending on structural use, the higher strength can result into better fatigue and crash performance, while maintaining or even reducing thickness.

The chart below compares the relative weights of steel trusses using steel of different strengths and their combinations. It is clear from the result that in certain cases it can be saved up to 25% of steel weight using the S700. Reduced member thickness or size can also save welding costs as well as fabrication, erection and transportation costs. The most economical and efficient use of HSS is in members loaded by tension and where dead load is the predominant load, whereas for members subjected to buckling the increased strength doesn't lead to significant savings of material. So, by using hybrid girders can be achieved more economical solution.

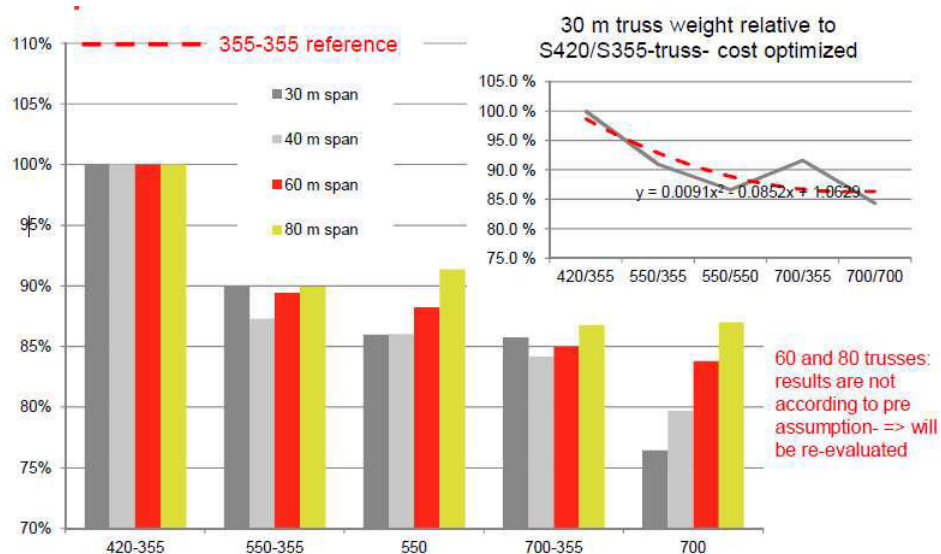

Figure 1.1-1 Relative weights of the trusses – KT- optimized [1]

At present the Eurocode distinguishes "common" steels with yield strength up to 460 MPa (EN 1993-1-1) and high strength steels up to the yield strength of 700 MPa (EN 1993-1-12). Steels with yield strength of more than 700 MPa are referred to as "very high strength steel".

Strength [MPa]	Description	Other descriptions	Typical examples
<460	Regular structural steel	Mild steel	S235
300-700	Conventional high strength steel	High performance steel/ High tensile steel	S355/S420/S460/S550/S690
700-1100	Very high strength steel (VHSS)	Ultra high strength steel/ Super high strength steel	S890/S960/S1100

Table 1.1-1 Available steel assortment

The aim of his study is to present the potential financial savings that high strength steels offer in case of long span truss. It will show whether HHS really finds application where it is necessary to reduce weight, not only for reasons of material cost savings, but also due to manufacturing, transport and erection costs.

In the following parts of this thesis the use of different strengths of steel is analyzed on an example of a truss to evaluate the most suitable solution.



Part A

Part A is a summary of the overview of high-strength steels based on scientific documents, previous studies and other relevant sites on the Internet. Also, there is information about the project NEXEN TIRE, where designed dilatation unit in part B is located.



1. High strength steel

The main difference between common mild steel or high strength steel is yield strength. Other mechanical properties such as Young's modulus of elasticity E , impact resistance are the same. Higher strength steels are usually produced by the quenching and tempering route. The use of HSS does not help to increase the bending stiffness, buckling strength or higher fatigue resistance. These circumstances do not allow full use of the yield strength of high strength steel. Design standard EN 1993-1-12 gives additional design rules only up to S700 steel grades. Therefore, for practical reasons this study focuses on the range of S460-S700, which are covered by the Eurocodes.

1.1. Available assortment

The manufacture and sale of high strength steel rolled bars and plate products mainly concerned by a large multinational companies. Arcelormittal supplies a relatively wide range of rolled bars in the HITSTAR 420, 460, and 500 grades. In particular, there are larger cross sections. Another important company, RUUKKI (Rautaruukki Corporation), offers wide range of plate and hollow section. Ruukki is a leader in the development of high-strength special steels and has been manufacturing Optim high-strength steels since 2002. Ruukki's manufacturing program includes the thinnest ultra-high-strength structural steels on the market. Another significant company that is involved in the production of high strength steel is SSAB Oxelösund. This Swedish company is part of the Svensk Stål Group and ranks among the leading manufacturers in the world. The new sophisticated technological processes for the production of high strength steel were produced and introduced by the company, thus shifting the development of steel in the world. At the same time, they were the first to introduce steel with a yield strength of 1100 MPa. Their production program in the high strength steel sector is affected by the WELDOX, DOMEX and HARDOX system series. Other European companies such as British Steel, Voest-Alpin, Dillinger Hütte are also involved in the production and distribution of HSS products.

1.2. Steel type and process route

In general, the strength of steel is controlled by its microstructure which varies according to its chemical composition, its thermal history and the deformation processes



it pass during its production schedule. Typically, two main ways are used to achieve higher yield strength:

- Alloying: carbon and manganese are among the major alloying elements. With these elements it's relatively easy to improve strength of steels, but they also adversely affect some of the utility properties such as weldability and impact resistance.
- Heat treatment: This steelmaking process change the material microstructure and grain size. The goal of this process is to achieve a finer microstructure, resulting is higher strength and toughness (compared to the material of the regular microstructure).

Currently, high strength steel is produced by controlled thermomechanical rolling (M) or quenching (Q) with stress relieving. Through these processes a fine-grained steel structure is achieved without higher alloying elements.

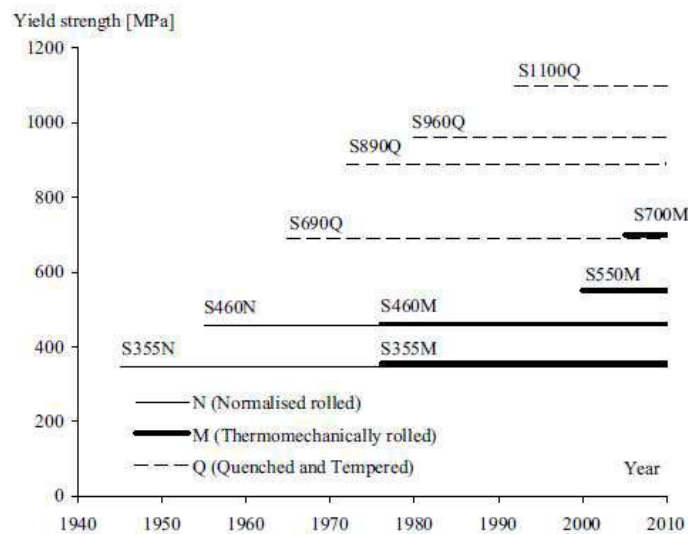

Figure 1.2-1 Historical development of rolled steel products [2]

1.3. Chemical composition

Thermomechanically rolled HSS has the same chemical composition as conventional steels. Most steels have the same or slightly increased carbon content as ordinary steels (approx. 0.2%). The most common alloying elements include manganese, chromium, silicon, copper, phosphorus, sulfur, nickel, molybdenum and others. Depending on the



material properties required for a specific application, the amount and types of alloying elements differ in chemical composition of HSS.

1.4. Mechanical properties

High strength steel has higher yield strength and ultimate strength than conventional steel. The stress-strain curve for steels is differs significantly between mild and high strength steels (see Figure 1.4-1 below). One should note here that the ratio of ultimate strength to yield strength of S700 is lower (about 1,06) than that of mild steels (this value ranges from 1,2 to 1,5).

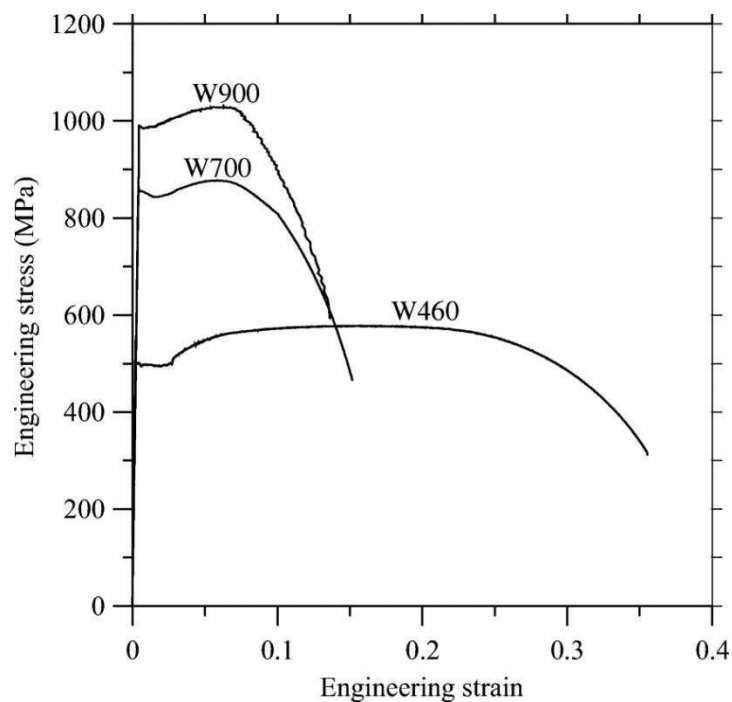

Figure 1.4-1 Stress-strain curves [2]

Ductility is a measure of degree of plastic deformation which has occurred prior to fracture. This is one of the properties that limit the use of high strength steel. Generally the ductility of HSS is lower than common steels.

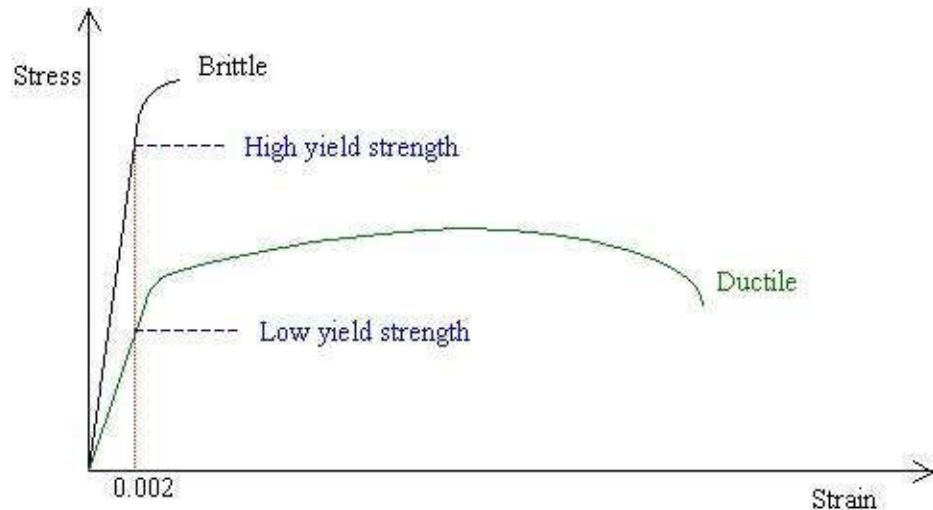

Figure 1.4-2 Yield strength and ductility [2]

- Modulus of elasticity (E) for all structural steels is approximately the same (considering 210 GPa). This may be a disadvantage for the high strength steel. In case where serviceability limit state is governing, there is no possibility to use the higher strength of the material.

1.5. Weldability

Weldability of steel is a term that is used to indicate the ease with which sound weldments can be produced using normal welding procedures. It is mainly influenced by its chemical composition. The influence of chemical composition on weldability can be characterized by carbon equivalents C_e , which expresses the contribution of alloying elements to the hardenability of the steel.

$$C_e = C + \frac{Mn}{6} + \frac{Cr + Mo + V}{5} + \frac{Ni + Cu}{15} \quad [\%]$$

Growing value C_e reduces weldability. Steels with very high carbon equivalent value indicate poor weldability, and are not suitable for structural applications. The carbon equivalent generally increases with a growing steel grade. Steel grades S420 have Carbon equivalents around 0,3%, S1100 grade steel around 0,6%. From these facts, one may conclude that high strength steels have worse weldability than mild steels. This doesn't mean that welding is not possible or welds of these steels are inferior to those of common mild steels. However, it is necessary to keep a more precise technological procedure for welding.



The main problem for high strength steels is cold cracking. Local stress concentrations or residual stresses from welding will increase the risk. The propensity of the steel to form cold cracks increases with the growing yield strength, the content of diffusion hydrogen in the weld, size of the welded parts, size of the welds, amount of introduced heat. The main technological measure to reduce the risk of cold cracks in welds is preheating. This causes a reduction in the rate of cooling of the weld, allowing the formation of structures more favorable to the diffusion of hydrogen. Preheating also reduces the temperature gradients during welding, which has a positive effect on the residual stresses in the welds.

1.6. Cast steel

The cost of steel is typically depend on a few factors, including the price of the raw material, the price of energy, and the supply-demand relationship for that specific type of steel. It is therefore, important to know the price of the entire steel package and not simply the cost of the material.

Material prices for HSS are currently higher than mild structural steel grades. However, the price is expected to decrease in the next few years as the market demands for high strength steel grades will increase.

Material costs will be calculated based on the self-weight of the steel structure only (steel members). Assuming that S460 and S690 is 10% and 20% respectively, more expensive per kg of steel, in comparison to S355. If for example, S355 costs 1.00 €/kg material then S460 costs 1,10 €/kg and S690 1,2 €/kg (average prices based on the actual inquiry of hollow-section in RUUKKI). It is important to note that in these prices are not included other important costs, like fabrication (e.g. welding costs), handling, transportation costs, etc. which obviously have a great influence on final total costs of the truss design.

Based on these assumptions, the HSS may be more suitable because the overall weight of the structure is lower. But after charging other costs, such as flame cutting, drilling, punching holes atc., the price for HSS can rise sharply in comparison to S355. These items are more expensive because high material strength requires extra tools. As far as welding is concerned, it may be a little more complicated. Since high strength steel requires higher welding quality, slower welding speeds and slower weld cooling. But at the same time the dimensions of the weld are smaller than the S355. For example,



welding of the S355 steel requires a weld of 5 mm thick, which the weld must do twice, but for high-strength steels, 4 mm thick weld will need to be made, but requires more care and more time. Thus, we can assume that the cost of welding work on the S355 and S700 will be the same.

Nowadays, fabrication and labor costs are the most costly part of construction. Designing, for example, for the lowest truss weight, does not usually offer the most economical solution.

Variability of assemblies is also very important. A large number of the same parts reduces the cost per kg of construction.

Thus, designing and detailing must be carried out always with respect to feasibility and constructability.

2. NEXEN TIRE project

South Korea's NEXEN Tire is one of the world's leading tire manufacturers. Its headquarters are located in Yangsan and South Korea's Seoul metropolis. NEXEN Tire is innovator in using up-to-date technology and new manufacturing processes. The first NEXEN Tire production plant outside the Asian continent will be erected in the Czech Republic - in the Triangle Industrial Zone near North Bohemian Žatec. The construction of a modern factory complex will commence in the first half of 2017, the start of production will commence in the second half of 2018.

Newly built NEXEN plant will produce passenger car tires. The new plant is designed as a production unit that includes a complex of all the necessary building structures, engineering networks and operational files that provide the necessary scope of the building and technological part of the project. The project manufactures tire for passenger cars.

For a simple orientation, the 100m² area project will be divided into individual building objects. In the following calculations, we will only consider the construction of the main fabrication hall.

The object is based on the underlying foundations of large-diameter reinforced concrete piles. The concrete floorboard is designed at several height levels. The vertical supporting structure consists prefabricated columns from reinforced concrete or steel columns, which are inserted into slots of the foundation piles. The roof structure of the

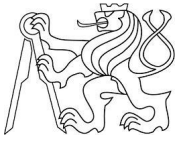

building is designed as a combination of steel trusses and prefabricated reinforced concrete girders.



Part B

In the part B is chosen and designed a dilatation unit from the NEXEN TIRE project included load calculation, profile dimensioning and design of selected connections.

First of all, 28 m span truss is designed, five options of the truss height are taken into consideration and finally is selected the most suitable static model. Then follows a detailed static design of truss profiles, columns and bracings. In chapter 13 the elements of the administrative part will be designed (administrative part is also part of chosen dilatation unit).

In conclusion, selected connections will be verified. For the whole dilatation unit is created drawing documentation (see attachments).



3. Geometry

The transversal dimension (width) of the building is typically 86 m, but in some places exceeds 110 m, and longitudinal amount is cca 830 m in total. The production line is single storey hall with typically two spans of 28 m and height around 12 m. Another 30 m section is than added along the northern edge, which is divided typically into three spans, double storey (10 m total height), include mostly offices, supporting facilities, energy supply units etc. Expansion of the factory is expected in the future, additional spans will be placed along the south edge of the building.

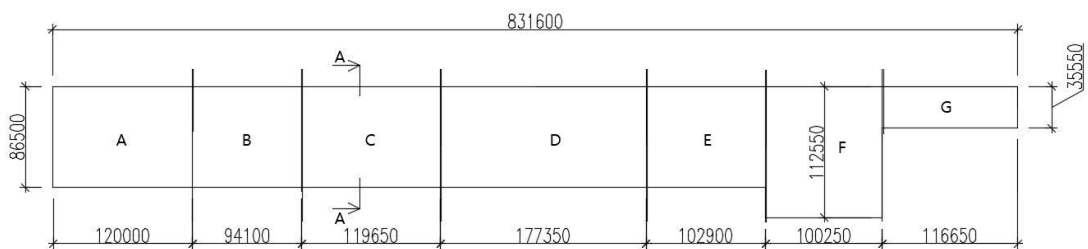

Figure 1.6-1 Building plan

$$b = 86,5 \text{ m}$$

$$d = 831,6 \text{ m}$$

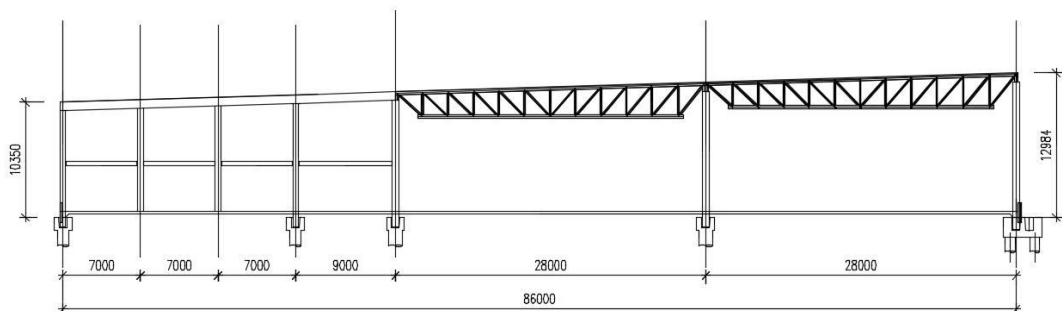

Figure 1.6-2 Cross-section A-A

$$H = 12,952 \text{ m}$$

$$h = 11,01 \text{ m}$$

$$A = 68\,505 \text{ m}^2$$

$$h_p = 0,66 \text{ m} \text{ — Height of parapet}$$

Pitch angle $\alpha = 3\% = 1,7^\circ$ — flat roof



To simplify and narrow down the work, this diploma thesis will deal with a single dilation section marked in the ground plan as “C” (see Figure 1.6-1 Building plan). For the purpose of this work, one truss from the main production hall will be designed in detail. Geometry of selected truss:

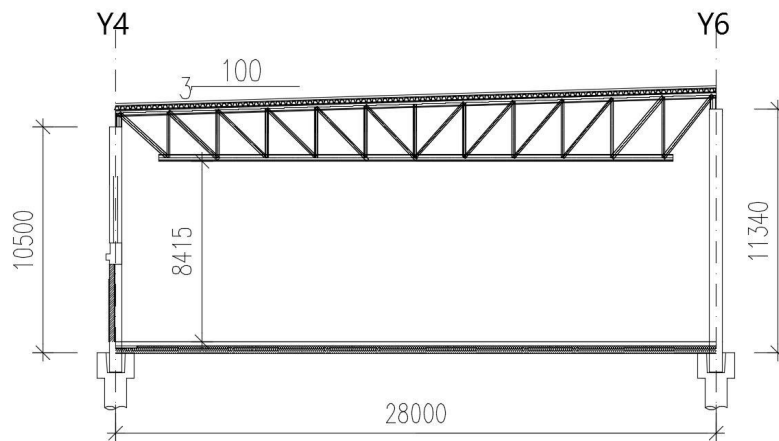

Figure 1.6-3 Geometry of the selected truss

$L = 28 \text{ m}$ — span of the selected truss

The steel structure is composed of the main grid frames located in the main module axes of the object. (The frames are interwoven with thin-walled purlins, girts and braces.) The anchoring of the columns to the foundation structures is by means of chemical anchors. The overall stability of the object in the lateral direction is ensured by the frame's own stiffness. In the longitudinal direction, the stability of the object is secured by transverse bracing.

4. Loads

Load analysis is carried out for characteristic (norm) load values of the structure. Design load values for limit state calculations are determined by relevant standards.

4.1. Permanent action

4.1.1. Self-weight

The actual weight of the load-bearing structures is generated by the calculation program. Partial coefficient $\gamma_g = 1,35$.



4.1.2. Other permanent loads

Constant loads are determined according to individual roofs, facade cladding and flooring. The weight of the individual layers is recalculated according to the respective data sheets or the volume of the respective materials.

		Characteristic values	Partial factor	Design values
		G_k	Y_g	G_d
		[kN/m ²]	[-]	[kN/m ²]
1.	THK1,5 PVC MEMBRANE SHEET	0,01	1,35	0,0135
2.	THK100 RIGID INSULATION	0,2	1,35	0,27
3.	THK40 MINERAL WOOL INSULATION	0,08	1,35	0,108
4.	SEPARATION SLIP SHEET	0,01	1,35	0,0135
5.	METAL ROOF DECK (aprox.)	0,1	1,35	0,135
6.	Technology	1	1,35	1,35
		1,4		1,89

Table 4.1-1 Summary of permanent loads

4.2. Variable actions

4.2.1. Imposed loads

Live load on the roof (access not provided except for maintenance) is 0,75 kN/m².

		Characteristic values	Partial factor	Design values
		G_k	Y_g	G_d
		[kN/m ²]	[-]	[kN/m ²]
1.	Live load on the roof	0,75	1,5	1,125

Table 4.2-1 Live load on the roof

There is also an administrative part in the production hall. Live load in office part is 2,5 kN/m².

		Characteristic values	Partial factor	Design values
		G_k	Y_g	G_d
		[kN/m ²]	[-]	[kN/m ²]
1.	Live load on the roof	2,5	1,5	3,75

Table 4.2-2 Live load in office part

4.2.2. Snow loads

The snow load is a variable load as the loading is not constant during the year. The snow load will vary depending on the location of the structure, the slope angle of the roof,



contribution and interference of other roofs and contribution and drifting at obstructions (e.g. roof parapet or another building wall).

The object is according to the classification ČSN EN 1991-1-3 "Structural load" in the first snow area. According to the Czech Hydrometeorological Institute, the standard snow load value is $S_k = 0,61 \text{ kN/m}^2$. These are mostly flat roofs with parapets. The load factor for the snow load is $\gamma_f = 1,5$ multiplied by the combination coefficient according to the combination used and the load.

Characteristic snow load zone: 1

Altitude of the building: 273m

Exposure coefficient $C_e=1,0$

Thermal coefficient $C_t=1,0$

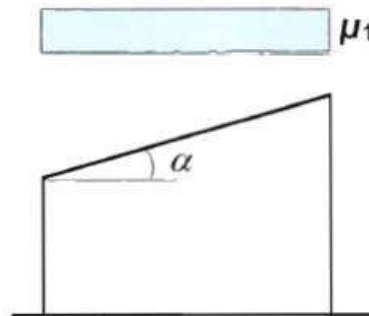

Figure 4.2-1 Snow load shape coefficient [2]

Snow load shape coefficient $\mu_1=0,8$

$$s_1 = \mu_1 \cdot C_e \cdot C_t \cdot c_k = 0,8 \cdot 1 \cdot 1 \cdot 0,61 = 0,488 \text{ kN/m}^2$$

Local effects – drifting at the edge of the roof:

$$\mu_2 = \gamma \cdot h / s_k$$

Where:

γ is the weight density of snow 2 kN/m^3

h is high of parapet

$$\mu_2 = 2 \cdot 0,66 / 0,61 = 2,16$$

$$0,8 \leq \mu_2 \leq 2$$

$$\mu_2 = 2$$

$$l_s = 2 \cdot h = 2 \cdot 0,66 = 1,32 \text{ m}$$



$$5 \leq l_s \leq 15$$

$$l_s = 5 \text{ m}$$

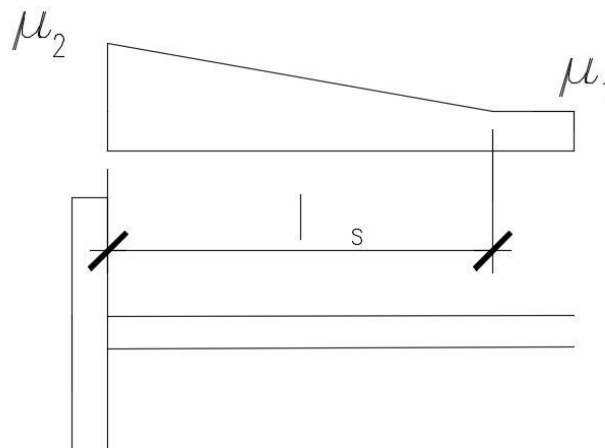

Figure 4.2-2 Snow load shape coefficients

$$s_2 = \mu_2 \cdot C_e \cdot C_t \cdot c_k = 2 \cdot 1 \cdot 1 \cdot 0,61 = 1,22 \text{ kN/m}^2$$

4.2.3. Wind load – external pressure

The object is located in II. wind area where the baseline wind speed v_b is taken into account, $v_{b0} = 25 \text{ m/s}$. Terrain category II. - area with low vegetation such as grass and isolated obstacles (trees, buildings). The resulting wind load depends on the size and location of the area under consideration (see static calculation). The load factor for wind load is $\gamma_f = 1.5$ multiplied by the combination coefficient according to the combination used and the load. It is considered according to ČSN EN 1991-1-4 "Wind load".

Season factor $c_{season}=1,0$

Directional factor $c_{dir}=1,0$

The basic wind velocity:

$$v_b = c_{dir} \cdot c_{season} \cdot v_{b,0} = 1 \cdot 1 \cdot 25 = 25 \text{ m/s}$$

$$z = 12,95 \text{ m}$$

$$z_0 = 0,05$$

$$z_{min} = 2$$

$$k_r = 0,19 \cdot \left(\frac{z_0}{z_{0,II}} \right)^{0,07} = 0,19 \cdot \left(\frac{0,05}{0,05} \right)^{0,07} = 0,19$$

$$c_r(z) = k_r \cdot \ln \left(\frac{z}{z_0} \right) = 0,19 \cdot \ln \left(\frac{12,95}{0,05} \right) = 1,056$$



$$c_0(z) = 1$$

$$v_m(z) = c_r(z) \cdot c_0(z) \cdot v_b = 1,056 \cdot 1 \cdot 25 = 26,4 \frac{m}{s}$$

$$I_v = \frac{k_1}{c_0(z) \cdot \ln\left(\frac{z}{z_0}\right)} = \frac{1}{1 \cdot \ln\left(\frac{12,95}{0,05}\right)} = 0,18$$

$$\rho = 1,25 \text{ kg/m}^3$$

The peak velocity pressure $q_p(z)$ at height z :

$$\begin{aligned} q_p(z) &= [1 + 7 \cdot I_v(z)] \cdot \frac{1}{2} \cdot \rho \cdot v_m^2(z) = [1 + 7 \cdot 0,18] \cdot \frac{1}{2} \cdot 1,25 \cdot 26,4^2 \\ &= 984 \text{ N/m}^2 = 0,984 \text{ kN/m}^2 \end{aligned}$$

$$d = 831 \text{ m}$$

$$b = 86,5 \text{ m}$$

$$e = \min(2 \cdot h; b) = \min(22,02; 86,5) = 22,02 \text{ m}$$

$$\frac{h}{d} = \frac{11,01}{831} = 0,013 \leq 0,25$$

$$\frac{h_p}{h} = \frac{0,66}{11,01} = 0,06$$

$$w_e = q_p(z) \cdot c_{pe}$$

External pressure coefficients and loads for building:

Vertical walls			Flat roof		
	C_{pe}	w_{pe}		C_{pe}	w_{pe}
A	-1,2	-1,181	F	-1,4	-1,378
B	-0,8	-0,787	G	-0,9	-0,886
C	-0,5	-0,492	H	-0,7	-0,689
D	0,7	0,689	I+	0,2	0,197
E	-0,3	-0,295	I-	-0,2	-0,197

Table 4.2-3 Wind coefficients and loads

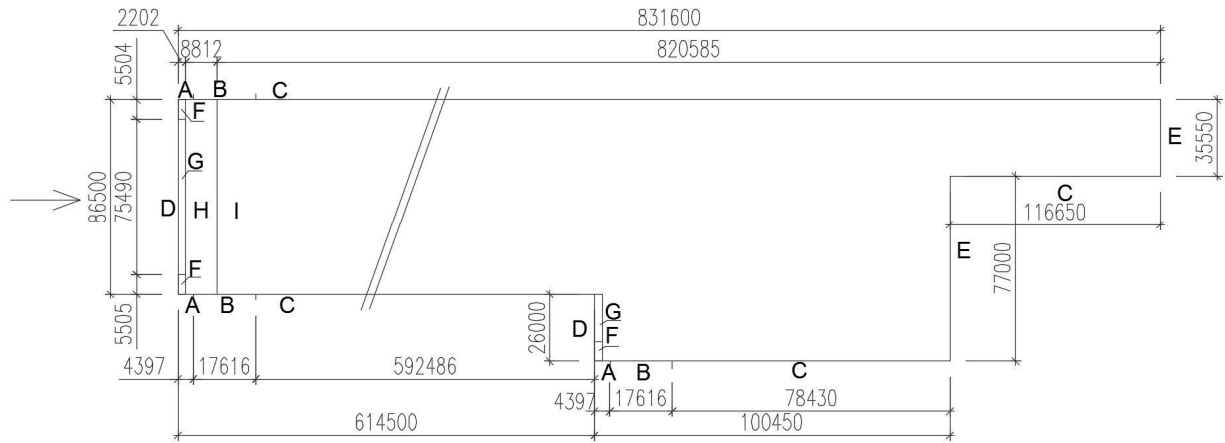

Figure 4.2-3 Longitudinal wind load zone

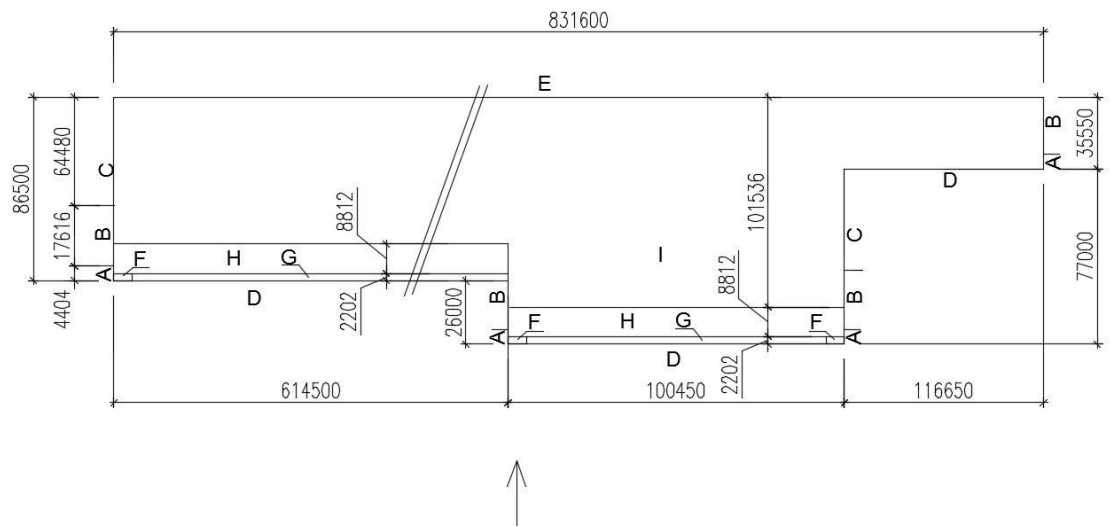

Figure 4.2-4 Transversal wind load zone

In the case of the longitudinal and transversal winds, the truss is located in I-area.

$$w_e(I+) = q_p(z) \cdot c_{pe} = 0,984 \cdot 0,2 = 0,197 \text{ kN/m}^2$$

$$w_e(I+) = 0,197 \cdot 5 = 0,985 \text{ kN/m'}$$

$$w_e(I-) = q_p(z) \cdot c_{pe} = 0,984 \cdot (-0,2) = -0,197 \text{ kN/m}^2$$

$$w_e(I-) = -0,197 \cdot 5 = -0,985 \text{ kN/m'}$$

4.2.4. Internal pressure

Internal and external pressures shall be considered to act at the same time. The internal pressure coefficient, c_{pi} , depends on the size and distribution of the openings in the building envelope.



	Area of envelope	Area of doors	Area of windows	Area of openings
	A [m ²]	a1 [m ²]	a2 [m ²]	a [m ²]
Nord side	15394,59	336	1020	1356
West side	3280,53	148,95	10	158,95
South side	15607,91	184	112	296
East side	3809,95	38,4	112	150,4

Table 4.2-4 Summary of openings areas

The Nord side is the dominant face.

$$a_N = 1356 \text{ m}^2 - \text{area of the openings at the dominant face}$$

$$a_{W+S+E} = 158,95 + 296 + 150,4 = 605,35 \text{ m}^2 - \text{area of the openings in the remaining faces}$$

$$\frac{a_N}{a_{W+S+E}} = \frac{1356}{605,35} = 2,24$$

Area of the openings at the dominant face is between 2 and 3 times the area of the remaining faces. Internal pressure coefficient will be derived using linear iteration.

$$c_{pi} = (0,75 + (0,9 - 0,75) \cdot 0,24) \cdot c_{pe} = 0,786 \cdot c_{pe}$$

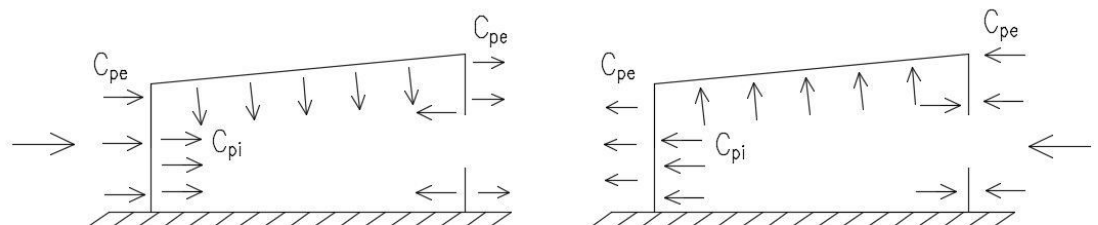

Figure 4.2-5 Pressure on surfaces

Internal pressure coefficients for building:

Transversal wind (South side) internal pressure (negative):

$$\begin{aligned} w_i &= q_p(z) \cdot c_{pi} = q_p(z) \cdot c_{pe,E} \cdot 0,9 = 0,984 \cdot (-0,3) \cdot 0,786 \\ &= -0,232 \text{ kN/m}^2 \end{aligned}$$

Transversal wind (West and East side) internal pressure:

$$w_i = q_p(z) \cdot c_{pi} = q_p(z) \cdot c_{pe,D} \cdot 0,9 = 0,984 \cdot 0,7 \cdot 0,786 = \mathbf{0,541 \text{ kN/m}^2}$$

In the case, when these openings are located in zones with different values of external pressures an area weighted average value of c_{pe} should be used.



Longitudinal wind (North side) internal pressure (negative):

$$c_{pe} = \frac{c_{peA} \cdot A_A + c_{peB} \cdot A_B + c_{peC} \cdot A_C}{A_{A+B+C}}$$
$$= \frac{-1,2 \cdot 7497 - 0,5 \cdot 17616 - 0,5 \cdot 809587}{831600} = -0,510$$

$$w_i = q_p(z) \cdot c_{pi} = 0,984 \cdot (-0,51) \cdot 0,786 = -\mathbf{0,394 \text{ kN/m}^2}$$

Negative internal pressure (sanction) will be used in combination with wind pressure on the roof.

4.2.5. Frictional force

$$b = 86,5 \text{ m}$$

$$d = 119 \text{ m}$$

$$h = 12,984 \text{ m}$$

$$z = \min(2b; 4h) = \min(173; 51,936) = 51,936 \text{ m}$$

The entire dilatation unit under consideration is located in the reference area.

$$A_{ref,roof} = 86,5 \cdot 119 = 10293,5 \text{ m}^2$$

$$c_{fr,roof} = 0,01 \text{ — frictional coefficients for roof (membrane with smooth surface)}$$

$$F_{fr,roof} = c_{fr,roof} \cdot q_p(z_e) = 0,01 \cdot 0,984 = 0,00984 \text{ kN/m}^2$$
$$\cong 0,010 \text{ kN/m}^2$$

$$c_{fr,walls} = 0,04 \text{ — frictional coefficients for walls (sandwich panels with folds)}$$

$$F_{fr,walls} = c_{fr,walls} \cdot q_p(z_e) = 0,04 \cdot 0,984 = 0,0394 \text{ kN/m}^2$$
$$\cong 0,040 \text{ kN/m}^2$$



4.2.6. Summarization of wind loads

Longitudinal wind:

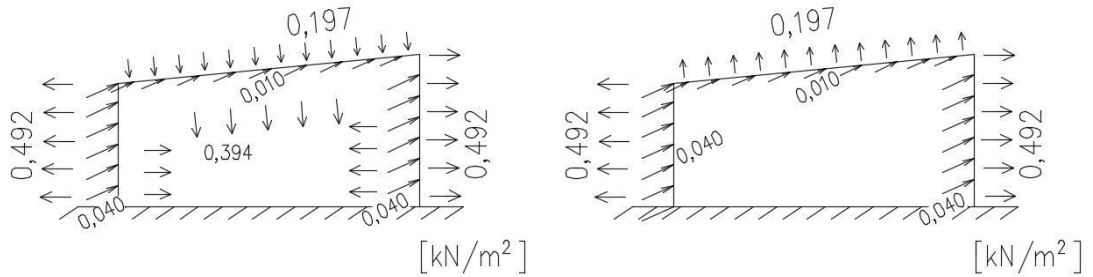

Figure 4.2-6 Principle sketch of longitudinal wind loads

Transversal wind X+:

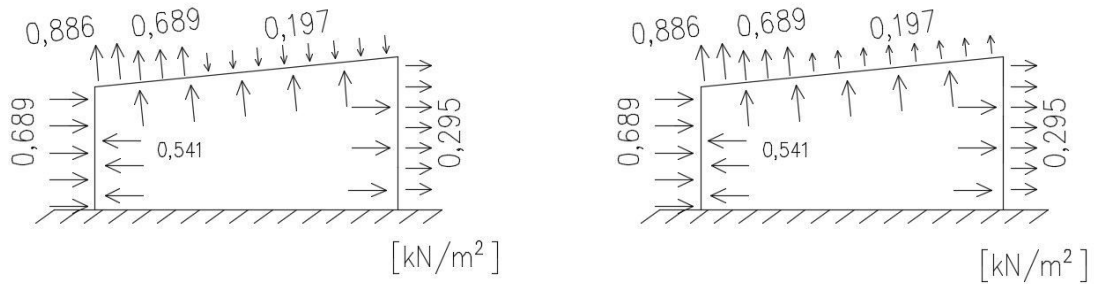

Figure 4.2-7 Principle sketch of transversal wind loads (X+)

Transversal wind X-:

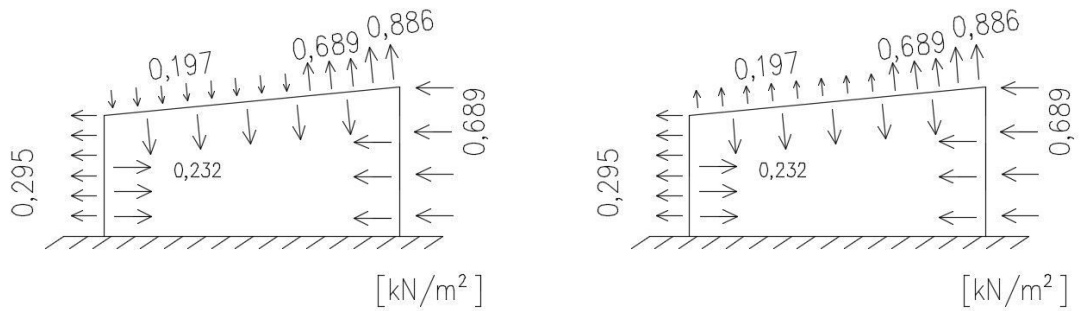
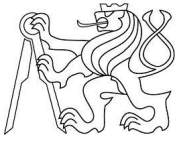

Figure 4.2-8 Principle sketch of transversal wind loads (X-)

In the following calculations, only critical loads will be considered, which is transverse wind suction and longitudinal wind pressure.



4.3. Load combinations

At ultimate limit state, in usual situations without accidental loads, the load combination can be determined by following expression:

$$\sum \gamma_G \cdot G_k + \gamma_Q \cdot Q_k + \sum \gamma_Q \cdot \psi_0 \cdot Q_k$$

ULS:

LC1 — 1. max pressure:

$$1,35 \cdot \textit{permanent loads} + 1,5 \cdot \textit{snow} + 1,5 \cdot 0,6 \cdot \textit{wind}(+)$$

LC2 — 2. max pressure:

$$1,35 \cdot \textit{permanent loads} + 1,5 \cdot \textit{wind}(+) + 1,5 \cdot 0,7 \cdot \textit{snow}$$

LC3 — 3. max pressure – Live load on area of up to 10m² (only for trapezoidal sheets and purlins design)

$$1,35 \cdot \textit{permanent loads} + 1,5 \cdot \textit{live load}$$

LC4 — 1. max suction:

$$1,0 \cdot \textit{self weight} + 1,5 \cdot \textit{wind}(-)$$

SLS:

LC5 —1. deflection:

$$1,0 \cdot \textit{permanent loads} + 1,0 \cdot \textit{snow} + 0,6 \cdot \textit{wind}(+)$$

LC6 —2. deflection:

$$1,0 \cdot \textit{permanent loads} + 1,0 \cdot \textit{wind}(+) + 0,7 \cdot \textit{snow}$$

In all load cases column imperfection (9.2) and imperfections of the bracing system (9.3) will be included.

5. Internal forces

The internal forces were calculated using the Dlubal RFEM software. In this chapter will be summarization of the internal forces in the members to be used in the following chapters.



5.1. Columns

		N _{Ed} [kN]	V _{ed,z} [kN]	M _{ed,y} [kNm]
1) Inner column in hall part	CO 2	-767,756	-0,060	0
	CO 3	70,132	0	0
2) Outer column in hall part	CO2	-468,238	7,273	23,81
	CO3	28,753	-56,156	180,71
	CO8	-285,000	-66,930	-217,7
3) Inner column in administrative part	CO8	-793,015	0	0
	CO3	62,373	0	0
4) Outer column in administrative part	CO2	-571,494	-3,11	2,644

Table 5.1-1 Internal forces in the columns

5.2. Truss

RFEM5
CO2: ULS max pressure 2

Internal forces - N		
	x [m]	N [kN]
max	13.000	1239.082
min	26.000	-0.001

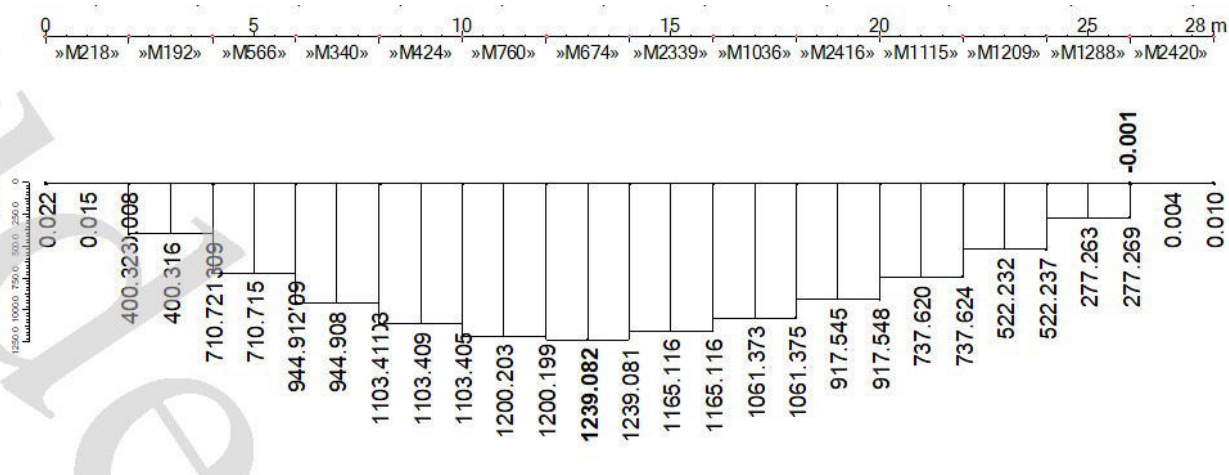

Figure 5.2-1 Internal force in lower truss (CO2)

	Forces		
	Member No.	N _{ed} [kN]	length L [m]
S1	100	-319,35	1,642
D1	205	-46,75	2,551
S2	221	-258,93	1,703
D3	245	-23,48	2,627
S3	284	-203,93	1,764
D4	319	-18,70	2,667
D2	373	-33,95	2,588
D5	402	-10,06	2,707
S5	494	-93,33	1,885
S4	539	-144,99	1,824



D6	599	-6,80	2,748
S6	654	-41,77	1,945
D8	772	-7,82	2,876
S7	823	-56,98	2,006
S8	830	-114,72	2,067
S10	1064	-206,85	2,188
D7	1099	-15,49	2,790
D11	1108	-22,06	3,009
D10	1170	-15,22	2,964
S13	1316	-338,58	2,369
S11	1345	-252,39	2,248
D13	1370	-33,59	3,101
D14	1481	-40,92	3,147
S9	1604	-161,92	2,127
D9	1606	-15,14	2,920
S12	1877	-293,90	2,309
D12	2227	-27,11	3,055
Upper chord	594	-1319,67	28,006
Lower chord	674	-106,88	28,00

Table 5.2-1 Internal forces in truss (envelope)

6. Roof

In the following chapters, it deals with the comparison of roof systems of steel hall with or without purlin. Static tables (according to EN 1990- and EN 1993-1-3) will be used for trapezoidal sheet design. The roof casing is stiff in its plane.

For the design of the trapezoidal sheet, three load combinations will be considered: for maximum possible pressure, maximum wind suction and life load on the roof (maintenance only).

1. LC - 1. max pressure		kN/m ²	kN/m ²	
1	Permanent	1,4	1,35	1,890
2	Snow	0,488	1,5	0,732
3	Wind (I) * $\psi=0,6$	0,118	1,5	0,177
4	Internal pressure(-0,394) * $\psi=0,6$	0,236	1,5	0,355
		2,242	3,154	

2. LC - 2. max pressure		kN/m ²	kN/m ²	
1	Permanent	1,4	1,35	1,890



2	Snow * $\psi=0,5$	0,244	1,5	0,366
3	Wind (I)	0,197	1,5	0,295
4	Internal pressure (-0,394)	0,394	1,5	0,591
		2,235		3,142

3. LC - Live load kN/m² kN/m²

1	Permanent	1,4	1,35	1,89
2	Live load on the roof	0,75	1,5	1,125
		2,15		3,015

4. LC - suction kN/m² kN/m²

1	Permanent	0,4	1	0,4
2	External wind (H)	-0,689	1,5	-1,033
3	Internal suction (0,541)	-0,541	1,5	-0,812
		-0,830		-1,445

Table 5.2-1 loads on roof

6.1. Roof system without purlin

The roof structure consists of a bearing trapezoidal sheet, thermal insulation (polystyrene mineral wool) and waterproofing.

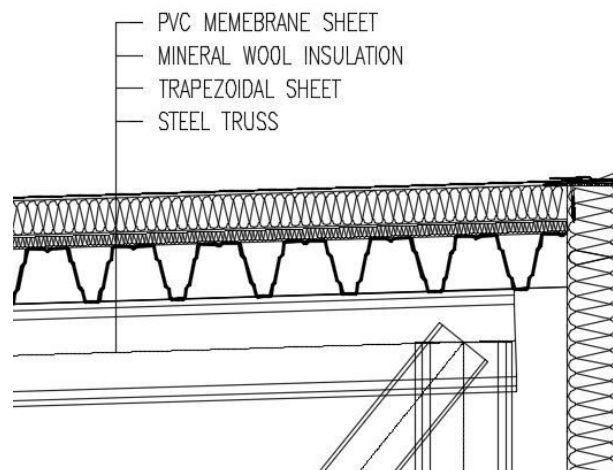

Figure 6.1-1 Scheme of roof system without purlin

6.1.1. Design of trapezoidal sheets. Distance between trusses is 5m

The individual pieces of trapezoidal sheets will be connected with bolts on the site. That's why it's considered as continuous beam along the entire length of the building.

For the design are used static tables from the trapezoidal sheet supplier. TR 135/310/0,75 S320GD in positive position, cross section characteristics:



$$f_{Rd} = 3,23 \text{ kN/m}^2 \text{ — according to static tables}$$

$$m = 10,7 \text{ kg/m}^2$$

$$f_y = 320 \text{ MPa}$$

$$f_{Ed} = 3,154 \text{ kN/m}^2 \leq 3,23 \text{ kN/m}^2 = f_{Rd}$$

6.1.2. Deflection

Deflection and load capacity above support check is determined from the characteristic values of constant and variable loads.

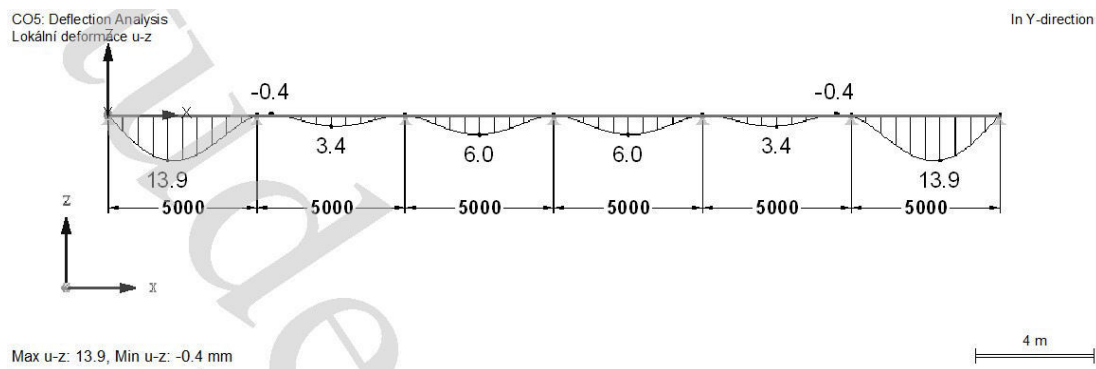

Figure 6.1-2 Deflection

$$\delta = 13,9 \text{ mm}$$

$$\delta_{lim} = \frac{L}{200} = \frac{5000}{200} = 25 \text{ mm}$$

$$\delta < \delta_{lim}$$

OK

6.1.3. Load capacity above support

$$F_{Ed} \leq n \cdot R_{w,Rd}$$

Where:

$R_{w,Rd}$ — load capacity of the one web

n — number of webs per 1 m plate.

$$n = 7$$

$$R_{w,Rd} = \alpha \cdot t^2 \cdot \sqrt{f_{yb} \cdot E} \cdot (1 - 0,1 \cdot \sqrt{r/t}) \cdot (0,5 + \sqrt{0,2 \cdot l_a/t}) \cdot \frac{2,4 + (\phi/90)^2}{\gamma_{M1}}$$



Where:

$$\alpha = 0,15 \text{ — coefficient for sheeting profile category 2 [3]}$$

$$t = 0,75 \text{ mm — profile thickness}$$

$$r = 6 \text{ mm — internal radius of the corners}$$

$$h_w = 135 \text{ mm — profile height}$$

$$\phi = 69,42^\circ$$

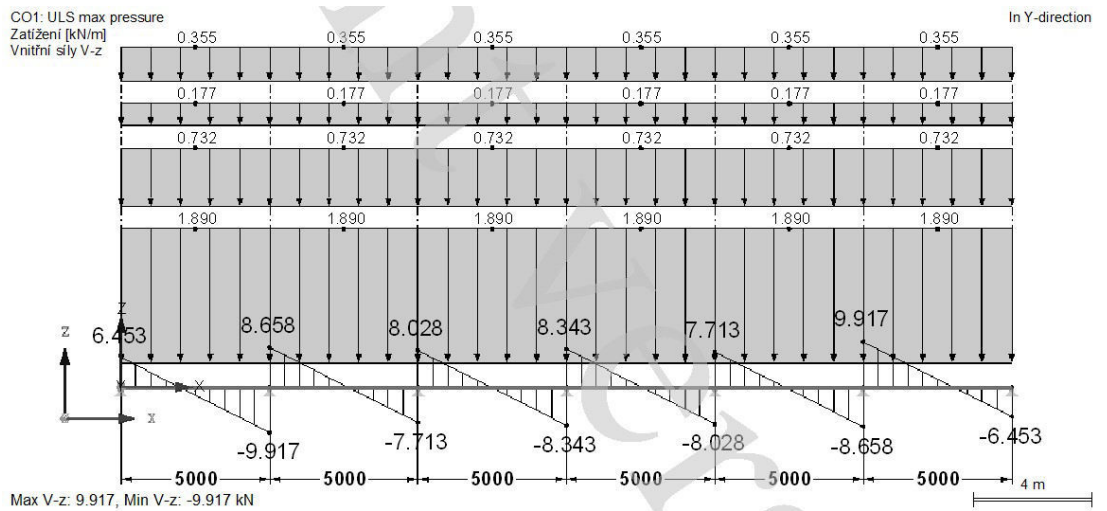

Figure 6.1-3 Shear forces and reaction

$$V_{Ed,1} = -9,917 \text{ kN}$$

$$V_{Ed,2} = 8,658 \text{ kN}$$

$$F_{Ed} = R_{Ed} = |V_{Ed,1}| + |V_{Ed,2}| = 18,511 \text{ kN}$$

$$\beta = \frac{|V_{Ed,1}| - |V_{Ed,2}|}{|V_{Ed,1}| + |V_{Ed,2}|} = \frac{9,917 - 8,658}{9,917 + 8,658} = 0,068$$

$$\beta < 0,2 \rightarrow l_a = s_s = 200 \text{ mm — expected width of support}$$



$$\begin{aligned}
 R_{w,Rd} &= \alpha \cdot t^2 \cdot \sqrt{f_{yb} \cdot E} \cdot (1 - 0,1 \cdot \sqrt{r/t}) \cdot \left(0,5 + \sqrt{0,2 \cdot \frac{l_a}{t}}\right) \\
 &\quad \cdot \left(2,4 + \left(\frac{\phi}{90}\right)^2\right) / \gamma_{M1} \\
 &= 0,15 \cdot 0,75^2 \cdot \sqrt{320 \cdot 210000} \cdot (1 - 0,1 \cdot \sqrt{6/0,75}) \\
 &\quad \cdot \left(0,5 + \sqrt{0,2 \cdot \frac{200}{0,75}}\right) \cdot \left(2,4 + \left(\frac{69,42}{90}\right)^2\right) / 1 = 11,592 \text{ kN}
 \end{aligned}$$

$$F_{Ed} = 18,511 \text{ kN} \leq n \cdot R_{w,Rd} = 7 \cdot 11,592 = 81,144 \text{ kN}$$

OK

6.1.4. Bending moment

To assess the bending moment, characteristics of the effective cross-section of the trapezoidal sheet TR 135/310/0,75 will be used:

$$W_{y,eff+} = 42,36 \cdot 10^3 \text{ mm}^3$$

$$W_{y,eff-} = 35,59 \cdot 10^3 \text{ mm}^3$$

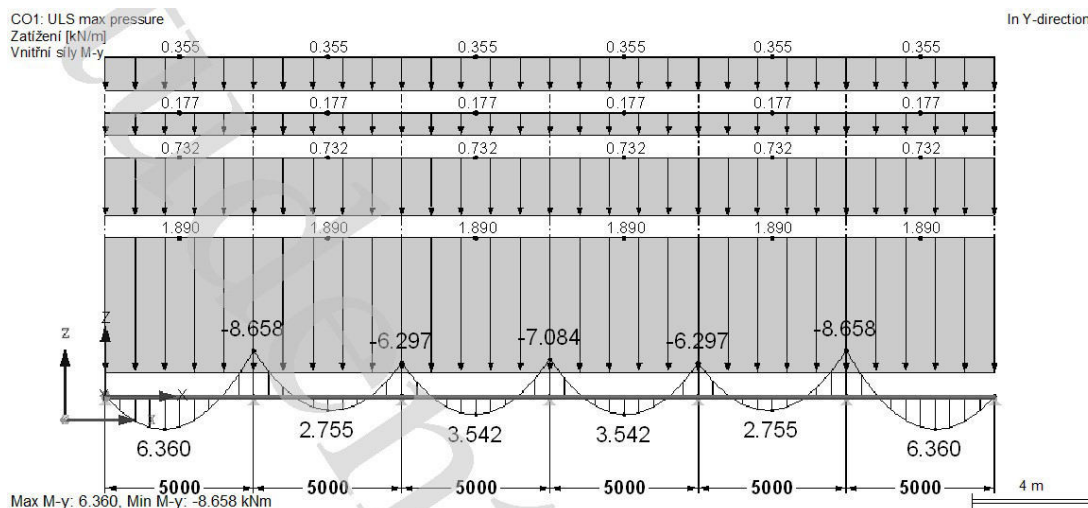

Figure 6.1-4 Bending moments

$$M_{Ed+} = 6,360 \text{ kNm}$$

$$M_{Ed-} = -8,658 \text{ kNm}$$

$$M_{Rd+} = W_{y,eff,+} \cdot f_y = 42,36 \cdot 10^3 \cdot 320 = 13,55 \text{ kNm} > M_{Ed+}$$



OK

$$M_{Rd-} = W_{y,eff,-} \cdot f_y = 35,59 \cdot 10^3 \cdot 320 = 11,389 \text{ kNm} > M_{Ed-}$$

OK

Combination of bending moment and shear forces:

$$\frac{F_{Ed}}{R_{w,Rd} \cdot n} + \frac{M_{Ed}}{M_{Rd}} \leq 1,25$$

$$\frac{18,511}{81,144} + \frac{8,658}{11,389} = 1,033 \leq 1,24$$

OK

Trapezoidal sheet TR 135/310/0,75 satisfied check

6.1.5. Design of trapezoidal sheets. Distance between trusses is 7m

For the design are used static tables from the trapezoidal sheet supplier.

TR 160/250/1,0 S320GD in positive position, cross section characteristics:

$$f_{Rd} = 3,37 \text{ kN/m}^2 \text{ — according to static tables}$$

$$m = 14,1 \text{ kg/m}^2$$

$$f_y = 320 \text{ MPa}$$

$$f_{Ed} = 3,154 \text{ kN/m}^2 \leq 3,37 \text{ kN/m}^2 = f_{Rd}$$

OK

Deflection is determined from the characteristic values of constant and variable loads.

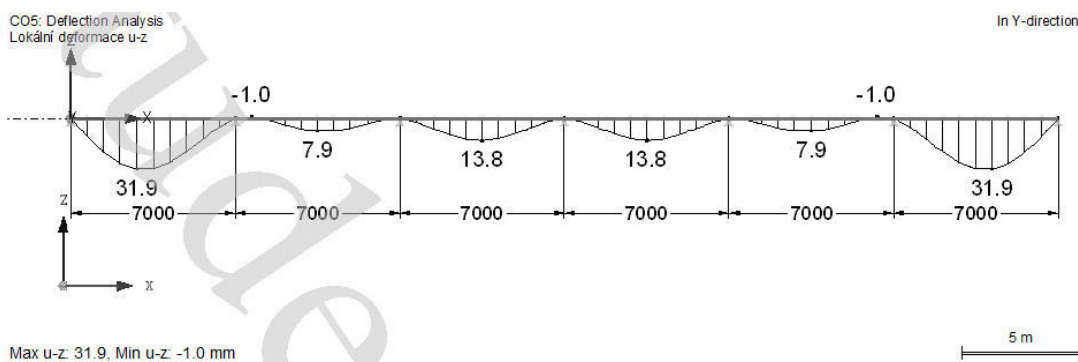

Figure 6.1-5 Deflection

$$\delta = 31,9 \text{ mm}$$



$$\delta_{lim} = \frac{L}{200} = \frac{7000}{200} = 35 \text{ mm}$$

$$\delta < \delta_{lim}$$

OK

6.1.5.1. Load capacity above support

$$F_{Ed} \leq n \cdot R_{w,Rd}$$

Where:

$R_{w,Rd}$ — load capacity of the one web

n — number of webs per 1 m plate.

$$n = 6$$

$$R_{w,Rd} = \alpha \cdot t^2 \cdot \sqrt{f_{yb} \cdot E} \cdot (1 - 0,1 \cdot \sqrt{r/t}) \cdot (0,5 + \sqrt{0,2 \cdot l_a/t}) \cdot \frac{2,4 + (\phi/90)^2}{\gamma_{M1}}$$

Where:

$\alpha = 0,15$ — coefficient for sheeting profile category 2 [3]

$t = 0,88 \text{ mm}$ — profile thickness

$r = 6 \text{ mm}$ — internal radius of the corners

$h_w = 160 \text{ mm}$ — profile height

$\phi = 69,42^\circ$

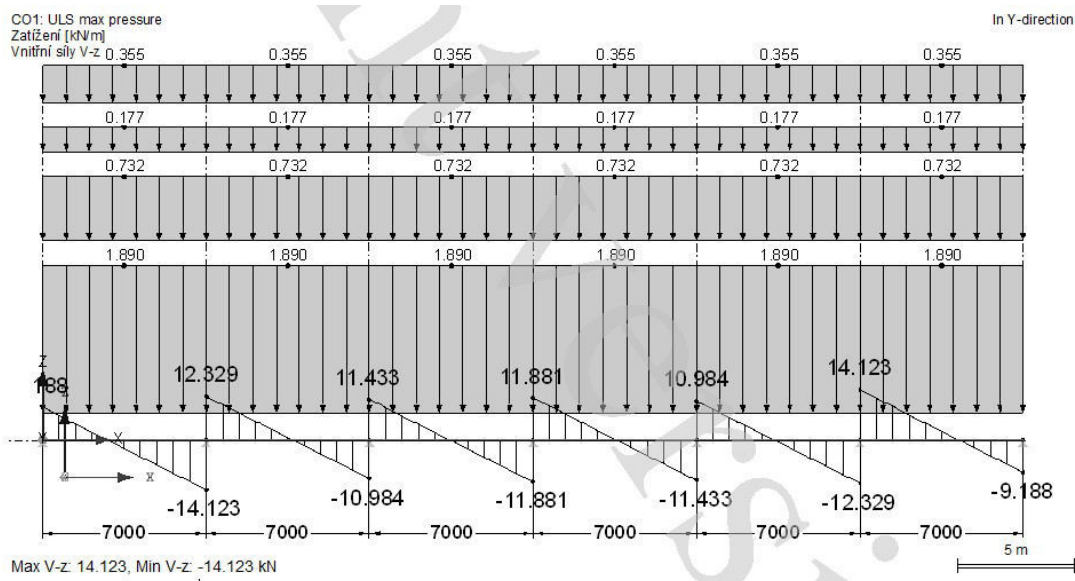



Figure 6.1-6 Shear forces and reaction

$$V_{Ed,1} = -14,123 \text{ kN}$$

$$V_{Ed,2} = 12,329 \text{ kN}$$

$$F_{Ed} = R_{Ed} = |V_{Ed,1}| + |V_{Ed,2}| = 26,583 \text{ kN}$$

$$\beta = \frac{|V_{Ed,1}| - |V_{Ed,2}|}{|V_{Ed,1}| + |V_{Ed,2}|} = \frac{13,378 - 11,680}{13,378 + 11,680} = 0,068$$

$$\beta < 0,2 \rightarrow l_a = s_s = 200 \text{ mm} - \text{expected width of support}$$

$$\begin{aligned} R_{w,Rd} &= \alpha \cdot t^2 \cdot \sqrt{f_{yb} \cdot E} \cdot \left(1 - 0,1 \cdot \sqrt{r/t}\right) \cdot \left(0,5 + \sqrt{0,2 \cdot \frac{l_a}{t}}\right) \\ &\quad \cdot \left(2,4 + \left(\frac{\phi}{90}\right)^2\right) / \gamma_{M1} \\ &= 0,15 \cdot 0,88^2 \cdot \sqrt{320 \cdot 210000} \cdot \left(1 - 0,1 \cdot \sqrt{6/0,88}\right) \\ &\quad \cdot \left(0,5 + \sqrt{0,2 \cdot \frac{200}{0,88}}\right) \cdot \left(2,4 + \left(\frac{69,42}{90}\right)^2\right) / 1 = 15,260 \text{ kN} \end{aligned}$$

$$F_{Ed} = 26,583 \text{ kN} \leq n \cdot R_{w,Rd} = 6 \cdot 15,260 = 91,562 \text{ kN}$$

OK

6.1.6. Bending moment

To assess the bending moment, characteristics of the effective cross-section of the trapezoidal sheet TR 160/250/0,88 will be used:

$$W_{y,eff+} = 65,09 \cdot 10^3 \text{ mm}^3$$

$$W_{y,eff-} = 63,88 \cdot 10^3 \text{ mm}^3$$

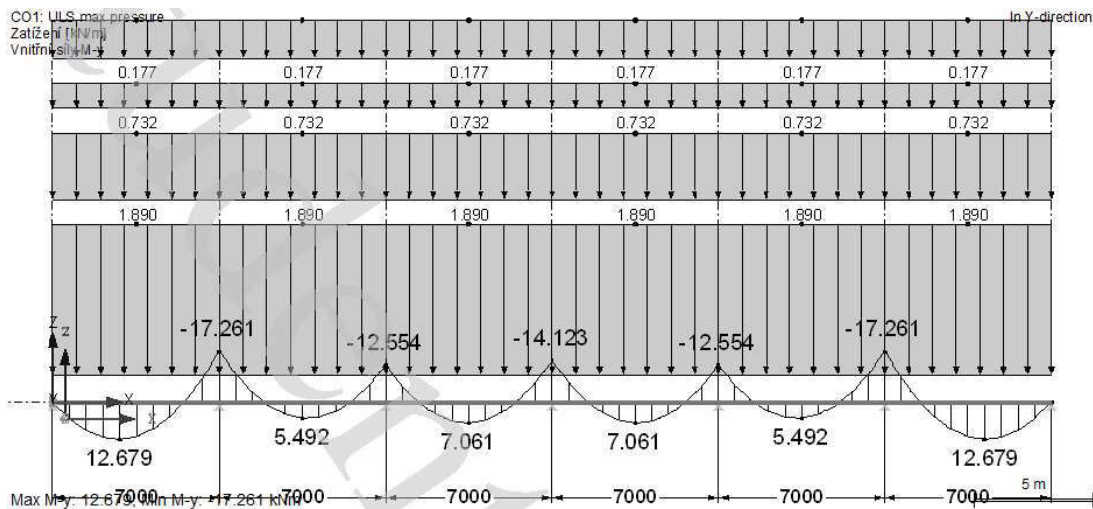

Figure 6.1-7 Bending moments

$$M_{Ed+} = 12,679 \text{ kNm}$$

$$M_{Ed-} = -17,261 \text{ kNm}$$

$$M_{Rd+} = W_{y,eff,+} \cdot f_y = 65,09 \cdot 10^3 \cdot 320 = 20,829 \text{ kNm} > M_{Ed+}$$

OK

$$M_{Rd-} = W_{y,eff,-} \cdot f_y = 63,88 \cdot 10^3 \cdot 320 = 20,441 \text{ kNm} > M_{Ed-}$$

OK

Combination of bending moment and shear forces:

$$\frac{F_{Ed}}{R_{w,Rd} \cdot n} + \frac{M_{Ed}}{M_{Rd}} \leq 1,25$$

$$\frac{25,258}{91,562} + \frac{17,261}{20,441} = 1,082 \leq 1,25$$

OK

Trapezoidal sheet TR 160/250/1,0 satisfied check

6.2. Roof system with purlin

The roof construction are carried by the purlins on the trusses. This solution increases the thickness of the roof, but it probably will be lightweight and more sophisticated. A folded roof is designed using thin-wall cold-formed profiles.

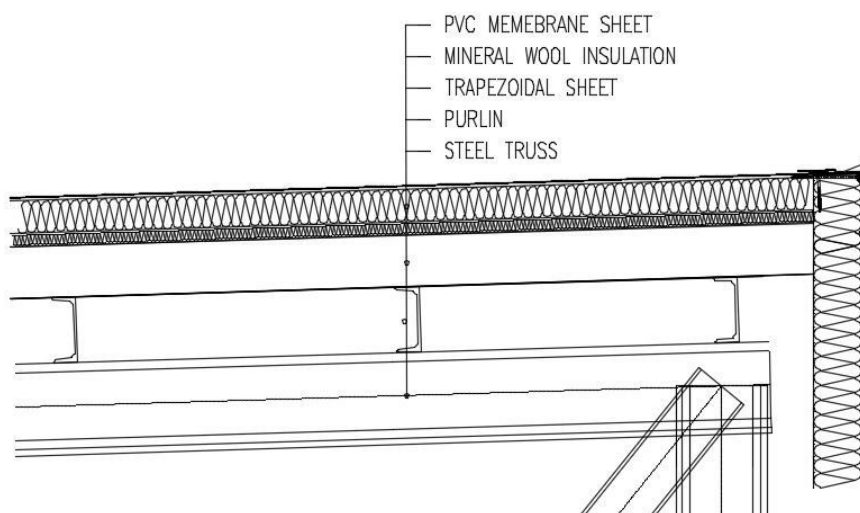

Figure 6.2-1 Scheme of roof system with purlin

6.2.1. Design of trapezoidal sheet

In this case a lighter trapezoidal sheet (e.g. CB 55/250/0,75 320GD) is used.

TR 35/207/0,75 320GD in positive position, cross section characteristics:

$f_{Rd} = 4,35 \text{ kN/m}^2$ — according to static tables for 1,5m distance between support

$m = 7,2 \text{ kg/m}^2$

$f_y = 320 \text{ MPa}$

$f_{Ed} = 3,154 \text{ kN/m}^2 \leq 4,35 \text{ kN/m}^2 = f_{Rd}$

OK

Deflection is determined from the characteristic values of constant and variable loads.

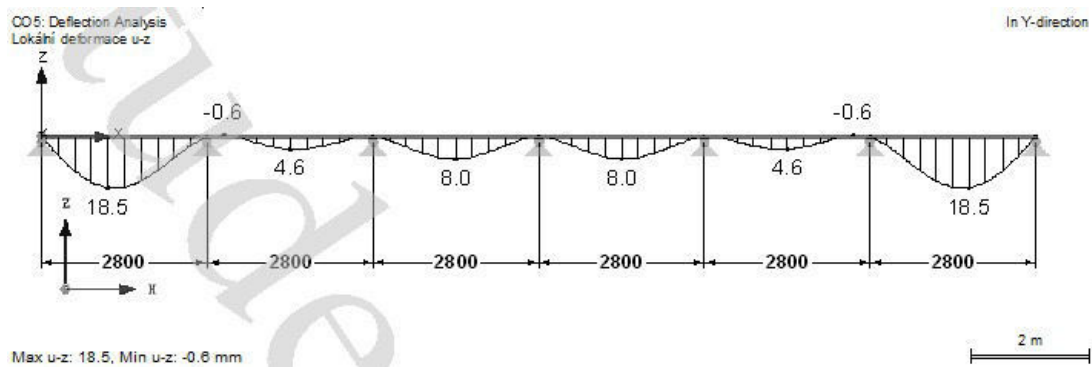

Figure 6.2-2 Deflection



$$\delta = 8 \text{ mm}$$

The thicker sheet will be used for the sider field.

$$\delta_{lim} = \frac{L}{200} = \frac{2800}{200} = 14 \text{ mm}$$

$$\delta < \delta_{lim}$$

OK

Trapezoidal sheet CB 35/207/0,75 satisfied check

6.2.2. Design of purlin

The purlin will be designed as a thin-walled Z-cross section (S350GD) continuous beam. The assumed distance between purlins is 2 m.

1. LC - max pressure		kN/m ²	kN/m'	kN/m'	
1	Permanent	1,4	2,800	1,35	3,780
2	Trapezoidal sheet	0,063	0,126	1,35	0,170
3	Snow	0,488	0,976	1,5	1,464
4	Wind * $\psi=0,6$	0,118	0,236	1,5	0,354
5	Internal pressure(0,394) * $\psi=0,6$	0,236	0,473	1,5	0,709
		2,305	4,611	6,478	

2. LC - max pressure		kN/m ²	kN/m'	kN/m'	
1	Permanent	1,4	2,800	1,35	3,780
2	Trapezoidal sheet	0,063	0,126	1,35	0,170
3	Snow * $\psi=0,5$	0,244	0,488	1,5	0,732
4	Wind	0,197	0,394	1,5	0,590
5	Internal pressure (0,394)	0,394	0,788	1,5	1,182
		2,298	4,596	6,455	

3. LC - Live load		kN/m ²	kN/m'	kN/m'	
1	Permanent	1,4	2,800	1,35	3,780
2	Trapezoidal sheet	0,063	0,126	1,35	0,1701
3	Live load	0,75	1,500	1,5	2,250
		2,15	4,426	6,200	

4. LC - suction		kN/m ²	kN/m'	kN/m'	
1	Permanent	0,4	0,800	1	0,800
2	Trapezoidal sheet	0,063	0,126	1	0,126
3	Wind	-0,197	-0,394	1,5	-0,590
4	Internal pressure (0,541)	-0,541	-1,082	1,5	-1,623
		-0,275	-0,550	-1,287	

Table 6.2-1 Loads on purlin at the center of the roof



1. LC - max pressure		kN/m ²	kN/m'	kN/m'	
1	Permanent	1,4	1,960	1,35	3,780
2	Trapezoidal sheet	0,063	0,088	1,35	0,170
3	Snow	0,732	1,464	1,5	2,196
4	Wind (I) * $\psi=0,6$	0,118	0,165	1,5	0,354
5	Internal pressure (0,394) * $\psi=0,6$	0,236	0,331	1,5	0,496
		2,313	4,957		6,997

Table 6.2-2 Loads on purlin at the edge of the roof

According to static tables from the manufacturer, the profile Z 200/2,0 F for the internal fields of the roof and Z 200/2,5 F for the edge field of the roof is designed for 5m distance between purlins.

$$m = 6,50 \text{ kg/m}$$

$$H = 200 \text{ mm}$$

$$b = 76 \text{ mm}$$

$$f_{Ed} = 6,478 \text{ kN/m'}$$

$$f_{Rd} = 6,690 \text{ kN/m' — according static table for 5 m span}$$

$$f_{Ed} = 6,478 \text{ kN/m' } \leq f_{Ed} = 6,690 \text{ kN/m'}$$

Profile Z 350/2,5 (internal span of the roof) and Z 350/2,5 (for the edge span of the roof) is designed for 7m distance between purlins.

Z 300/2,5 cross-section characteristics:

$$m = 12,10 \text{ kg/m}$$

$$H = 350 \text{ mm}$$

$$b = 103 \text{ mm}$$

$$f_{Ed} = 6,478 \text{ kN/m'}$$

$$f_{Rd} = 6,90 \text{ kN/m' — according static table}$$

$$f_{Ed} = 6,478 \text{ kN/m' } \leq f_{Ed} = 6,90 \text{ kN/m'}$$

OK



6.3. Summarization

	Without purlin	With purlin
5m	9,7	10,45
7m	14,1	13,25

Table 6.3-1 Weight of the roof structure (kg/m²)

As seen from the Table 6.3-1, clearly, more economical solution, for the distance 5m between trusses, is the roof system without purlins. In the case of 7 m span between trusses, the roof system with purlin has a lower weight. It may seem like that system comes out better (lighter = more economical), but it also have to consider the price for transport and assembly. The profile of the purlin, which complies for the 7m span (Z350 / 2.5) is not a regular profile in the Czech Republic. There may be extra costs for an atypical profile. In the end, this solution can be expensive.

Based on the previous consideration, roof system without purlins was chosen (7m distance between trusses).

7. Cladding wall

The wall cladding is made of sandwich panels, which are supplied as a compact building component. Sandwich panels RUUKKI SPB150WS will be designed using RUUKKI's TryPan software (see Appendix).

Panels formed by two metal sheets linked by a layer of insulating material, which can be manufactured with polyurethane foam or with mineral wool. Horizontal (longitudinal) sheet direction will be considered.

8. Preliminary truss design

8.1. Material choice

In the European market there is a large variety of construction steel. In this thesis, S690 quenched and tempered steel grade is chosen to be the upper limit of HSS grades to be used. Hybrid truss designs are performed using high strength steel S690 in combination with mild steel grade S355.



	t ≤ 40 mm		40 < t ≤ 80 mm		
Grade	fy [Mpa]	fu [Mpa]	fy [Mpa]	fu [Mpa]	$\epsilon = \sqrt{235/f_y}$
S355	355	510	335	470	0,81
S420	460	540	430	540	0,71
	t ≤ 50 mm		50 < t ≤ 100 mm		
S690	690	770	650	760	0,58

Table 8.1-1 Yield and ultimate strengths of steel grades under consideration

8.2. Conceptual choice

Generally, when selecting the “correct” truss type, it is important to find a structure that will perform its required function and present an acceptable appearance at minimum costs. In that respect different types have to be examined before the final decision. In this chapter will be compared the different height of the truss and evaluated the most appropriate static scheme of the frame.

Truss is a structure that "consists of two-force members only, where the members are organized so that the assemblage as a whole behaves as a single object". [Plesha, Michael E.; Gray, Gary L.; Costanzo, Francesco (2013). Engineering Mechanics: Statics]

Generally, hollow section are used for elements stressed by the primary axial forces. There are a few advantages of hollow sections over open sections:

- These sections offer structural advantages in case of members subject to compression and/or in torsion;
- high efficiency for lateral stability due to significant large torsional stiffness;
- Rectangular hollow sections (RHS) offer an easy connections to the flat face;
- Larger assortment of cross-section of high-strength steel. Open sections are not standardized in wide variety of profiles for high strength steel. They are usually made out of plates, afterwards there are bended and welded;
- Esthetical pleasing shape.

RHS (rectangular hollow section) members is a practical alternative for CHS (circular hollow section) members:

- CHS require specialized profiling for connections;
- RHS members are more economic to fabricate. CHS require special automated equipment, which is much more expensive;



- Deck can be laid directly on the chord member

From these facts, RHS are chosen for the truss members.

8.2.1. Height choice (Geometry of the considered variants)

$L = 28\text{ m}$ — span of the truss

$b = 7\text{ m}$ — distance between trusses

Four variants of the height of the girder will be considered.

Option 1:

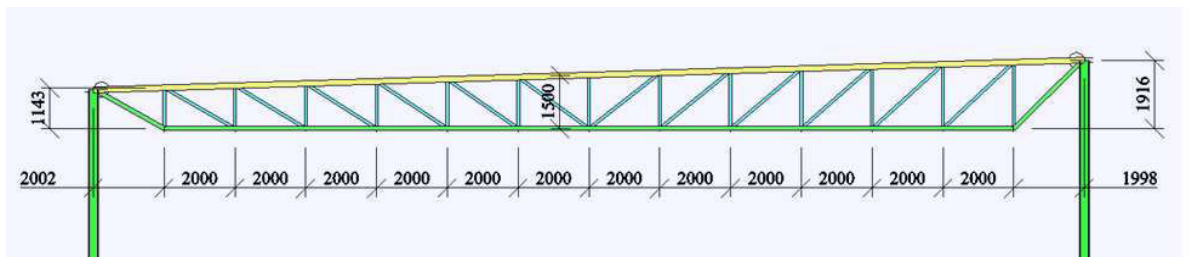

Figure 8.2-1 Geometry of the truss 1

Option 2:

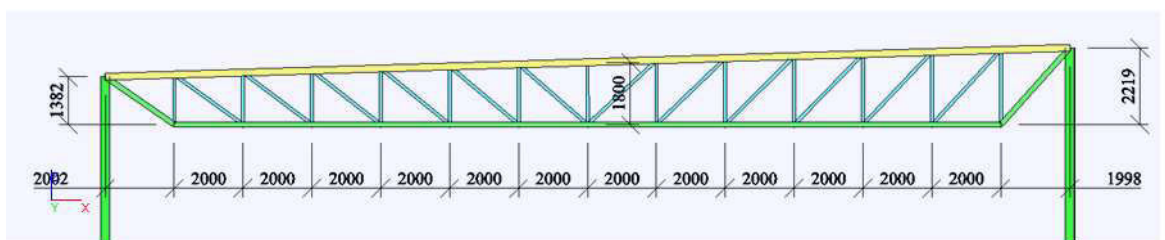

Figure 8.2-2 Geometry of the truss

Option 3:

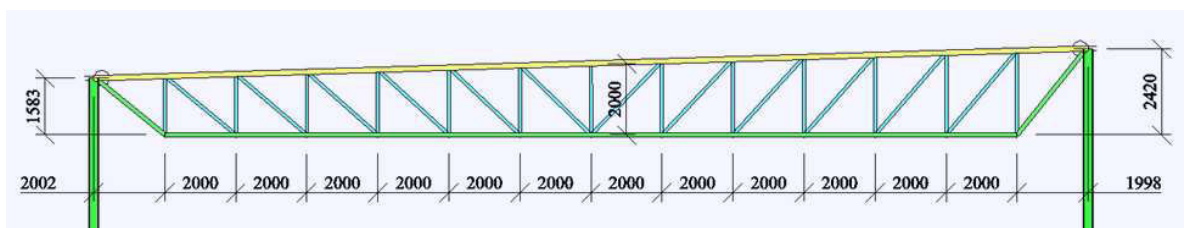

Figure 8.2-3 Geometry of the truss 3



Option 4:

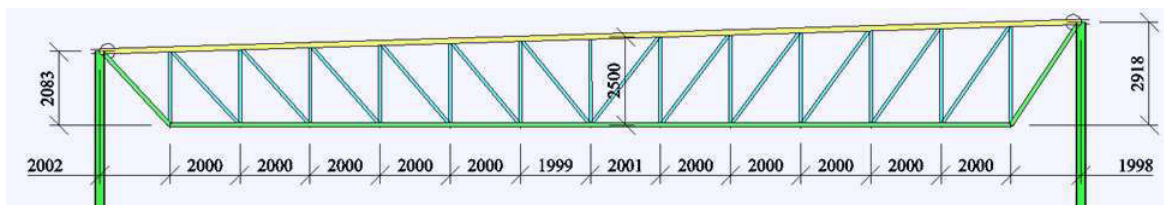

Figure 8.2-4 Geometry of the truss 4

Option 5:

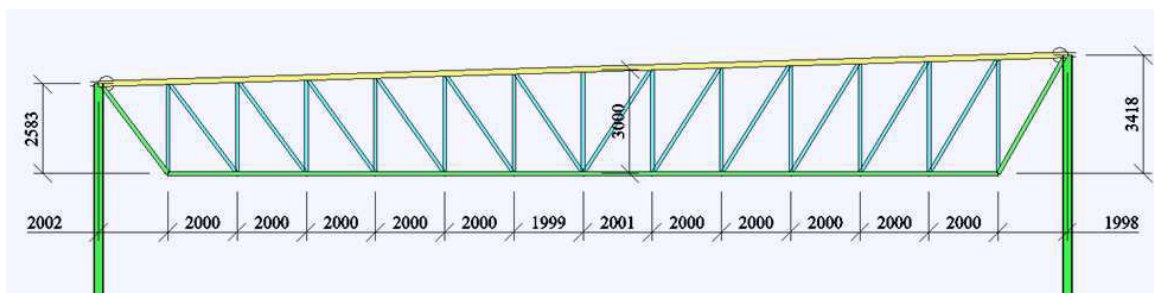

Figure 8.2-5 Geometry of the truss 5

8.3. Loads combinations

The permanent load on the trusses includes the weight of trapezoidal sheet and technology, except for the loading combination LC4, where only the weight of the structure (without technology) is considered. The distance between trusses is 7m.

1. LC - 1. max pressure		kN/m ²	kN/m'	kN/m'	
1	Permanent	1,541	10,787	1,35	14,562
2	Snow	0,488	3,416	1,5	5,124
3	Wind (I) = 0,197* $\psi=0,6$	0,118	0,827	1,5	1,240
4	Internal pressure (0,394)* $\psi=0,6$	0,236	1,655	1,5	2,482
		2,383	16,684	23,408	

2. LC - 2. max pressure		kN/m ²	kN/m'	kN/m'	
1	Permanent	1,541	10,787	1,35	14,562
2	Snow * $\psi=0,5$	0,342	2,391	1,5	3,587
3	Wind (I)	0,197	1,378	1,5	2,066
4	Internal pressure	0,394	2,758	1,5	4,137
		2,376	16,631	23,328	

4. LC - suction		kN/m ²	kN/m'	kN/m'	
1	Permanent	0,541	3,787	1	0,541
2	External wind (H)	-0,689	-4,822	1,5	-1,033



3	Internal suction	-0,541	-3,787	1,5	-0,812
		-0,689	-4,822		-1,304

Table 8.3-1 Load combination on trusses

8.4. Preliminary verification in SCIA Engineer

A preliminary design of the profile will be done in the SCIA Engineer software, to choose the most suitable truss geometry. In particular, cold formed square hollow section will be used. The following table compares the weight of the selected in the previous chapters truss variants. To predict the weight of trusses, the same profile will be used for all diagonal (vertical) members. The S355 steel class will be used.

S355	V1	V2	V3	V4	V5
Height in the middle [m]	1,5	1,7	2	2,5	3
Upper chord profile	200/12	200/10	200/8	180/8	180/6,3
Bottom chord profile	150/10	150/8	150/8	140/6,3	140/5
Diagonal members profile	90/6,3	90/6,3	90/6,3	100/6,3	100/6,3
Weight of the truss [t]	3,854	3,462	3,284	3,169	3,086
Deflection [mm]	102,6	95,0	77,8	64,0	57,1

Table 8.4-1 Comparison variants of trusses

The data about the weight and height of the trusses is also shown in the following diagram:

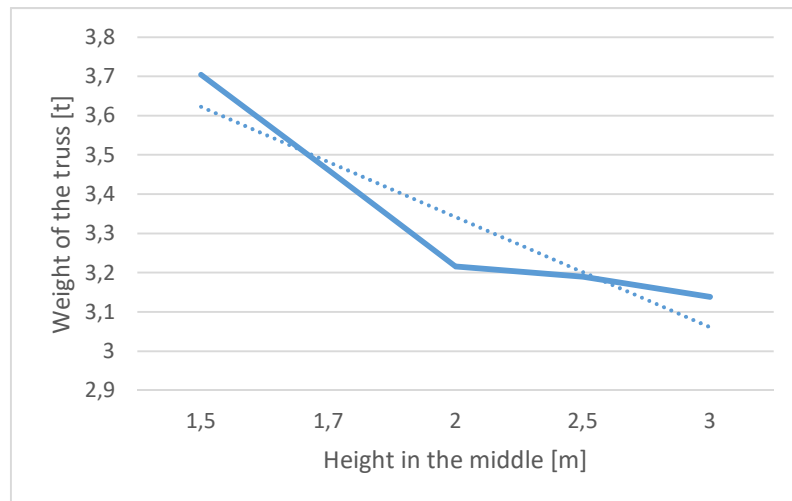

Figure 8.4-1 Weight dependence on truss heights



As can be seen from the graph (Figure 8.4-1), we can see a considerable reduction in the weight of the trusses when they reach a height of about 2 meters.

The 2 m height in the middle of the truss was chosen for reference frame.

8.5. Statical model

8.5.1. Hinged truss

The frame is supported by pinned supports. Columns are hinged too.

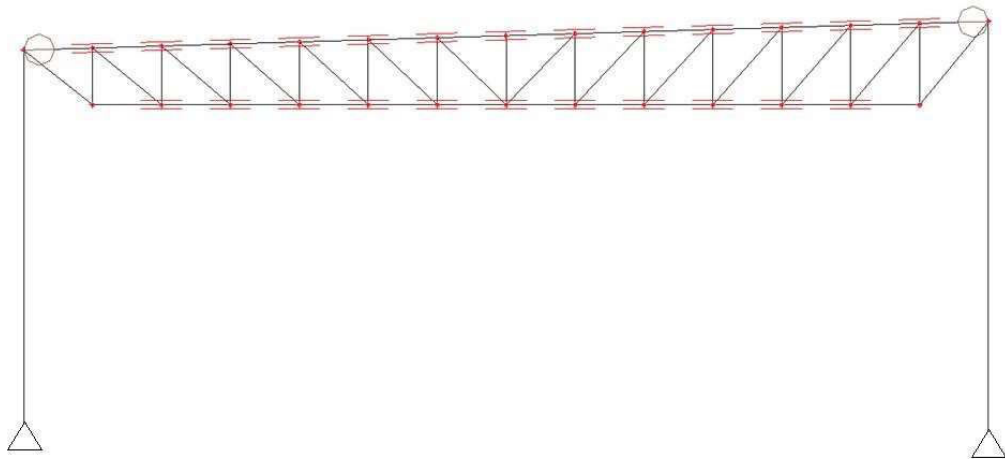

Figure 8.5-1 Statical model of the truss

The stiffness in the lateral direction ensures the vertical stiffener placed in the administrative part of the object (see drawings).



8.6. Final geometry of the reference truss

Based on the considerations in the previous chapters, the following truss were chosen as a reference truss for this thesis:

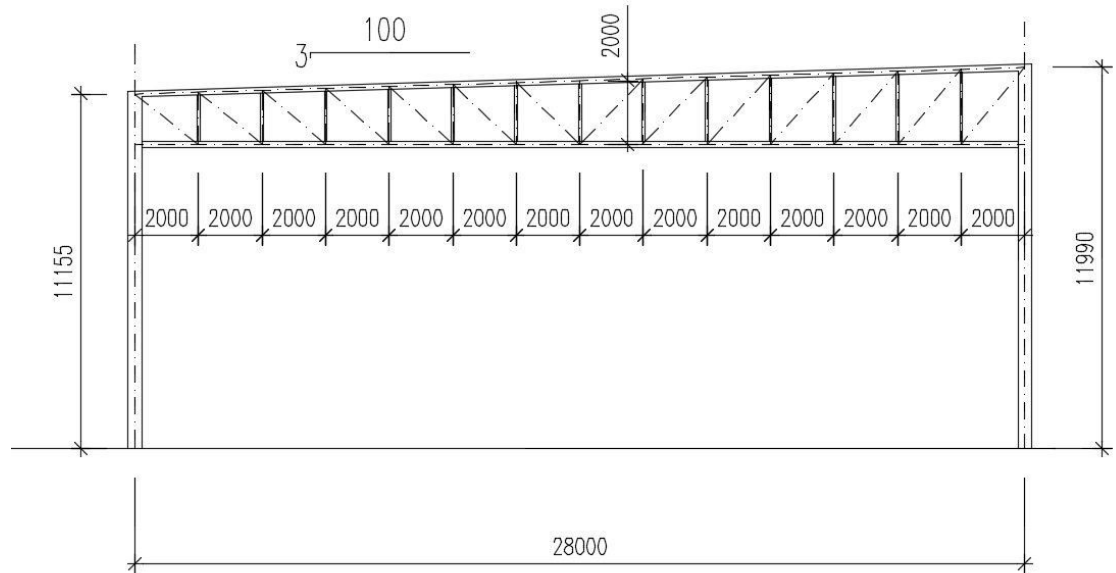

9. Detailed truss design

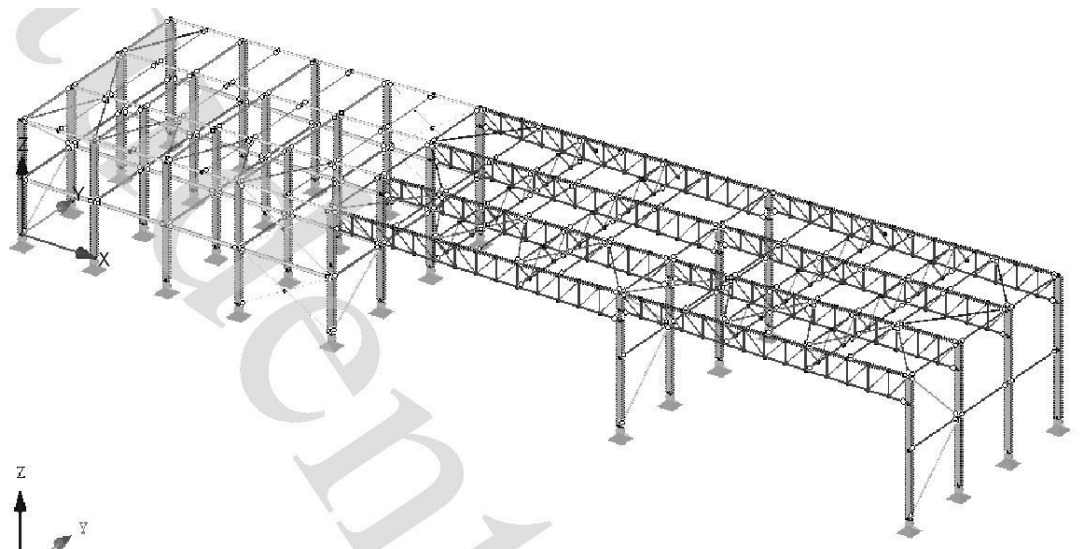

Figure 8.6-1 3D model, part of the object

Detailed design refers to design of profiles, joints and connections. Connections have an essential role on the final decision of member design and cross sectional properties but also on costs.



In previous chapter material costs are calculated for several height of trusses designs based on their self-weight. The chosen design (i.e. hybrid design of a truss) is designed in more detail, in this chapter. Rectangular hollow section (RHS) members are considered and design of connections is performed for adequate strength and fatigue. All the truss designs are made according to European standards.

9.1. Global analysis

For the calculation of internal forces, elastic global analysis is used. This requires that the stresses (from loading) are limited to the yield strength of the material.

For calculating the resistance, plastic or elastic cross sectional properties may be used depending on the classification of steel members [EN 1993-1-1, EN 1993-2].

The internal forces and moments may generally be determined using second-order analysis, taking into account the influence of the deformation of the structure (geometrically nonlinear analysis with sway imperfections only):

- Sway imperfections only
- Buckling covering by reduction factor χ
- Interactions factor

9.2. Columns imperfection

In all load cases, column imperfection according to EN 1993-1-1 (Eurocode 3), will be included.

$$\Phi_i = \Phi_0 \cdot \alpha_h \cdot \alpha_m$$

$$\Phi_0 = 1/200$$

$$\alpha_h = \frac{2}{\sqrt{H}} \begin{cases} > \frac{2}{3} \\ < 1,0 \end{cases}$$

$$\alpha_m = \sqrt{0,5 \cdot \left(1 + \frac{1}{m}\right)}$$

Imperfection towards Y:

$$m = 4 \text{ — is the number of columns in a row}$$

$$H = 12,846 \text{ m}$$



$$\alpha_h = 0,667$$

$$\alpha_m = 0,791$$

$$\Phi_i = 0,002635$$

Imperfection towards X:

$$m = 7 \text{ — is the number of columns in a row}$$

$$H = 12,846 \text{ m}$$

$$\alpha_h = 0,667$$

$$\alpha_m = 0,756$$

$$\Phi_i = 0,002520$$

The rotation calculation was performed in the Dlubal RFEM software and automatically included in the individual load combinations.

9.3. Imperfection for analysis of bracing systems

In the analysis of bracing systems which are required to provide lateral stability within the length of beams or compression members the effects of imperfections should be included by means of an equivalent geometric imperfection of the members to be restrained, in the form of an initial bow imperfection [4]:

$$e_0 = a_m \cdot \frac{L}{500}$$

Where:

$$L = 28 \text{ m is the span of the bracing system}$$

$$a_m = \sqrt{0,5 \cdot \left(1 + \frac{1}{m}\right)}$$

$$m = 4 \text{ — is the number of members to be restrained}$$

$$a_m = 0,791$$

$$e_0 = 0,791 \cdot \frac{28000}{500} = 44,3 \text{ mm}$$

$$\frac{L}{e_0} = \frac{28000}{44,3} = 632,4$$



9.4. Combination of used load cases

Load cases:

Load	Load Case	Value on the roof	Value on the wall		
Case	Description	[kN/m ²]	[kN/m ²]	Action Category	Comment
LC1	Self-weight	Automatically generated		Permanent	
LC2	Roof and walls	3,787	2,1	Permanent	
LC3	Technology	7		Permanent	
LC4	Longitudinal wind	1,379	3,44	Wind	longitudinal wind (pressure on the roof)
LC5	Transverse wind X+	-1,379	2,065	Wind	transverse wind (suction on the roof)
LC6	Transverse wind X-	-1,379; -4,823; -6,202	-4,823	Wind	transverse wind (suction on the roof)
LC7	Snow	3,416		Snow (H ≤ 1000 m a.s.l.)	
LC8	Internal forces Y	2,758	-2,758	Wind	internal suction from the longitudinal wind
LC9	Internal forces +X	3,787	3,787	Wind	internal pressure from the transverse wind
LC10	Internal forces -X	1,645	-1,645	Wind	internal pressure from the transverse wind
LC11	Imperfection towards +Y			Imperfection	
LC12	Imperfection towards +X			Imperfection	
LC13	Imperfection towards -X			Imperfection	

Load combinations for ULS:

CO1(ULS max pressure 1): $1,35 \cdot (LC1+LC2+LC3)+1,5 \cdot LC7+0,9 \cdot (LC4+LC7)+1,0 \cdot LC11$

CO2(ULS max pressure 2): $1,35 \cdot (LC1+LC2+LC3)+0,75 \cdot LC7+1,5 \cdot (LC4+LC7)+1,0 \cdot LC11$

CO3(ULS max suction): $1,0 \cdot (LC1+LC2)+1,5 \cdot (LC5+LC9)+1,0 \cdot LC12$

CO4(ULS max suction): $1,0 \cdot (LC1+LC2)+1,5 \cdot LC6+1,0 \cdot LC13$

CO5(ULS wind X+): $1,35 \cdot (LC1+LC2+LC3)+0,9 \cdot (LC5+LC9)+1,5 \cdot LC7 +1,0 \cdot LC12$

CO6(ULS wind X+): $1,35 \cdot (LC1+LC2+LC3)+1,5 \cdot (LC5+LC9)+0,75 \cdot LC7 +1,0 \cdot LC12$

CO7(ULS wind X-): $1,35 \cdot (LC1+LC2+LC3)+0,9 \cdot (LC10+LC13)+1,5 \cdot LC7 +1,0 \cdot LC13$

CO8(ULS wind X-): $1,35 \cdot (LC1+LC2+LC3)+1,5 \cdot (LC10+LC13)+0,75 \cdot LC7 +1,0 \cdot LC13$



Load combinations for SLS:

$$\text{CO9(ULS max pressure 1): } 1,0 \cdot (\text{LC1} + \text{LC2} + \text{LC3}) + 1,0 \cdot \text{LC7} + 0,6 \cdot (\text{LC4} + \text{LC7}) + 1,0 \cdot \text{LC11}$$

$$\text{CO10(ULS max pressure 2): } 1,0 \cdot (\text{LC1} + \text{LC2} + \text{LC3}) + 0,5 \cdot \text{LC7} + 1,0 \cdot (\text{LC4} + \text{LC7}) + 1,0 \cdot \text{LC11}$$

$$\text{CO11(ULS max suction): } 1,0 \cdot (\text{LC1} + \text{LC2}) + 1,0 \cdot (\text{LC5} + \text{LC9}) + 1,0 \cdot \text{LC12}$$

$$\text{CO12(ULS max suction): } 1,0 \cdot (\text{LC1} + \text{LC2}) + 1,0 \cdot \text{LC6} + 1,0 \cdot \text{LC13}$$

$$\text{CO13(ULS wind X+): } 1,0 \cdot (\text{LC1} + \text{LC2} + \text{LC3}) + 0,6 \cdot (\text{LC5} + \text{LC9}) + 1,0 \cdot \text{LC7} + 1,0 \cdot \text{LC12}$$

$$\text{CO14(ULS wind X+): } 1,0 \cdot (\text{LC1} + \text{LC2} + \text{LC3}) + 1,0 \cdot (\text{LC5} + \text{LC9}) + 0,5 \cdot \text{LC7} + 1,0 \cdot \text{LC12}$$

$$\text{CO15(ULS wind X-): } 1,0 \cdot (\text{LC1} + \text{LC2} + \text{LC3}) + 0,6 \cdot (\text{LC10} + \text{LC13}) + 1,0 \cdot \text{LC7} + 1,0 \cdot \text{LC13}$$

$$\text{CO16(ULS wind X-): } 1,0 \cdot (\text{LC1} + \text{LC2} + \text{LC3}) + 1,0 \cdot (\text{LC10} + \text{LC13}) + 0,5 \cdot \text{LC7} + 1,0 \cdot \text{LC13}$$

9.5. Internal forces in the truss

Internal forces are determined by a nonlinear calculation performed in the Dlubal software (see Appendix).

Internal forces envelope:

Line No.	length L [m]	Forces [kN] N	CO
Upper chord			
	28,013	155,214	CO 3
	28,013	-1319,670	CO 1
Lower chord			
	28,000	1251,881	CO 1
	28,000	-106,881	CO 3
Diagonals			
209	2,551	516,409	CO 1
	2,551	-56,750	CO 3
100	1,642	29,905	CO 3
	1,642	-319,349	CO 1

Table 9.5-1 Internal forces envelope



9.6. Truss members design S355

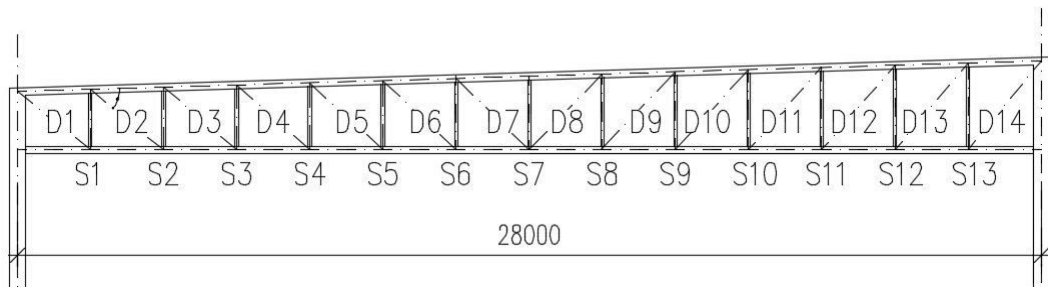

Table 9.6-1 Diagonal and vertical members' numbering

9.6.1. Tensile members profile design

$$f_y = 355 \text{ MPa}$$

$$E = 210 \text{ GPa}$$

$$A_{min,req} = \frac{N_{Ed}}{f_y}$$

	Member	L length	Forces	Strength	Amin,req	Profile	A	Nt,Rd		
	No.	[m]	N _{Ed} [kN]	f _y [MPa]	[mm]	SHS	[mm]	[kN]		
Lower chord	674	28,00	1251,88	355	3526,43	140x8	4160	1476,8	0,85	OK
Diagonal D1	205	2,551	516,41	355	1454,67	90x8	2560	908,8	0,57	OK
Diagonal D2	373	2,588	406,27	355	1144,43	70x5	1270	450,85	0,90	OK
Diagonal D3	245	2,627	311,20	355	876,62	60x5	1070	379,85	0,82	OK
Diagonal D4	319	2,667	214,22	355	603,43	50x4	719	255,245	0,84	OK
Diagonal D5	402	2,707	133,37	355	375,68	40x4	559	198,445	0,67	OK
Diagonal D6	599	2,748	54,31	355	152,98	40x4	559	198,445	0,27	OK
Diagonal D7	1099	2,790	1,65	355	4,64	40x4	559	198,445	0,01	OK
Diagonal D8	772	2,876	90,60	355	255,20	40x4	559	198,445	0,46	OK
Diagonal D9	1606	2,920	152,44	355	429,40	50x4	719	255,245	0,60	OK
Diagonal D10	1170	2,964	216,98	355	611,22	50x4	719	255,245	0,85	OK
Diagonal D11	1108	3,009	274,99	355	774,62	60x4	879	312,045	0,88	OK
Diagonal D12	2227	3,055	333,62	355	939,78	70x5	1270	450,85	0,74	OK
Diagonal D13	1370	3,101	384,44	355	1082,92	80x5	1470	521,85	0,74	HE
Diagonal D14	1481	3,147	441,67	355	1244,15	90x5	1670	592,85	0,74	OK

Table 9.6-2 Tensile members profile design



9.6.2. Pressed vertical members' design

The buckling length L_{cr} of a hollow section chord member will be taken as $0,9L$ for both in-plane and out-of-plane buckling (according to Annex BB1 Eurocode 3 [4]).

$$f_y = 355 \text{ MPa}$$

$$E = 210 \text{ GPa}$$

$$L_{cr} = 0,9L \text{ — for hollow-section chords and vertical members}$$

$$\lambda_1 = \pi \cdot \sqrt{\frac{E}{f_y}} = \pi \cdot \sqrt{\frac{210000}{355}} = 76,41$$

$$\lambda = \frac{L_{cr}}{i}$$

$$\lambda_{rel} = \frac{\lambda}{\lambda_1}$$

$$\phi = 0,5 \cdot [1 + \alpha(\bar{\lambda} - 0,2) + \bar{\lambda}^2]$$

$$\alpha = 0,49 \text{ — buckling curve C for cold formed hollow-section}$$

$$\chi = \frac{1}{\phi + \sqrt{\phi^2 - \bar{\lambda}^2}}$$

$$N_{b,Rd} = \chi \cdot A \cdot \frac{f_y}{\gamma_{M1}}$$

	Member	Forces	Length	L_{cr}	Profile	A	λ	χ	f_y	$N_{b,Rd}$	N_{Ed}/N_{Rd}	
	No.	[kN]	[m]	[m]	SHS	[mm]	[-]	[-]	[MPa]	[kN]		
S1	100	-319,35	1,642	1,478	90x5	1670	42,8	0,808	355	479,313	0,666	OK
D1	205	-46,75	2,551	2,296	90x8	2560	69,2	0,597	355	542,318	0,086	OK
S2	221	-258,93	1,703	1,533	70x5	1270	58,1	0,687	355	309,91	0,835	OK
D3	245	-23,48	2,627	2,364	60x5	1070	106,0	0,354	355	134,418	0,175	OK
S3	284	-203,93	1,764	1,588	60x5	1070	71,2	0,580	355	220,492	0,925	OK
D4	319	-18,70	2,667	2,400	50x4	719	129,0	0,260	355	66,489	0,281	OK
D2	373	-33,95	2,588	2,329	70x5	1270	88,2	0,456	355	205,578	0,165	OK
D5	402	-10,06	2,707	2,436	40x4	559	168,0	0,166	355	33,0175	0,305	OK
S5	494	-93,33	1,885	1,697	50x4	719	91,2	0,437	355	111,489	0,837	OK
S4	539	-144,99	1,824	1,642	60x5	1070	73,6	0,561	355	213,264	0,680	OK
D6	599	-6,80	2,748	2,473	40x4	559	170,6	0,162	355	32,1563	0,211	OK
S6	654	-41,77	1,945	1,751	40x4	559	120,7	0,290	355	57,544	0,726	OK
D8	772	-7,82	2,876	2,588	40x4	559	178,5	0,150	355	29,6689	0,264	OK
S7	823	-56,98	2,006	1,805	50x4	719	97,1	0,402	355	102,504	0,556	OK



S8	830	-114,72	2,067	1,860	60x5	1070	83,4	0,489	355	185,613	0,618	OK
S10	1064	-206,85	2,188	1,969	70x5	1270	74,6	0,554	355	249,713	0,828	OK
D7	1099	-15,49	2,790	2,511	40x4	559	173,2	0,158	355	31,3076	0,495	OK
D11	1108	-22,06	3,009	2,708	60x4	879	119,3	0,295	355	92,1991	0,239	OK
D10	1170	-15,22	2,964	2,668	50x4	719	143,4	0,219	355	55,796	0,273	OK
S13	1316	-338,58	2,369	2,132	90x5	1670	61,8	0,657	355	389,284	0,870	OK
S11	1345	-252,39	2,248	2,023	80x5	1470	66,3	0,620	355	323,3	0,781	OK
D13	1370	-33,59	3,101	2,791	80x5	1470	91,5	0,435	355	226,973	0,148	OK
D14	1481	-40,92	3,147	2,832	90x5	1670	82,1	0,498	355	295,257	0,139	OK
S9	1604	-161,92	2,127	1,914	70x4	1040	71,4	0,579	355	213,619	0,758	OK
D9	1606	-15,14	2,920	2,628	50x4	719	141,3	0,224	355	57,2201	0,265	OK
S12	1877	-293,90	2,309	2,078	80x5	1470	68,1	0,605	355	315,689	0,931	OK
D12	2227	-27,11	3,055	2,750	70x5	1270	104,1	0,363	355	163,779	0,165	OK

Table 9.6-3 Diagonal and vertical members' design

9.6.3. Upper chord design

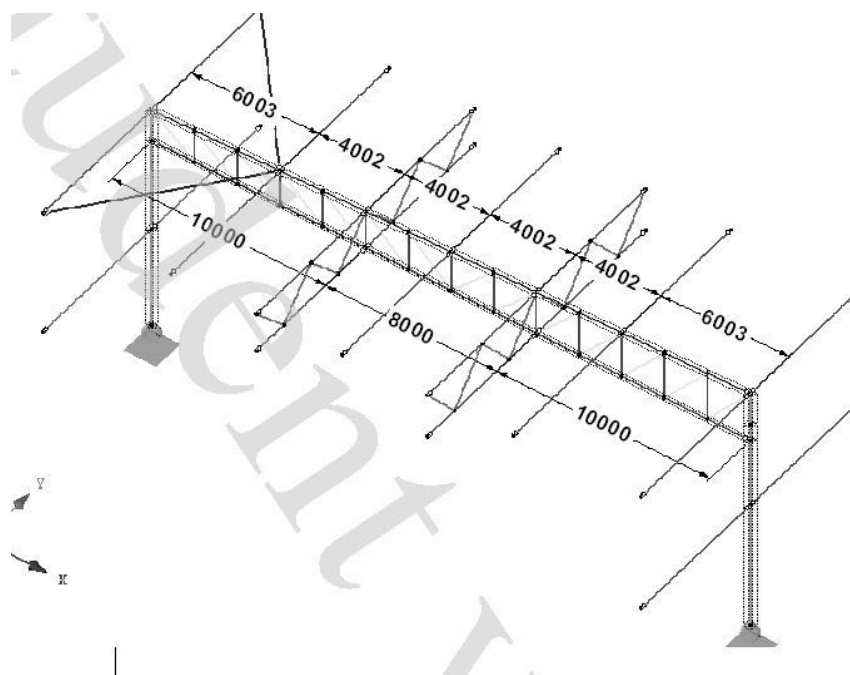

Figure 9.6-1 Buckling length of the upper and lower chords



RFEM5

CO1: ULS max pressure 1

Internal forces - N

	x [m]	N [kN]
max	-	-
min	10.005	-1319.666

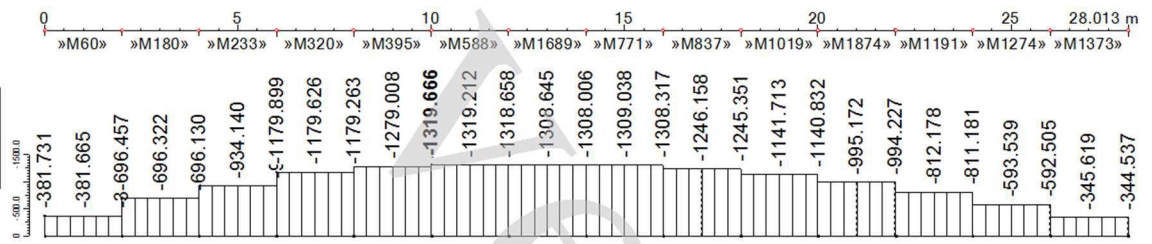

RFEM5

CO1: ULS max pressure 1

Internal forces - My

	x [m]	My [kNm]
max	9.004	15.290
min	26.012	-5.551

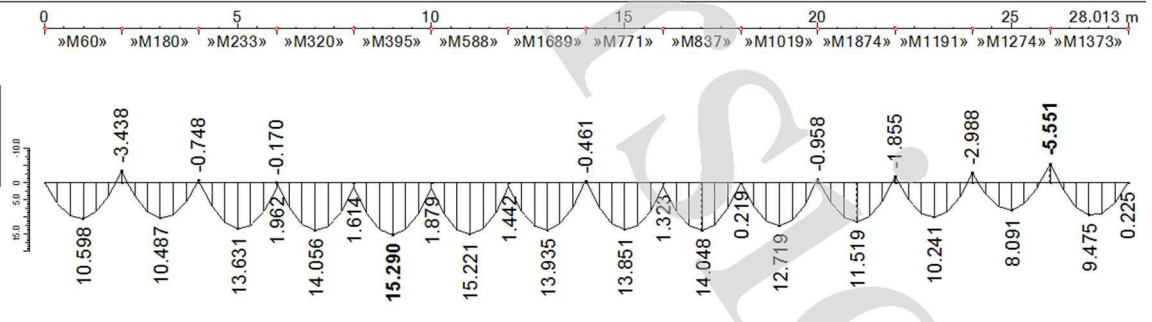

Figure 9.6-2 Internal forces in the upper chord (CO1)

Max. internal forces in the middle of the truss (buckling length in z-direction is 4,02 m):

$$N_{Ed} = -1319,67 \text{ kN}$$

$$M_{Ed,y} = 15,29 \text{ kNm}$$

Max. internal forces in the edge of the truss (buckling length in z-direction is 6,03 m):

$$N_{Ed} = -934,10 \text{ kN}$$

$$M_{Ed,y} = 13,631 \text{ kNm}$$

Internal forces are determined by a nonlinear calculation performed in the Dlubal software.

SHS 180x10:

$$f_y = 355 \text{ MPa}$$

$$E = 210 \text{ GPa}$$

$$h = b = 180 \text{ mm}$$

$$A = 6690 \text{ mm}^2$$

$$W_{pl,y} = W_{pl,z} = 424 \cdot 10^3 \text{ mm}^3$$



$$I_y = I_z = 31,93 \cdot 10^6 \text{ mm}^4$$

$$i = 69,1 \text{ mm}$$

Resistance:

$$N_{Rd} = A \cdot f_y / \gamma_{M0} = 6690 \cdot 355 / 1,0 = 2375 \text{ kN}$$

$$M_{Rd} = W_{pl} \cdot f_y / \gamma_{M0} = 424 \cdot 10^3 \cdot 355 / 1,0 = 150,52 \text{ kNm}$$

Buckling in y-direction. Input values for stability check:

$$L_y = 2,001 \text{ m}$$

$$L_{cr,y} = 0,9 \cdot 2,001 = 1,8 \text{ m}$$

$$\lambda_1 = \pi \cdot \sqrt{\frac{E}{f_y}} = \pi \cdot \sqrt{\frac{210000}{355}} = 76,41$$

$$\lambda_y = \frac{L_{cr,y}}{i} = \frac{1802}{69,1} = 26,1$$

$$\bar{\lambda}_y = \frac{\lambda_y}{\lambda_1} = 26,1 / 76,41 = 0,341$$

$$\phi = 0,5 \cdot [1 + \alpha(\bar{\lambda} - 0,2) + \bar{\lambda}^2]$$

$\alpha = 0,49$ — buckling curve C for cold formed hollow-section

$$\phi = 0,5 \cdot [1 + 0,49(0,341 - 0,2) + 0,341^2] = 0,59$$

$$\chi_y = \frac{1}{\phi + \sqrt{\phi^2 - \bar{\lambda}_y^2}} = \frac{1}{0,59 + \sqrt{0,59^2 - 0,341^2}} = 0,93$$

Buckling in z-direction (in the middle of the truss):

$$L_z = 4,002 \text{ m}$$

$$L_{cr,z} = 0,9 \cdot 4,002 = 3,602 \text{ m}$$

$$\lambda_z = \frac{L_{cr,z}}{i} = \frac{3602}{69,1} = 52,1$$

$$\bar{\lambda}_z = \frac{\lambda_z}{\lambda_1} = 52,1 / 76,41 = 0,68$$

$$\phi = 0,5 \cdot [1 + \alpha(\bar{\lambda} - 0,2) + \bar{\lambda}^2]$$



$\alpha = 0,49$ — buckling curve C for cold formed hollow-section

$$\phi = 0,5 \cdot [1 + 0,49(0,68 - 0,2) + 0,68^2] = 0,628$$

$$\chi_z = \frac{1}{\phi + \sqrt{\phi^2 - \bar{\lambda}_z^2}} = \frac{1}{0,628 + \sqrt{0,628^2 - 0,68^2}} = 0,74$$

$\chi_{LT} = 1,0$ — for hollow-section profiles

For the determination of the interaction factors k_{ij} , Czech National Appendix B Eurocode 3 [6] will be used.

Buckling in y-direction:

$$M_h = 4,462 \text{ kNm}$$

$$M_s = 15,290 \text{ kNm}$$

$$\psi \cdot M_h = 1,036 \text{ kNm}$$

$$\alpha_h = M_h / M_s = 0,29$$

$$\psi = 0,23$$

$$C_{my} = 0,95 + 0,05 \cdot \alpha_h = 0,95 + 0,05 \cdot 0,29 = 0,96$$

$$k_{yy} = C_{my} \left(1 + (\bar{\lambda}_y - 0,2) \frac{N_{Ed}}{\chi_y \cdot A \cdot f_y / \gamma_{M0}} \right) = 0,965 \left(1 + (0,302 - 0,2) \frac{1319,67 \cdot 10^3}{0,93 \cdot 6690 \cdot 355/1} \right) = 1,05$$

$$k_{yy} \leq C_{my} \left(1 + 0,8 \frac{N_{Ed}}{\chi_y \cdot N_{Rk} / \gamma_{M1}} \right) = 0,965 \left(1 + 0,8 \frac{1319,67 \cdot 10^3}{0,93 \cdot 6690 \cdot 355/1} \right) = 1,43$$

$$k_{yy} = 1,05$$

$$k_{zy} = 0,6 \cdot k_{yy} = 0,628$$

ULS verification:

$$\begin{aligned} & \frac{N_{Ed}}{\chi_y \cdot N_{Rk} / \gamma_{M1}} + k_{yy} \frac{M_{y,Ed}}{\chi_{LT} \cdot M_{y,Rk} / \gamma_{M1}} \\ &= \frac{1319,67 \cdot 10^3}{0,93 \cdot 2375 \cdot 10^3 / 1} + 1,05 \frac{15,29 \cdot 10^6}{1,0 \cdot 150,52 \cdot 10^6 / 1} \\ &= 0,6 + 0,11 = 0,705 \leq 1 \end{aligned}$$

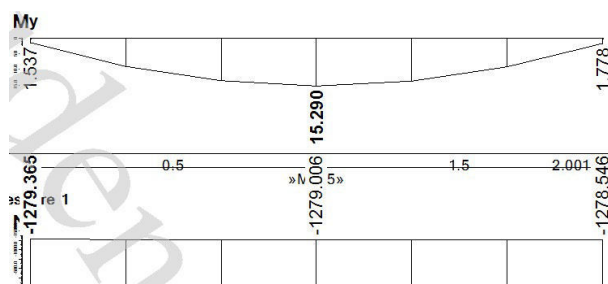

Figure 9.6-3 Internal forces



$$\begin{aligned}\frac{N_{Ed}}{\chi_z \cdot N_{Rk}/\gamma_{M1}} + k_{zy} \frac{M_{y,Ed}}{\chi_{LT} \cdot M_{y,Rk}} \\ &= \frac{1319,67 \cdot 10^3}{0,74 \cdot 2375 \cdot 10^3/1} + 0,628 \frac{15,29 \cdot 10^6}{1,0 \cdot 150,52 \cdot 10^6/1} \\ &= \mathbf{0,76 + 0,06 = 0,819 \leq 1}\end{aligned}$$

OK

Buckling in z-direction (in the edge of the truss):

$$N_{Ed} = -934,1 \text{ kN}$$

$$M_{Ed,y} = 13,631 \text{ kNm}$$

$$L_z = 6,003 \text{ m}$$

$$L_{cr,z} = 0,9 \cdot 6,003 = 5,403 \text{ m}$$

$$\lambda_z = \frac{L_{cr,z}}{i} = \frac{5,403}{69,1} = 78,2$$

$$\bar{\lambda}_z = \frac{\lambda_z}{\lambda_1} = 78,2/76,41 = 1,02$$

$$\phi = 0,5 \cdot [1 + \alpha(\bar{\lambda} - 0,2) + \bar{\lambda}^2]$$

$$\alpha = 0,49 \text{ — buckling curve C for cold formed hollow-section}$$

$$\phi = 0,5 \cdot [1 + 0,49(1,02 - 0,2) + 1,02^2] = 1,23$$

$$\chi_z = \frac{1}{\phi + \sqrt{\phi^2 - \bar{\lambda}_z^2}} = \frac{1}{1,23 + \sqrt{1,23^2 - 1,02^2}} = 0,527$$

For the determination of the interaction factors k_{ij} , Appendix B will be used.

Buckling in y-direction:

$$M_h = 1,907 \text{ kNm}$$

$$M_s = 13,631 \text{ kNm}$$

$$\psi \cdot M_h = -0,748 \text{ kNm}$$

$$\alpha_h = M_h/M_s = 0,14$$

$$\psi = -0,39$$

$$C_{my} = 0,95 + 0,05 \cdot \alpha_h = 0,95 + 0,05 \cdot 0,14 = 0,957$$

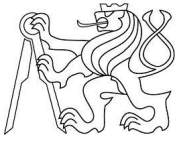

$$\begin{aligned}k_{yy} &= C_{my} \left(1 + (\bar{\lambda}_y - 0,2) \frac{N_{Ed}}{\chi_y \cdot A \cdot f_y / \gamma_{M0}} \right) \\ &= 0,965 \left(1 + (0,341 - 0,2) \frac{934,10 \cdot 10^3}{0,93 \cdot 6690 \cdot 355/1} \right) = 1,014\end{aligned}$$

$$\begin{aligned}k_{yy} &\leq C_{my} \left(1 + 0,8 \frac{N_{Ed}}{\chi_y \cdot N_{Rk} / \gamma_{M1}} \right) = 0,965 \left(1 + 0,8 \frac{934,10 \cdot 10^3}{0,93 \cdot 6690 \cdot 355/1} \right) \\ &= 1,281\end{aligned}$$

$$\mathbf{k_{yy} = 1,014}$$

$$\mathbf{k_{zy} = 0,6 \cdot k_{yy} = 0,609}$$

ULS verification:

$$\begin{aligned}\frac{N_{Ed}}{\chi_y \cdot N_{Rk} / \gamma_{M1}} + k_{yy} \frac{M_{y,Ed}}{\chi_{LT} \cdot M_{y,Rk} / \gamma_{M1}} \\ &= \frac{934,10 \cdot 10^3}{0,93 \cdot 2375 \cdot 10^3/1} + 1,014 \frac{13,631 \cdot 10^6}{1,0 \cdot 150,52 \cdot 10^6/1} \\ &= 0,424 + 0,092 = \mathbf{0,516 \leq 1}\end{aligned}$$

$$\begin{aligned}\frac{N_{Ed}}{\chi_z \cdot N_{Rk} / \gamma_{M1}} + k_{zy} \frac{M_{y,Ed}}{\chi_{LT} \cdot M_{y,Rk}} \\ &= \frac{934,10 \cdot 10^3}{0,527 \cdot 2375 \cdot 10^3/1} + 0,609 \frac{13,631 \cdot 10^6}{1,0 \cdot 150,52 \cdot 10^6/1} \\ &= \mathbf{0,75 + 0,06 = 0,802 \leq 1}\end{aligned}$$

OK



9.6.4. Lower chord profile verification (in pressure)

The lower chord of the truss is predominantly tensile, but in the 3rd load combination, the lower chord is pressed. The profile was designed in the Table 9.6-2 (page 52).

RFEM5
CO3: ULS max suction 1

Internal forces - N

	x [m]	N [kN]
max	2.000	0.001
min	12.000	-106.881

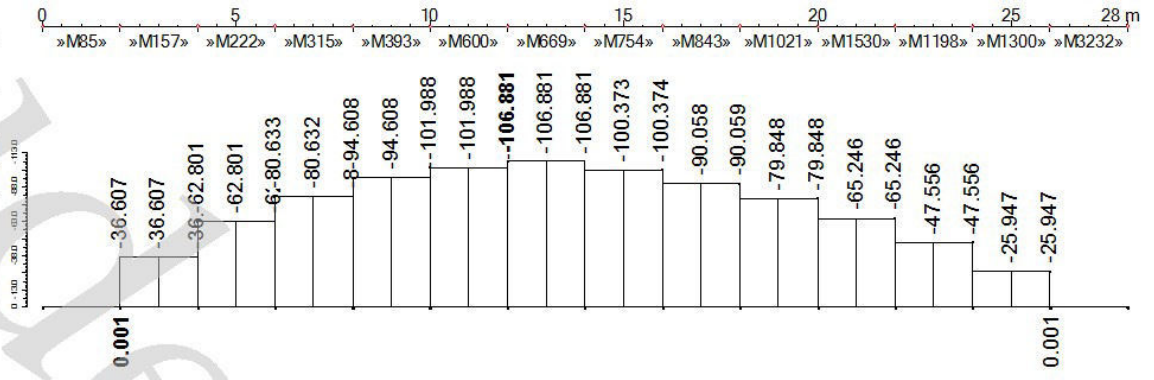

Figure 9.6-4 Internal forces in the lower chord CO3

$$N_{Ed} = 106,881 \text{ kN}$$

$$M_{Ed,y} \approx 0 \text{ kNm}$$

Internal forces are determined by a nonlinear calculation performed in the Dlubal software.

SHS 140x8:

$$f_y = 355 \text{ MPa}$$

$$E = 210 \text{ GPa}$$

$$h = b = 140 \text{ mm}$$

$$A = 4160 \text{ mm}^2$$

$$i = 53,6 \text{ mm}$$

Resistance:

$$N_{Rd} = A \cdot f_y / \gamma_{M0} = 4160 \cdot 355 / 1,0 = 1476,8 \text{ kN}$$

Buckling in y-direction. Input values for stability check:

$$L_y = 2,0 \text{ m}$$

$$L_{cr,y} = 0,9 \cdot 2,0 = 1,8 \text{ m}$$



$$\lambda_1 = \pi \cdot \sqrt{\frac{E}{f_y}} = \pi \cdot \sqrt{\frac{210000}{355}} = 76,41$$

$$\lambda_y = \frac{L_{cr,y}}{i} = \frac{1800}{53,4} = 33,6$$

$$\bar{\lambda}_y = \frac{\lambda_y}{\lambda_1} = 33,6/76,41 = 0,439$$

$$\begin{aligned}\phi &= 0,5 \cdot [1 + \alpha(\bar{\lambda} - 0,2) + \bar{\lambda}^2] = 0,5 \cdot [1 + 0,49(0,439 - 0,2) + 0,439^2] \\ &= 0,655\end{aligned}$$

$$\chi_y = \frac{1}{\phi + \sqrt{\phi^2 - \bar{\lambda}_y^2}} = \frac{1}{0,655 + \sqrt{0,655^2 - 0,439^2}} = 0,876$$

$$\frac{N_{Ed}}{\chi_y \cdot N_{Rk}/\gamma_{M1}} = \frac{106,88}{0,876 \cdot 1476,8/1,0} = \mathbf{0,083} \leq \mathbf{1}$$

OK

Buckling in z-direction (in the middle of the truss):

$$N_{Ed} = 106,88 \text{ kN}$$

$$L_z = 8,0 \text{ m}$$

$$L_{cr,z} = 0,9 \cdot 8,0 = 7,2 \text{ m}$$

$$\lambda_z = \frac{L_{cr,z}}{i} = \frac{7200}{53,6} = 134,3$$

$$\bar{\lambda}_z = \frac{\lambda_z}{\lambda_1} = 134,3/76,41 = 1,758$$

$$\begin{aligned}\phi &= 0,5 \cdot [1 + \alpha(\bar{\lambda} - 0,2) + \bar{\lambda}^2] = 0,5 \cdot [1 + 0,49(1,758 - 0,2) + 1,758^2] \\ &= 2,427\end{aligned}$$

$$\chi_z = \frac{1}{\phi + \sqrt{\phi^2 - \bar{\lambda}_z^2}} = \frac{1}{0,781 + \sqrt{0,781^2 - 0,604^2}} = 0,244$$

$$\frac{N_{Ed}}{\chi_z \cdot N_{Rk}/\gamma_{M1}} = \frac{106,88}{0,244 \cdot 1476,8/1,0} = \mathbf{0,297} \leq \mathbf{1}$$

OK



Buckling in z-direction (in the edge of the truss):

$$N_{Ed} = 94,608 \text{ kN}$$

$$L_z = 10,0 \text{ m}$$

$$L_{cr,z} = 0,9 \cdot 10,0 = 9,0 \text{ m}$$

$$\lambda_z = \frac{L_{cr,z}}{i} = \frac{9000}{53,6} = 167,9$$

$$\bar{\lambda}_z = \frac{\lambda_z}{\lambda_1} = 167,9/76,41 = 2,197$$

$$\begin{aligned} \phi &= 0,5 \cdot [1 + \alpha(\bar{\lambda} - 0,2) + \bar{\lambda}^2] = 0,5 \cdot [1 + 0,49(2,197 - 0,2) + 2,197^2] \\ &= 3,404 \end{aligned}$$

$$\chi_z = \frac{1}{\phi + \sqrt{\phi^2 - \bar{\lambda}_z^2}} = \frac{1}{3,4041 + \sqrt{3,404^2 - 2,197^2}} = 0,167$$

$$\frac{N_{Ed}}{\chi_z \cdot N_{Rk}/\gamma_{M1}} = \frac{94,608}{0,167 \cdot 1476,8/1,0} = \mathbf{0,434} \leq \mathbf{1}$$

OK

9.6.5. Deflection

$$\delta_{lim} = \frac{L}{250} = \frac{28000}{250} = 112 \text{ mm}$$



RC3: Characteristic Values
Global Deformations u-Z
Result Combinations: Max and Min Values

In Y-direction

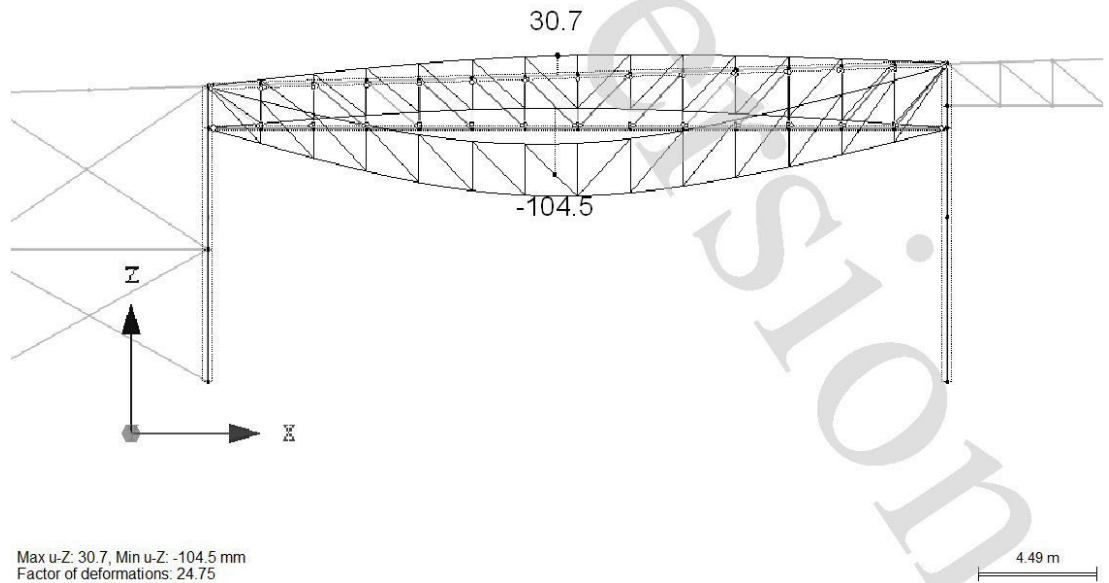

Figure 9.6-5 Global deflection on the truss

$$\delta = 104,5 \text{ mm}$$

$$\delta < \delta_{lim}$$

OK

9.7. Columns

9.7.1. Outer column of the hall

9.7.1.1. Serviceability limit state

First, it is necessary to verify the condition of a permissible horizontal deformation on the columns (HEA340) in software Dlubal RFEM.

In the Czech Republic, it is recommended that the highest values of horizontal deflections δ of building structures be determined as follows:

- Peak of building columns from wind load:

$$\delta_{lim} = \frac{H}{150} = \frac{12846}{150} = 85,64 \text{ mm}$$

- Local deflection of the column:

$$\delta_{lim} = \frac{H}{250} = \frac{12846}{250} = 51,384 \text{ mm}$$

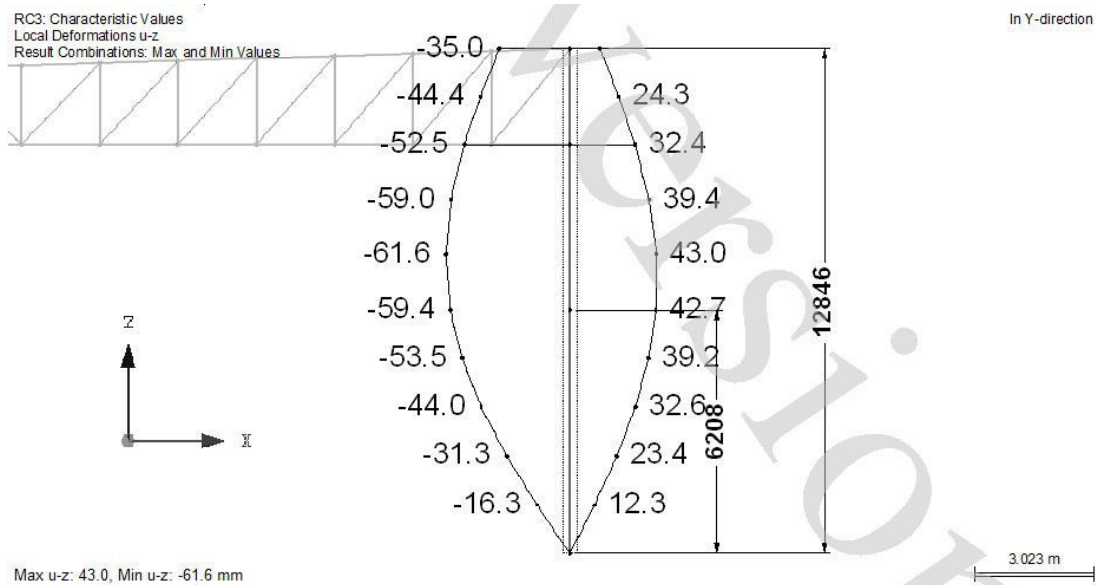

Figure 9.7-1 Deflection on the column (envelope)

Peak of building columns:

$$\delta_{peak} = 35,0 \text{ mm} \leq 85,64 \text{ mm} = \delta_{lim}$$

Local deflection of the column:

$$x(\delta_{local}) = 7,26 \text{ m}$$

$$\delta_{local} = 61,6 - \frac{7,26 \cdot 35,0}{12,846}$$

$$= 41,82 \text{ mm} \leq 51,384 \text{ mm} = \delta_{lim}$$

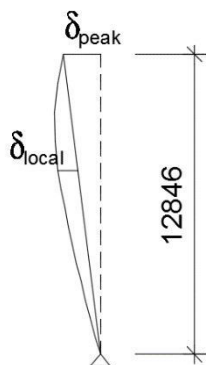

HEA340 is OK for SLS



9.7.1.2. Characteristics of the column and internal forces

The profile of the most stressed column in a row will be designed and used for all columns. Critical load combination is CO2:

RFEM5

CO2: ULS max pressure 2

Internal forces - N

	x [m]	N [kN]
max	--	--
min	12.846	-478.514

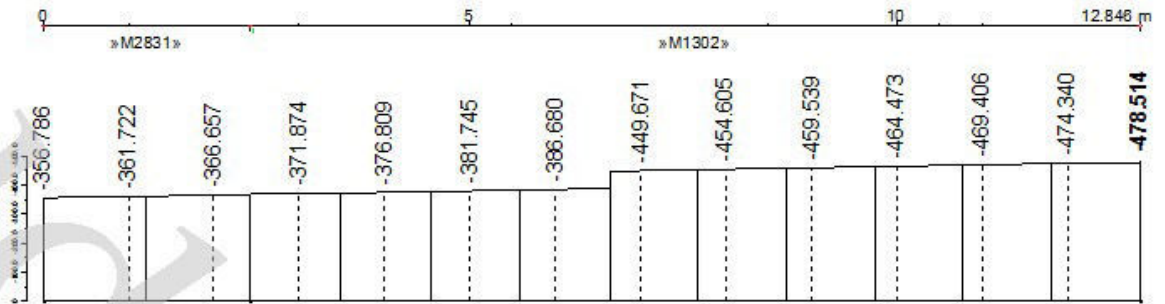

RFEM5

CO2: ULS max pressure 2

Internal forces - My

	x [m]	My [kNm]
max	6.638	22.120
min	0.000	-0.017

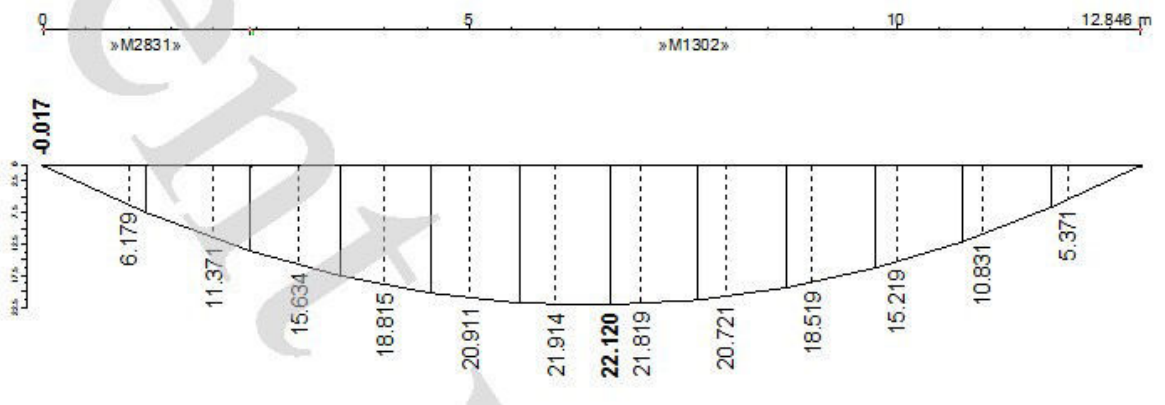

Figure 9.7-2 Internal forces in the column (CO2)

$$L = 12,846 \text{ m}$$

$$N_{Ed,max} = -478,514 \text{ kN}$$

$$M_{Ed,y,max} = 22,120 \text{ kNm}$$

The bending moment M_z may be ignored, because influences the cross-section check to less than 1%.

Profile HEA340 (3rd class in bending):

$$f_y = 355 \text{ MPa}$$

$$A = 13347 \text{ mm}^2$$

$$h = 330 \text{ mm}$$

$$b = 300 \text{ mm}$$



$$I_y = 276,9 \cdot 10^6 \text{ mm}^4$$

$$i_y = 144 \text{ mm}$$

$$W_y = 1678,4 \cdot 10^3 \text{ mm}^3$$

$$W_{pl,y} = 1850,5 \cdot 10^3 \text{ mm}^3$$

$$I_z = 74,36 \cdot 10^6 \text{ mm}^4$$

$$i_z = 75 \text{ mm}$$

$$W_z = 495,7 \cdot 10^3 \text{ mm}^3$$

$$W_{pl,z} = 755,9 \cdot 10^3 \text{ mm}^3$$

$$I_t = 1271,95 \cdot 10^3 \text{ mm}^4$$

$$I_w = 1824 \cdot 10^9 \text{ mm}^4$$

$$\frac{N_{Ed}}{\chi_y \cdot N_{Rd}} + k_{yy} \frac{M_{y,Ed}}{\chi_{LT} \cdot M_{y,Rd}} \leq 1$$

Simple resistance:

$$N_{Rd} = A \cdot f_y / \gamma_{M0} = 4738,3 \text{ kN}$$

$$M_{y,Rd} = W_y \cdot \frac{f_y}{\gamma_{M0}} = 595,82 \text{ kNm}$$

9.7.1.3. Buckling coefficients

Buckling coefficient in y-direction:

$$L_{cr,y} = 1,0 \cdot L = 12,846 \text{ m}$$

$$\lambda_1 = \pi \cdot \sqrt{\frac{E}{f_y}} = \pi \cdot \sqrt{\frac{210000}{355}} = 76,41$$

$$\lambda_y = \frac{L_{cr,y}}{i_y} = \frac{12846}{144} = 89,182$$

$$\bar{\lambda}_y = \frac{\lambda_y}{\lambda_1} = \frac{89,182}{76,41} = 1,167$$

$$\chi_y = \frac{1}{\phi + \sqrt{\phi^2 - \bar{\lambda}^2}}$$



$$\phi = 0,5 \cdot [1 + \alpha(\bar{\lambda} - 0,2) + \bar{\lambda}^2]$$

$\alpha = 0,34$ — buckling curve B for I-shape rolled profile $h/b \leq 1,2$, $t \leq 100$ mm – buckling on y-direction

$$\begin{aligned}\phi &= 0,5 \cdot [1 + \alpha(\bar{\lambda} - 0,2) + \bar{\lambda}^2] = 0,5 \cdot [1 + 0,34(1,167 - 0,2) + 1,167^2] \\ &= 1,346\end{aligned}$$

$$\chi_y = \frac{1}{1,346 + \sqrt{1,346^2 - 1,167^2}} = 0,496$$

Buckling coefficient in z-direction:

$$L_{cr,z} = 1,0 \cdot 6,208 = 6,208 \text{ m}$$

$$\lambda_z = \frac{L_{cr,z}}{i_z} = \frac{6208}{76} = 82,905$$

$$\bar{\lambda}_z = \frac{\lambda_z}{\lambda_1} = \frac{82,905}{76,41} = 1,085$$

$$\chi_z = \frac{1}{\phi + \sqrt{\phi^2 - \bar{\lambda}_z^2}}$$

$$\phi_z = 0,5 \cdot [1 + \alpha(\bar{\lambda}_z - 0,2) + \bar{\lambda}_z^2]$$

$\alpha = 0,49$ — buckling curve C for I-shape rolled profile $h/b \leq 1,2$, $t \leq 100$ mm – buckling on z-direction

$$\begin{aligned}\phi_z &= 0,5 \cdot [1 + \alpha(\bar{\lambda}_z - 0,2) + \bar{\lambda}_z^2] \\ &= 0,5 \cdot [1 + 0,49(1,085 - 0,2) + 1,085^2] = 1,288\end{aligned}$$

$$\chi_z = \frac{1}{1,288 + \sqrt{1,288^2 - 1,085^2}} = 0,492$$

Lateral torsional buckling:

$$L_{cr,LT} = 12,846 \text{ m}$$

$$\kappa_{wt} = \frac{\pi}{k_w \cdot L_{cr,LT}} \cdot \sqrt{\frac{E \cdot I_w}{G \cdot I_t}} = \frac{\pi}{1,0 \cdot 12846} \cdot \sqrt{\frac{210000 \cdot 1824 \cdot 10^9}{81000 \cdot 1271,95 \cdot 10^3}} = 0,472$$

$$k_z = 1$$

$$C_1 = 1,13$$



$$C_2 = 0,46$$

$$z_g = z_a = -150 \text{ mm}$$

$$\zeta_g = \frac{\pi \cdot z_g}{k_z \cdot L_{cr,LT}} \cdot \sqrt{\frac{E \cdot I_z}{G \cdot I_t}} = \frac{\pi \cdot (-150)}{1,0 \cdot 12846} \cdot \sqrt{\frac{210 \cdot 74,36 \cdot 10^6}{81 \cdot 1271,95 \cdot 10^3}} = -0,50$$

$$\begin{aligned} \mu_{cr} &= \frac{C_1}{k_z} \left[\sqrt{1 + \kappa_{wt}^2 + (C_2 \zeta_g - C_3 \zeta_j)^2} - (C_2 \zeta_g - C_3 \zeta_j) \right] = \\ &= \frac{1,13}{1} \sqrt{1 + 0,472^2 + (-0,50 \cdot 0,46 - 0)^2} \\ &\quad - (-0,46 \cdot 0,50) = 1,504 \end{aligned}$$

$$\begin{aligned} M_{cr} &= \mu_{cr} \cdot \frac{\pi}{L_{cr,LT}} \cdot \sqrt{E \cdot I_z \cdot G \cdot I_t} \\ &= 1,487 \\ &\quad \cdot \frac{\pi}{12846} \sqrt{210000 \cdot 74,36 \cdot 10^6 \cdot 81000 \cdot 1271,95 \cdot 10^3} \\ &= 466 \cdot 10^6 \text{ Nmm} \end{aligned}$$

$$\bar{\lambda}_{LT} = \sqrt{\frac{f_y \cdot W_{pl,z}}{M_{cr}}} = \sqrt{\frac{355 \cdot 755,9 \cdot 10^3}{466 \cdot 10^6}} = 0,758$$

$\alpha = 0,21$ — for rolled I-sections $h/b < 2$ according table 6.4 [4]

$$\begin{aligned} \phi_{LT} &= 0,5 \cdot [1 + \alpha(\bar{\lambda} - 0,2) + \bar{\lambda}^2] = 0,5 \cdot [1 + 0,21(0,758 - 0,2) + 0,758^2] \\ &= 0,846 \end{aligned}$$

$$\chi_{LT} = \frac{1}{\phi + \sqrt{\phi^2 - \bar{\lambda}^2}} = \frac{1}{0,846 + \sqrt{0,846^2 - 0,758^2}} = 0,819$$

9.7.1.4. Interaction factors

$$M_{y,Ed} = 22,98 \text{ kNm}$$

$$\psi = 0$$

$$\alpha_h = 0$$

$$C_{my} = 0,95 + 0,05\alpha_h = 0,95$$

$$C_{mLT} = 0,95 + 0,05\alpha_h = 0,95$$



$$\begin{aligned}k_{yy} &= C_{my} \left(1 + (\bar{\lambda}_y - 0,2) \frac{N_{Ed}}{\chi_y \cdot N_{Rk} / \gamma_{M1}} \right) \\ &= 0,95 \left(1 + (1,167 - 0,2) \frac{478,514 \cdot 10^3}{0,496 \cdot 4738,3 \cdot 10^3 / 1} \right) \\ &= 1,135\end{aligned}$$

$$\begin{aligned}k_{yy} &\leq C_{my} \left(1 + 0,8 \frac{N_{Ed}}{\chi_y \cdot N_{Rk} / \gamma_{M1}} \right) \\ &= 0,95 \left(1 + 0,8 \frac{478,514 \cdot 10^3}{0,496 \cdot 4738,3 \cdot 10^3 / 1} \right) = 1,103\end{aligned}$$

$$\mathbf{k_{yy} = 1,103}$$

9.7.1.5. Verification

$$\begin{aligned}\frac{N_{Ed}}{\chi_y \cdot N_{Rd}} + k_{yy} \frac{M_{y,Ed}}{\chi_{LT} \cdot M_{y,Rd}} \\ &= \frac{478,514 \cdot 10^3}{0,430 \cdot 4738,3 \cdot 10^3 / 1} + 1,103 \frac{22,120 \cdot 10^6}{0,792 \cdot 595,82 \cdot 10^6} \\ &= \mathbf{0,202 + 0,049 = 0,251 \leq 1}\end{aligned}$$

The Serviceability limit state is critical for columns.

HEA 340 is OK for outer columns

9.7.2. Inner columns of the hall

The average normal force in the inner column is approximately 720 kN. The column profile of the wall bracing with the highest axial force of 770 kN will be checked. This profile will be used for all columns. The calculation procedure will be similar to the outer column (9.7.2).



9.7.2.1. Serviceability limit state

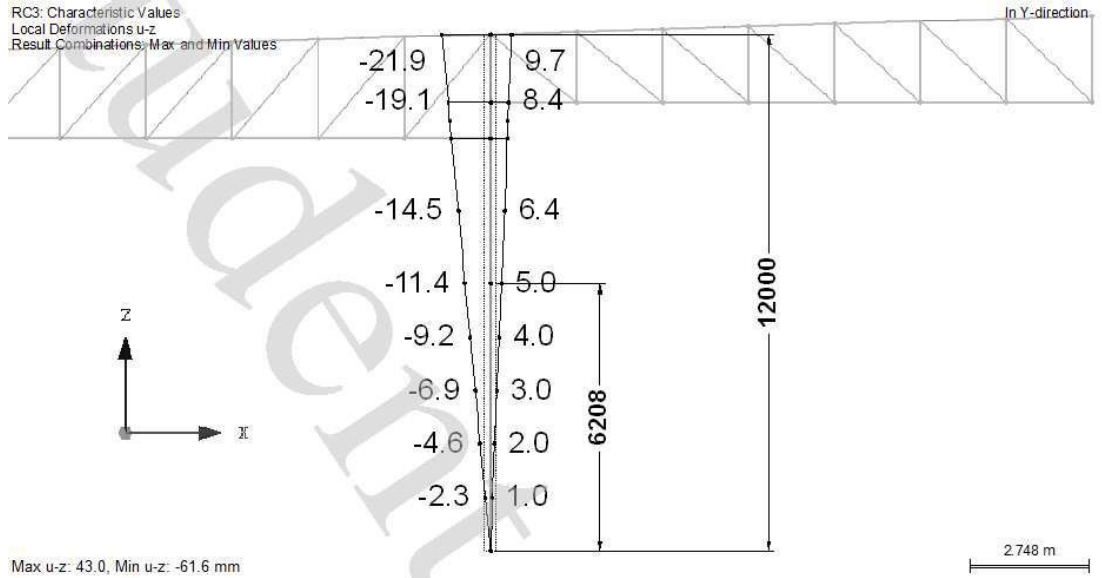

Table 9.7-1 Column deflection

$$\delta_{lim} = \frac{H}{150} = \frac{12000}{150} = 80 \text{ mm}$$

$$\delta = 21,9 \text{ mm} \leq 42,82 \text{ mm}$$

HEA240 is OK

9.7.2.2. Characteristics of the column and internal forces

Maximum axial forces on the column (CO1):

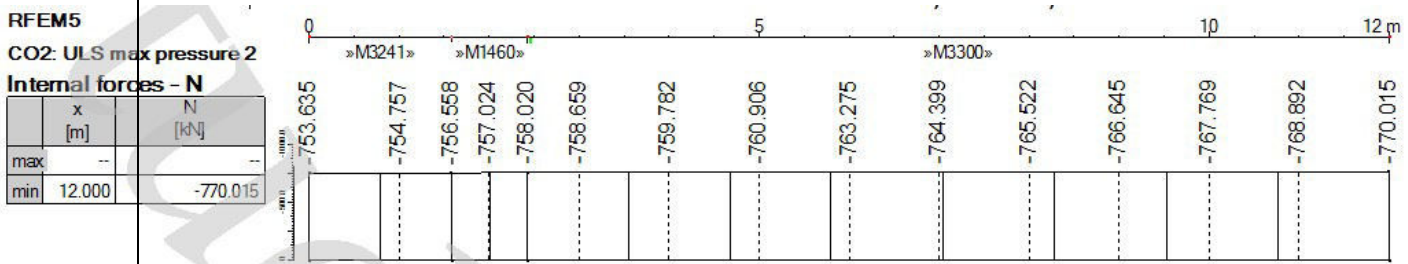

Figure 9.7-3 Internal forces of the column

$$L = 12 \text{ m}$$

$$N_{Ed,max} = -770,015 \text{ kN}$$

Profile HEA260 (3rd class):

$$f_y = 355 \text{ MPa}$$



$$A = 7684 \text{ mm}^2$$

$$h = 230 \text{ mm}$$

$$b = 240 \text{ mm}$$

$$I_y = 77,63 \cdot 10^6 \text{ mm}^4$$

$$i_y = 101 \text{ mm}$$

$$W_{pl,y} = 774,6 \cdot 10^3 \text{ mm}^3$$

$$W_y = 675,1 \cdot 10^3 \text{ mm}^3$$

$$I_z = 27,7 \cdot 10^6 \text{ mm}^4$$

$$i_z = 60 \text{ mm}$$

$$W_z = 230,7 \cdot 10^3 \text{ mm}^3$$

$$W_{pl,z} = 351,7 \cdot 10^3 \text{ mm}^3$$

$$I_t = 415,7 \cdot 10^3 \text{ mm}^4$$

$$I_w = 3285 \cdot 10^9 \text{ mm}^4$$

(1):

$$\frac{N_{Ed}}{\chi_y \cdot N_{Rd}} \leq 1$$

(2):

$$\frac{N_{Ed}}{\chi_z \cdot N_{Rd}} \leq 1$$

Simple resistance:

$$N_{Rd} = A \cdot f_y / \gamma_{M0} = 2727,7 \text{ kN}$$

9.7.2.3. Buckling coefficients

Buckling coefficient in y-direction:

$$L_{cr,y} = 1,0 \cdot L = 12,0 \text{ m}$$

$$\lambda_1 = \pi \cdot \sqrt{\frac{E}{f_y}} = \pi \cdot \sqrt{\frac{210000}{355}} = 76,41$$



$$\lambda_y = \frac{L_{cr,y}}{i_y} = 119,4$$

$$\bar{\lambda}_y = \frac{\lambda_y}{\lambda_1} = 1,562$$

$\alpha = 0,34$ — buckling curve B for I-shape rolled profile $h/b \leq 1,2$, $t \leq 100$ mm – buckling on y-direction

$$\phi = 0,5 \cdot [1 + \alpha(\bar{\lambda} - 0,2) + \bar{\lambda}^2] = 1,952$$

$$\chi_y = \frac{1}{\phi + \sqrt{\phi^2 - \bar{\lambda}^2}} = 0,32$$

Buckling coefficient in z-direction:

$$L_{cr,z} = 1,0 \cdot 6,208 = 6,208 \text{ m}$$

$$\lambda_z = \frac{L_{cr,z}}{i_z} = 103,4$$

$$\bar{\lambda}_z = \frac{\lambda_z}{\lambda_1} = 1,353$$

$\alpha = 0,49$ — buckling curve C for I-shape rolled profile $h/b \leq 1,2$, $t \leq 100$ mm – buckling on z-direction

$$\phi_z = 0,5 \cdot [1 + \alpha(\bar{\lambda} - 0,2) + \bar{\lambda}_z^2] = 1,699$$

$$\chi_z = \frac{1}{\phi + \sqrt{\phi^2 - \bar{\lambda}^2}} = 0,367$$

9.7.2.4. Verification

$$\frac{N_{Ed}}{\chi_y \cdot N_{Rd}} = \frac{770,015 \cdot 10^3}{0,320 \cdot 2727,66 \cdot 10^3 / 1} = \mathbf{0,882} \leq \mathbf{1}$$

$$\frac{N_{Ed}}{\chi_z \cdot N_{Rd}} = \frac{770,015 \cdot 10^3}{0,367 \cdot 2727,66 \cdot 10^3 / 1} = \mathbf{0,769} \leq \mathbf{1}$$

HEA 240 is OK for inner columns



10. Roof bracing

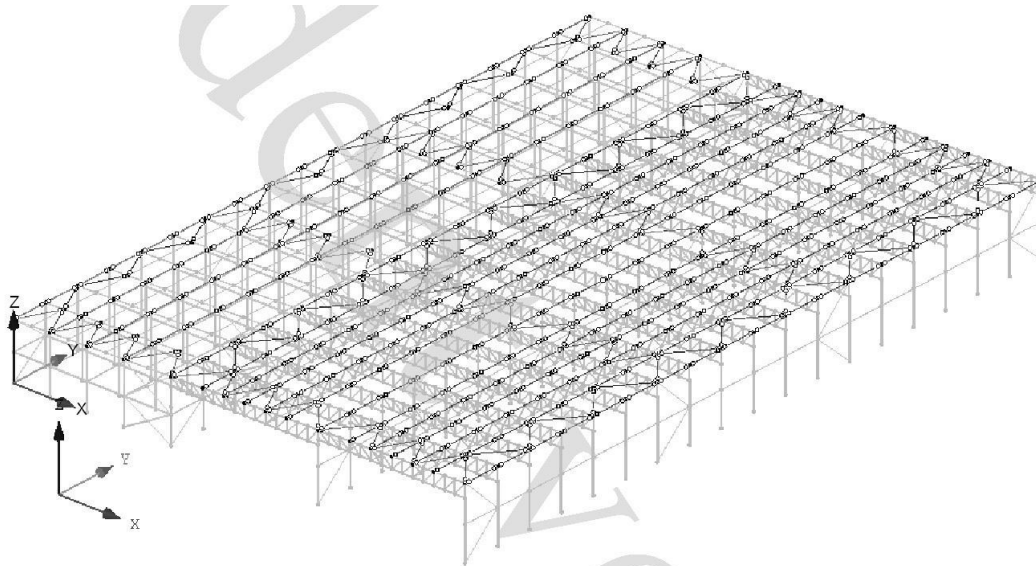

Figure 9.7-1 3D model of roof bracing

In the roof are four transversal bracing, two for each of the edges and two in the middle. The maximum distance between bracing is 35 m. The bracing transfers the load from wind friction to the roof surface and imperfections.

10.1. Internal forces

The design of the bracing will consider the Imperfection for analysis of bracing systems (see 9.3 Imperfection for analysis of bracing systems). Members with the highest compressive and tensile force were selected in each length:

Member No.	Length L [m]	Max. force N+ [kN]	CO	Max. force N- [kN]	CO
3226	7,000	7,817	CO 3	-57,081	CO 1
2211	7,000	63,458	CO 1	-7,426	CO 3
3596	7,827	50,053	CO 8	-23,761	CO 3
3592	7,827	50,911	CO 8	-22,129	CO 3
363	8,063	2,737	CO 3	-89,482	CO 2
628	8,063	30,099	CO 2	-13,001	CO 4
3542	8,323	10,214	CO 4	-32,782	CO 2
3543	8,323	27,549	CO 2	-16,166	CO 4
167	9,221	47,105	CO 3	-135,131	CO 8
172	9,221	53,49	CO 4	-83,122	CO 2

Figure 10.1-1 Internal forces in the roof bracing system



10.2. Bracing profile design

Only square cold-formed hollow-section of steel grade S355 will be used for bracing members. For all tensile and compressive forces in bracing, the following calculation procedure will be used. The results and values will be summarized in the table (Table 10.2-1 Design of roof bracing members).

$$f_y = 355 \text{ MPa}$$

$$E = 210 \text{ GPa}$$

$$N_{t,Rd} = A \cdot \frac{f_y}{\gamma_{M1}}$$

$$L_{cr} = 1,0 \cdot L$$

$$\lambda_1 = \pi \cdot \sqrt{\frac{E}{f_y}} = \pi \cdot \sqrt{\frac{210000}{355}} = 76,41$$

$$\lambda = \frac{L_{cr}}{i}$$

Due to the fact that all members are considered to be slenderness ($\lambda > 200$), the bending moment from the self-weight must be include into verification.

$$\lambda_{rel} = \frac{\lambda}{\lambda_1}$$

$$\phi = 0,5 \cdot [1 + \alpha(\bar{\lambda} - 0,2) + \bar{\lambda}^2]$$

$$\alpha = 0,49 \text{ — buckling curve C for cold formed hollow-section}$$

$$\chi = \frac{1}{\phi + \sqrt{\phi^2 - \bar{\lambda}^2}}$$

$$M_{Ed} = \frac{1}{8} \cdot g_{self-weigh} \cdot l^2$$

$$\psi = 0$$

$$\alpha_h = 0$$

$$C_{my} = 0,95 + 0,05\alpha_h = 0,95$$

$$k_{yy} = C_{my} \left(1 + (\bar{\lambda}_y - 0,2) \frac{N_{Ed}}{\chi_y \cdot N_{Rk} / \gamma_{M1}} \right)$$



$$k_{yy} \leq C_{my} \left(1 + 0,8 \frac{N_{Ed}}{\chi_y \cdot N_{Rk} / \gamma_{M1}} \right)$$

Verification:

$$\frac{N_{t,Ed}}{\chi \cdot A \cdot f_y / \gamma_{M1}} + k_{yy} \frac{M_{Ed}}{W_{y,pl} \cdot f_y / \gamma_{M1}} \leq 1$$

OR:

$$\frac{N_{b,Ed}}{A \cdot f_y / \gamma_{M1}} \leq 1$$



Member No.	Length L [m]	$N_{t,ed}$ [kN]	$N_{b,ed}$ [kN]	M_{Ed} [kNm]	Profile	A [mm ²]	$N_{t,Rd}$ [kN]	$W_{y,pl}$ [mm ³]	M_{Rd} [kNm]	λ [-]	λ_{rel} [-]	χ_y [-]	k_{yy} [-]	$N_{b,Rd}$ [kN]	
3226	7,000	7,82	-57,08	1,07	80x8	2240	795,2	57000	20,2	240,5	3,148	0,087	1,577	69,2	0,909 OK
2211	7,000	63,46	-7,43	1,07	80x8	2240	795,2	57000	20,2	240,5	3,148	0,087	1,0316	69,2	0,162 OK
3596	7,827	50,05	-23,76	0,77	70x5	1270	450,9	100000	35,5	296,5	3,880	0,059	1,6298	26,6	0,930 OK
3592	7,827	50,91	-22,13	0,77	70x5	1270	450,9	100000	35,5	296,5	3,880	0,059	1,5831	26,6	0,867 OK
363	8,063	2,74	-89,48	1,45	120x5	2270	805,9	56000	19,9	172,3	2,255	0,159	1,4801	128	0,805 OK
628	8,063	30,10	-13,00	1,45	120x5	2270	805,9	56000	19,9	172,3	2,255	0,159	1,027	128	0,176 OK
3542	8,323	10,21	-32,78	1,18	80x6	1740	617,7	73300	26	277,4	3,631	0,067	1,5544	41,2	0,866 OK
3543	8,323	27,55	-16,17	1,18	80x6	1740	617,7	73300	26	277,4	3,631	0,067	1,248	41,2	0,449 OK
167	9,221	47,11	-135,13	2,4	150x5	2870	1019	44300	15,7	156,3	2,045	0,189	1,4841	192	0,929 OK
172	9,221	53,49	-83,12	2,4	150x5	2870	1019	44300	15,7	156,3	2,045	0,189	1,2785	192	0,628 OK

Table 10.2-1 Design of roof bracing members



11. Vertical roof bracing

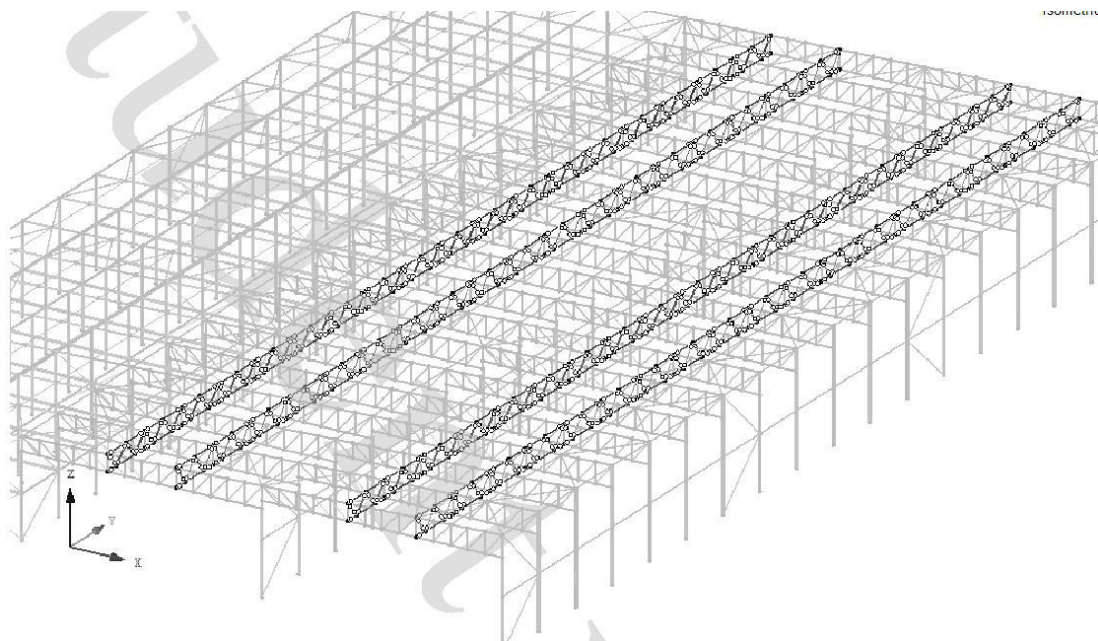

Figure 10.2-1 3D model of vertical bracing

11.1. Internal forces

Members with the highest compressive and tensile force were selected in each length:

Member No.	Length L [m]	Max. force N+ [kN]	CO	Max. force N- [kN]	CO
475	2,485	0	0	-8,358	CO 1
488	7	55,311	CO 2	-5,640	CO 3
912	2,485	10,576	CO 1	0,000	0,000
509	2,485	10,351	CO 1	0,000	0,000
959	2,485	0	0	-8,759	CO 1
1869	7	1,397	CO 3	-19,127	CO 1

Table 11.1-1 Internal forces in the vertical bracing

11.2. Bracing profile design

Only square cold-formed hollow-section of steel grade S355 will be used for bracing members. For all tensile and compressive forces in bracing, the following calculation procedure will be used. The results and values will be summarized in the table (Table 10.2-1 Design of roof bracing members)



$$f_y = 355 \text{ MPa}$$

$$E = 210 \text{ GPa}$$

$$N_{t,Rd} = A \cdot \frac{f_y}{\gamma_{M1}}$$

$$L_{cr} = 1,0 \cdot L$$

$$\lambda_1 = \pi \cdot \sqrt{\frac{E}{f_y}} = \pi \cdot \sqrt{\frac{210000}{355}} = 76,41$$

$$\lambda = \frac{L_{cr}}{i}$$

For slenderness members ($\lambda > 200$), the bending moment from the self-weight must be include into verification.

$$M_{Ed} = \frac{1}{8} \cdot g_{self-weight} \cdot l^2$$

$$\lambda_{rel} = \frac{\lambda}{\lambda_1}$$

$$\phi = 0,5 \cdot [1 + \alpha(\bar{\lambda} - 0,2) + \bar{\lambda}^2]$$

$$\alpha = 0,49 \text{ — buckling curve C for cold formed hollow-section}$$

$$\chi = \frac{1}{\phi + \sqrt{\phi^2 - \bar{\lambda}^2}}$$

$$N_{b,Rd} = \chi \cdot A \cdot \frac{f_y}{\gamma_{M1}}$$

Verification:

$$\frac{N_{Ed}}{\chi \cdot A \cdot f_y / \gamma_{M1}} + \frac{M_{Ed}}{W_{y,pl} \cdot f_y / \gamma_{M1}} \leq 1$$

Member	length	N _{t,Ed}	N _{b,Ed}	M _{Ed}	Profile	A	N _{t,Rd}	W _{y,pl}	M _{Rd}	λ	λ _{rel}	χ	N _{b,Rd}		
No.	L [m]	[kN]	[kN]	[kNm]	SHS	[mm ²]	[kN]	[mm ³]	[kNm]	[-]	[-]	[-]	[kN]		
912	2,485	10,58	0,00	0	40x4	559	198,4	228·10 ³	0	189,9	2,486	0,134	26,5597	0,053	OK
959	2,485	0,00	-8,76	0	40x4	559	198,4	228·10 ³	0	189,9	2,486	0,134	26,5597	0,330	OK
1869	7,000	1,40	-19,13	0,4992	70x4	1040	369,2	1230·10 ³	43,67	261,2	3,418	0,075	27,5745	0,705	OK
488	7,000	55,31	-5,64	0,4992	70x4	1040	369,2	1230·10 ³	43,67	261,2	3,418	0,075	27,5745	0,216	OK

Table 11.2-1 internal forces in vertical bracing



12. Wall bracing

12.1. Internal forces

Members with the highest compressive and tensile force were selected in each length:

Member No.	Length L [m]	Max.force N+ [kN]	CO	Max.force N- [kN]	CO
3484	5,148	75,472	CO 3	-139,579	CO 8
3483	5,148	132,902	CO 4	-83,737	CO 6
3479	5,254	117,392	CO 4	-76,921	CO 6
3478	5,328	78,786	CO 3	-160,617	CO 8
1636	5,328	78,786	CO 3	-160,572	CO 8
3485	5,497	115,86	CO 4	-78,904	CO 6
3482	5,575	80,298	CO 3	-158,658	CO 8
1648	5,575	80,298	CO 3	-158,613	CO 8
2194	7,000	0		-31,370	CO1
3557	8,602	3,692	CO 3	-48,222	CO 2
1647	8,602	20,323	CO 2	-16,31	CO 7
3553	8,613	0,712	CO 3	-41,193	CO 2
446	8,613	37,867	CO 2	-2,735	CO 4
3506	9,086	64,846	CO 2	-6,268	CO 3
3555	9,356	6,369	CO 3	-83,038	CO 2
3507	9,356	6,643	CO 3	-71,244	CO 2

Table 12.1-1 Internal forces in the wall bracings

12.2. Bracing profile design

Only square cold-formed hollow-section of steel grade S355 will be used for bracing members. For all tensile and compressive forces in bracing, the following calculation procedure will be used. The results and values will be summarized in the table (Table 10.2-1 Design of roof bracing members)

$$f_y = 355 \text{ MPa}$$

$$E = 210 \text{ GPa}$$

$$N_{t,Rd} = A \cdot \frac{f_y}{\gamma_{M1}}$$

$$L_{cr} = 1,0 \cdot L$$



$$\lambda_1 = \pi \cdot \sqrt{\frac{E}{f_y}} = \pi \cdot \sqrt{\frac{210000}{355}} = 76,41$$

$$\lambda = \frac{L_{cr}}{i}$$

For slenderness members ($\lambda > 200$), the bending moment from the self-weight must be include into verification:

$$M_{Ed} = \frac{1}{8} \cdot g_{self-weight} \cdot l^2$$

$$\lambda_{rel} = \frac{\lambda}{\lambda_1}$$

$$\phi = 0,5 \cdot [1 + \alpha(\bar{\lambda} - 0,2) + \bar{\lambda}^2]$$

$$\alpha = 0,49 \text{ — buckling curve C for cold formed hollow-section}$$

$$\chi = \frac{1}{\phi + \sqrt{\phi^2 - \bar{\lambda}^2}}$$

$$N_{b,Rd} = \chi \cdot A \cdot \frac{f_y}{\gamma_{M1}}$$

Verification:

$$\frac{N_{Ed}}{\chi \cdot A \cdot f_y / \gamma_{M1}} + \frac{M_{Ed}}{W_{y,pl} \cdot f_y / \gamma_{M1}} \leq 1$$



Member No.	length L [m]	Nt,ed [kN]	Nb,ed [kN]	Med [kNm]	Profile SHS	A [mm ²]	Nt,Rd [kN]	Wy,pl [mm ³]	MRd [kNm]	λ [-]	λ_{rel} [-]	χ [-]	Nb,Rd [kN]	
3484	5,148	75,47	-139,58	0	100x5	1870	663,9	68000	0	133,4	1,745	0,247	163,837	0,852 OK
3483	5,148	132,90	-83,74	0	100x5	1870	663,9	68000	0	133,4	1,745	0,247	163,837	0,511 OK
3479	5,254	117,39	-76,92	0	80x6	1740	617,7	73300	0	175,1	2,292	0,155	95,5306	0,805 OK
3478	5,328	78,79	-160,62	0	100x6	2220	788,1	57500	0	139,5	1,825	0,229	180,547	0,890 OK
1636	5,328	78,79	-160,57	0	100x6	2220	788,1	57500	0	139,5	1,825	0,229	180,547	0,889 OK
3485	5,497	115,86	-78,90	0	80x6	1740	617,7	73300	0	183,2	2,398	0,143	88,1563	0,895 OK
3482	5,575	80,30	-158,66	0	100x6	2220	788,1	57500	0	145,9	1,910	0,212	167,264	0,949 OK
1648	5,575	80,30	-158,61	0	100x6	2220	788,1	57500	0	145,9	1,910	0,212	167,264	0,948 OK
2194	7	0	-31,37	0	70x6	1500	532,5	85100	0	270,3	3,537	0,070	37,3	0,841 OK
3557	8,602	3,69	-48,22	1,3596	100x5	1870	663,9	68000	24,14	222,8	2,916	0,100	66,4834	0,782 OK
1647	8,602	20,32	-16,31	1,3596	100x5	1870	663,9	68000	24,14	222,8	2,916	0,100	66,4834	0,302 OK
3553	8,613	0,71	-41,19	1,3631	100x5	1870	663,9	68000	24,14	223,1	2,920	0,100	66,3279	0,678 OK
446	8,613	37,87	-2,74	1,3631	100x5	1870	663,9	68000	24,14	223,1	2,920	0,100	66,3279	0,098 OK
3506	9,086	64,85	-6,27	1,517	100x5	1870	663,9	68000	24,14	235,4	3,081	0,091	60,1197	0,167 OK
3555	9,356	6,37	-83,04	1,9476	120x5	2270	805,9	56000	19,88	199,9	2,616	0,122	98,3484	0,942 OK
3507	9,356	6,64	-71,24	1,9476	120x5	2270	805,9	56000	19,88	199,9	2,616	0,122	98,3484	0,822 OK

Table 12.2-1 Wall bracing profile design

13. Design of administrative part

13.1. Floor construction

Floor construction is designed as composite steel deck floor as continuous slab.

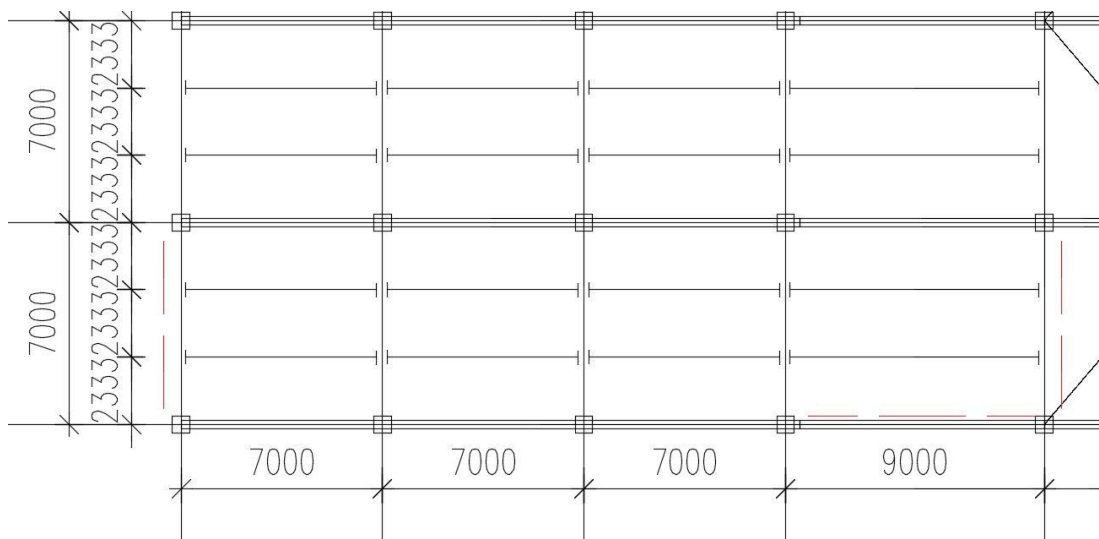

Table 13.1-1 Sketch of the floor construction



13.1.1. Loads

a) Mounting stage load

Permanent load	kN/m ²		kN/m ²
Concrete slab (26 kN/m ³ ·0,1129m)	2,935	1,35	3,96
Trapezoidal sheet	0,105	1,35	0,14
	3,040		4,10

Table 13.1-2 Permanent load on the trapezoidal sheet

Imposed load	kN/m ²		kN/m ²
Increased mounting load on the 3x3m area	1,5	1,5	2,25

Table 13.1-3 Imposed load on the trapezoidal sheet

b) Composite stage load (in service)

Permanent load	kN/m ²		kN/m ²
Floor system 60mm	1,200	1,35	1,62
Concrete slab (25 kN/m ³)	2,822	1,35	3,81
Trapezoidal sheet	0,105	1,35	0,14
Ceiling system	0,150	1,35	0,20
	4,277		5,77

Table 13.1-4 Permanent load on the floor construction

Imposed load	kN/m ²		kN/m ²
Live load	1,5	1,5	2,25
Partition walls	0,5	1,5	0,75
	2		3,00

Table 13.1-5 Imposed loads on the floor structures



13.1.2. Trapezoidal sheets

The trapezoidal sheet is designed as a continuous beam with three load transfer fields at the mounting stage, as shown in the Figure 13.1-1:

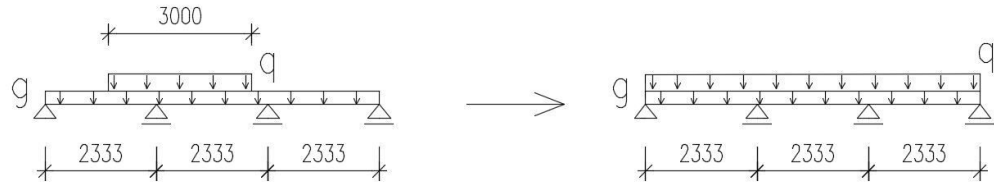

Figure 13.1-1 Sketch of the load on the floor

$d = 150 \text{ mm}$ — thickness of the floor construction (concrete slab + trapezoidal sheet)

$d_c = 150 - 37,1 = 112,9 \text{ mm}$ — average depth of the concrete

$g_k + q_k = 3,040 + 1,5 = 4,54 \text{ kN/m}^2$

$g_d + q_d = 4,10 + 2,25 = 6,35 \text{ kN/m}^2$

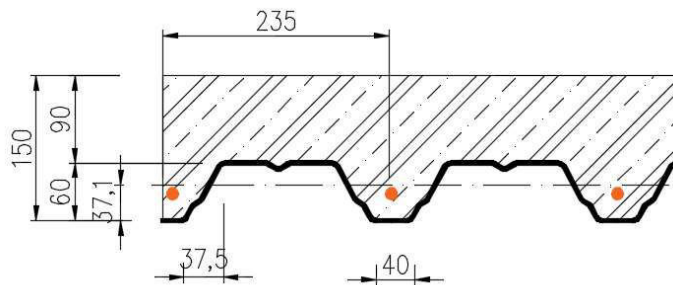

Figure 13.1-2 Slab cross-section

Preliminary estimate of trapezoidal sheet: **TR60/235/1,0**

Steel S320GD

$h = 60 \text{ mm}$

$m = 10,51 \text{ kg}$

$W_{y,eff} = 17360 \text{ mm}^3$

$I_{y,eff} = 627000 \text{ mm}^4$

$q_{Ed} = 9,28 \text{ kN/m}^2 > 6,35 \text{ kN/m}^2 = (g + q)_d$

ULS is OK



$$M_{b,k} = -\frac{1}{10} \cdot g_k L^2 = -\frac{1}{10} \cdot 3,040 \cdot 2,222^2 = -1,655 \text{ kN/m}^2$$

$$\delta = \frac{1}{E \cdot I_{eff}} \left(\frac{5}{384} \cdot g_k L^4 + \frac{1}{16} M_{b,k} L^2 \right) = 8,902 \text{ mm} < \frac{t_{slab}}{10} = 11,3 \text{ mm}$$

NO PONDING EFFECT

13.1.3. Preliminary design of concrete slab

$t = 150 \text{ mm}$ — thickness of the ceiling structure

$t_{slab} = 113 \text{ mm}$ — average depth of the concrete

$$(g + q)_d = 4,10 + 5,77 = 9,88 \text{ kN/m}^2$$

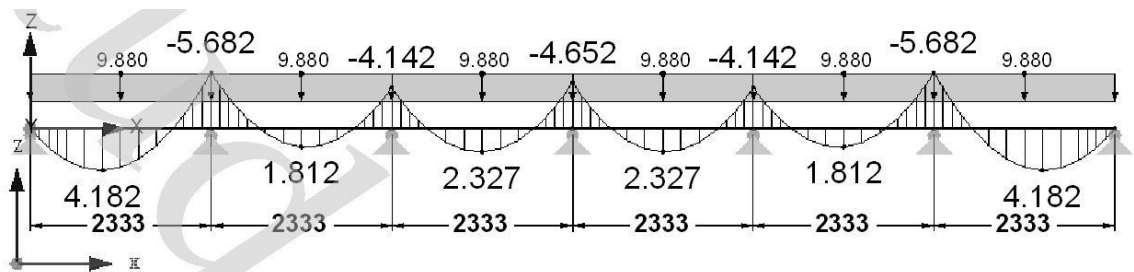

Figure 13.1-3 Bending moments on the concrete slab

$M_{Ed+} = 4,182 \text{ kNm}$ — max. bending moment on the field

$M_{Ed-} = 5,862 \text{ kNm}$ — max. bending moment under support

$c = 20 \text{ mm}$ — nominal cover to reinforcement in deck

Verification bending resistance of concrete slab:

$$F_c = F_s$$

$$F_s = A_s \cdot f_{yd}$$

$$F_c = \lambda \cdot x \cdot b \cdot f_{cd}$$

$$M_{Rd} = F_s \cdot r = F_c \cdot r$$

a) Lower fibers (positive bending moment)

Try 12 mm dia. reinforcement, one piece in each trapezoidal sheet rib ($n=4,3 \text{ piece/m}'$):

$$\phi = 12 \text{ mm}$$

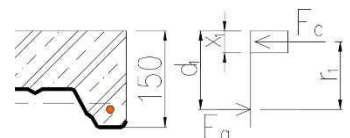



$A_s = n \cdot \pi \cdot r^2 = 4,3 \cdot \pi \cdot 12^2 / 4 = 456,3 \text{ mm}^2$ — *area of steel is greater than required minimum area of steel and less than required maximum area of steel*

$$d = 150 - 20 - \frac{12}{2} = 124 \text{ mm}$$

$$x = \frac{A_s \cdot f_{yd}}{0,8 \cdot b \cdot f_{cd}} = \frac{456,3 \cdot 435}{0,8 \cdot 1000 \cdot 20} = 13,2 \text{ mm}$$

$$r = d - 0,4x = 124 - 0,4 \cdot 13,2 = 118,7 \text{ mm}$$

$$M_{Rd} = 456,3 \cdot 435 \cdot 118,7 = 25,1 \text{ kNm} > 4,182 \text{ kNm} = M_{Ed}$$

b) Upper fibers (negative bending moment)

$$\phi = 12 \text{ mm}$$

$A_s = n \cdot \pi \cdot r^2 = 5 \cdot \pi \cdot 12^2 / 4 = 565,5 \text{ mm}^2$ — *area of steel is greater than required minimum area of steel and less than required maximum area of steel*

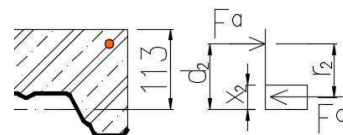

$$d = 150 - 20 - \frac{12}{2} = 124 \text{ mm}$$

$$x = \frac{A_s \cdot f_{yd}}{0,8 \cdot b \cdot f_{cd}} = \frac{565,5 \cdot 435}{0,8 \cdot 1000 \cdot 20} = 15,4 \text{ mm}$$

$$r = d - 0,4x = 124 - 0,4 \cdot 15,4 = 117,9 \text{ mm}$$

$$M_{Rd} = 565,5 \cdot 435 \cdot 117,9 = 29,0 \text{ kNm} > 5,682 \text{ kNm} = M_{Ed}$$

Designed reinforcement satisfy design principles for reinforced concrete elements.

ϕ 8mm à 235 mm for bottom surface and ϕ 8mm à 200 mm for upper surface

13.1.4. Secondary beam (9m span)

13.1.4.1. Mounting stage

$l = 9 \text{ m}$ — *length of the longest joist*

$B = 2,333 \text{ mm}$ — *loading width*

Loads:

Permanent load	kN/m		kN/m
Concrete slab	6,849	1,35	9,25
Trapezoidal sheet	0,245	1,35	0,33

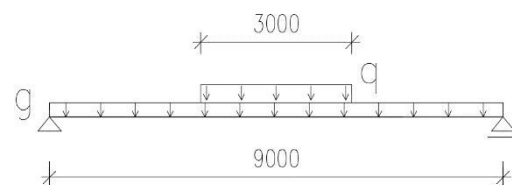

Figure 13.1-4 Static load scheme at the mounting stage



Secondary beam 's self-weight	0,4	1,35	0,54
	7,494		10,12

Table 13.1-6 Permanent load

Imposed load may be considered as mounting load during concreting (continuous load along its entire length) or increased mounting load on the area 3x3m:

Imposed load	kN/m	kN/m	kN/m
Mounting load	1,75	1,5	2,625
increased load 3x3m	3,5	1,5	5,25

Table 13.1-7 Imposed load

Permanent load + continuous mounting load:

$$R_{Ed} = V_{Ed} = \frac{(10,12 + 2,625) \cdot 9}{2} = 57,338 \text{ kN}$$

$$M_{Ed} = 57,338 \cdot \frac{9}{2} - (10,12 + 2,625) \cdot \frac{4,5^2}{2} = 129,01 \text{ kNm}$$

Permanent load + increased load on the area 3x3m:

$$R_{Ed} = V_{Ed} = \frac{10,12 \cdot 9 + 5,25 \cdot 3}{2} = 53,4 \text{ kN}$$

$$M_{Ed} = 53,4 \cdot \frac{9}{2} - 10,12 \cdot \frac{4,5^2}{2} - 5,25 \cdot \frac{1,5^2}{2} = 134,92 \text{ kNm}$$

$$W_{min} = \frac{M_{Ed,max}}{f_{yd}} = \frac{134,92 \cdot 10^6}{355} = 380,05 \cdot 10^3 \text{ mm}^3$$

→ IPE 270 (S355)

$$m = 36,10 \text{ kg/m} = 0,36 \text{ kN/m} < 0,4 \text{ kN/m}$$

$$A = 4595 \text{ mm}^2$$

$$W_{pl,y} = 484,0 \cdot 10^3 \text{ mm}^3$$

$$I_y = 57,898 \cdot 10^6 \text{ mm}^4$$

$$A_{vz} = 2214 \text{ mm}^2$$

ULS:

$$\begin{aligned} M_{pl,Rd} &= W_{pl,y} \cdot f_{yd} = 484,0 \cdot 10^3 \cdot 355 = 171,819 \text{ kNm} > 134,92 \text{ kNm} \\ &= M_{Ed} \end{aligned}$$



$$V_{pl,Rd} = A_{vz} \cdot f_{yd} / \sqrt{3} = 2214 \cdot 355 / \sqrt{3} = 453,780 \text{ kN} \gg 57,338 \text{ kN}$$

$$= V_{Ed}$$

$$\delta = \frac{5}{384} \cdot \frac{g_k L^4}{E \cdot I_{eff}} = \frac{5}{384} \cdot \frac{7,494 \cdot 9000^4}{210000 \cdot 57,898 \cdot 10^6} = 52,65 \text{ mm} > \frac{t_{slab}}{10}$$

$$= 15 \text{ mm}$$

Since the deflection is greater than 1/10 of the thickness of the concrete slab, the pounding effect (load increase) must be included.

$$\delta_0 = 0,7 \cdot \delta = 36,9 \text{ mm}$$

$$\Delta q_k = \delta_0 \cdot B \cdot 26 = 0,0369 \cdot 2,333 \cdot 26 = 2,236 \text{ kN/m}$$

$$\Delta q_d = 1,35 \cdot \Delta q_k = 1,35 \cdot 2,239 = 3,02 \text{ kN/m}$$

$$M_{Ed}' = 134,92 + \frac{1}{8} \cdot 3,02 \cdot 9^2 = 165,481 \text{ kNm}$$

$$M_{pl,Rd} = 171,819 \text{ kNm} > 165,481 \text{ kNm} = M_{Ed}'$$

IPE 270 is OK

13.1.4.2. Composite stage (in service)

Concrete C30/37

$$f_{ck} = 30 \text{ MPa}$$

$$f_{cd} = 0,8 \cdot \frac{30}{1,5} = 16 \text{ MPa}$$

$$E_{cm} = 33 \text{ GPa}$$

Loads:

Permanent load	kN/m	
Floor system 60mm	2,800	1,35
Concrete slab (25 kN/m ³)	6,585	1,35
Trapezoidal sheet	0,245	1,35
Ceiling system	0,350	1,35
Pounding effect	2,236	1,35
IPE300	0,361	1,35
	12,577	16,979

Imposed load	kN/m	
Live load	3,500	1,5



Partitions walls	1,167	1,5	1,75
	4,667		7,00

Internal forces:

$$M_{Ed} = \frac{1}{8} \cdot (16,979 + 7,0) \cdot 9^2 = 242,8 \text{ kNm}$$

$$V_{Ed} = \frac{1}{2} \cdot (16,979 + 7,0) \cdot 9 = 107,91 \text{ kN}$$

Verification:

$$b_{eff} = 2 \cdot b_{e1} = L/4 = 9000/4 = 2250 \text{ mm} \text{ — effective board width}$$

$$b_{eff} < B = 9000 \text{ mm}$$

Precondition: The neutral axis lies in the concrete slab.

$$N_a = N_c$$

$$N_a = A_a \cdot f_{yd}$$

$$N_c = x \cdot b_{eff} \cdot f_{cd}$$

$$x = \frac{A_a \cdot f_{yd}}{b_{eff} \cdot f_{cd}} = \frac{4595 \cdot 355}{2250 \cdot 17} = 45,31 \text{ mm} < 112,9 \text{ mm} = d_c$$

OK

$$r = \frac{270}{2} + 150 - \frac{45,31}{2} = 262,34 \text{ mm}$$

$$N_a = A_a \cdot f_{yd} = 4595 \cdot 355 = 1631,05 \text{ kN}$$

$$M_{pl,Rd} = N_a \cdot r = 427,9 \text{ kNm} > 242,63 \text{ kNm} = M_{Ed}$$

$$V_{pl,Rd} = A_{vz} \cdot f_{yd} / \sqrt{3} = 2214 \cdot 355 / \sqrt{3} = 453,780 \text{ kN} \gg 107,91 \text{ kN}$$

$$= V_{Ed}$$

ULS is OK

13.1.4.3. Shear studs design

Welded Shear Studs:

$$d = 25 \text{ mm}$$

$$h_{sc} = 100 \text{ mm}$$

$$f_{yd} = 355 \text{ MPa}$$

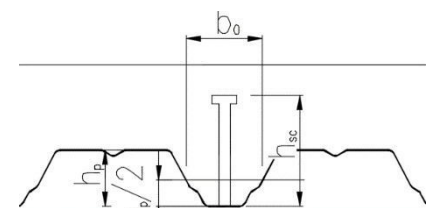

Figure 13.1-6 Scheme of the studs geometry



$$f_u = 490 \text{ MPa}$$

The design shear resistance of a single shear connector in a solid slab is the smaller of:

$$P_{Rd,1} = 0,8 \cdot f_u \cdot \left(\pi \cdot \frac{d^2}{4} \right) \cdot \frac{1}{\gamma_v} = 0,8 \cdot 490 \cdot \left(\pi \cdot \frac{25^2}{4} \right) = 153,94 \text{ kN}$$

$$P_{Rd,2} = 0,29 \cdot \alpha \cdot d^2 \cdot \frac{\sqrt{f_{ck} \cdot E_{cm}}}{\gamma_v} = 0,29 \cdot 1 \cdot 25^2 \cdot \frac{\sqrt{490 \cdot 33000}}{1,25} = 144,3 \text{ kN}$$

Where:

$$\alpha = 0,2 \left(\frac{h_{sc}}{d} + 1 \right) = 0,2 \cdot \left(\frac{100}{25} + 1 \right) = 1$$

Reduction factor for the studs in the ribbed slab:

$$k_t = \frac{0,7}{\sqrt{n_s}} \cdot \frac{b_0}{h_p} \left(\frac{h_{sc}}{h_p} - 1 \right) = \frac{0,7}{\sqrt{1}} \cdot \frac{81}{60} \left(\frac{100}{60} - 1 \right) = 0,63$$

Where:

$$n_s = 1 \text{ — number of studs in a rib}$$

$$b_0 \text{ — is evident from the Figure 13.1-6}$$

Load capacity of one stud:

$$P_{Rd} = k_t \cdot \min(P_{Rd,1}; P_{Rd,2}) \cdot 0,63 \cdot 144,3 = 90,89 \text{ kN}$$

$$F_{ct} = N_c = N_a = 1631,1 \text{ kN}$$

Degree of shear connection:

$$n_f = F_{ct}/P_{Rd} = 1631,1/90,89 = 17,94 \cong 18 \text{ — required number of the studs on the half of the secondary beam for total resistance.}$$

$$n_{f,max} = 9000/235/2 = 38,30/2 \cong 19 \text{ — max. possible number of the studs on the half of the secondary beam (in the case of one studs in every rib).}$$

Shear stud SD 25/100 is designed in each rib



13.1.4.4. Serviceability limit state

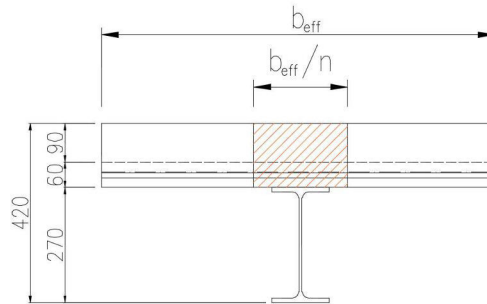

$$M_{Ek,m} = 1/8 \cdot 7,494 \cdot 9000^2 = 75,846 \text{ kNm} \text{ — bending moment from permanent load in mounting stage}$$

$$M_{Ek,s} = 1/8 \cdot (12,577 + 4,667 - 7,494) \cdot 9000^2 = 98,72 \text{ kNm} \text{ — bending moment from other permanent and imposed loads in service stage}$$

$$E'_c = \frac{E_{cm}}{2} = \frac{33000}{2} = 16500 \text{ MPa}$$

$$n = 210/16,5 = 12,727 \text{ — ratio of steel and concrete elastic module}$$

$$A_i = 5381 + 113 \cdot 1750/12,727 = 20505 \text{ mm}^2$$

$$e = z_d = \frac{(5381 \cdot 270/2 + 90 \cdot 2250/12,727 \cdot (270 + 60 + 90/2))}{17756,2} = 321 \text{ mm}$$

$$I_i = 57,9 \cdot 10^6 + 4595 \cdot \left(321 - \frac{300}{2}\right)^2 + \frac{1}{12,727} \cdot (1750 \cdot 90^3/12) + 1750 \cdot 90 \cdot (321 - 270 - 60 - 90)^2 = 274,0 \cdot 10^6 \text{ mm}^4$$

$$\sigma_{a,max} = \frac{M_{Ek,m}}{W_y} + \frac{M_{Ek,s}}{I_i} \cdot z_d = \frac{75,846 \cdot 10^6}{484,0 \cdot 10^3} + \frac{98,72}{274,0} \cdot 321 = 272,51 \text{ MPa} < 355 \text{ MPa} = f_{yd}$$

OK

$$\sigma_{c,max} = \frac{M_{Ek}}{n \cdot I_i} \cdot z_h = \frac{98,72}{12,727 \cdot 274,0} \cdot (270 + 150 - 321) = 2,8 \text{ MPa} < 16 \text{ MPa} = f_{cd}$$

OK



Deflection (from variable loads only):

$$\delta_2 = \frac{5}{384} \cdot \frac{q_p \cdot L^4}{E \cdot I_i} = \frac{5}{384} \cdot \frac{4,667 \cdot 9000^4}{210000 \cdot 274,0 \cdot 10^6} = 6,93 \text{ mm} < \frac{9000}{250}$$

$$= 36 \text{ mm} = \delta_{lim}$$

OK

IPE270 satisfied for secondary beam 9 m span

13.1.5. Secondary beam (7m span)

The other beams (span 7 m) will be designed in the same way as 13.1.4 Secondary beam (9m span) the results are shown in the following chapters. Try IPE 220 (S355):

L=	7	m	Length of the secondary beam
	IPE 220		designed cross-section
A=	3337	mm ²	area of the cross section
m=	26	kg	weight of the cross section
W _{y,pl} =	285406	mm ³	
I _y =	27718365	mm ⁴	
A _{vz} =	1588	mm ²	

13.1.5.1. Mounting stage

			Reaction: permanent load + continuous mounting load
	R _{Ed1} =	43,284 kN	
	M _{Ed1} =	86,57 kNm	Bending moment: permanent load + continuous mounting load
	R _{Ed2} =	44,596 kN	Reaction: permanent load + continuous mounting load
	M _{Ed2} =	78,04 kNm	Bending moment: permanent load + continuous mounting load
ULS			
Check	M _{pl,Rd} =	101,319 kNm	> 86,57 kNm OK
	V _{pl,Rd} =	325,475 kN	> 44,596 kNm OK
SLS			
Check	δ=	40,249 mm	deflection is greater than 1/10 of the thickness of the concrete slab
	δ ₀ =	28,174 mm	(0,7 · δ)
	Δq _k =	1,709 kN/m	
	Δq _d =	2,307 kN/m	
	M _{Ed} '=	100,708 kNm	< 101,31 kNm OK



13.1.5.2. Composite stage (in service)

	$(g+q)_d =$	23,979	kN/m		
	$M_{Ed} =$	146,87	kNm		
	$R_{Ed} =$	83,93	kN		
	$f_{ck} =$	30,00	MPa		
	$f_{cd} =$	16,000	Mpa		
	$E_{cm} =$	33	Gpa		
	$b_{eff} =$	1,75	m		
	$N_a =$	1184,65	kN		
	$x =$	42,31	mm	<113 mm	OK
	$r =$	238,845	mm		
ULS					
Check	$M_{pl,Rd} =$	282,949	kNm	> 146,87 kNm	OK
	$V_{pl,Rd} =$	325,475	kN	> 83,927 kNm	OK

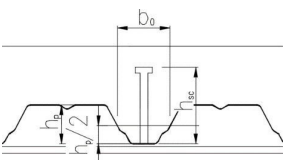

Figure 13.1-7 Scheme of the studs geometry

13.1.5.3. Shear studs design

$d =$	25	mm	
$h_{cs} =$	100	mm	
$n_s =$	1		the number of studs in the one rib
$f_y =$	355	MPa	shear studs yield strength
$f_u =$	490	MPa	shear studs ultimate strength
$P_{Rd,1} =$	119,210	kN	load capacity of one shear stud
$P_{Rd,2} =$	111,725	kN	load capacity of one shear stud
$h_c/d_s =$	4,5		
$\alpha =$	1		
$b_0 =$	81	mm	
$k_t =$	0,63	<0,85	reduction factor of the studs
$P_{Rd} =$	90,892	kN	load capacity of one shear stud
$F_{ct} = N =$	1184,65	kN	
	$n_f =$	27,00	required number of the studs on the half of the secondary beam.
	$n_{max} =$	29,79	max. possible number of the studs

Shear stud SD 25/100 is designed in each rib

13.1.5.4. Serviceability limit state

$(g+q)_k =$	17,244	kN/m
$M_{Ek} =$	105,62	kNm



E_c'	= 16500	Mpa	concrete elastic module	
n	= 12,727		ratio of steel and concrete elastic module	
A_i	= 15712,1	mm ²	area of the ideal cross-section	
e	= 315,013			
I_i	= 173367080	mm ⁴		
$\sigma_{a,max}$	= 191,912	MPa	< 355 Mpa = f_y	OK
$\sigma_{c,max}$	= 5,025	MPa	< 16 Mpa = f_{cd}	OK
δ_2	= 4,01	mm	< 28 mm	OK

OK

IPE220 satisfied for secondary beam 7 m span

13.1.6. Primary beam (inner)

The primary beam is supported in the mounting stage.

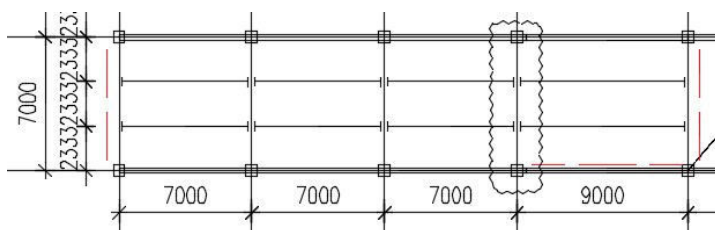

Figure 13.1-9 Position of the primary beam

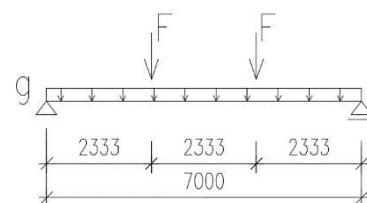

Figure 13.1-8 Static scheme of beam load

$L = 7\text{ m}$ — length of primary beam

Reactions from connected secondary beam:

$$F_{Ek} = (12,577 + 4,667) \cdot \frac{7 + 9}{2} = 137,95\text{ kN}$$

$$F_{Ed} = (16,979 + 7,00) \cdot \frac{7 + 9}{2} = 191,83\text{ kN}$$

Self-weight of primary beam:

$$g_k = 0,5\text{ kN/m}$$

$$g_d = 1,35 \cdot 0,5 = 0,675\text{ kN/m}$$

$$R_{Ek} = (137,95 + 0,5 \cdot 7/2) = 139,70\text{ kN}$$

$$M_{Ek} = 139,7 \cdot \frac{7}{2} - 137,95 \cdot \frac{7}{6} - 0,5 \cdot \frac{7^2}{8} = 324,95\text{ kNm}$$

$$R_{Ed} = (191,83 + 0,675 \cdot 7/2) = 194,28\text{ kN}$$

$$M_{Ed} = 194,28 \cdot \frac{7}{2} - 191,83 \cdot \frac{7}{6} - 0,945 \cdot \frac{7^2}{8} = 451,90\text{ kNm}$$



$$W_{min} = \frac{M_{Ed}}{f_{yd}} = \frac{451,90}{355} = 1273 \cdot 10^3 \text{ mm}^3$$

The profile of the steel beam will be chosen less than that required for M_{Ed} . The whole moment carries by steel-concrete cross section.

IPE 300 (S355) – 1st class cross section for bending

$$A = 5381 \text{ mm}^2$$

$$m = 42 \text{ kg/m} = 0,42 \text{ kN/m} < 0,5 \text{ kN/m} - \text{OK}$$

$$W_{y,pl} = 628,4 \cdot 10^3 \text{ mm}^3$$

$$I_y = 83,56 \cdot 10^6 \text{ mm}^4$$

$$A_{vz} = 2568 \text{ mm}^2$$

Concrete C30/37:

$$f_{ck} = 30 \text{ MPa}$$

$$f_{cd} = 0,8 \cdot \frac{30}{1,5} = 16 \text{ MPa}$$

$$E_{cm} = 33 \text{ GPa}$$

$$b_{eff} = \frac{L}{4} = \frac{7000}{4} = 1,72 \text{ m} < B = (7 + 9)/2 = 8 \text{ m}$$

13.1.6.1. ULS verification

Balance of internal forces:

Precondition: The neutral axis lies in the concrete slab.

$$N_a = N_c$$

$$N_a = A_a \cdot f_{yd}$$

$$N_c = x \cdot b_{eff} \cdot f_{cd}$$

$$x = \frac{A_a \cdot f_{yd}}{b_{eff} \cdot f_{cd}} = \frac{2568 \cdot 355}{1750 \cdot 16} = 68,23 \text{ mm} < 112,9 \text{ mm} = d_c$$

OK

$$r = \frac{300}{2} + 150 - \frac{68,23}{2} = 250,887 \text{ mm}$$

$$N_a = A_a \cdot f_{yd} = 2568 \cdot 355 = 1910,33 \text{ kN}$$

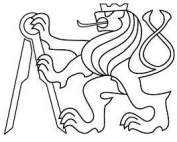

$$M_{pl,Rd} = N_a \cdot r = 479,276 \text{ kNm} > 451,74 \text{ kNm} = M_{Ed}$$

$$V_{pl,Rd} = A_{vz} \cdot f_{yd} / \sqrt{3} = 2568 \cdot 355 / \sqrt{3} = 526,336 \text{ kN} > 194,2 \text{ kN} = V_{Ed}$$

Small shear, there is no need to verify the shear and bend interaction.

ULS is OK

13.1.6.2. Shear studs design

Welded Shear Studs:

$$d = 25 \text{ mm}$$

$$h_{sc} = 100 \text{ mm}$$

$$f_{yd} = 355 \text{ MPa}$$

$$f_u = 490 \text{ MPa}$$

The design shear resistance of a single shear connector in a solid slab is the smaller of:

$$P_{Rd,1} = 0,8 \cdot f_u \cdot \left(\pi \cdot \frac{d^2}{4} \right) \cdot \frac{1}{\gamma_v} = 0,8 \cdot 490 \cdot \left(\pi \cdot \frac{25^2}{4} \right) = 153,94 \text{ kN}$$

$$P_{Rd,2} = 0,29 \cdot \alpha \cdot d^2 \cdot \frac{\sqrt{f_{ck} \cdot E_{cm}}}{\gamma_v} = 0,29 \cdot 1 \cdot 25^2 \cdot \frac{\sqrt{490 \cdot 33000}}{1,25} = 144,3 \text{ kN}$$

Where:

$$\alpha = 0,2 \left(\frac{h_{sc}}{d} + 1 \right) = 0,2 \cdot \left(\frac{100}{25} + 1 \right) = 1$$

Reduction factor for the studs perpendicularly to the ribbed slab:

$$k_t = \frac{0,6}{\sqrt{n_s}} \cdot \frac{b_0}{h_p} \left(\frac{h_{sc}}{h_p} - 1 \right) = \frac{0,7}{\sqrt{1}} \cdot \frac{81}{60} \left(\frac{100}{60} - 1 \right) = 0,54$$

Where:

$$n_s = 1 \text{ — number of studs in a rib}$$

$$b_0 \text{ — is evident from the Figure 13.1-6}$$

Load capacity of one stud:

$$P_{Rd} = k_t \cdot \min(P_{Rd,1}; P_{Rd,2}) \cdot 0,54 \cdot 144,3 = 77,908 \text{ kN}$$

$$F_{ct} = N_c = N_a = 1910,33 \text{ kN}$$



$$n_f = F_{ct}/P_{Rd} = 1910,33 / 77,908 = 50 \text{ — required number of the studs} \\ \text{on the primary beam}$$

$$L/n_f = 140 \text{ mm}$$

Shear stud SD 25/100 is designed every 140 mm

13.1.6.3. Serviceability limit state

$$R_{Ek} = \frac{0,5 \cdot 7 + 2 \cdot 137,95}{2} = 139,7 \text{ kN}$$

$$M_{Ek} = 139,7 \cdot \frac{7}{2} - 137,95 \cdot \frac{7}{6} - 0,5 \cdot 7^2/8 = 324,95 \text{ kNm}$$

$$E'_c = \frac{E_{cm}}{2} = \frac{33000}{2} = 16500 \text{ MPa}$$

$$n = 210/16,5 = 12,727$$

$$A_i = 5381 + 90 \cdot 1750/12,727 = 17756,2 \text{ mm}^2$$

$$e = \frac{(5381 \cdot 300/2 + 90 \cdot 1750/12,727 \cdot (300 + 60 + 90/2))}{17756,2} \\ = 327,7 \text{ mm}$$

$$I_i = 83,6 \cdot 10^6 + 5381 \cdot \left(327,7 - \frac{300}{2}\right)^2 + \frac{1}{12,727} \cdot (1750 \cdot 90^3/12) \\ + 1750 \cdot 90 \cdot (327,7 - 300 - 60 - 90/2)^2 \\ = 335,8 \cdot 10^6 \text{ mm}^4$$

$$\sigma_{a,max} = \frac{M_{Ek}}{I_i} \cdot z_d = \frac{324,95}{335,8} \cdot 327,7 = 317,15 \text{ MPa} < 355 \text{ MPa} = f_{yd}$$

OK

$$\sigma_{c,max} = \frac{M_{Ek}}{n \cdot I_i} \cdot z_h = \frac{324,95}{12,727 \cdot 335,8} \cdot (300 + 150 - 327) = 9,3 \text{ MPa} \\ < 30 \text{ MPa} = f_{cd}$$

OK



Deflection (from variable loads only):

$$\delta_2 = \frac{23}{648} \cdot \frac{F_k \cdot L^3}{E \cdot I_i} = \frac{5}{384} \cdot \frac{4,667 \cdot (7000 + 9000) \cdot 7000^3}{210000 \cdot 335,8 \cdot 10^6} = 12,9 \text{ mm}$$

$$< \frac{7000}{400} = 17,5 \text{ mm} = \delta_{lim}$$

$$\delta_{max} = \frac{23}{648} \cdot \frac{F_k \cdot L^4}{E \cdot I_i}$$

$$= \frac{5}{384}$$

$$\cdot \frac{(4,667 + 12,577 - 7,494) \cdot (7000 + 9000) \cdot 7000^3}{210000 \cdot 335,8 \cdot 10^6}$$

$$= 26,93 \text{ mm} < \frac{7000}{250} = 28 \text{ mm} = \delta_{lim}$$

OK

IPE300 satisfied for primary inner beam

13.1.7. Primary beam (outer)

The primary beam is supported in the mounting stage.

Try IPE 220 (S355):

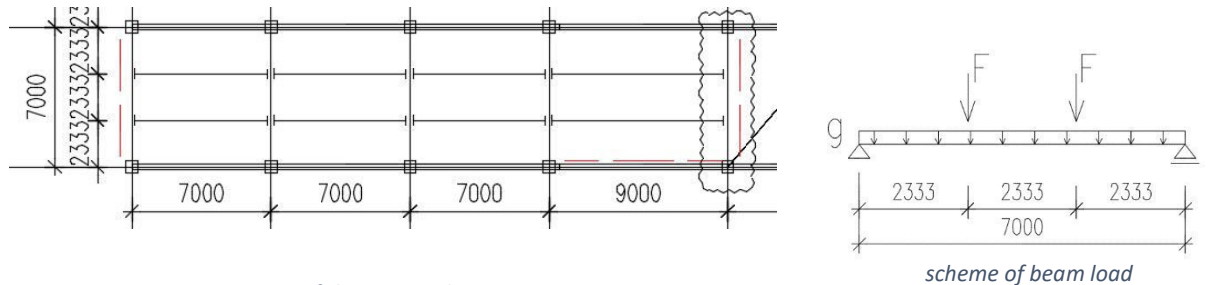

Figure 13.1-11 Position of the primary beam

L=	7	m	
F _{Ek} =	60,35	kN	
F _{Ed} =	83,93	kN	
g _k =	0,4	kN/m	self-weight of the primary beam
g _d =	0,54	kNm	
R _{Ed} =	85,82	kN	
M _{Ed} =	199,14	kNm	

Cross-section	IPE 270		cross section class 1. for bending
A=	4595	mm ²	area of the cross section
m=	36	kg	weight of the cross section
h=	270	mm	



b=	135	mm
t _w =	6,6	mm
t _f =	10,2	mm
W _{y,pl} =	483997	mm ³
I _y =	57897773	mm ⁴
A _{vz} =	2214	mm ²

13.1.7.1. ULS verification

ULS	f _{ck} =	30,00	MPa	
	f _{cd} =	16,000	Mpa	
	E _{cm} =	33	Gpa	
	b _{eff} =	0,875	m	
	N _a =	1631,05	kN	
	x=	116,50	mm	> 112,8 mm=d _c NO

The neutral axis isn't in the concrete slab.

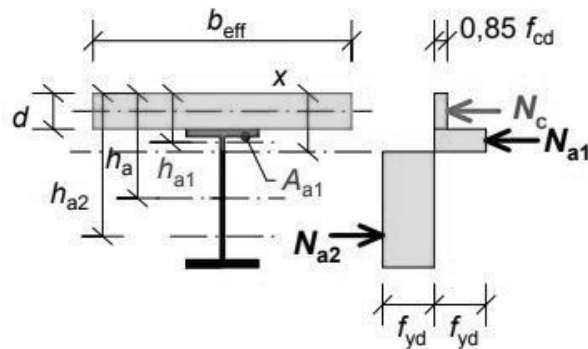

Figure 13.1-12 force balance in the cross section

$$N_c + N_{a1} = N_{a2} \leftrightarrow N_c + 2 \cdot N_{a1} = N_a$$

$$N_c = b_{eff} \cdot d_c \cdot f_{cd} = 875 \cdot 112,8 \cdot 16 = 1580,46 \text{ kN}$$

The neutral axis passes through the upper flange of the beam.

$$N_{a1} = (x - d) \cdot b \cdot f_{yd} = (x - 150) \cdot 135 \cdot 355$$

$$x = \frac{N_a - N_c}{2 \cdot b \cdot f_{yd}} + d = \frac{(1631,05 - 1580,46) \cdot 10^3}{2 \cdot 135 \cdot 355} + 150 = 0,53 + 150 = 150,53 \text{ mm}$$

$$N_{a1} = (x - d) \cdot b \cdot f_{yd} = 0,53 \cdot 135 \cdot 355 = 25,4 \text{ kN}$$



$$\begin{aligned}
 M_{pl,Rd} &= N_a(h_a - d_c/2) - 2 \cdot N_{a1}(h_{a1} - d_c/2) \\
 &= 1631,05 \cdot \left(\frac{270}{2} + \frac{112,8}{2}\right) - 2 \cdot 25,4 \cdot \left(\frac{0,53}{2} + \frac{112,8}{2}\right) \\
 &= 309,39 \text{ kNm} > 199,13 \text{ kNm} = M_{Ed}
 \end{aligned}$$

$$V_{pl,Rd} = A_{vz} \cdot f_{yd}/\sqrt{3} = 2214 \cdot 355/\sqrt{3} = 453,78 \text{ kN} > 85,82 \text{ kN} = V_{Ed}$$

small shear, there is no need to verify the shear and bend interaction.

ULS is OK

13.1.7.2. Shear studs design

d=	25	mm	
h _{cs} =	100	mm	
n _s =	1		the number of studs in the one rib
f _y =	355	MPa	shear studs yield strength
f _u =	490	MPa	shear studs ultimate strength
P _{Rd,1} =	153,938	kN	load capacity of one shear stud
P _{Rd,2} =	144,273	kN	load capacity of one shear stud
h _c /d _s =	4,0		
α=	1		
b ₀ =	81	mm	
k _t =	0,54		
P _{Rd} =	77,908	kN	load capacity of one shear stud
F _{ct} =N=	1631,05	kN	
n _r =	42,00		required number of the studs on the half of the secondary beam.
L/n _r =	166,67	mm	

Shear stud SD 25/100 is designed every 160 mm

13.1.7.3. Serviceability limit state

R _{Ek} =	61,75	kN	
M _{Ek} =	143,28	kNm	
E _c '=	16500	Mpa	
n=	12,727		
A _i =	10782	mm ²	area of the ideal cross-section
e=	296,338		
I _i =	2,335·10 ⁸	mm ⁴	
σ _{a,max} =	181,814	MPa	< 355 MPa OK
σ _{c,max} =	7,408	MPa	< 30 MPa OK



$\delta_2 = 10,4267$ mm < 17,5 mm OK
 $\delta_{max} = 21,7843$ mm < 28 mm OK

OK

IPE270 satisfied for primary outer beam

13.2. Roof construction

$B = 7$ m — loading width

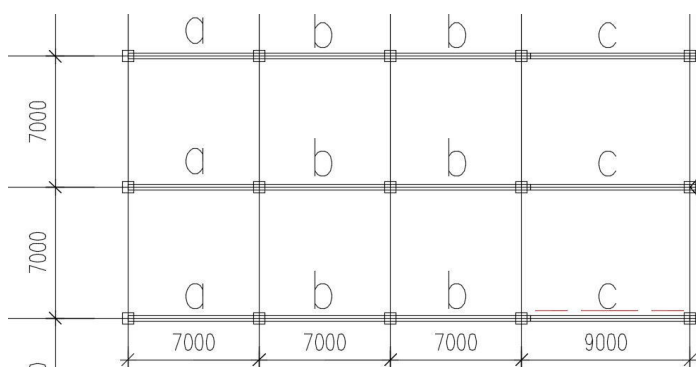

Figure 13.2-1 Sketch of the roof construction

13.2.1. Loads

1. LC - 1. max pressure		kN/m ²	kN/m ²	
1	Permanent	1,4	1,35	1,890
2	Snow s_1	0,488	1,5	0,732
3	Wind (I) * $\psi=0,6$	0,118	1,5	0,177
4	Internal pressure(-0,394) * $\psi=0,6$	0,236	1,5	0,355
		2,242		3,154

Figure 13.2-2 Load on the roof

Snow drifting must be considered at the edge of the roof (beam a):

$$s_2 = 1,22 \text{ kN/m}^2$$

$$s_2 - s_1 = 0,732 \text{ kN/m}^2$$

$$l_s = 5 \text{ m}$$

13.2.2. Design of the roof beams

Beam	a	b	c	
Cross-section	IPE 270	IPE 270	IPE 330	
A=	4595	4595	6261	mm ²
m=	36	36	49	kg



	$W_{y,pl} =$	483997	483997	804331	mm^3
	$I_y =$	57897773	57897773	117668927	mm^4
	$A_{vz} =$	2214	2214	2214	mm^2
	$R_{Ed} =$	87,03	77,273	99,351	kN
	$M_{Ed} =$	154,42	135,23	223,54	kNm
ULS Check	$M_{pl,Rd} =$	171,819	171,819	285,537	kN
	$V_{pl,Rd} =$	453,780	453,780	453,780	kNm
	Verification	OK	OK	OK	
SLS Check	$\delta =$	15,16	15,16	20,38	
	$\delta_{lim} =$	28,0	28,0	36,0	mm
	Verification	OK	OK	OK	

13.3. Columns

The columns are mostly stressed by the central pressure. Bending moments can rise from eccentricity of vertical forces and imperfection. A profile for the most loaded inner column will be designed and used for all internal columns.

13.3.1. Serviceability limit state

First, it is necessary to verify the condition of a permissible horizontal deformation on the columns (HEA240) in software Dlubal RFEM.

In the Czech Republic, it is recommended that the highest values of horizontal deflections δ of building structures be determined as follows:

- multi-storey buildings on each floor:

$$\delta_{lim} = \frac{h}{300} = \frac{5000}{300} = 16,667 \text{ mm}$$

- for the total height of the column:

$$\delta_{lim} = \frac{h_0}{500} = \frac{10264}{500} = 20,538 \text{ mm}$$

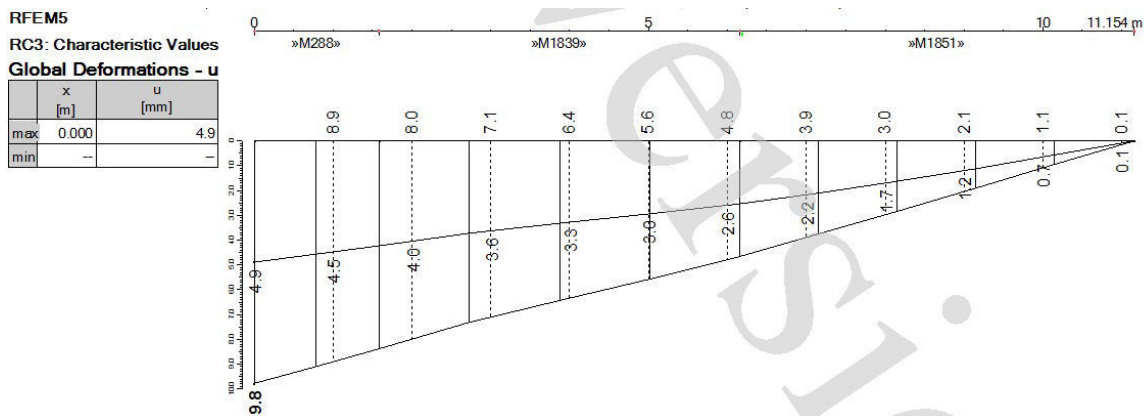

Figure 13.3-1 deformations on the column

$$\delta_1 = 5,8 \text{ mm} < 16,667 \text{ mm} = \delta_{lim}$$

$$\delta_2 = 9,8 \text{ mm} < 20,538 \text{ mm} = \delta_{lim}$$

Deformations is OK for HEA 240

13.3.2. Internal forces

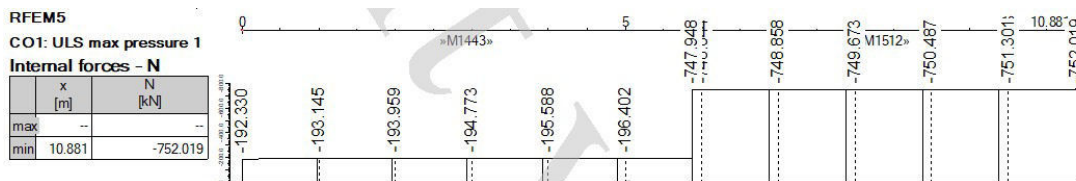

Figure 13.3-2 Internal forces on internal column

$$N_{Ed,max} = 753,173 \text{ kN}$$

Try cross-section **HEA 240** (3. Class for pressure and for bending). Cross-section characteristics:

f_y	= 355	MPa
A	= 7684	mm ²
h	= 230	mm
I_y	= $7,763 \cdot 10^7$	mm ⁴
i_y	= 101	mm
$W_{y,el}$	= 675 058	mm ³
$W_{y,pl}$	= 744 623	mm ³
I_z	= $2,769 \cdot 10^7$	mm ⁴
i_z	= 60	mm
$W_{z,el}$	= 230 734	mm ³



$$\begin{aligned}W_{z,pl} &= 351\,692 && \text{mm}^3 \\I_t &= 415\,519 && \text{mm}^4 \\I_w &= 3,285 \cdot 10^{11} && \text{mm}^4 \\N_{Rd} &= 2\,727,66 && \text{kN} \\M_{y,Rd} &= 239,65 && \text{kNm}\end{aligned}$$

13.3.3. Buckling coefficients

$$\begin{aligned}L_{cr,y} &= 5,881 && \text{m} && \text{buckling length in the buckling plane} \\ \lambda_y &= 58,508 \\ \lambda_{rel,y} &= 0,766 && \text{slenderness for flexural buckling} \\ \alpha &= 0,34 && \text{Imperfection factors for buckling curves} \\ \phi_y &= 0,889 \\ \chi_y &= 0,745 && \text{reduction factor} \\ L_{cr,z} &= 5,881 && \text{m} && \text{buckling length in the buckling plane} \\ \lambda_z &= 97,968 \\ \lambda_{rel,z} &= 1,282 && \text{slenderness for flexural buckling} \\ \alpha &= 0,49 && \text{Imperfection factors for buckling curves} \\ \phi_z &= 1,587 \\ \chi_z &= 0,396 && \text{reduction factor}\end{aligned}$$

$$\frac{N_{Ed}}{\chi_y \cdot N_{Rd}} = \frac{758,13 \cdot 10^3}{0,745 \cdot 2727 \cdot 10^3 / 1} = \mathbf{0,373} \leq \mathbf{1}$$

$$\frac{N_{Ed}}{\chi_z \cdot N_{Rd}} = \frac{758,13 \cdot 10^3}{0,396 \cdot 2727 \cdot 10^3 / 1} = \mathbf{0,701} \leq \mathbf{1}$$

HEA 240 is OK



14. Connections

14.1. Truss connection

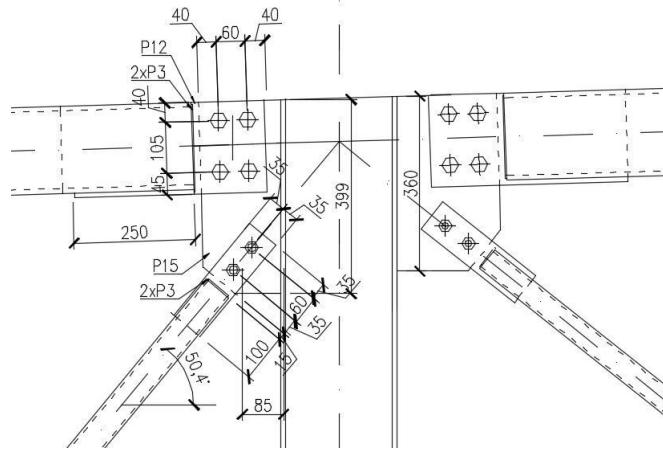

Figure 14.1-1 Truss connection

14.1.1. Upper chord connection

Upper chord was designed in 9.6. Cross-section SHS 180x10 (S355).

$$N_{Ed} = -464,7 \text{ kN}$$

$$V_z = 22,96 \text{ kN}$$

$$F_{Ed} = \sqrt{464,7^2 + 22,96^2} = 465,27 \text{ kN}$$

$$M_{Ed} = 0 \text{ kNm}$$

$$f_y = 355 \text{ MPa} \text{ — yield strength of the plate material}$$

$$f_u = 490 \text{ MPa} \text{ — ultimate strength of the plate material}$$

- Welds resistance:

$$L_{a1} = 250 \text{ mm} \text{ — length of the horizontal welds}$$

$$L_{a2} = 180 \text{ mm} \text{ — length of the vertical welds}$$

$$a_{a1} = 4 \text{ mm} \text{ — thickness of the horizontal weld}$$

$$a_{a2} = 3 \text{ mm} \text{ — thickness of the vertical weld}$$

$$\tau_{\parallel,1} = \frac{N_{Ed}}{4 \cdot a_w \cdot L_{a1}} = \frac{464,7 \cdot 10^3}{4 \cdot 4 \cdot 250} = 116,2 \text{ MPa}$$



$$\sqrt{3\tau_{\parallel,1}^2} = \sqrt{3 \cdot 116,2^2} = 201,3 \text{ MPa} < \mathbf{435,556 \text{ MPa}} = \frac{f_u}{\beta_w \cdot \gamma_{M2}}$$
$$= \frac{490}{0,9 \cdot 1,25}$$

$$\tau_{\parallel,2} = \frac{V_{Ed}}{2 \cdot a_w \cdot L_{a2}} = \frac{22,96 \cdot 10^3}{2 \cdot 3 \cdot 180} = 15 \text{ MPa}$$

$$\sqrt{3\tau_{\parallel,1}^2} = \sqrt{3 \cdot 15^2} = 26 \text{ MPa} < \mathbf{435,556 \text{ MPa}} = \frac{f_u}{\beta_w \cdot \gamma_{M2}} = \frac{490}{0,9 \cdot 1,25}$$

- Bolts resistance:

$t = 12 \text{ mm}$ — thickness of the plate

$d = 20 \text{ mm}$

$d_0 = 22 \text{ mm}$

$A = 314,2 \text{ mm}^2$ — cross-section of the bolt

$e_1 = 35 \text{ mm}$

$e_2 = 75 \text{ mm}$

$p_1 = p_2 = 60 \text{ mm}$

$n = 4$ — number of the bolts

$f_{ub} = 800 \text{ MPa}$ — ultimate tensile strength of the bolt

Shear resistance:

$$F_{v,Rd,1} = \frac{0,6 \cdot A \cdot f_{ub}}{\gamma_{M2}} = \frac{0,6 \cdot 314,2 \cdot 800}{1,25} = 120,64 \text{ kN}$$

$$F_{v,Rd} = 4 \cdot 120,64 = 482,5 \geq 465,27 = F_{Ed}$$

Bearing resistance:

$$k_1 = \min\left(2,8 \cdot \frac{e_2}{d_0} - 1,7; 2,5\right) = \min(7,85; 2,5) = 2,5$$

$$\alpha_b = \min\left(\frac{e_1}{3 \cdot d_0}; \frac{p_1}{3d_0} - 0,25; \frac{f_{ub}}{f_u}; 1,0\right) = \min(0,53; 0,66; 1,633; 1)$$
$$= 0,53$$

$$F_{b,Rd,1} = \frac{k_1 \cdot \alpha_b \cdot d \cdot t \cdot f_u}{\gamma_{M2}} = \frac{2,5 \cdot 0,53 \cdot 20 \cdot 12 \cdot 490}{1,25} = 124,64 \text{ kN}$$

$$F_{b,Rd} = 4 \cdot 124,64 \text{ kN} = 498,91 \text{ kN} > 465,27 \text{ kN} = F_{Ed}$$



- Plate resistance:

$$A = 190 \cdot 12 = 2280 \text{ mm}^2$$

$$A_{net} = A - 2 \cdot 22 \cdot 12 = 1752 \text{ mm}^2$$

$$N_{pl,Rd} = A \cdot \frac{f_y}{\gamma_{M0}} = 2280 \cdot \frac{355}{1,0} = 809,4 \text{ kN} > 465,27 \text{ kN} = F_{Ed}$$

$$N_{u,Rd} = 0,9 A_{net} \cdot \frac{f_u}{\gamma_{M2}} = 0,9 \cdot 1752 \cdot \frac{490}{1,25} = 549,4 \text{ kN} > 465,27 \text{ kN} = F_{Ed}$$

- Block tearing resistance:

$$A_{nt} = 12 \cdot 103 = 1236 \text{ mm}^2$$

$$A_{nv} = 12 \cdot 2 \cdot (38 + 24) = 1488 \text{ mm}^2$$

$$V_{eff,1,Rd} = \frac{A_{nt} \cdot f_u \cdot 0,9}{\gamma_{M2}} + \frac{A_{nv} \cdot f_y}{\sqrt{3} \cdot \gamma_{M0}} = \frac{1236 \cdot 490 \cdot 0,9}{1,25} + \frac{1488 \cdot 355}{\sqrt{3} \cdot 1}$$

$$= 436,1 + 304,98 = 741,1 \text{ kN} > 465,3 \text{ kN}$$

$$A_{nt} = 12 \cdot (34 + 29) = 756 \text{ mm}^2$$

$$A_{nv} = 12 \cdot 2 \cdot (38 + 24) = 1488 \text{ mm}^2$$

$$V_{eff,1,Rd} = \frac{A_{nt} \cdot f_u \cdot 0,9}{\gamma_{M2}} + \frac{A_{nv} \cdot f_y}{\sqrt{3} \cdot \gamma_{M0}} = \frac{756 \cdot 490 \cdot 0,9}{1,25} + \frac{1488 \cdot 355}{\sqrt{3} \cdot 1}$$

$$= 571,7 \text{ kN} > 465,3 \text{ kN}$$

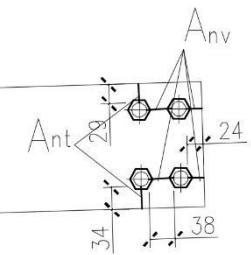
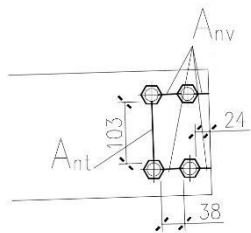

CONNECTION IS OK

14.1.2. Diagonal connection

Diagonal cross-section was designed in 15.2.2 Cross-section SHS 90x8 (D1) — see page 52.

$$N_{Ed} = -46,75 \text{ kN}$$

$$V_z = 0 \text{ kN}$$

$$M_{Ed} = 0 \text{ kNm}$$

$$F_{Ed} = 46,75 \text{ kN}$$

- Welds resistance:

$$L_{b1} = 100 \text{ mm} \text{ — length of the longitudinal welds}$$

$$a_{b1} = 4 \text{ mm} \text{ — thickness of the longitudinal weld}$$

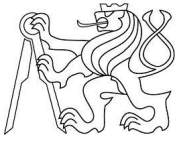

$a_{b2} = 3 \text{ mm}$ — thickness of the transversal (construction) weld

$$\tau_{\parallel,1} = \frac{N_{Ed}}{4 \cdot a_w \cdot L_{a1}} = \frac{46,75 \cdot 10^3}{4 \cdot 4 \cdot 100} = 29,2 \text{ MPa}$$

$$\sqrt{3\tau_{\parallel,1}^2} = \sqrt{3 \cdot 29,2^2} = 50,61 \text{ MPa} < \mathbf{435,556 \text{ MPa}} = \frac{f_u}{\beta_w \cdot \gamma_{M2}}$$
$$= \frac{490}{0,9 \cdot 1,25}$$

- Bolts resistance:

$t = 12 \text{ mm}$ — thickness of the plate

$d = 20 \text{ mm}$

$d_0 = 22 \text{ mm}$

$A = 314,2 \text{ mm}^2$ — cross-section of the bolt

$e_1 = 35 \text{ mm}$

$e_2 = 35 \text{ mm}$

$p_1 = p_2 = 60 \text{ mm}$

$n = 2$ — number of the bolts

$f_{ub} = 800 \text{ MPa}$ — ultimate tensile strength of the bolt

Shear resistance:

$$F_{v,Rd,1} = \frac{0,6 \cdot A \cdot f_{ub}}{\gamma_{M2}} = \frac{0,6 \cdot 314,2 \cdot 800}{1,25} = 120,64 \text{ kN}$$

$$F_{v,Rd} = 2 \cdot 120,64 = 241,3 \geq 46,75 = F_{Ed}$$

Bearing resistance:

$$k_1 = \min\left(2,8 \cdot \frac{e_2}{d_0} - 1,7; 2,5\right) = \min(2,75; 2,5) = 2,5$$

$$\alpha_b = \min\left(\frac{e_1}{3 \cdot d_0}; \frac{p_1}{3d_0} - 0,25; \frac{f_{ub}}{f_u}; 1,0\right) = \min(0,53; 0,66; 1,633; 1)$$
$$= 0,53$$

$$F_{b,Rd,1} = \frac{k_1 \cdot \alpha_b \cdot d \cdot t \cdot f_u}{\gamma_{M2}} = \frac{2,5 \cdot 0,53 \cdot 20 \cdot 12 \cdot 490}{1,25} = 124,73 \text{ kN}$$

$$F_{b,Rd} = 2 \cdot 124,73 \text{ kN} = 249,46 \text{ kN} > 46,75 \text{ kN} = F_{Ed}$$



- Plate resistance:

$$A = 70 \cdot 12 = 840 \text{ mm}^2$$

$$A_{net} = A - 2 \cdot 22 \cdot 12 = 576 \text{ mm}^2$$

$$N_{pl,Rd} = A \cdot \frac{f_y}{\gamma_{M0}} = 840 \cdot \frac{355}{1,0} = 298,2 \text{ kN} > 46,75 \text{ kN} = F_{Ed}$$

$$N_{u,Rd} = 0,9A_{net} \cdot \frac{f_u}{\gamma_{M2}} = 0,9 \cdot 576 \cdot \frac{490}{1,25} = 203,2 \text{ kN} > 46,75 \text{ kN} = F_{Ed}$$

14.1.3. Plate weld to a column

First, it is necessary to convert the internal forces from the upper chord and diagonal to the column's local coordinate system.

$$N_{Ed,1} = 464,7 \text{ kN}$$

$$V_{Ed,1} = 22,96 \text{ kN}$$

$$N_{Ed,2} = 46,75 \text{ kN}$$

$$\alpha_1 = 1,7^\circ \text{ — upper chord angle}$$

$$\alpha_2 = 50,4^\circ \text{ — diagonal D14 angle}$$

$$\begin{aligned} F_{x,1} &= N_{Ed,1} \cdot \cos(\alpha_1) - V_{Ed,1} \cdot \sin(\alpha_1) \\ &= 464,7 \cdot \cos(1,7) - 22,96 \cdot \sin(1,7) = 463,8 \text{ kN} \end{aligned}$$

$$\begin{aligned} F_{y,1} &= N_{Ed,1} \cdot \sin(\alpha_1) + V_{Ed,1} \cdot \cos(\alpha_1) \\ &= 464,7 \cdot \sin(1,7) + 22,96 \cdot \cos(1,7) = 36,7 \text{ kN} \end{aligned}$$

$$F_{x,2} = N_{Ed,2} \cdot \cos(\alpha_2) = -46,75 \cdot \cos(50,4) = -29,8 \text{ kN}$$

$$F_{y,2} = N_{Ed,2} \cdot \sin(\alpha_2) = -46,75 \cdot \sin(50,4) = 36,0 \text{ kN}$$

$$e_1 = \max(113; 138) = 138 \text{ mm}$$

$$e_2 = \max(85; 119) = 119 \text{ mm}$$

$$L_w = 380 \text{ mm}$$

$$n = 2 \text{ — number of the welds}$$

$$a_w = 5 \text{ mm}$$

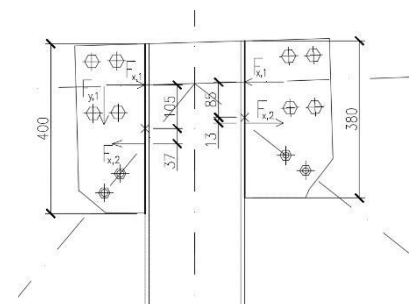
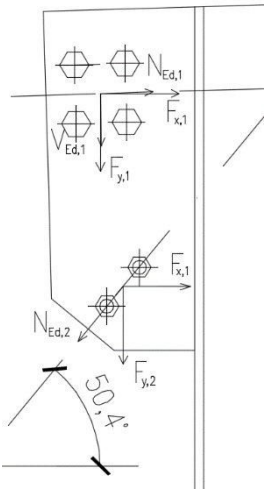

Figure 14.1-2 Scheme of the column weld



$$\begin{aligned}\sigma_{\perp} = \tau_{\perp} &= \frac{1}{\sqrt{2}} \left(\frac{F_{x,1} + F_{x,2}}{2 \cdot a_w \cdot L_w} + \frac{F_{x,1} \cdot e_1 + F_{x,2} \cdot e_2}{\frac{2}{6} \cdot a_w \cdot L_w^2} \right) \\ &= \frac{1}{\sqrt{2}} \cdot \frac{463,8 - 29,8}{2 \cdot 5 \cdot 380} + \frac{1}{\sqrt{2}} \cdot \frac{463,8 \cdot 85 - 29,8 \cdot 13}{\frac{2}{6} \cdot 5 \cdot L_w^2} \\ &= 80,8 + 114,7 = 195,5 \text{ MPa}\end{aligned}$$

$$\tau_{\parallel} = \frac{F_{y,1} + F_{y,2}}{2 \cdot a_w \cdot L_w} = \frac{36,74 + 36,02}{2 \cdot 5 \cdot 380} = 19,2 \text{ MPa}$$

$$\begin{aligned}\sqrt{\sigma_{\perp}^2 + 3(\tau_{\perp} + \tau_{\parallel})^2} &= 419,96 \text{ MPa} \leq 435,556 \text{ MPa} = \frac{f_u}{\beta_w \cdot \gamma_{M2}} \\ &= \frac{490}{0,9 \cdot 1,25}\end{aligned}$$

$$\sigma_{\perp} = 195,5 \text{ MPa} \leq 392 \text{ MPa} = \frac{f_u}{\gamma_{M2}} = \frac{490}{1,25}$$

Connection is OK

14.2. Diagonal members and upper chord joints

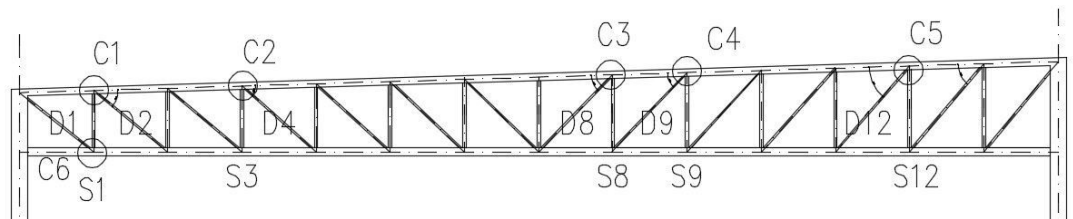

Figure 14.2-1 Members and joints numbering for verification

These joints have been designed to satisfy requirements in table 7.12 or 7.10 in EN 1993-1-8 and thus, they have been checked for strength (joint design axial resistance), depending on joint type.

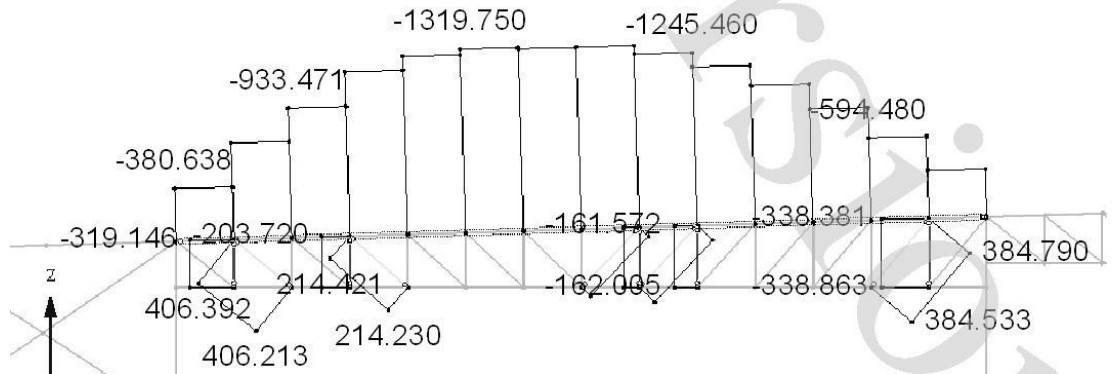

Figure 14.2-2 Internal forces in the selected members

The following calculation procedure is according to the Eurocode [5]. The C1 (gap) will be calculated in detail:

SHS	180x10	
A_0	6690	mm ²
f_{y0}	355	MPa
f_u	490	MPa
b_0	180	mm
t_0	12,5	mm
b_0/t_0	14,4	OK
γ	7,2	

$f_u/(\beta_w \cdot \gamma_{M2})$	435,6	MPa
$f_u/1,25$	392	MPa

Joint	C1:	
b_1	80	mm
t_1	5	mm
f_{y1}	355	MPa
b_2	70	mm
t_2	5	mm
f_{y2}	355	MPa
$N_{Ed,1}$	380,454	kN
$N_{Ed,2}$	695,458	kN
$N_{Ed,3}$	319,146	kN
$N_{Ed,4}$	406,392	kN
θ_1	88,3	°
θ_2	41,13	°
g	12,50	mm

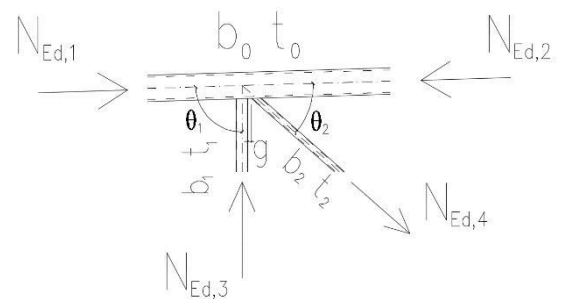

Figure 14.2-3 Scheme of gap joint



Range of validity:

$$\begin{aligned}b_1/b_0 &= 0,444 \geq 0,35 \text{ OK} \\b_2/b_0 &= 0,389 \geq 0,35 \text{ OK} \\b_1/t_1 &= 16 \leq 35 \text{ OK} \\b_2/t_2 &= 14 \leq 35 \text{ OK} \\t_1+t_2 &= 10 \leq g \text{ OK}\end{aligned}$$

Connections C3, C4 and C6 do not match the range of validity. Their load capacity was verified in software IDEA Statica.

The stresses in the chord at a joint should be determined from:

$$\sigma_{1,Ed} = \frac{N_{1,Ed}}{A_0} = 56,87 \text{ MPa}$$

$$\sigma_{2,Ed} = \frac{N_{2,Ed}}{A_0} = 103,95 \text{ MPa}$$

$$n = \frac{\sigma_{2,Ed}}{f_y \cdot \gamma_{M5}} = \frac{103,95}{355 \cdot 1,0} = 0,293$$

$$\beta = \frac{b_1 + b_2}{2 \cdot b_0} = 0,375$$

$$k_n = \min\left(1,3 - \frac{0,4 \cdot n}{\beta}; 1\right) = 0,988$$

$$\gamma = \frac{b_0}{2t_0} = \frac{180}{2 \cdot 10} = 9$$

$$b_{eff,1} = \frac{10}{b_0/t_0} \cdot \frac{f_{y0} \cdot t_0 \cdot b_1}{f_{y1} \cdot t_1} = \frac{10}{180/12,5} \cdot \frac{355 \cdot 12,5 \cdot 80}{355 \cdot 5} = 138,9 \text{ mm}$$

$$b_{eff,2} = \frac{10}{b_0/t_0} \cdot \frac{f_{y0} \cdot t_0 \cdot b_2}{f_{y2} \cdot t_2} = \frac{10}{180/12,5} \cdot \frac{355 \cdot 12,5 \cdot 70}{355 \cdot 5} = 121,5 \text{ mm}$$

Design axial resistance of welded N joints:

Chord face failure:

$$\begin{aligned}N_{1,Rd} &= \frac{8,9 \cdot k_n \cdot f_y \cdot t_0^2 \cdot \sqrt{\gamma}}{\gamma_{M5} \cdot \sin(\theta_1)} \cdot \frac{b_1 + b_2}{2b_0} \\&= \frac{8,9 \cdot 0,988 \cdot 355 \cdot 12,5^2 \cdot \sqrt{7,2}}{1,0 \cdot \sin(88,3)} \cdot \frac{80 + 70}{2 \cdot 180} = 545,4 \text{ kN} \\&> 319,15 \text{ kN}\end{aligned}$$



$$\begin{aligned} N_{2,Rd} &= \frac{8,9 \cdot k_n \cdot f_y \cdot t_0^2 \cdot \sqrt{\gamma}}{\gamma_{M5} \cdot \sin(\theta_2)} \cdot \frac{b_1 + b_2}{2b_0} \\ &= \frac{8,9 \cdot 0,988 \cdot 355 \cdot 12,5^2 \cdot \sqrt{7,2}}{1,0 \cdot \sin(41,13)} \cdot \frac{80 + 70}{2 \cdot 180} = 828,7 \text{ kN} \\ &> 406,392 \text{ kN} \end{aligned}$$

Chord shear:

$$N_{1,Rd} = \frac{f_{y0} \cdot A_v}{\sqrt{3} \cdot \gamma_{M5} \cdot \sin(\theta_1)} = \frac{355 \cdot 2 \cdot 180 \cdot 12,5}{\sqrt{3} \cdot 1,0 \cdot \sin(88,3)} = 922,7 \text{ kN} > 319,15 \text{ kN}$$

$$\begin{aligned} N_{2,Rd} &= \frac{f_{y0} \cdot A_v}{\sqrt{3} \cdot \gamma_{M5} \cdot \sin(\theta_2)} = \frac{355 \cdot 2 \cdot 180 \cdot 12,5}{\sqrt{3} \cdot 1,0 \cdot \sin(41,13)} = 1402,2 \text{ kN} \\ &> 406,392 \text{ kN} \end{aligned}$$

Vertical member failure:

$$\begin{aligned} N_{1,Rd} &= \frac{f_{y1} \cdot t_1}{\gamma_{M5}} \cdot (2h_1 - 4t_1 + b_1 + b_{eff,1}) \\ &= \frac{355 \cdot 5}{1,0} \cdot (2 \cdot 80 - 4 \cdot 5 + 80 + 138,9) = 637 \text{ kN} \\ &> 319,15 \text{ kN} \end{aligned}$$

Diagonal member failure:

$$\begin{aligned} N_{2,Rd} &= \frac{f_{y2} \cdot t_2}{\gamma_{M5}} \cdot (2h_2 - 4t_2 + b_2 + b_{eff,2}) \\ &= \frac{355 \cdot 5}{1,0} \cdot (2 \cdot 70 - 4 \cdot 5 + 70 + 121,5) = 553 \text{ kN} \\ &> 406,392 \text{ kN} \end{aligned}$$

Punching shear:

$$\begin{aligned} N_{1,Rd} &= \frac{f_{y0} \cdot t_0}{\sqrt{3} \cdot \gamma_{M5} \cdot \sin(\theta_1)} \cdot \left(\frac{2h_1}{\sin(\theta_1)} + b_1 + b_{e,p} \right) \\ &= \frac{355 \cdot 12,5}{\sqrt{3} \cdot 1,0 \cdot \sin(88,3)} \cdot \left(\frac{2 \cdot 80}{\sin(88,3)} + 80 + \frac{10 \cdot 80}{180/12,5} \right) \\ &= 757,7 \text{ kN} > 319,15 \text{ kN} \end{aligned}$$

$$\begin{aligned} N_{2,Rd} &= \frac{f_{y0} \cdot t_0}{\sqrt{3} \cdot \gamma_{M5} \cdot \sin(\theta_2)} \cdot \left(\frac{2h_2}{\sin(\theta_2)} + b_2 + b_{e,p} \right) \\ &= \frac{355 \cdot 12,5}{\sqrt{3} \cdot 1,0 \cdot \sin(41,13)} \cdot \left(\frac{2 \cdot 70}{\sin(41,13)} + 70 + \frac{10 \cdot 70}{180/12,5} \right) \\ &= 1291 \text{ kN} > 406,392 \text{ kN} \end{aligned}$$



Welds:

$$a_{w3} = 4 \text{ mm}$$

$$L_{w3} = 4 \cdot b_3 = 4 \cdot 80 = 320 \text{ mm}$$

$$\sigma_{\perp,4} = \tau_{\perp,4} = \frac{1}{\sqrt{2}} \left(\frac{N_{Ed,3}}{a_{w3} \cdot L_{w3}} \right) = 176,27 \text{ MPa}$$

$$\leq 392 \text{ MPa} = \frac{f_u}{\gamma_{M2}} = \frac{490}{1,25}$$

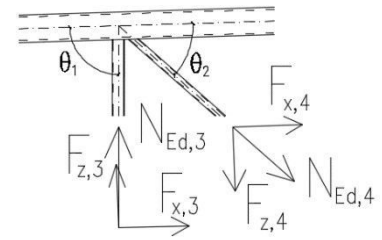

$$\sqrt{\sigma_{\perp}^2 + 3(\tau_{\perp})^2} = 305 \text{ MPa} \leq 435,556 \text{ MPa} = \frac{f_u}{\beta_w \cdot \gamma_{M2}} = \frac{490}{0,9 \cdot 1,25}$$

$$F_{x,4} = N_{Ed,4} \cdot \cos\theta_4 = 406,392 \cdot \cos(41,13) = 306,1 \text{ kN}$$

$$F_{z,4} = N_{Ed,4} \cdot \sin\theta_4 = 406,392 \cdot \sin(41,13) = 267,3 \text{ kN}$$

$$a_{w4} = 7 \text{ mm}$$

$$\sigma_{\perp,4} = \tau_{\perp,4} = \frac{1}{\sqrt{2}} \left(\frac{F_{z,4}}{2 \cdot a_{w4} \cdot b_4 \cdot (1/\cos\theta_2 + 1)} \right) = 94,89 \text{ MPa} \leq 392 \text{ MPa}$$

$$= \frac{f_u}{\gamma_{M2}} = \frac{490}{1,25}$$

$$\tau_{\parallel,4} = \frac{F_{x,4}}{2 \cdot a_{w4} \cdot b_4 (1/\cos(\theta_2) + 1)} = 134,19 \text{ MPa}$$

$$\sqrt{\sigma_{\perp}^2 + 3(\tau_{\perp} + \tau_{\parallel})^2} = 397 \text{ MPa} \leq 435,556 \text{ MPa} = \frac{f_u}{\beta_w \cdot \gamma_{M2}}$$

$$= \frac{490}{0,9 \cdot 1,25}$$

$$\sigma_{\perp} = 193,1 \text{ MPa} \leq 392 \text{ MPa} = \frac{f_u}{\gamma_{M2}} = \frac{490}{1,25}$$

$$a_{w3} + a_{w4} = 11 \text{ mm} < g = 12,5 \text{ mm} \text{ — OK}$$

Join C1 and the remaining connections will be verified in the IDEA StatiCa software (see attachment). The input data are summarized in the following table.

	C1	C2	C3	C4	C5
SHS1=	80x5	60x5	60x5	70x4	80x5
SHS2=	70x5	50x4	40x4	40x4	70x5
b ₁ =	80 mm	70 mm	60 mm	70 mm	80 mm
t ₁ =	5 mm	4 mm	5 mm	4 mm	5 mm
f _{y1} =	355 MPa	355 MPa	355 MPa	355 MPa	355 MPa
b ₂ =	70 mm	70 mm	40 mm	40 mm	70 mm



$t_2=$	5 mm	4 mm	4 mm	4 mm	5 mm
$f_{y2}=$	355 MPa	355 MPa	355 MPa	355 MPa	355 MPa
$N_{Ed,3} =$	319,146 kN	203,7 kN	114,287 kN	161,6 kN	338,4 kN
$N_{Ed,4} =$	406,392 kN	214,4 kN	90,57 kN	152,4 kN	384,8 kN
$\theta_1=$	88,3 °	88,3 °	91,7 °	91,7 °	91,7 °
$\theta_2=$	41,13 °	43,14 °	44,2 °	45,03 °	48,1 °

Table 14.2-1 Input data of selected joints

14.3. Bolted connection on the lower chord

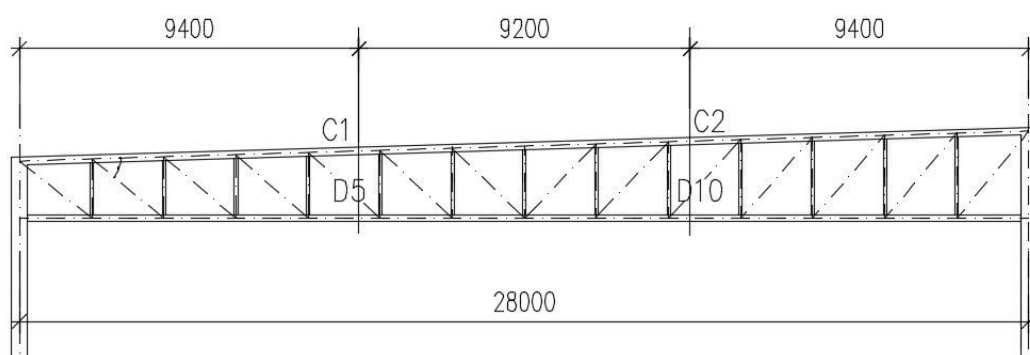

Figure 14.3-1 Placement of the bolted connections

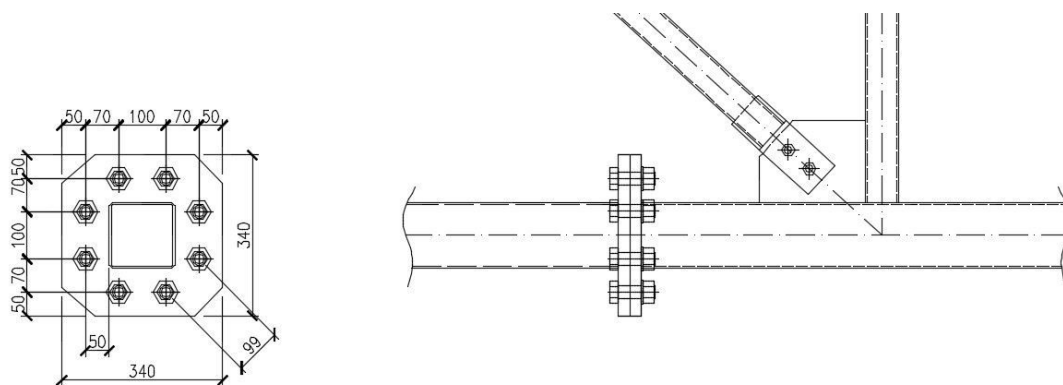
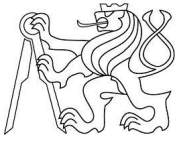

Figure 14.3-2 Scheme of the connection

$N_{Ed,C1} = 1103,4 \text{ kN}$ — internal force in lower chord (C1) see Figure 5.2-1 (page 28)

$N_{Ed,D5} = 10,6 \text{ kN}$ — internal force in diagonal D5

$N_{Ed,C2} = 917,54 \text{ kN}$ — internal force in lower chord (C2) see Figure 5.2-1 (page 28)



$N_{Ed,D10} = 15,22 \text{ kN}$ — internal force in diagonal D10

Plate weld to the lower chord

$L_a = P = 548 \text{ mm}$ — perimeter of the lower chord

$a = 6 \text{ mm}$

$$\sigma_{\perp} = \tau_{\perp} = \frac{1}{\sqrt{2}} \left(\frac{N_{Ed,max}}{2 \cdot a_w \cdot L_w} \right) = \frac{1}{\sqrt{2}} \left(\frac{1103,4 \cdot 10^3}{7 \cdot 548} \right) = 203,4 \text{ MPa}$$
$$\leq 392 \text{ MPa} = \frac{f_u}{\gamma_{M2}} = \frac{490}{1,25}$$

$$\sqrt{\sigma_{\perp}^2 + 3(\tau_{\perp} + \tau_{\parallel})^2} = 406,8 \text{ MPa} \leq 435,556 \text{ MPa} = \frac{f_u}{\beta_w \cdot \gamma_{M2}}$$
$$= \frac{490}{0,9 \cdot 1,25}$$

14.3.1. Bolt resistance

Bolts: 8xM27 10.9

$t = 25 \text{ mm}$ — thickness of the plate

$f_u = 490 \text{ MPa}$

$d = 27 \text{ mm}$

$d_0 = 30 \text{ mm}$

$A = 572,6 \text{ mm}^2$ — cross-section of the bolt

$A_s = 452,4 \text{ mm}^2$

$e_1 = 50 \text{ mm}$

$e_2 = 50 \text{ mm}$

$p_1 = p_2 = 100 \text{ mm}$

$n = 8$ — number of the bolts

$f_{ub} = 1000 \text{ MPa}$ — ultimate tensile strength of the bolt

Tension resistance:

$$F_{t,Rd,1} = \frac{0,9 \cdot A_s \cdot f_{ub}}{\gamma_{M2}} = \frac{0,9 \cdot 452,4 \cdot 1000}{1,25} = 325,7 \text{ kN}$$

$$F_{t,Rd} = 8 \cdot 325,7 = 2605,8 \text{ kN} \geq 1103,4 = N_{Ed}$$



Shear resistance:

$$F_{v,Rd,1} = \frac{0,6 \cdot A \cdot f_{ub}}{\gamma_{M2}} = \frac{0,6 \cdot 572,6 \cdot 1000}{1,25} = 274,8 \text{ kN}$$

$$F_{v,Rd} = 8 \cdot 274,8 = 2198,6 \geq 1103,4 = N_{Ed}$$

Bearing resistance:

$$k_1 = \min\left(2,8 \cdot \frac{e_2}{d_0} - 1,7; 2,5\right) = \min(2,97; 2,5) = 2,5$$

$$\alpha_b = \min\left(\frac{e_1}{3 \cdot d_0}; \frac{p_1}{3d_0} - 0,25; \frac{f_{ub}}{f_u}; 1,0\right) = \min(0,556; 8,861; 1,633; 1) \\ = 0,556$$

$$F_{b,Rd,1} = \frac{k_1 \cdot \alpha_b \cdot d \cdot t \cdot f_u}{\gamma_{M2}} = \frac{2,5 \cdot 0,556 \cdot 27 \cdot 25 \cdot 490}{1,25} = 367,5 \text{ kN}$$

$$F_{b,Rd} = 8 \cdot 367,5 \text{ kN} = 2940 \text{ kN} \geq 1103,4 = N_{Ed}$$

14.3.2. Prying action

Bolt-row considered individually

$$m_x = 50 - 6,8 = 42,1 \text{ mm}$$

$$l_{eff,cp} = \min(2\pi m_x; \pi m_x + w; \pi m_x + 2e) \\ = \min(2\pi \cdot 42,1; \pi \cdot 42,1 + 100; \pi \cdot 42,1 + 2 \cdot 50) \\ = \min(264,4; 232,2; 232,2) = 232,2 \text{ mm}$$

$$l_{eff,nc} = \min(4 \cdot m_x + 1,25e_x; e + 2m_x + 0,625e_x; 0,5b_p; 0,5w + 2m_x \\ + 0,625e_x) \\ = \min(4 \cdot 42,1 + 1,25 \cdot 50; 50 + 2 \cdot 42,1 + 0,625 \cdot 50; 0,5 \cdot 320; 0,5 \cdot 100 + 2 \cdot 42,1 + 0,625 \cdot 50) \\ = \min(230,8; 165,4; 170; 165,4) = 165,4 \text{ mm}$$

$$l_{eff,1} = \min(l_{eff,cp}; l_{eff,nc}) = 165,4 \text{ mm}$$

$$l_{eff,2} = l_{eff,nc} = 165,4 \text{ mm}$$

$$M_{pl,1,Rd} = 0,25 \cdot l_{eff,1} \cdot t_{fc}^2 \cdot \frac{f_y}{\gamma_{M0}} = 0,25 \cdot 165,4 \cdot 20^2 \cdot \frac{355}{1} = 9,175 \text{ kNm}$$

$$M_{pl,2,Rd} = 0,25 \cdot l_{eff,2,Rd} \cdot t_{fc}^2 \cdot \frac{f_y}{\gamma_{M0}} = 9,175 \text{ kNm}$$

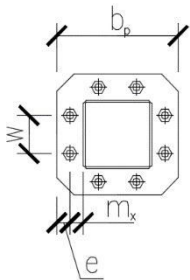



Complete yielding of the flange:

$$F_{T,1,Rd} = \frac{4 \cdot M_{pl,1,Rd}}{m} = \frac{4 \cdot 9,175 \cdot 10^6}{50} = 734 \text{ kN}$$

Bolt failure with yielding of the flange:

$$F_{t,2,Rd} = \frac{2 \cdot M_{pl,2,Rd} + n \sum F_{t,Rd}}{m + n} = \frac{2 \cdot 9,175 + 50 \cdot 651,4}{50 + 50} = 509,23 \text{ kN}$$

Bolt failure:

$$F_{t,c,Rd} = \sum F_{t,Rd} = 2 \cdot 325,7 = 651,4 \text{ kN}$$

Bolt resistance:

$$F_{t,1,Rd} = 4 \cdot \min(F_{t,a,Rd}; F_{t,b,Rd}; F_{t,c,Rd}) = 4 \cdot 509,23 = 2036,92 \text{ kN} \\ > 1103,4 \text{ kN}$$

14.4. Bracing connection

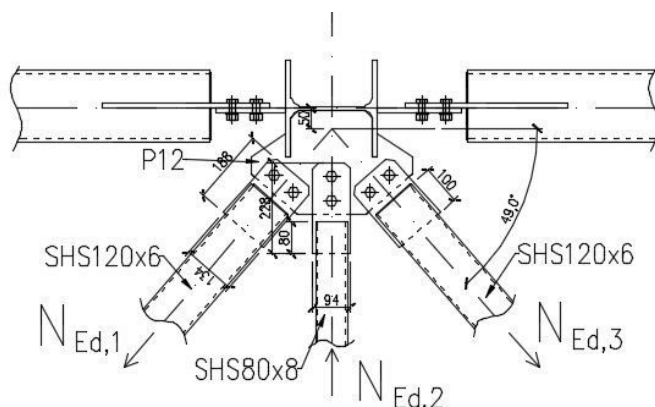

Figure 14.4-1 Scheme of the roof bracing connection

Four symmetrically placed bracing system are designed to carry horizontal load in the transverse direction (perpendicular to the length of the building). These bracing transfer wind load and forces exerted by the columns' imperfections to the foundation. Using the same calculation procedure as in the chapter 14.1.2 (page 106), the results will be shown in the following table.

i=	1	2	3
$N_{Ed,i}$	-64,72 kN	64,06 kN	-82,31 kN
f_y	355 MPa	355 MPa	355 MPa
f_u	490 MPa	490 MPa	490 MPa



Plate geometry	$f_u/(\beta_w \cdot \gamma_{M2})=$	435,6	MPa	435,6	MPa	435,6	MPa
	$A_a=$	188	mm	298	mm	188	mm
	$B_a=$	134	mm	94	mm	134	mm
	$L_{a1}=$	100	mm	80	mm	100	mm
	$a_{w1}=$	3	mm	3	mm	3	mm
Welds	$n_1=$	4		4		4	
	$\tau_{II,1}=$	53,933	MPa	66,725	MPa	68,589	MPa
	$\sigma=$	93,42	MPa	115,57	MPa	118,80	MPa
Bolts	$t=$	12	mm	12	mm	12	mm
	$d=$	16	mm	16	mm	16	mm
	$d_0=$	18	mm	18	mm	18	mm
	$A=$	201,1	mm ²	201,1	mm ²	201,1	mm ²
	$e_1=$	35	mm	35	mm	35	mm
	$e_2=$	35	mm	35	mm	35	mm
	$p_1=$	60	mm	60	mm	60	mm
	$f_{ub}=$	800	MPa	800	MPa	800	MPa
	$n=$	2		2		2	

Shear resistance

$F_{v,Rd,1}=$	77,21	kN	77,21	kN	77,21	kN
$F_{v,Rd}=$	154,4	kN OK	154,4	kN OK	154,4	kN OK

Bearing resistance

$K_1=$ (min)	3,74	3,74	3,74			
	2,5	2,5	2,5			
$a_b=$ (min)	0,648	0,648	0,648			
	0,648	0,648	0,648			
	1,633	1,633	1,633			
	1	1	1			
$F_{v,Rd,1}=$	121,96	kN	121,96	kN	121,96	kN
$F_{v,Rd}=$	243,91	kN OK	243,91	kN OK	243,91	kN OK

Resistance of plate

$A=$	1608	mm ²	1128	mm ²	1608	mm ²
$A_{net}=$	1176	mm ²	696	mm ²	1176	mm ²
$N_{pl,Rd}=$	570,84	kN	400,44	kN	570,84	kN
$N_{u,Rd}=$	368,8	kN OK	218,3	kN OK	368,8	kN OK

Table 14.4-1 Joint bracing to the plate

The eccentricity of the stiffener's connection to the column produces the torsional moment in the column. It is necessary to verify the torsional capacity of the of the most stressed column.

$$e = 50 \text{ mm} \text{ — eccentricity of the joint}$$

$$\alpha = 49^\circ$$

$$H = 12 \text{ m} \text{ — length of the column}$$



$$F_y = (N_{Ed,3} - N_{Ed,1}) \cdot \cos(\alpha) = (82,332 - 64,72) \cdot \cos(49) = 11,55 \text{ kN}$$

$$F_z = (N_{Ed,3} + N_{Ed,1}) \cdot \cos(\alpha) - N_{Ed,2} \\ = (-82,332 - 64,72) \cdot \sin(49) + 64,06 = -46,92 \text{ kN}$$

$$M'_x = 11,55 \cdot 0,05 = 0,573 \text{ kNm}$$

HEA 240

$$f_y = 355 \quad \text{MPa}$$

$$A = 7684 \quad \text{mm}^2$$

$$h = 230 \quad \text{mm}$$

$$b = 240 \quad \text{mm}$$

$$t_w = 8 \quad \text{mm}$$

$$t_f = 12 \quad \text{mm}$$

$$I_t = 415519,4015 \quad \text{mm}^4$$

$$I_w = 3,285 \cdot 10^{11} \quad \text{mm}^6$$

$$\omega_{max} = \pm \frac{b \cdot h}{4} = \pm \frac{240 \cdot 230}{4} = \pm 13800 \text{ mm}^2$$

$$B_{Ed} = M'_x \cdot H = 0,573 \cdot 12 = 6,876 \text{ kNm}^2$$

$$B_{Rk} = \frac{I_w}{\omega_{max}} \cdot f_y = \frac{3,285 \cdot 10^{11}}{13800} \cdot 355 = 8450,5 \text{ kNm}^2$$

$$B_{Rk}/B_{Ed} = 0,000814 = 0,0814\%$$

The torsional moment affects the load-bearing capacity of the column to less than 1%, which covers the load bearing capacity reserve (see design of the outer columns on the page 63).

14.4.1. Plate weld to the column

$$a_w = 4 \text{ mm}$$

$$\tau_{\parallel,1} = \frac{F_y}{2 \cdot a_w \cdot L_w} = \frac{11,55 \cdot 10^3}{2 \cdot 4 \cdot 194} = 7,44 \text{ MPa}$$

$$\sqrt{3\tau_{\parallel}^2} = 12,89 \text{ MPa} \leq 435,6 \text{ MPa} = \frac{f_u}{\beta_w \cdot \gamma_{M2}} \\ = \frac{490}{0,9 \cdot 1,25}$$

$$\tau_{\parallel,2} = \frac{F_z}{4 \cdot a_w \cdot L_w} = \frac{46,92 \cdot 10^3}{2 \cdot 4 \cdot 110} = 53,32 \text{ MPa}$$

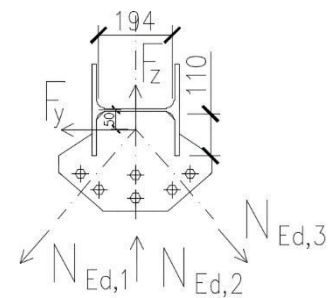



$$\sqrt{3\tau_{\parallel}^2} = 92,35 \text{ MPa} \leq 435,6 \text{ MPa} = \frac{f_u}{\beta_w \cdot \gamma_{M2}} = \frac{490}{0,9 \cdot 1,25}$$

Connection is OK

14.5. Secondary beam to a primary beam (column) connection

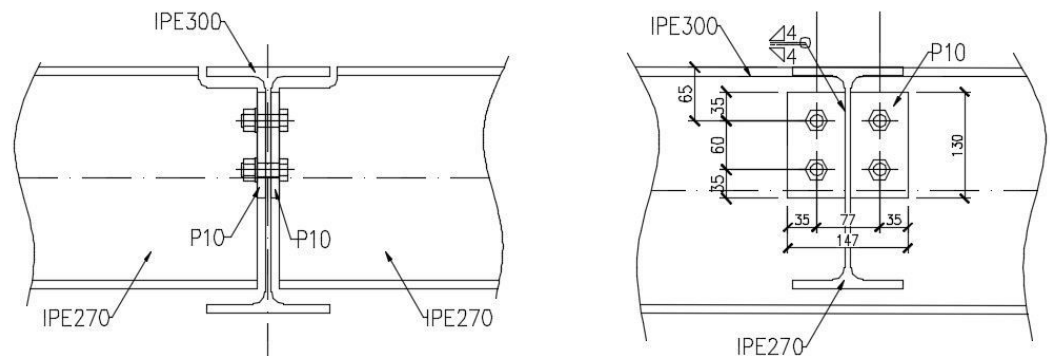

Figure 14.5-1 Sketch of the connection

All connections are made with the end plate and does not transfer the moment. Bolts of quality 8.8 will be used.

$$F_{Ed} = 57,34 \text{ kN} \text{ — see 13.1.4 (page 85)}$$

Weld resistance:

$$\tau_{\parallel} = \frac{F_{Ed}}{n_w \cdot a_w \cdot L_w}$$

$$\sqrt{\sigma_{\perp}^2 + 3(\tau_{\perp} + \tau_{\parallel})^2} \leq 435,556 \text{ MPa} = \frac{f_u}{\beta_w \cdot \gamma_{M2}}$$

Shear resistance:

$$F_{v,Rd,1} = \frac{0,6 \cdot n \cdot A \cdot f_{ub}}{\gamma_{M2}}$$

$n = 2$ —number of the friction planes

Bearing resistance:

$$k_1 = \min\left(2,8 \cdot \frac{e_2}{d_0} - 1,7; 2,5\right)$$

$$\alpha_b = \min\left(\frac{e_1}{3 \cdot d_0}; \frac{p_1}{3d_0} - 0,25; \frac{f_{ub}}{f_u}; 1,0\right)$$



$$F_{b,Rd,1} = \frac{k_1 \cdot \alpha_b \cdot d \cdot t \cdot f_u}{\gamma_{M2}}$$

Plate resistance:

$$N_{pl,Rd} = A \cdot \frac{f_y}{\gamma_{M0}}$$

$$N_{u,Rd} = 0,9A_{net} \cdot \frac{f_u}{\gamma_{M2}}$$

$$V_{Ed,a} = 57,34 \quad \text{kN}$$

$$f_y = 355 \quad \text{MPa}$$

$$f_u = 490 \quad \text{MPa}$$

$$f_u / (\beta_w \cdot \gamma_{M2}) = 435,6 \quad \text{MPa}$$

$$A_a = 130 \quad \text{mm}$$

vertical size of the end plate

$$B_a = 147 \quad \text{mm}$$

horizontal size of the end plate

Welds:

$$L_{a2} = 130 \quad \text{mm}$$

length of vertical welds

$$a_{w1} = 4 \quad \text{mm}$$

thickness of the weld

$$n_1 = 2$$

number of vertical welds

$$\tau_{\parallel,1} = 55,13 \quad \text{MPa}$$

$$\sigma_{\perp} = \tau_{\perp} = 0 \quad \text{MPa}$$

$$\sigma_{\perp} = 95,49 \quad \text{MPa}$$

<435,6 MPa OK

Bolts:

$$t = 8 \quad \text{mm}$$

thickness of the plate

$$d = 16 \quad \text{mm}$$

$$d_0 = 18 \quad \text{mm}$$

$$A = 201,1 \quad \text{mm}^2$$

gross cross-section of the bolt

$$e_1 = 35 \quad \text{mm}$$

$$e_2 = 35 \quad \text{mm}$$

$$p_1 = 60 \quad \text{mm}$$

$$f_{ub} = 800 \quad \text{MPa}$$

ultimate tensile strength of the bolt

$$n = 4$$

number of the bolts

Shear resistance

$$F_{v,Rd,1} = 154,42 \quad \text{kN}$$

$$F_{v,Rd} = 617,7 \quad \text{kN}$$

>(57,34·2)=114,68 kN OK

Bearing resistance

$$K_1 = (\min) \left[\begin{array}{l} 3,74 \\ 2,5 \end{array} \right.$$

$$a_b = (\min) \left[\begin{array}{l} 0,648 \\ 0,861 \\ 1,000 \end{array} \right.$$



$$F_{v,Rd,1} = 81,3 \quad \text{kN}$$

$$F_{v,Rd} = 325,2 \quad \text{kN} \quad >(57,34 \cdot 2) = 114,68 \text{ kN OK}$$

Plate resistance:

$$A = 1176 \quad \text{mm}^2 \quad \text{full section area}$$

$$A_{net} = 888 \quad \text{mm}^2 \quad \text{net section area}$$

$$N_{pl,Rd} = 417,48 \quad \text{kN}$$

$$N_{u,Rd} = 278,5 \quad \text{kN}$$

$$N_{t,Rd} = 278,5 \quad \text{kN} \quad >(57,34 \cdot 2) = 114,68 \text{ kN OK}$$

14.6. Primary beam to a column connection

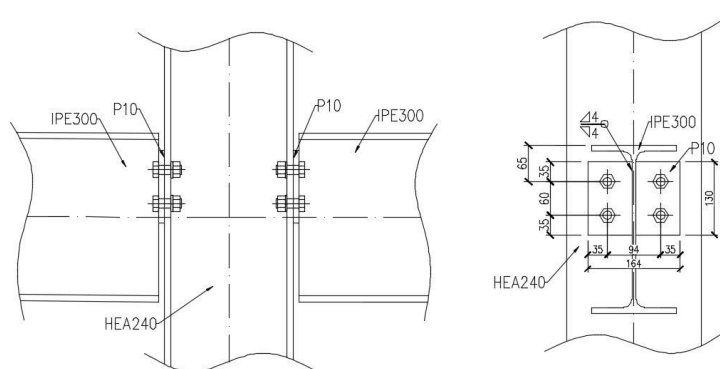

Figure 14.6-1 Scheme of the primary beam connection

All connections are made with the end plate and does not transfer the moment. Bolts of quality 8.8 will be used. The calculation procedure is the same as in the previous chapter.

$$F_{Ed} = 191,83 \text{ kN} \text{ — see 13.1.6 (page 93)}$$

$$V_{Ed} = 191,83 \quad \text{kN}$$

$$f_y = 355 \quad \text{MPa}$$

$$f_u = 490 \quad \text{MPa}$$

$$f_u / (\beta_w \cdot \gamma_{M2}) = 435,6 \quad \text{MPa}$$

$$A_a = 130 \quad \text{mm} \quad \text{vertical size of the end plate}$$

$$B_a = 164 \quad \text{mm} \quad \text{horizontal size of the end plate}$$

Welds:

$$L_{a1} = 130 \quad \text{mm} \quad \text{length of vertical welds}$$

$$a_{w1} = 4 \quad \text{mm} \quad \text{thickness of the weld}$$

$$n_1 = 2 \quad \text{number of vertical welds}$$



$$\begin{aligned}\tau_{\parallel,1} &= 184,45 \text{ MPa} \\ \sigma_{\perp} = \tau_{\perp} &= 0 \text{ MPa} \\ \sigma_{\perp} &= 319,48 \text{ MPa} < 435,6 \text{ MPa OK}\end{aligned}$$

Bolts:

$$\begin{aligned}t &= 10 \text{ mm} && \text{thickness of the plate} \\ d &= 16 \text{ mm} \\ d_0 &= 18 \text{ mm} \\ A &= 201,1 \text{ mm}^2 \\ e_1 &= 35 \text{ mm} \\ e_2 &= 35 \text{ mm} \\ p_1 &= 60 \text{ mm} \\ f_{ub} &= 800 \text{ MPa} \\ n &= 4\end{aligned}$$

Shear resistance

$$\begin{aligned}F_{v,Rd,1} &= 77,21 \text{ kN} \\ F_{v,Rd} &= 308,8 \text{ kN} > 191,83 \text{ kN OK}\end{aligned}$$

Bearing resistance

$$\begin{aligned}K1 = (\min) & \left\{ \begin{array}{l} 3,74 \\ 2,5 \end{array} \right. \\ ab = (\min) & \left\{ \begin{array}{l} 0,648 \\ 0,861 \\ 1,000 \end{array} \right.\end{aligned}$$

$$\begin{aligned}F_{v,Rd,1} &= 101,6 \text{ kN} \\ F_{v,Rd} &= 406,5 \text{ kN} > 191,83 \text{ kN OK}\end{aligned}$$

Plate resistance:

$$\begin{aligned}A &= 1640 \text{ mm}^2 \\ A_{net} &= 1280 \text{ mm}^2 \\ N_{pl,Rd} &= 582,2 \text{ kN} \\ N_{u,Rd} &= 401,4 \text{ kN} \\ N_{t,Rd} &= 401,4 \text{ kN} > 191,83 \text{ kN OK}\end{aligned}$$

14.7. Base plate of inner column

The column plate of inner column are designed as hinged and transfer only normal force. Anchor bolts are designed as chemical anchors 4xM12 (see appendix).

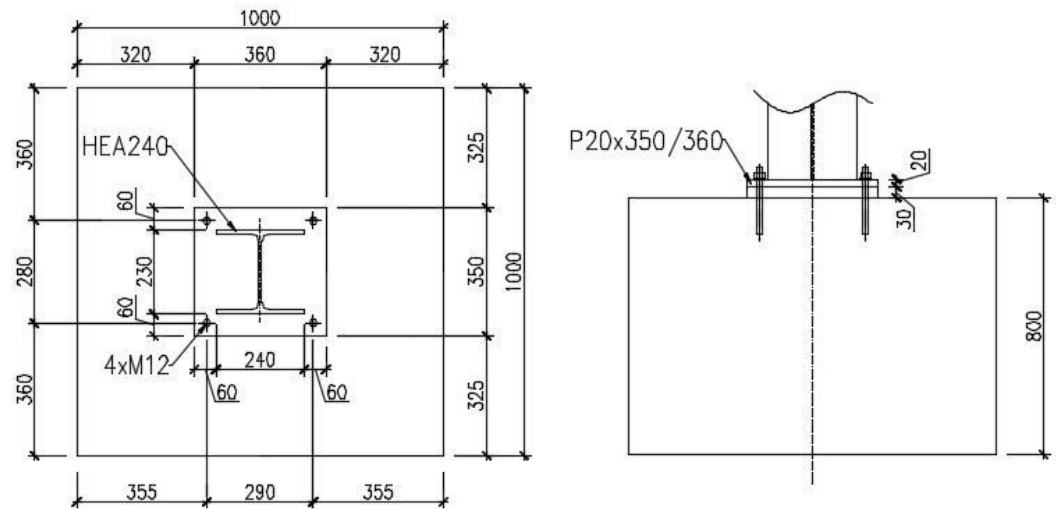

Figure 14.7-1 Sketch of the column foundation (HEA240)

Columns		N_{Ed} [kN]	$V_{ed,z}$ [kN]	$M_{ed,y}$ [kNm]
1) Inner column in hall part (HEA240)	CO 2	-767,756	-0,060	0
	CO 3	43,880	0	0
2) Outer column in hall part (HEA340)	CO2	-468,238	7,273	0
	CO4	42,810	46,743	180,71
3) Inner column in administrative part (HEA240)	CO8	-793,015	0	0
4) Outer column in administrative part (HEA240)	CO2	-571,494	-3,11	2,644

Table 14.7-1 Internal forces in the columns base plate

14.7.1. Pressure load capacity of the base plate

The column foundation will be made of C20/25 grade concrete of dimensions 1000x1000x800 mm.

$$f_{ck} = 20 \text{ MPa}$$

$$a_c = b_c = 1000 \text{ mm}$$

$$h = 800 \text{ mm}$$

$$a_0 = 350 \text{ mm}$$

$$b_0 = 360 \text{ mm}$$

$$t_p = 15 \text{ mm}$$



$$a_1 = \min(3 \cdot a_0; a_0 + h; a_c) = \min(3 \cdot 350; 350 + 800; 1000) \\ = 1000 \text{ mm}$$

$$b_1 = \min(3 \cdot b_0; b_0 + h; b_c) = \min(3 \cdot 360; 360 + 800; 1000) = 1000 \text{ mm}$$

Stress concentration coefficient:

$$k_j = \sqrt{\frac{a_1 \cdot b_1}{a_0 \cdot b_0}} = \sqrt{\frac{1000 \cdot 1000}{350 \cdot 360}} = 2,82$$

Design concrete strength:

$$f_{jd} = \frac{\beta \cdot k_j \cdot f_{ck}}{\gamma_c} = \frac{2}{3} \cdot \frac{2,82 \cdot 20}{1,5} = 25,04 \text{ MPa}$$

Effective width of the base plate:

$$c = t_p \cdot \sqrt{\frac{f_{yd}}{3 \cdot f_{jd}}} = 20 \cdot \sqrt{\frac{355}{3 \cdot 25,04}} = 43,48 \text{ mm}$$

Effective area of the base plate:

$$A_{eff} = 75956 \text{ mm}^2 \text{ — determined graphically}$$

Load capacity of the base plate:

$$N_{Rd} = A_{eff} \cdot f_{jd} = 75956 \cdot 25,04 = 1902,1 \text{ kN} > 793 \text{ kN} = N_{Ed,max}$$

14.7.2. Welds

The column is welded to the plate by the fillet weld.

$$a_w = 4 \text{ mm}$$

$$L_w = P = 1368,95 \text{ mm — perimeter of the HEA 240 cross-section}$$

$$\sigma_{\perp} = \tau_{\perp} = \frac{N_{Ed}}{\sqrt{2} \cdot a_w \cdot L_w} = \frac{43,880 \cdot 10^3}{\sqrt{2} \cdot 4 \cdot 1368,95} = 5,67 \text{ MPa}$$

$$\sigma_{\perp} = 5,67 \text{ MPa} \leq 392 \text{ MPa} = \frac{f_u}{\gamma_{M2}} = \frac{490}{1,25}$$

$$\sqrt{\sigma_{\perp}^2 + 3(\tau_{\perp} + \tau_{\parallel})^2} = 11,34 \text{ MPa} \leq 435,556 \text{ MPa} = \frac{f_u}{\beta_w \cdot \gamma_{M2}} \\ = \frac{490}{0,9 \cdot 1,25}$$

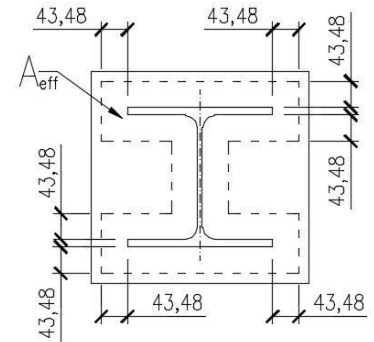

Figure 14.7-2 Effective area of the base plate



14.7.3. Tensile and shear resistance of the anchors

The anchoring of the columns to the foundation structures is by means of chemical anchors 4xM12 (for HEA240) and 4xM20 (for HEA340) HILTI HIT-HY 200 HIT-V 8.8. The design of HITLI anchors will be done in the software Profis Anchor (see attachment).

14.8. Base plate of outer column (with bracing)

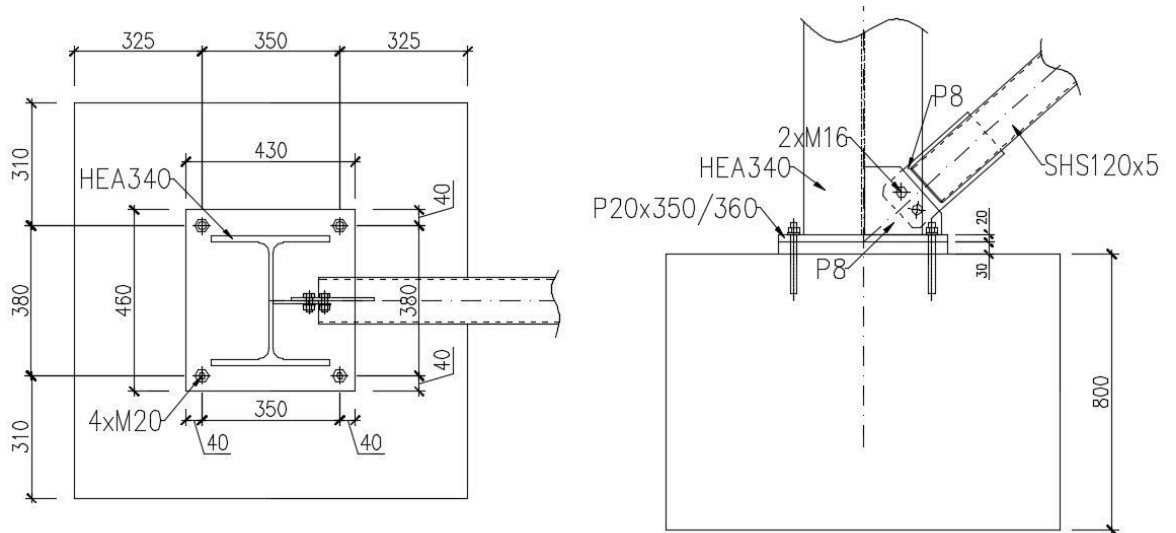

Figure 14.8-1 Scheme of the base plate

The foot of the column, which is a part of the stiffener, must transfer both normal and shear force. The concrete foundation is considered the same dimension as for the inner column. The dimensions of the plate are shown in the figure. Compared to the base plate of the inner column, the joint plate will be welded to join the brace. The force in the foot can be found in the Table 14.7-1 (page 124).

HEA 340

$f_y =$	355	MPa
$A =$	13347	mm ²
$h =$	330	mm
$b =$	300	mm
$t_w =$	10	mm
$t_f =$	17	mm

Concrete	$f_{ck} =$	20	MPa
C20/25	$a_c =$	1000	mm
	$b_c =$	1000	mm

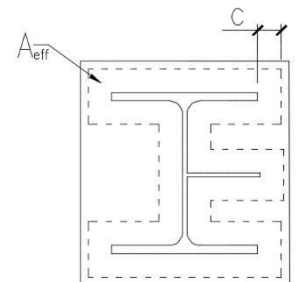

Figure 14.8-2 Effective area of the base plate



	h=	800	mm	
Plate	a ₀ =	430	mm	
	b ₀ =	460	mm	
	t=	20	mm	
	a ₁ =	1000	mm	
	b ₁ =	1000	mm	
	k _j =	2,25		stress concentration factor
	f _{jd} =	19,99	MPa	design concrete strength
	c=	48,66	mm	effective width of the base plate
	A _{eff} =	127574	mm ²	effective area of the base plate
	N _{Rd} =	2549,74	kN	> 468,238 kN OK

The shear and tensile forces are transmitted by chemical anchors, calculated in the HILTI Profis anchor software.

The column is welded to the plate by the around fillet weld.

$$a_w = 4 \text{ mm}$$

$$N_{Ed} = 42,81 \text{ kN} \text{ — tensile force in the base plate}$$

$$V_{Ed} = 46,743 \text{ kN} \text{ — shear forces in the base plate}$$

$$P = 1794,6 \text{ mm} \text{ — perimeter of the HEA 340 cross-section}$$

$$L_w = 300 \text{ mm} \text{ — length of the weld to transfer shear forces to plate}$$

$$\sigma_{\perp} = \tau_{\perp} = \frac{1}{\sqrt{2}} \cdot \frac{N_{Ed}}{a_w \cdot P} = \frac{1}{\sqrt{2}} \cdot \frac{42,81 \cdot 10^3}{4 \cdot 1794,5} = 4,22 \text{ MPa} \leq \mathbf{392 \text{ MPa}} = \frac{f_u}{\gamma_{M2}}$$
$$= \frac{490}{1,25}$$

$$\tau_{\parallel} = \frac{V_{Ed}}{2 \cdot a_w \cdot L_w} = \frac{46,743 \cdot 10^3}{2 \cdot 4 \cdot 243} = 24,0 \text{ MPa}$$

$$\sqrt{\sigma_{\perp}^2 + 3(\tau_{\perp} + \tau_{\parallel})^2} = \sqrt{4,22^2 + 3(4,22 + 24,0)^2} = \mathbf{49,1 \text{ MPa}}$$

$$\leq \mathbf{435,556 \text{ MPa}} = \frac{f_u}{\beta_w \cdot \gamma_{M2}} = \frac{490}{0,9 \cdot 1,25}$$



14.8.1. Bracing to base plate connection

The calculation procedure is similar to the chapter 14.1.1.

	$N_{Ed,max,a} =$	83,04	kN
	$V_{ed,a} =$	0	kN
	$M_{ed,a} =$	0	kNm
	$\alpha =$	41,9	°
	$F_a =$	83,04	kN
	$f_y =$	355	MPa
	$f_u =$	490	MPa
	$f_u / (\beta_w \cdot \gamma_{M2}) =$	435,6	MPa
Plate geometry	$A_a =$	300	mm
	$B_a =$	140	mm
Welds	$L_{a1} =$	200	mm
	$a_{w1} =$	3	mm
	$n_1 =$	4	
	$\tau_{ ,1} =$	34,5992	MPa

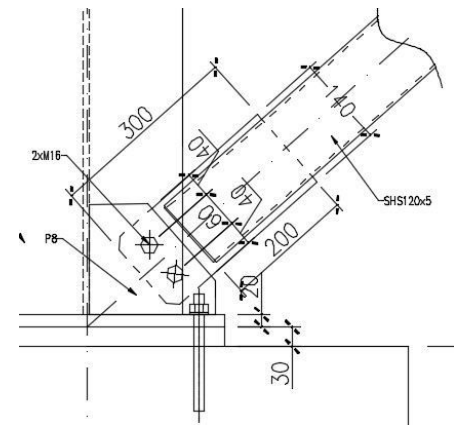

Figure 14.8-3 Scheme of the bracing connection

$$\sqrt{\sigma_{\perp}^2 + 3(\tau_{\perp} + \tau_{||})^2} = 59,93 \text{ MPa} \leq 435,6 \text{ MPa} = \frac{f_u}{\beta_w \cdot \gamma_{M2}} = \frac{490}{0,9 \cdot 1,25}$$

Bolts

	$t =$	8	mm
	$d =$	16	mm
	$d_0 =$	18	mm
	$A =$	201,1	mm ²
	$e_1 =$	35	mm
	$e_2 =$	35	mm
	$p_1 =$	60	mm
	$f_{ub} =$	800	MPa
	$n =$	2	
	Shear resistance		
	$F_{v,Rd,1} =$	77,21	kN
	$F_{v,Rd} =$	154,4	kN
			> 83,038 kN OK
	Bearing resistance		
	$K_1 = (\min)$	3,74	
		2,5	
	$a_b = (\min)$	0,648	
		0,861	
		1,633	
		1	
	$F_{v,Rd,1} =$	81,3037	kN
	$F_{v,Rd} =$	162,607	kN
			> 83,038 kN OK
	Resistance of plate		
	$A =$	1120	mm ²
	$A_{net} =$	832	mm ²



$$\begin{aligned} N_{pl,Rd} &= 397,6 \text{ kN} \\ N_{u,Rd} &= 260,9 \text{ kN} \\ N_{t,Rd} &= 260,915 \text{ kN} > 83,038 \text{ kN OK} \end{aligned}$$

$$F_y = N_{Ed} \cdot \cos(\alpha) = 83,04 \cdot \cos(41,9) = 61,81 \text{ kN}$$

$$F_z = N_{Ed} \cdot \sin(\alpha) = 83,04 \cdot \sin(41,9) = 55,45 \text{ kN}$$

- Welds resistance:

$$L_{a1} = 200 \text{ mm} \text{ — length of the horizontal welds}$$

$$L_{a2} = 170 \text{ mm} \text{ — length of the vertical welds}$$

$$a_{a1} = 4 \text{ mm} \text{ — thickness of the weld}$$

Stress in horizontal weld:

$$\tau_{\parallel,1} = \frac{F_y}{2 \cdot a_w \cdot L_{a1}} = \frac{61,81 \cdot 10^3}{2 \cdot 4 \cdot 200} = 38,6 \text{ MPa}$$

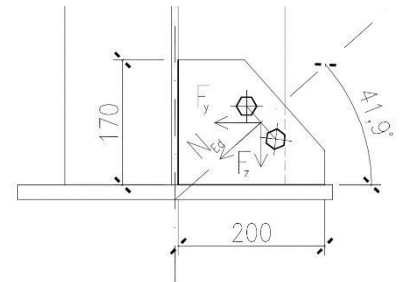

Figure 14.8-4 Scheme of the welds

$$\sqrt{3\tau_{\parallel,1}^2} = \sqrt{3 \cdot 38,6^2} = 66,86 \text{ MPa} < 435,6 \text{ MPa} = \frac{f_u}{\beta_w \cdot \gamma_{M2}} = \frac{490}{0,9 \cdot 1,25}$$

Stress in horizontal weld:

$$\tau_{\parallel,2} = \frac{F_z}{2 \cdot a_w \cdot L_{a1}} = \frac{55,45 \cdot 10^3}{2 \cdot 4 \cdot 170} = 40,8 \text{ MPa}$$

$$\sqrt{3\tau_{\parallel,1}^2} = \sqrt{3 \cdot 40,8^2} = 70,7 \text{ MPa} < 435,6 \text{ MPa} = \frac{f_u}{\beta_w \cdot \gamma_{M2}} = \frac{490}{0,9 \cdot 1,25}$$

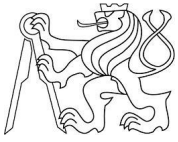

Part C

In this chapter, trusses from the previous chapter are designed by using steel grades S460 and S690. For each variation, a pre-estimated material cost (based on their self-weights) will be made. Variants will be compared and evaluated for the cheapest option.



15. High strength steel truss design

In this chapter the same girder, as in previous part, will be designed using steels S460 and S690. The cheapest option for the NEXEN TIRE project will be evaluated.

There are some parameters that can be observed to design a high-strength steel structure (from RUUKKI steel supplier):

- 1) Only closed cold-formed cross-sections and sheets;
- 2) The total weight of all profiles of one thickness must be at least 15 t;
- 3) The maximum dimension of the profile is SHS 200x12.5 mm

15.1. Truss members design S460

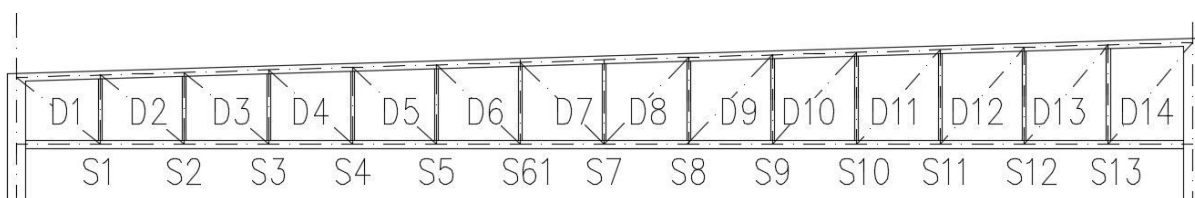

Table 15.1-1 Diagonal and vertical members' numbering S460

15.1.1. Tensile members profile design

$$f_y = 460 \text{ MPa}$$

$$E = 210 \text{ GPa}$$

$$A_{min,req} = \frac{N_{Ed}}{f_y}$$

	Member	length	Forces	Strength	$A_{min,req}$	Profile	A	$N_{t,Rd}$	Ned < NRd	
	No.	L [m]	Ned	f_y [MPa]	[mm]	SHS	[mm]	[kN]		
Lower chord	674	28,00	1251,88	460	2721,48	150x5	2870	1320,2	0,95	OK
Diagonal D1	205	2,551	516,41	460	1122,63	80x4	1200	552	0,94	OK
Diagonal D2	373	2,588	406,27	460	883,20	70x4	1040	478,4	0,85	OK
Diagonal D3	245	2,627	311,20	460	676,52	50x4	719	330,74	0,94	OK
Diagonal D4	319	2,667	214,22	460	465,69	50x4	719	330,74	0,65	OK
Diagonal D5	402	2,707	133,37	460	289,93	50x4	719	330,74	0,40	OK
Diagonal D6	599	2,748	54,31	460	118,06	50x4	719	330,74	0,16	OK
Diagonal D7	1099	2,790	1,65	460	3,58	50x4	719	330,74	0,00	OK
Diagonal D8	772	2,876	90,60	460	196,95	50x4	719	330,74	0,27	OK
Diagonal D9	1606	2,920	152,44	460	331,38	50x4	719	330,74	0,46	OK



Diagonal D10	1170	2,964	216,98	460	471,70	50x4	719	330,74	0,66	OK
Diagonal D11	1108	3,009	274,99	460	597,80	50x4	719	330,74	0,83	OK
Diagonal D12	2227	3,055	333,62	460	725,26	60x4	879	404,34	0,83	OK
Diagonal D13	1370	3,101	384,44	460	835,73	60x4	879	404,34	0,95	OK
Diagonal D14	1481	3,147	441,67	460	960,16	70x4	1040	478,4	0,92	OK

15.1.2. Pressured members design

The following formulas were used for the calculation, the results will be in the following table:

$$f_y = 460 \text{ MPa}$$

$$E = 210 \text{ GPa}$$

$$L_{cr} = 0,9L \text{ — for hollow-section chords and vertical members}$$

$$\lambda_1 = \pi \cdot \sqrt{\frac{E}{f_y}} = \pi \cdot \sqrt{\frac{210000}{460}} = 67,12$$

$$\lambda = \frac{L_{cr}}{i}$$

$$\lambda_{rel} = \frac{\lambda}{\lambda_1}$$

$$\phi = 0,5 \cdot [1 + \alpha(\bar{\lambda} - 0,2) + \bar{\lambda}^2]$$

$$\alpha = 0,49 \text{ — buckling curve C for cold formed hollow-section}$$

$$\chi = \frac{1}{\phi + \sqrt{\phi^2 - \bar{\lambda}^2}}$$

$$N_{b,Rd} = \chi \cdot A \cdot \frac{f_y}{\gamma_{M1}}$$

	Mem ber	Forces [kN]	lengt h	L_{cr}	Profile	A	λ_{rel}	λ	χ	f_y	$N_{b,Rd}$	N_{Ed}/N_{Rd}	
	No.	N_{Ed}	L [m]										
S1	100	-319,35	1,64	1,478	80x4	1200	0,712	47,8	0,717	460	395,8	0,807	OK
D1	205	-46,75	2,55	2,296	80x4	1200	1,107	74,3	0,481	460	265,3	0,176	OK
S2	221	-258,93	1,70	1,533	60x6	1260	1,047	70,3	0,513	460	297,3	0,871	OK
D3	245	-23,48	2,63	2,364	50x4	719	1,894	127,1	0,215	460	71,22	0,330	OK
S3	284	-203,93	1,76	1,588	60x4	879	1,042	69,9	0,516	460	208,6	0,977	OK
D4	319	-18,70	2,67	2,400	50x4	719	1,923	129,0	0,210	460	69,42	0,269	OK
D2	373	-33,95	2,59	2,329	70x4	1040	1,295	86,9	0,391	460	187,1	0,182	OK



Diploma thesis
Possibilities of using HSS in truss beams – a parametric study
Static calculation

D5	402	-10,06	2,71	2,436	50x4	719	1,951	131,0	0,205	460	67,68	0,149	OK
S5	494	-93,33	1,89	1,697	50x4	719	1,359	91,2	0,365	460	120,7	0,773	OK
S4	539	-144,99	1,82	1,642	60x4	879	1,077	72,3	0,496	460	200,7	0,722	OK
D6	599	-6,80	2,75	2,473	50x4	719	1,981	133,0	0,199	460	65,96	0,103	OK
S6	654	-41,77	1,95	1,751	50x4	719	1,402	94,1	0,348	460	115,2	0,362	OK
D8	772	-7,82	2,88	2,588	50x4	719	2,073	139,2	0,184	460	60,98	0,128	OK
S7	823	-56,98	2,01	1,805	50x4	719	1,446	97,1	0,333	460	110	0,518	OK
S8	830	-114,72	2,07	1,860	60x4	879	1,221	82,0	0,424	460	171,4	0,669	OK
S10	1064	-206,85	2,19	1,969	70x4	1040	1,095	73,5	0,487	460	233	0,888	OK
D7	1099	-15,49	2,79	2,511	50x4	719	2,011	135,0	0,194	460	64,27	0,241	OK
D11	1108	-22,06	3,01	2,708	50x4	719	2,169	145,6	0,170	460	56,36	0,391	OK
D10	1170	-15,22	2,96	2,668	50x4	719	2,137	143,4	0,175	460	57,87	0,263	OK
S13	1316	-338,58	2,37	2,132	90x4	1360	0,908	60,9	0,595	460	372,4	0,909	OK
S11	1345	-252,39	2,25	2,023	80x4	1200	0,975	65,5	0,554	460	306	0,825	OK
D13	1370	-33,59	3,10	2,791	60x4	879	1,832	122,9	0,228	460	92,1	0,365	OK
D14	1481	-40,92	3,15	2,832	70x4	1040	1,574	105,7	0,292	460	139,5	0,293	OK
S9	1604	-161,92	2,13	1,914	60x4	879	1,256	84,3	0,408	460	164,9	0,982	OK
D9	1606	-15,14	2,92	2,628	50x4	719	2,105	141,3	0,180	460	59,4	0,255	OK
S12	1877	-293,90	2,31	2,078	80x4	1200	1,002	67,3	0,539	460	297,4	0,988	OK
D12	2227	-27,11	3,06	2,750	60x4	879	1,804	121,1	0,234	460	94,43	0,287	OK
Upper chord (y direction)	594	-1319,67	2,00	1,801	160x10	5890	0,441	29,6	0,876	460	2373	0,556	OK
Upper chord (z dir. in the middle)	594	-1319,67	4,00	3,602	160x10	5890	0,881	59,1	0,611	460	1657	0,797	OK
Upper chord (z dir. at the edge)	594	-934,10	6,00	5,403	160x10	5890	1,322	88,7	0,380	460	1029	0,908	OK
Lower chord (y direction)	674	-106,88	2,00	1,800	150x5	2870	0,455	30,5	0,868	460	1146	0,093	OK
Lower chord (z dir. in the middle)	674	-106,88	8,00	7,200	150x5	2870	1,818	122,0	0,231	460	304,5	0,351	OK
Lower chord (z dir. At the edge)	674	-94,61	10,0	9,000	150x5	2870	2,273	152,5	0,157	460	207,3	0,456	OK

Table 15.1-2 Pressured members design

15.1.1. Interaction factors

Internal forces in the upper chord in the middle of the truss:

$$N_{Ed} = 1319,67 \text{ kN}$$

$$M_{Ed,y} = 15,29 \text{ kNm}$$



Internal forces are determined by a nonlinear calculation performed in the Dlubal software (see Appendix).

SHS160x10:

$$f_y = 460 \text{ MPa}$$

$$E = 210 \text{ GPa}$$

$$h = b = 160 \text{ mm}$$

$$A = 5890 \text{ mm}^2$$

$$W_{pl,y} = W_{pl,z} = 329 \cdot 10^3 \text{ mm}^3$$

$$I_y = I_z = 21,86 \cdot 10^6 \text{ mm}^4$$

$$i = 60,9 \text{ mm}$$

For the determination of the interaction factors k_{ij} , Appendix B will be used.

$$M_h = 4,462 \text{ kNm}$$

$$M_s = 15,290 \text{ kNm}$$

$$\psi \cdot M_h = 1,036 \text{ kNm}$$

$$\alpha_h = M_h/M_s = 0,29$$

$$\psi = 0,23$$

$$C_{my} = 0,95 + 0,05 \cdot \alpha_h = 0,95 + 0,05 \cdot 0,14 = 0,957 \text{ — (see 9.6.3)}$$

$$\begin{aligned} k_{yy} &= C_{my} \left(1 + (\bar{\lambda}_y - 0,2) \frac{N_{Ed}}{\chi_y \cdot A \cdot f_y / \gamma_{M0}} \right) \\ &= 0,957 \left(1 + (0,441 - 0,2) \frac{1319,67 \cdot 10^3}{0,876 \cdot 5890 \cdot 460/1} \right) = 1,094 \end{aligned}$$

$$\begin{aligned} k_{yy} &\leq C_{my} \left(1 + 0,8 \frac{N_{Ed}}{\chi_y \cdot N_{Rk} / \gamma_{M1}} \right) = 0,965 \left(1 + 0,8 \frac{1319,67 \cdot 10^3}{0,876 \cdot 5890 \cdot \frac{460}{1}} \right) \\ &= 1,394 \end{aligned}$$

$$\mathbf{k_{yy} = 1,094}$$

$$\mathbf{k_{zy} = 0,6 \cdot k_{yy} = 0,656}$$



ULS verification:

$$\begin{aligned} & \frac{N_{Ed}}{\chi_y \cdot N_{Rk}/\gamma_{M1}} + k_{yy} \frac{M_{y,Ed}}{\chi_{LT} \cdot M_{y,Rk}/\gamma_{M1}} \\ &= \frac{1319,67 \cdot 10^3}{0,876 \cdot 2709 \cdot 10^3/1} + 1,094 \frac{15,29 \cdot 10^6}{1,0 \cdot 151,34 \cdot 10^6/1} \\ &= 0,56 + 0,11 = \mathbf{0,667} \leq \mathbf{1} \end{aligned}$$

$$\begin{aligned} & \frac{N_{Ed}}{\chi_z \cdot N_{Rk}/\gamma_{M1}} + k_{zy} \frac{M_{y,Ed}}{\chi_{LT} \cdot M_{y,Rk}} \\ &= \frac{1319,67 \cdot 10^3}{0,611 \cdot 2709 \cdot 10^3/1} + 0,656 \frac{15,29 \cdot 10^6}{1,0 \cdot 151,34 \cdot 10^6/1} \\ &= \mathbf{0,80} + \mathbf{0,07} = \mathbf{0,87} \leq \mathbf{1} \end{aligned}$$

OK

Buckling in z-direction (in the edge of the truss):

$$N_{Ed} = -934,10 \text{ kN}$$

$$M_{Ed,y} = 13,631 \text{ kNm}$$

$$M_h = 1,907 \text{ kNm}$$

$$M_s = 13,631 \text{ kNm}$$

$$\psi \cdot M_h = -0,748 \text{ kNm}$$

$$\alpha_h = M_h/M_s = 0,14$$

$$\psi = -0,39$$

$$C_{my} = 0,95 + 0,05 \cdot \alpha_h = 0,95 + 0,05 \cdot 0,14 = 0,957$$

$$\begin{aligned} k_{yy} &= C_{my} \left(1 + (\bar{\lambda}_y - 0,2) \frac{N_{Ed}}{\chi_y \cdot A \cdot f_y/\gamma_{M0}} \right) \\ &= 0,957 \left(1 + (0,441 - 0,2) \frac{934,1 \cdot 10^3}{0,876 \cdot 5890 \cdot 460/1} \right) = 1,048 \end{aligned}$$

$$\begin{aligned} k_{yy} &\leq C_{my} \left(1 + 0,8 \frac{N_{Ed}}{\chi_y \cdot N_{Rk}/\gamma_{M1}} \right) \\ &= 0,957 \left(1 + 0,8 \frac{934,1 \cdot 10^3}{0,876 \cdot 5890 \cdot 460/1} \right) = 1,258 \end{aligned}$$

$$\mathbf{k_{yy} = 1,048}$$

$$\mathbf{k_{zy} = 0,6 \cdot k_{yy} = 0,629}$$



ULS verification:

$$\begin{aligned} & \frac{N_{Ed}}{\chi_y \cdot N_{Rk}/\gamma_{M1}} + k_{yy} \frac{M_{y,Ed}}{\chi_{LT} \cdot M_{y,Rk}/\gamma_{M1}} \\ &= \frac{934,1 \cdot 10^3}{0,876 \cdot 2709 \cdot 10^3/1} + 1,048 \frac{13,63 \cdot 10^6}{1,0 \cdot 151,34 \cdot 10^6/1} \\ &= 0,466 + 0,11 = \mathbf{0,579} \leq \mathbf{1} \end{aligned}$$

$$\begin{aligned} & \frac{N_{Ed}}{\chi_z \cdot N_{Rk}/\gamma_{M1}} + k_{zy} \frac{M_{y,Ed}}{\chi_{LT} \cdot M_{y,Rk}} \\ &= \frac{1319,67 \cdot 10^3}{0,380 \cdot 2709 \cdot 10^3/1} + 0,629 \frac{15,29 \cdot 10^6}{1,0 \cdot 151,34 \cdot 10^6/1} \\ &= \mathbf{0,91} + \mathbf{0,06} = \mathbf{0,96} \leq \mathbf{1} \end{aligned}$$

OK

15.1.2. Joints

A detailed procedure for verifying the capacities of the joints is in Chapter 14.2 (page 109). Internal forces are shown on the Figure 14.2-2 (page 110).

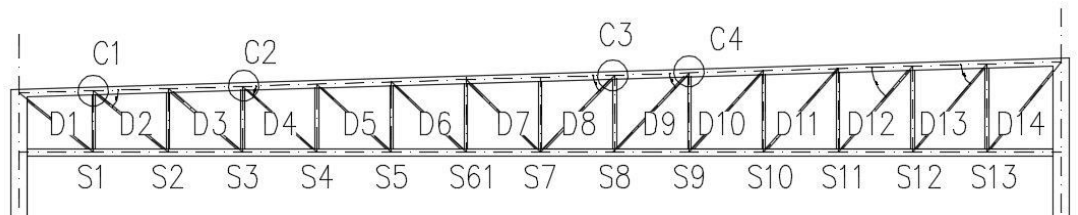

Figure 15.1-1 Members and joints numbering for verification

Upper chord

SHS 160x10

$A_0=$	5890	mm ²
$f_{y0}=$	460	MPa
$f_{u0}=$	550	MPa
$b_0=$	160	mm
$t_0=$	10	mm
$b_0/t_0=$	20	OK
$\gamma=$	16	
$\beta_w=$	1,0	
$f_u/(\beta_w \cdot \gamma_{M2})=$	440	MPa
$f_u/1,25=$	440	MPa

Joint	C1	C2	C3	C4
SHS1=	80x4	60x4	60x4	60x4
SHS2=	70x4	50x4	50x4	50x4



Diploma thesis
Possibilities of using HSS in truss beams – a parametric study
Static calculation

	$b_1=$	80 mm	60 mm	60 mm	60 mm
	$t_1=$	4 mm	4 mm	4 mm	4 mm
	$f_{y1}=$	460 MPa	460 MPa	460 MPa	460 MPa
	$b_2=$	70 mm	50 mm	50 mm	50 mm
	$t_2=$	5 mm	4 mm	4 mm	4 mm
	$f_{y2}=$	460 MPa	460 MPa	460 MPa	460 MPa
	$N_{Ed,1} =$	380,454 kN	933,5 kN	1308,4 kN	1245,5 kN
	$N_{Ed,2} =$	695,458 kN	1180 kN	1247 kN	1142,64 kN
	$N_{Ed,3} =$	319,146 kN	203,7 kN	114,287 kN	161,6 kN
	$N_{Ed,4} =$	406,392 kN	214,4 kN	90,57 kN	152,4 kN
	$\theta_1=$	88,3 °	88,3 °	91,7 °	91,7 °
	$\theta_2=$	41,13 °	43,14 °	44,2 °	45,03 °
	$g=$	10,9 mm	15,7 mm	9,0 mm	14,3 mm
	$b_1/b_0=$	0,533 OK	0,400 OK	0,400 OK	0,400 OK
	$b_2/b_0=$	0,467 OK	0,333 NO	0,333 NO	0,333 NO
Range of validity:	$b_1/t_1=$	20 OK	15 OK	15 OK	15 OK
	$b_2/t_2=$	14 OK	12,5 OK	12,5 OK	12,5 OK
	$t_1+t_2 =$	9 OK	8 OK	8 OK	8 OK
	$\sigma_{1,Ed}$ [MPa]	58,803	144,281	202,226	192,504
	$\sigma_{2,Ed}$ [MPa]	107,490	182,380	192,736	176,606
	$n=$	0,156	0,264	0,279	0,256
	$\beta=$	0,375	0,275	0,275	0,275
	$kn=$	1,000	1,000	1,000	1,000
	b_{eff1} [mm]	133,98	100,49	100,49	100,49
	b_{eff2} [mm]	93,79	83,74	83,74	83,74
Chord face failure	$N_{1,Rd}$ [N]	1 563 932 OK	1 146 883 OK	1 146 883 OK	1 146 883 OK
	$N_{2,Rd}$ [N]	1 680 497 OK	1 185 481 OK	1 162 726 OK	1 145 779 OK
Chord shear	$N_{i,Rd}$ [N]	1 434 770 OK	1 434 770 OK	1 434 770 OK	1 434 770 OK
	$N_{i,Rd}$ [N]	2 180 304 OK	2 097 357 OK	2 057 100 OK	2 027 116 OK
Vertical member failure	$N_{i,Rd}$ [N]	658 688 OK	486 656 OK	486 656 OK	486 656 OK
Diagonal member failure	$N_{i,Rd}$ [N]	652 712 OK	400 640 OK	400 640 OK	400 640 OK
Punching shear	$N_{1,Rd}$ [N]	1 454 237 OK	1 282 064 OK	1 282 064 OK	1 282 064 OK
	$N_{2,Rd}$ [N]	2 462 584 OK	2 060 606 OK	1 994 106 OK	1 945 264 OK
Welds	$a_1=$	4 mm	3 mm	3 mm	3 mm
	$L_{w1} =$	320 mm	240 mm	240 mm	240 mm
	$\sigma_{\perp 3}=\tau_{\parallel 3}$ [MPa] =	176,30 OK	200,05 OK	112,24 OK	158,71 OK
	σ_3 [MPa]=	305 OK	347 OK	194 OK	275 OK
	$F_{x,3} =$	306,1 kN	156,4 kN	64,9 kN	107,7 kN



$F_{y,3} =$	267,3 kN	146,6 kN	63,1 kN	107,8 kN
$a_4 =$	6 mm	5 mm	3 mm	3 mm
$L_{w4} =$	353 mm	246 mm	243 mm	241 mm
$\sigma_{\perp 4} = \tau_{\perp 4}$ [MPa] =	103,78 OK	93,33 OK	63,90 OK	105,12 OK
$\tau_{\parallel 4} =$	146,77 MPa	132,00 MPa	90,37 MPa	148,67 MPa
σ_4 [MPa] =	434 OK	390 OK	267 OK	440 OK

Table 15.1-3 Joints' design

Connections C3 and C4 do not match the range of validity. The load bearing capacity has a reserve. As verified in joint design for truss S355 (see page 109 and appendix), when joint load capacity has a reserve this condition is neglected.

15.2. Truss members design S690

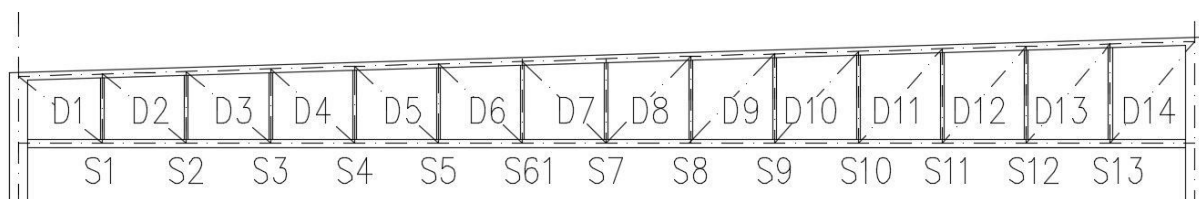

Table 15.2-1 Diagonal and vertical members' numbering S690

15.2.1. Tensile members profile design

The smallest profile will be SHS50x4 due to the validity range for connection design according to Eurocode EN 1993-1-8 [5].

$$f_y = 690 \text{ MPa}$$

$$E = 210 \text{ GPa}$$

$$A_{min,req} = \frac{N_{Ed}}{f_y}$$

	Member	length	Forces	Strength	$A_{min,req}$	Profile	A	$N_{t,Rd}$	Ned < NRd	
	No.	L [m]	Ned [kN]	f_y [MPa]	[mm]	SHS	[mm]	[kN]		
Lower chord	674	28,00	1251,88	690	1814,32	120x5	2270	1566,3	0,80	OK
Diagonal D1	205	2,55	516,41	690	748,42	60x4	879	606,51	0,85	OK
Diagonal D2	373	2,59	406,27	690	588,80	50x4	719	496,11	0,82	OK
Diagonal D3	245	2,63	311,20	690	451,01	50x4	719	496,11	0,63	OK
Diagonal D4	319	2,67	214,22	690	310,46	50x4	719	496,11	0,43	OK
Diagonal D5	402	2,75	133,37	690	193,29	50x4	719	496,11	0,27	OK



Diagonal D6	599	2,88	54,31	690	78,71	50x4	719	496,11	0,11	OK
Diagonal D7	1099	2,71	1,65	690	2,39	50x4	719	496,11	0,00	OK
Diagonal D8	772	3,01	90,60	690	131,30	50x4	719	496,11	0,18	OK
Diagonal D9	1606	3,10	152,44	690	220,92	50x4	719	496,11	0,31	OK
Diagonal D10	1170	3,15	216,98	690	314,47	50x4	719	496,11	0,44	OK
Diagonal D11	1108	2,96	274,99	690	398,53	50x4	719	496,11	0,55	OK
Diagonal D12	2227	2,92	333,62	690	483,51	50x4	719	496,11	0,67	OK
Diagonal D13	1370	3,06	384,44	690	557,16	50x4	719	496,11	0,77	OK
Diagonal D14	1481	3,06	441,67	690	640,10	50x4	719	496,11	0,89	OK

Figure 15.2-1 Tensile members profile design

15.2.2. Pressed truss members design

The following formulas were used for the calculation, the results will be in the following table :

$$f_y = 690 \text{ MPa}$$

$$E = 210 \text{ GPa}$$

$$L_{cr} = 0,9L \text{ — for hollow-section chords and vertical members}$$

$$\lambda_1 = \pi \cdot \sqrt{\frac{E}{f_y}} = \pi \cdot \sqrt{\frac{210000}{690}} = 54,81$$

$$\lambda = \frac{L_{cr}}{i}$$

$$\lambda_{rel} = \frac{\lambda}{\lambda_1}$$

$$\phi = 0,5 \cdot [1 + \alpha(\bar{\lambda} - 0,2) + \bar{\lambda}^2]$$

$$\alpha = 0,49 \text{ — buckling curve C for cold formed hollow-section}$$

$$\chi = \frac{1}{\phi + \sqrt{\phi^2 - \bar{\lambda}^2}}$$

$$N_{b,Rd} = \chi \cdot A \cdot \frac{f_y}{\gamma_{M1}}$$

	Member	Forces [kN]	length	L _{cr}	Profile	A	λ _{rel}	λ	χ	f _y	N _{b,Rd}	Ned/NRd	
	No.	Ned	L [m]	[m]	SHS	[mm]	[-]	[-]	[-]	[MPa]	[kN]		
S1	100	-319,35	1,64	1,478	70x4	1040	1,006	55,1	0,536	690	385	0,830	OK
D1	205	-46,75	2,55	2,296	60x4	879	1,845	101,1	0,225	690	136	0,343	OK
S2	221	-258,93	1,70	1,533	70x4	1040	1,043	57,2	0,515	690	370	0,700	OK



Diploma thesis
Possibilities of using HSS in truss beams – a parametric study
Static calculation

D3	245	-23,48	2,63	2,364	50x4	719	2,319	127,1	0,151	690	75,1	0,313	OK
S3	284	-203,93	1,76	1,588	60x4	879	1,276	69,9	0,399	690	242	0,843	OK
D4	319	-18,70	2,67	2,400	50x4	719	2,355	129,0	0,147	690	73,1	0,256	OK
D2	373	-33,95	2,59	2,329	50x4	719	2,285	125,2	0,156	690	77,2	0,440	OK
D5	402	-10,06	2,71	2,436	50x4	719	2,390	131,0	0,144	690	71,2	0,141	OK
S5	494	-93,33	1,89	1,697	50x4	719	1,664	91,2	0,267	690	132	0,705	OK
S4	539	-144,99	1,82	1,642	60x4	879	1,319	72,3	0,381	690	231	0,628	OK
D6	599	-6,80	2,75	2,473	50x4	719	2,426	133,0	0,140	690	69,3	0,098	OK
S6	654	-41,77	1,95	1,751	50x4	719	1,717	94,1	0,254	690	126	0,332	OK
D8	772	-7,82	2,88	2,588	50x4	719	2,539	139,2	0,129	690	63,9	0,122	OK
S7	823	-56,98	2,01	1,805	50x4	719	1,771	97,1	0,241	690	120	0,477	OK
S8	830	-114,72	2,07	1,860	60x4	879	1,495	82,0	0,316	690	192	0,598	OK
S10	1064	-206,85	2,19	1,969	70x4	1040	1,341	73,5	0,372	690	267	0,775	OK
D7	1099	-15,49	2,79	2,511	50x4	719	2,463	135,0	0,136	690	67,5	0,229	OK
D11	1108	-22,06	3,01	2,708	50x4	719	2,657	145,6	0,119	690	58,9	0,374	OK
D10	1170	-15,22	2,96	2,668	50x4	719	2,617	143,4	0,122	690	60,5	0,251	OK
S13	1316	-338,58	2,37	2,132	90x4	1360	1,111	60,9	0,478	690	449	0,755	OK
S11	1345	-252,39	2,25	2,023	90x4	1360	1,055	57,8	0,509	690	478	0,529	OK
D13	1370	-33,59	3,10	2,791	50x4	719	2,738	150,0	0,112	690	55,8	0,602	OK
D14	1481	-40,92	3,15	2,832	50x4	719	2,778	152,3	0,109	690	54,3	0,754	OK
S9	1604	-161,92	2,13	1,914	60x4	879	1,539	84,3	0,302	690	183	0,883	OK
D9	1606	-15,14	2,92	2,628	50x4	719	2,578	141,3	0,125	690	62,2	0,243	OK
S12	1877	-293,90	2,31	2,078	80x4	1200	1,227	67,3	0,421	690	349	0,843	OK
D12	2227	-27,11	3,06	2,750	50x4	719	2,697	147,8	0,115	690	57,3	0,473	OK
Upper chord (y direction)	594	-1319,67	2,00	1,801	160x10	5890	0,540	29,6	0,821	690	3335	0,396	OK
Upper chord (z dir. in the middle)	594	-1319,67	4,00	3,602	160x10	5890	1,079	59,1	0,495	690	2014	0,655	OK
Upper chord (z dir. At the edge)	594	-934,10	6,00	5,403	160x10	5890	1,619	88,7	0,279	690	1134	0,824	OK
Lower chord (y direction)	674	-106,88	2,00	1,800	120x5	2270	0,702	38,5	0,724	690	1133	0,094	OK
Lower chord (z dir. in the middle)	674	-106,88	8,00	7,200	120x5	2270	2,807	153,8	0,107	690	168	0,635	OK
Lower chord (z dir. At the edge)	674	-94,61	10,00	9,000	120x5	2270	3,509	192,3	0,071	690	111	0,849	OK

Figure 15.2-2 Pressure members design

15.2.3. Interaction factors

Internal forces in the upper chord in the middle of the truss:

$$N_{Ed} = 1319,67 \text{ kN}$$



$$M_{Ed,y} = 15,29 \text{ kNm}$$

Internal forces are determined by a nonlinear calculation performed in the Dlubal software (see Appendix).

SHS160x10:

$$f_y = 690 \text{ MPa}$$

$$E = 210 \text{ GPa}$$

$$h = b = 160 \text{ mm}$$

$$A = 5890 \text{ mm}^2$$

$$W_{pl,y} = W_{pl,z} = 329 \cdot 10^3 \text{ mm}^3$$

$$I_y = I_z = 21,86 \cdot 10^6 \text{ mm}^4$$

$$i = 60,9 \text{ mm}$$

For the determination of the interaction factors k_{ij} , Appendix B will be used.

$$M_h = 4,462 \text{ kNm}$$

$$M_s = 15,290 \text{ kNm}$$

$$\psi \cdot M_h = 1,036 \text{ kNm}$$

$$\alpha_h = M_h / M_s = 0,29$$

$$\psi = 0,23$$

$$C_{my} = 0,95 + 0,05 \cdot \alpha_h = 0,95 + 0,05 \cdot 0,29 = 0,96$$

$$\begin{aligned} k_{yy} &= C_{my} \left(1 + (\bar{\lambda}_y - 0,2) \frac{N_{Ed}}{\chi_y \cdot A \cdot f_y / \gamma_{M0}} \right) \\ &= 0,96 \left(1 + (0,54 - 0,2) \frac{1319,67 \cdot 10^3}{0,821 \cdot 5890 \cdot 690/1} \right) = 1,094 \end{aligned}$$

$$\begin{aligned} k_{yy} &\leq C_{my} \left(1 + 0,8 \frac{N_{Ed}}{\chi_y \cdot N_{Rk} / \gamma_{M1}} \right) = 0,96 \left(1 + 0,8 \frac{1319,67 \cdot 10^3}{0,821 \cdot 5890 \cdot 690/1} \right) \\ &= 1,270 \end{aligned}$$

$$\mathbf{k_{yy} = 1,094}$$

$$\mathbf{k_{zy} = 0,6 \cdot k_{yy} = 0,657}$$



ULS verification:

$$\begin{aligned} & \frac{N_{Ed}}{\chi_y \cdot N_{Rk}/\gamma_{M1}} + k_{yy} \frac{M_{y,Ed}}{\chi_{LT} \cdot M_{y,Rk}/\gamma_{M1}} \\ &= \frac{1319,67 \cdot 10^3}{0,821 \cdot 4064,1 \cdot 10^3/1} + 1,094 \frac{15,29 \cdot 10^6}{1,0 \cdot 227 \cdot 10^6/1} \\ &= 0,40 + 0,07 = \mathbf{0,469} \leq \mathbf{1} \end{aligned}$$

$$\begin{aligned} & \frac{N_{Ed}}{\chi_z \cdot N_{Rk}/\gamma_{M1}} + k_{zy} \frac{M_{y,Ed}}{\chi_{LT} \cdot M_{y,Rk}} \\ &= \frac{1319,67 \cdot 10^3}{0,495 \cdot 4464,3 \cdot 10^3/1} + 0,657 \frac{15,29 \cdot 10^6}{1,0 \cdot 227 \cdot 10^6/1} \\ &= \mathbf{0,66} + \mathbf{0,04} = \mathbf{0,7} \leq \mathbf{1} \end{aligned}$$

OK

Buckling in z-direction (in the edge of the truss):

$$N_{Ed} = -934,10 \text{ kN}$$

$$M_{Ed,y} = 13,631 \text{ kNm}$$

$$M_h = 1,907 \text{ kNm}$$

$$M_s = 13,631 \text{ kNm}$$

$$\psi \cdot M_h = -0,748 \text{ kNm}$$

$$\alpha_h = M_h/M_s = 0,14$$

$$\psi = -0,39$$

$$C_{my} = 0,95 + 0,05 \cdot \alpha_h = 0,95 + 0,05 \cdot 0,14 = 0,957$$

$$\begin{aligned} k_{yy} &= C_{my} \left(1 + (\bar{\lambda}_y - 0,2) \frac{N_{Ed}}{\chi_y \cdot A \cdot f_y/\gamma_{M0}} \right) \\ &= 0,957 \left(1 + (0,440 - 0,2) \frac{934,10 \cdot 10^3}{0,821 \cdot 5890 \cdot 690/1} \right) = 1,048 \end{aligned}$$

$$\begin{aligned} k_{yy} &\leq C_{my} \left(1 + 0,8 \frac{N_{Ed}}{\chi_y \cdot N_{Rk}/\gamma_{M1}} \right) = 0,957 \left(1 + 0,8 \frac{934,10 \cdot 10^3}{0,821 \cdot 5890 \cdot \frac{690}{1}} \right) \\ &= 1,171 \end{aligned}$$

$$\mathbf{k_{yy} = 1,048}$$

$$\mathbf{k_{zy} = 0,6 \cdot k_{yy} = 0,629}$$



ULS verification:

$$\begin{aligned} \frac{N_{Ed}}{\chi_y \cdot N_{Rk}/\gamma_{M1}} + k_{yy} \frac{M_{y,Ed}}{\chi_{LT} \cdot M_{y,Rk}/\gamma_{M1}} \\ = \frac{934,10 \cdot 10^3}{0,821 \cdot 4064 \cdot 10^3/1} + 1,048 \frac{13,631 \cdot 10^6}{1,0 \cdot 140,76 \cdot 10^6/1} \\ = 0,28 + 0,06 = \mathbf{0,34} \leq \mathbf{1} \end{aligned}$$

$$\begin{aligned} \frac{N_{Ed}}{\chi_z \cdot N_{Rk}/\gamma_{M1}} + k_{zy} \frac{M_{y,Ed}}{\chi_{LT} \cdot M_{y,Rk}} \\ = \frac{934,10 \cdot 10^3}{0,279 \cdot 4064 \cdot 10^3/1} + 0,629 \frac{13,631 \cdot 10^6}{1,0 \cdot 227 \cdot 10^6/1} \\ = \mathbf{0,82} + \mathbf{0,04} = \mathbf{0,86} \leq \mathbf{1} \end{aligned}$$

OK

15.2.4. Joints

A detailed procedure for verifying the capacities of the joints is in Chapter 14.2 (page 109). Internal forces are shown on the Figure 14.2-2 (page 110).

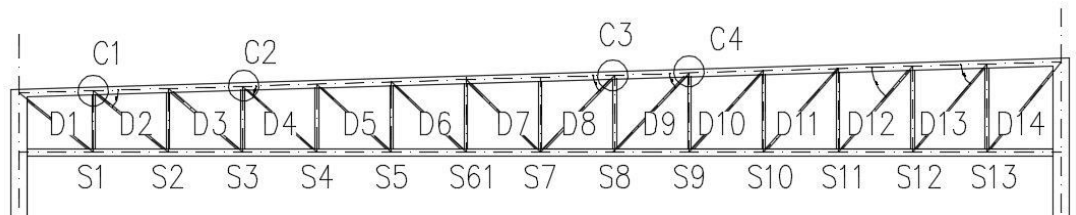

Figure 15.2-3 Members and joints numbering for verification

$A_0 =$	5890	mm ²
$f_{y0} =$	690	MPa
$f_{u0} =$	770	MPa
$b_0 =$	160	mm
$t_0 =$	10	mm
$b_0/t_0 =$	16	OK
$\gamma =$	8	
$\beta_w =$	1,0	
$f_u/(\beta_w \cdot \gamma_{M2}) =$	616	MPa
$f_u/1,25 =$	616	MPa



Diploma thesis
Possibilities of using HSS in truss beams – a parametric study
Static calculation

	C1	C2	C3	C4
SHS ₁ =	70x4	60x4	60x4	60x4
SHS ₂ =	50x4	50x4	50x4	50x4
b ₁ =	70 mm	60 mm	60 mm	60 mm
t ₁ =	4 mm	4 mm	4 mm	4 mm
f _{y1} =	690 MPa	690 MPa	690 MPa	690 MPa
b ₂ =	60 mm	50 mm	50 mm	50 mm
t ₂ =	4 mm	4 mm	4 mm	4 mm
f _{y2} =	690 MPa	690 MPa	690 MPa	690 MPa
N _{Ed,1} =	380,454 kN	933,5 kN	1308,4 kN	1245,5 kN
N _{Ed,2} =	695,458 kN	1180 kN	1247 kN	1142,64 kN
N _{Ed,3} =	319,146 kN	203,7 kN	114,287 kN	161,6 kN
N _{Ed,4} =	406,392 kN	214,4 kN	90,57 kN	152,4 kN
θ ₁ =	88,3 °	88,3 °	91,7 °	91,7 °
θ ₂ =	41,13 °	43,14 °	44,2 °	45,03 °
g=	13,36 mm	21,17 mm	14,02 mm	12,19 mm
b ₁ /b ₀ =	0,438 OK	0,375 OK	0,375 OK	0,375 OK
b ₂ /b ₀ =	0,375 OK	0,313 NO	0,313 NO	0,313 NO
b ₁ /t ₁ =	17,5 OK	15 OK	15 OK	15 OK
b ₂ /t ₂ =	15 OK	12,5 OK	12,5 OK	12,5 OK
t ₁ +t ₂ =	8 OK	8 OK	8 OK	8 OK
σ _{1,Ed} [MPa]	64,593	158,489	222,139	211,460
σ _{2,Ed} [MPa]	118,074	200,340	211,715	193,997
n=	0,171	0,290	0,307	0,281
β=	0,325	0,275	0,275	0,275
kn=	1,000	1,000	1,000	1,000
b _{eff1} [mm]	78,16	66,99	66,99	66,99
b _{eff2} [mm]	66,99	55,83	55,83	55,83
N _{1,Rd} [N]	998 352 OK	844 759 OK	844 759 OK	844 759 OK
N _{2,Rd} [N]	1 072 763 OK	873 189 OK	856 429 OK	843 946 OK
N _{i,Rd} [N]	1 275 351 OK	1 275 351 OK	1 275 351 OK	1 275 351 OK
N _{i,Rd} [N]	1 938 048 OK	1 864 318 OK	1 828 533 OK	1 801 881 OK

Range of validity:

Chord face failure

Chord shear



Vertical member failure	$N_{i,Rd}$ [N]	751 152 OK	637 536 OK	637 536 OK	637 536 OK
	$N_{i,Rd}$ [N]	637 536 OK	523 920 OK	523 920 OK	523 920 OK
Diagonal member failure	$N_{1,Rd}$ [N]	1 091 303 OK	1 026 540 OK	1 026 540 OK	1 026 540 OK
	$N_{2,Rd}$ [N]	1 879 546 OK	1 666 194 OK	1 611 756 OK	1 571 783 OK
Punching shear	a_1 =	3 mm	3 mm	3 mm	3 mm
	L_{w1} =	280 mm	240 mm	240 mm	240 mm
Welds	$\sigma_{\perp 3} = \tau_{\perp 3}$ [MPa]	268,66 OK	200,05 OK	112,24 OK	158,71 OK
	σ_3 [MPa]=	465 OK	347 OK	194 OK	275 OK
	$F_{x,3}$ =	306,1 kN	156,4 kN	64,9 kN	107,7 kN
	$F_{y,3}$ =	267,3 kN	146,6 kN	63,1 kN	107,8 kN
	a_4 =	5 mm	4 mm	3 mm	3 mm
	L_{w4} =	302 mm	246 mm	243 mm	241 mm
	$\sigma_{\perp 3} = \tau_{\perp 3}$ [MPa]	143,50 OK	116,67 OK	63,90 OK	105,12 OK
	$\tau_{\parallel,3}$ =	202,94 MPa	164,99 MPa	90,37 MPa	148,67 MPa
	σ_3 [MPa]=	600 OK	488 OK	267 OK	440 OK
	a_3+a_4 =	< g 8 OK	< g 7 OK	< g 6 OK	< g 6 OK

Table 15.2-2 Joints' design

Connections C3, C4 and C6 do not match the range of validity. The load bearing capacity has a reserve. As verified in joint design for truss S355 (see page 109 and appendix), when joint load capacity has a reserve this condition is neglected.

15.3. Comparison and evaluation

Steel material costs (i.e. costs calculated for the dead weight of the main steel structure- self weight of steel members plus an extra 15% for connections and additional steel) are calculated assuming that currently, these material values (for base steel material and welding consumables) are available:

S355: 800,3 €/t — 100%

S460: 869,3 €/t — 109 %



S690: 962,9 €/t — 120%

This prices based on the actual inquiry of hollow-section in RUUKKI supplier.

All members' cross-section of a truss in the hall designed in the previous chapters for clarity will be summarized in the table:

	length	S355			S460			S690		
	L [m]	SHS*	Weight [kg]	Price [€]	SHS*	Weight [kg]	Price [€]	SHS*	Weight [kg]	Price [€]
S1	1,64	90x5	21,5	14,97	80x4	15,5	11,68	70x4	13,4	11,20
D1	2,55	90x8	51,3	35,68	80x4	24,0	18,15	60x4	17,6	14,74
S2	1,70	70x5	17,0	11,84	60x6	16,8	12,71	70x4	13,9	11,62
D3	2,63	60x5	22,1	15,39	50x4	14,8	11,20	50x4	14,8	12,41
S3	1,76	60x5	14,9	10,34	60x4	12,2	9,20	60x4	12,2	10,19
D4	2,67	50x4	15,0	10,47	50x4	15,0	11,37	50x4	15,0	12,59
D2	2,59	70x5	25,9	17,99	70x4	21,1	15,94	50x4	14,6	12,22
D5	2,71	40x4	11,9	8,27	50x4	15,3	11,54	50x4	15,3	12,78
S5	1,89	50x4	10,6	7,40	50x4	10,6	8,04	50x4	10,6	8,90
S4	1,82	60x5	15,4	10,69	60x4	12,6	9,51	60x4	12,6	10,54
D6	2,75	40x4	12,1	8,40	50x4	15,5	11,72	50x4	15,5	12,98
S6	1,95	40x4	8,5	5,94	50x4	11,0	8,29	50x4	11,0	9,18
D8	2,88	40x4	12,6	8,79	50x4	16,2	12,26	50x4	16,2	13,58
S7	2,01	50x4	11,3	7,87	50x4	11,3	8,55	50x4	11,3	9,47
S8	2,07	60x5	17,4	12,11	60x4	14,3	10,78	60x4	14,3	11,94
S10	2,19	70x5	21,9	15,21	70x4	17,8	13,48	70x4	17,8	14,93
D7	2,79	40x4	12,2	8,52	50x4	15,7	11,89	50x4	15,7	13,17
D11	3,01	60x4	20,8	14,45	50x4	17,0	12,83	50x4	17,0	14,21
D10	2,96	50x4	16,7	11,63	50x4	16,7	12,64	50x4	16,7	14,00
S13	2,37	90x5	31,0	21,60	90x4	25,3	19,16	90x4	25,3	21,22
S11	2,25	80x5	26,1	18,15	80x4	21,2	15,99	90x4	24,1	20,14
D13	3,10	80x5	36,0	25,03	60x4	21,4	16,17	50x4	17,5	14,64
D14	3,15	90x5	41,2	28,69	70x4	25,6	19,39	50x4	17,7	14,86
S9	2,13	70x4	17,3	12,06	60x4	14,7	11,09	60x4	14,7	12,29
D9	2,92	50x4	12,8	8,92	50x4	16,5	12,45	50x4	16,5	13,79
S12	2,31	80x5	26,8	18,64	80x4	21,7	16,42	80x4	21,7	18,19
D12	3,06	70x5	30,5	21,24	60x4	21,1	15,93	50x4	17,2	14,43
Upper chord	28,01	180x10	1470,3	1023,21	160x10	1296,7	980,17	160x10	1296,4	1085,44
Lower chord	28,00	140x8	912,8	635,23	150x5	632,8	478,34	120x5	498,4	417,30
Total:			2948	2051		2390	1807		2225	1863
			100%	100%		81,1%	88,1%		75,5%	90,8%

Figure 15.3-1 Summarization of designed cross section for the truss



As seen from the previous table, a truss is a potentially good design using higher steel grade S460. Using S460 and S690 steel makes of 11,9% and 9,3% cost savings and 18,9% and 24,5% weight savings respectively.

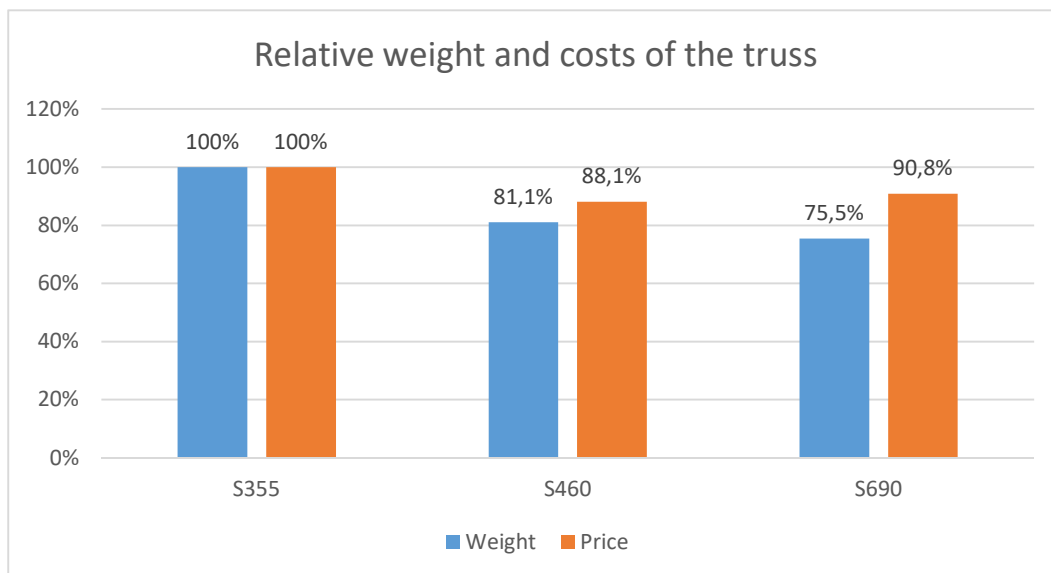

Figure 15.3-2 Relative weight and costs of the homogeneous trusses

By comparing the individual member's price, the hybrid trusses will be constructed: Truss no. 1 using the S355 and S460 steels; and hybrid Truss no. 2 using the S355 and S690 steels.

Hybrid truss (S355 and S460)				Hybrid truss (S355 and S690)			
Steel grade	SHS*	Weight [kg]	Price [€]	Steel grade	SHS*	Weight [kg]	Price [€]
S460	80x4	15,45	11,68	S690	70x4	13,38	11,20
S460	80x4	24,00	18,15	S690	60x4	17,60	14,74
S355	70x5	17,01	11,84	S690	70x4	13,88	11,62
S460	50x4	14,82	11,20	S690	50x4	14,82	12,41
S460	60x4	12,17	9,20	S690	60x4	12,17	10,19
S355	50x4	15,04	10,47	S355	50x4	15,04	10,47
S460	70x4	21,09	15,94	S690	50x4	14,60	12,22
S355	40x4	11,88	8,27	S355	40x4	11,88	8,27
S355	50x4	10,63	7,40	S355	50x4	10,63	7,40
S460	60x4	12,59	9,51	S690	60x4	12,59	10,54
S355	40x4	12,06	8,40	S355	40x4	12,06	8,40
S355	40x4	8,54	5,94	S355	40x4	8,54	5,94
S355	40x4	12,63	8,79	S355	40x4	12,63	8,79
S355	50x4	11,31	7,87	S355	50x4	11,31	7,87
S460	60x4	14,26	10,78	S690	60x4	14,26	11,94
S460	70x4	17,83	13,48	S690	70x4	17,83	14,93
S355	40x4	12,25	8,52	S355	40x4	12,25	8,52
S460	50x4	16,97	12,83	S690	50x4	16,97	14,21



S355	50x4	16,72	11,63	S355	50x4	16,72	11,63
S460	90x4	25,35	19,16	S690	90x4	25,35	21,22
S460	80x4	21,15	15,99	S355	80x5	26,08	18,15
S460	60x4	21,40	16,17	S690	50x4	17,49	14,64
S460	70x4	25,65	19,39	S690	50x4	17,75	14,86
S460	60x4	14,68	11,09	S355	70x4	17,34	12,06
S355	40x4	12,82	8,92	S355	40x4	12,82	8,92
S460	80x4	21,73	16,42	S690	80x4	21,73	18,19
S460	60x4	21,08	15,93	S690	50x4	17,23	14,43
S460	160x10	1296,68	980,17	S355	180x10	1470,32	1023,21
S460	150x5	632,80	478,34	S690	120x5	498,40	417,30
		2371	1783,5			2383,7	1764,3
		80,5%	87,1%			81,0%	86,1%

Figure 15.3-3 Comparison of designs hybrid Trusses

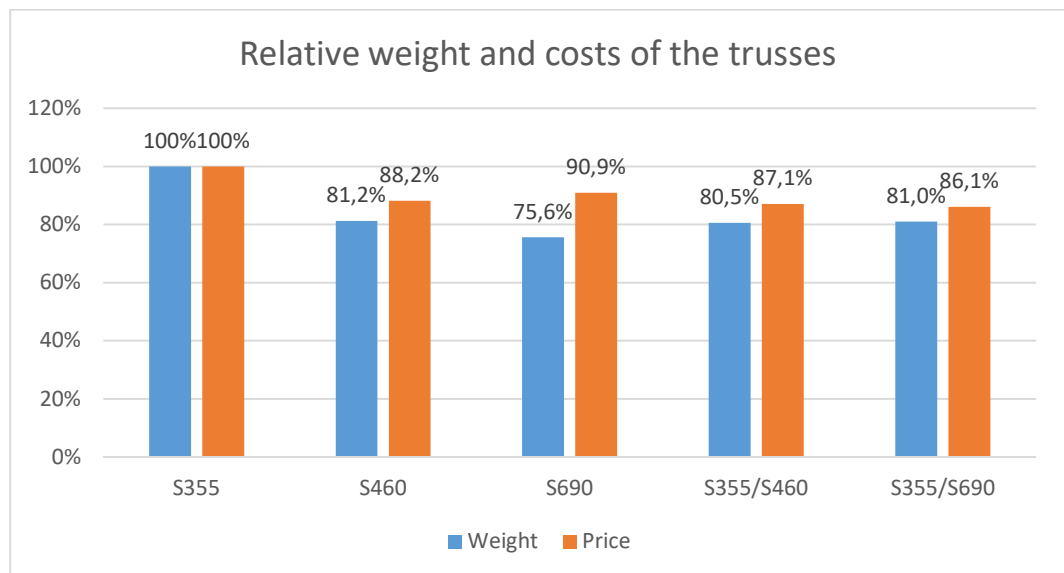

Figure 15.3-4 Relative weight and cost of the trusses (include hybrid)

Hybrid Truss 1 and Truss 2 offers small savings in comparison to truss “all S 460” and “all 690”: 1,2% and 2,2% price savings respectively. It is important to note that in these prices are not include other important costs, like fabrication, transportation, etc. which obviously have influence on final total costs of the truss design. Also, the lower self weight of S460 or S690 members wasn’t considered in the calculation.

Since the price of steel also affects the amount of the same elements, the S460 or S690 for the entire truss is more advantageous for the Nexen Tire project.



Part D

For better examine the efficiency of using high strength steel, it's necessary to take into consideration other parameters, such as various load values and span. In Part D, three trusses of 24, 36 and 48 m span are used for comparison. Each of them will carry 3 different loads. And each truss in 3 steel grades (S355, S460, S690).



16. Parametric study

16.1. Main parameters considered

For a more detailed examination of the usability of high strength steel, it is necessary to include the following parameters:

- Material strength — S355, S460, S690
- Truss span — 24m, 36m and 48m
- Load level — the one for Nexen TIRE building 23,328 kN/m (see page 44), 20 kN/m, 30 kN/m
- Production options

Geometry of the selected trusses:

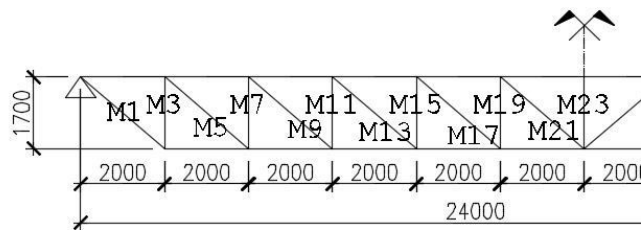

Figure 16.1-1 Geometry of the Truss No. 1

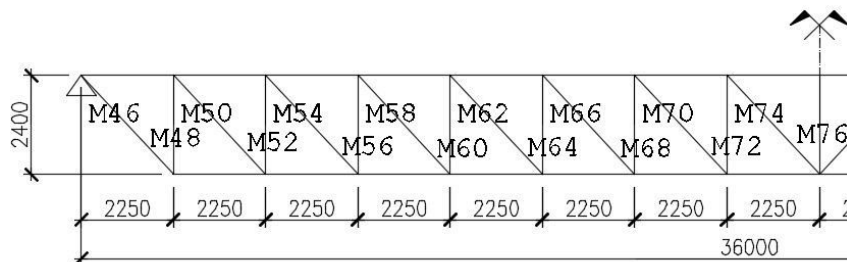

Figure 16.1-2 Geometry of the Truss No. 2

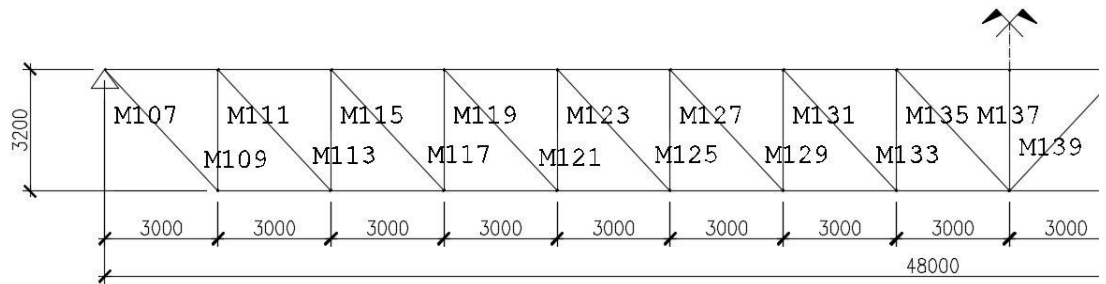

Figure 16.1-3 Geometry of the Truss No.3

Both, lower and upper chord, are laterally braced by joists (or vertical roof stiffeners) every 6 meters, to prevent buckling sideways.

16.2. Deflection

Firstly, it's important to verify deflection on the selected trusses. Deflection is calculated using Dlubal software using automated profile design (design steel modules, according to Eurocode 3).

Limit deflection (load 30 kN/m):

$$\delta_{lim,1} = L_1/250 = 24000/250 = 96 \text{ mm —for the Truss No.1}$$

$$\delta_{lim,2} = L_2/250 = 36000/250 = 144 \text{ mm —for the Truss No.2}$$

$$\delta_{lim,3} = L_3/250 = 48000/250 = 192 \text{ mm —for the Truss No.1}$$

16.3. Member design

To simplify the calculation, the combination of pressure + bending of the upper chord of the trusses is not considered. To simple compression resistance of the upper chord is added 10% reserve (to cover bending moment), critical profiles are verified in Dlubal software.

Joints is often a critical place in the truss. In part B, the most critical connection for the Nexen Tire project was calculated in the Idea Statica software. It is a time-consuming procedure. The procedure described in the Eurocode 1993-1-8 [5] is used to assess the collar in Part D.

All diagonal and vertical members to upper (lower) chord joints in Truss1, Truss2 and Truss3 are overlapped. To comply the Range of validity conditions in Table 7.8 Eurocode [5], if size of the top (bottom) chord 120 mm, the diagonal size may be at least 80 mm (at



an angle of 41 °). This process turned out to be very uneconomical. Critical connections will be verified in the Idea Statica software.

The procedure for the design of truss cross-sections:

- 1) Based on the internal forces (taken from the Dlubal software) profiles will be designed for 80-100% load capacities;
- 2) Verification of selected joints - if the profiles does not satisfy, increasing profiles dimension (or using alternative joints);
- 3) Edit cross-sections in the model in Dlubal software, deflection verification.

Designed cross sections and all the values needed for the design are in the appendix.

16.4. Comparison and evaluation

Steel material costs (i.e. costs calculated for the dead weight of the main steel structure- self weight of steel members plus an extra 15% for connections and additional steel) are calculated assuming that currently, these material values (for base steel material and welding consumables) are available:

S355: 800,3 €/t — 100%

S460: 869,3 €/t — 109 %

S690: 962,9 €/t — 120%

This prices based on the actual inquiry of hollow-section in RUUKKI supplier.

This calculation only serves for an estimation of benefits that HSS can offer due to reduced dimensions and dead weight, when designing on the same basis (i.e. assume given geometry, length, width, height, brace angles etc.).

Weight comparison:

	Truss 24m			Truss 36m			Truss 48m		
Load [kN/m]	20	23,33	30	20	23,33	30	20	23,33	30
S355	1272,0	1552,8	1948,6	3074,8	3311,5	3946,2	4693,7	5705,7	6591,1
S460	1053,4	1261,1	1417,5	2781,9	2959,7	3539,1	4210,8	4873,2	5475,5
S690	891,4	1048,9	1078,6	2374,1	2104,1	2656,4	3614,6	3861,3	4887,6

Figure 16.4-1 Actual weight of the trusses

	Truss 24m			Truss 36m			Truss 48m		
Load [kN/m]	20	23,33	30	20	23,33	30	20	23,33	30
S355	100,0%	100,0%	100,0%	100,0%	100,0%	100,0%	100,0%	100,0%	100,0%
S460	82,8%	81,2%	72,7%	90,5%	89,4%	89,7%	89,7%	85,4%	83,1%



S690	70,1%	67,5%	55,4%	77,2%	63,5%	67,3%	77,0%	67,7%	74,2%
------	-------	-------	-------	-------	-------	-------	-------	-------	-------

Figure 16.4-2 Relative weight comparison

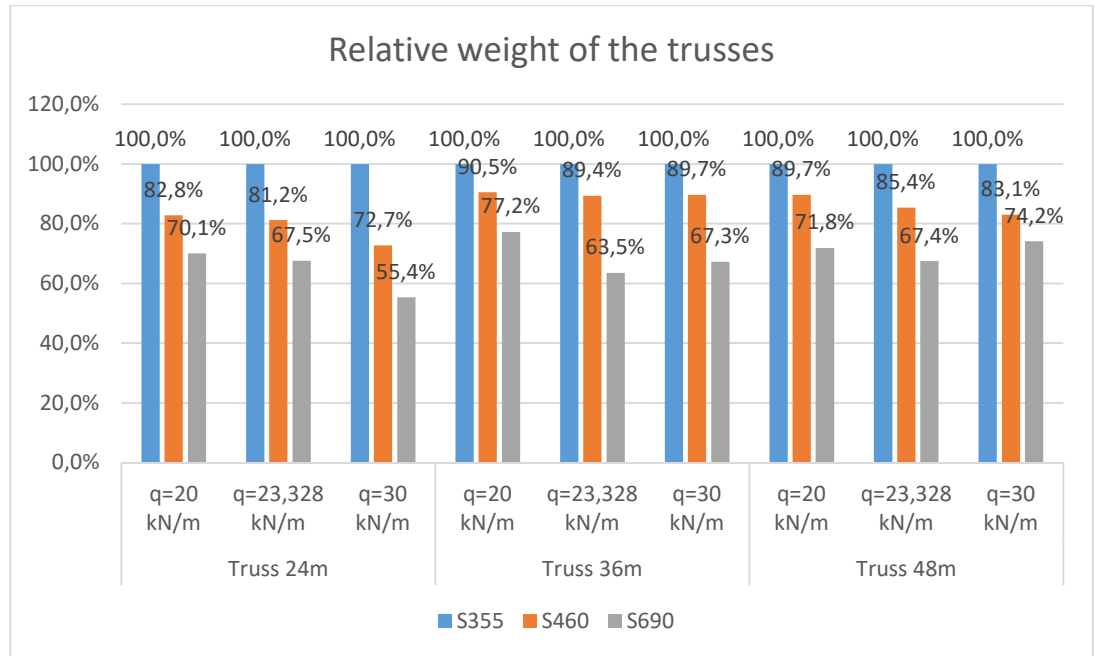

Figure 16.4-3 Relative weight of the truss

As can be seen from the previous tables, the use of high-strength steels can save up to 40% by weight. In all cases, it is more advantageous to use HSS. The weight of the lower and upper chord 24 meters truss S355 (30 kN/m load) is almost 2 times greater than the weight of the lower and upper chord of the S690 truss. The size of the beams also limits the size of the diagonals (for larger chord must be larger diagonals).

Average weight savings 15% for S460 and 30% for S690.

But as it is known, the price of high-strength steel is more expensive than the S355, it is important to include the price in comparison:

Load [kN/m]	Truss 24m			Truss 36m			Truss 48m		
	20	23,33	30	20	23,33	30	20	23,33	30
S355	1018,0	1242,7	1559,5	2460,7	2650,2	3158,1	3756,3	4566,2	5274,8
S460	915,7	1096,3	1232,2	2418,3	2572,9	3076,5	3660,4	4236,3	4759,8
S690	858,3	1010,0	1038,5	2285,9	2025,9	2557,8	3480,4	3717,9	4706,1

Figure 16.4-4 Actual prices of the trusses

Load [kN/m]	Truss 24m			Truss 36m			Truss 48m		
	20	23,33	30	20	23,33	30	20	23,33	30
S355	100,0%	100,0%	100,0%	100,0%	100,0%	100,0%	100,0%	100,0%	100,0%



S460	90,0%	88,2%	79,0%	98,3%	97,1%	97,4%	97,4%	92,8%	90,2%
S690	84,3%	81,3%	66,6%	92,9%	76,4%	81,0%	86,4%	81,1%	89,2%

Figure 16.4-5 Relative prices of the trusses

Average weight savings 7,7% for S460 and 17,9% for S690. Transportation and corrosion protection costs may be less for the high strength steel designs due to lower weight and surface area.

Material costs alone, based on steel dead weight, in all cases less when using high-strength steel. Most save on the shortest girder beam with the greatest load.

Only Truss No. 3 48m S690 with a load of 30 kN / m did not meet the limit deflection of all the beam considered (10% greater than limit). It can be solved by changing the geometry of the truss, but that can increase the weight by about 5%.

It is important to note that in these prices are not include other important costs, like fabrication, transportation, etc. which obviously have influence on final total costs of the truss design. Also, the lower self-weight of S460 or S690 members wasn't considered in the calculation.

However, this conclusion is based on the current steel prices and the fact that the same design is used for both materials (equivalent design solutions -same design concept- has been considered).

The price of high strength steel material is currently high in comparison to normal S355 steel grade (20% more expensive). However, this fact is expected to change in the future as the market demand for new steel grades will become higher.

17. Conclusions

Can high strength steel help reducing total costs in construction?

In this thesis have been presented detailed design of a load-bearing steel structure of one expansion unit of the NEXEN Tire project. It contains design of 28 meters steel truss using high strength steel (S460 and S690) and a comparison to the previous design, hybrid truss design and evaluation of the most advantageous variant.

- ✓ In Part C and D it has been shown that trusses using high strength steel grades can offer competitive and cost effective solutions.
- ✓ The choice for a truss geometry with its specific boundary conditions influences whether high strength steel will be favorable or not. The most advantageous for the tensile members.



- ✓ Application of high strength steel in truss design results in large weight savings (e.g. S690 steel grade truss design can result in over 40% steel weight reduction in comparison to an equivalent design with S355 steel).
- ✓ Considering equivalent high strength steel and S355 steel truss, it is estimated that lower steel self-weight that can be achieved with HSS. It may have an influence on foundations (especially for large spans), transportation, lifting and erection costs, while smaller cross sectional areas will have a positive effect on maintenance (e.g. smaller painted area required for corrosion protection) and fabrication (especially welding) costs, especially in small thicknesses.
- ✓ It was eventually not possible to calculate the total costs in detail (including fabrication, erection, transportation and maintenance). However, it is expected to be in favor of high strength steel truss designs (based on previous point)



18. List of Figures

Figure 1.1-1 Relative weights of the trusses – KT- optimized [1].....	7
Figure 1.2-1 Historical development of rolled steel products [2]	10
Figure 1.4-1 Stress-strain curves [2].....	11
Figure 1.4-2 Yield strength and ductility [2].....	12
Figure 1.6-1 Building plan.....	17
Figure 1.6-2 Cross-section A-A	17
Figure 1.6-3 Geometry of the selected truss	18
Figure 4.2-1 Snow load shape coefficient [2].....	20
Figure 4.2-2 Snow load shape coefficients.....	21
Figure 4.2-3 Longitudinal wind load zone	23
Figure 4.2-4 Transversal wind load zone.....	23
Figure 4.2-5 Pressure on surfaces	24
Figure 4.2-6 Principle sketch of longitudinal wind loads	26
Figure 4.2-7 Principle sketch of transversal wind loads (X+)	26
Figure 4.2-8 Principle sketch of transversal wind loads (X-)	26
Figure 5.2-1 Internal force in lower truss (CO2).....	28
Figure 6.1-1 Scheme of roof system without purlin.....	30
Figure 6.1-2 Deflection.....	31
Figure 6.1-3 Shear forces and reaction	32
Figure 6.1-4 Bending moments	33
Figure 6.1-5 Deflection.....	34
Figure 6.1-6 Shear forces and reaction	36
Figure 6.1-7 Bending moments	37
Figure 6.2-1 Scheme of roof system with purlin	38
Figure 6.2-2 Deflection.....	38
Figure 8.2-1 Geometry of the truss 1	43
Figure 8.2-2 Geometry of the truss.....	43
Figure 8.2-3 Geometry of the truss 3	43
Figure 8.2-4 Geometry of the truss 4	44
Figure 8.2-5 Geometry of the truss 5	44
Figure 8.4-1 Weight dependence on truss heights	45
Figure 8.5-1 Statical model of the truss	46



Figure 8.6-1 3D model, part of the object.....	47
Figure 9.6-1 Buckling length of the upper and lower chords.....	54
Figure 9.6-2 Internal forces in the upper chord (CO1).....	55
Figure 9.6-3 Internal forces	57
Figure 9.6-4 Internal forces in the lower chord CO3.....	60
Figure 9.6-5 Global deflection on the truss.....	63
Figure 9.7-1 Deflection on the column (envelope)	64
Figure 9.7-2 Internal forces in the column (CO2).....	65
Figure 9.7-3 Internal forces of the column	70
Figure 9.7-1 3D model of roof bracing	73
Figure 10.1-1 Internal forces in the roof bracing system	73
Figure 10.2-1 3D model of vertical bracing	77
Figure 13.1-1 Sketch of the load on the floor	83
Figure 13.1-2 Slab cross-section.....	83
Figure 13.1-3 Bending moments on the concrete slab	84
Figure 13.1-4 Static load scheme at the mounting stage.....	85
Figure 13.1-5 Plastic bending capacity.....	88
Figure 13.1-6 Scheme of the studs geometry	88
Figure 13.1-7 Scheme of the studs geometry	92
Figure 13.1-9 Position of the primary beam	93
Figure 13.1-8 Static scheme of beam load	93
Figure 13.1-10 Static scheme of beam load.....	97
Figure 13.1-11 Position of the primary beam	97
Figure 13.1-12 force balance in the cross section.....	98
Figure 13.2-1 Sketch of the roof construction	100
Figure 13.2-2 Load on the roof.....	100
Figure 13.3-1 deformations on the column	102
Figure 13.3-2 Internal forces on internal column	102
Figure 14.1-1 Truss connection	104
Figure 14.1-2 Scheme of the column weld.....	108
Figure 14.2-1 Members and joints numbering for verification.....	109
Figure 14.2-2 Internal forces in the selected members	110
Figure 14.2-3 Scheme of gap joint	110
Figure 14.3-1 Placement of the bolted connections.....	114



Figure 14.3-2 Scheme of the connection	114
Figure 14.4-1 Scheme of the roof bracing connection.....	117
Figure 14.5-1 Sketch of the connection	120
Figure 14.6-1 Scheme of the primary beam connection.....	122
Figure 14.7-1 Sketch of the column foundation (HEA240)	124
Figure 14.7-2 Effective area of the base plate	125
Figure 14.8-1 Scheme of thee base plate.....	126
Figure 14.8-2 Effective area of the base plate	126
Figure 14.8-3 Scheme of the bracing connection	128
Figure 14.8-4 Scheme of the welds.....	129
Figure 15.1-1 Members and joints numbering for verification.....	136
Figure 15.2-1 Tensile members profile design	139
Figure 15.2-2 Pressure members design.....	140
Figure 15.2-3 Members and joints numbering for verification.....	143
Figure 15.3-1 Summarization of designed cross section for the truss.....	146
Figure 15.3-2 Relative weight and costs of the homogeneous trusses	147
Figure 15.3-3 Comparison of designs hybrid Trusses.....	148
Figure 15.3-4 Relative weight and cost of the trusses (include hybrid).....	148
Figure 16.1-1 Geometry of the Truss No. 1.....	150
Figure 16.1-2 Geometry of the Truss No. 2.....	150
Figure 16.1-3 Geometry of the Truss No.3.....	151
Figure 16.4-1 Actual weight of the trusses	152
Figure 16.4-2Relative weight comparison.....	153
Figure 16.4-3 Relative weight of the truss	153
Figure 16.4-4 Actual prices of the trusses.....	153
Figure 16.4-5 Relative prices of the trusses	154



19. List of Tables

Table 1.1-1 Available steel assortment	7
Table 4.1-1 Summary of permanent loads	19
Table 4.2-1 Live load on the roof	19
Table 4.2-2 Live load in office part	19
Table 4.2-3 Wind coefficients and loads	22
Table 4.2-4 Summary of openings areas	24
Table 5.1-1 Internal forces in the columns	28
Table 5.2-1 Internal forces in truss (envelope)	29
Table 5.2-1 loads on roof	30
Table 6.2-1 Loads on purlin at the center of the roof	39
Table 6.2-2 Loads on purlin at the edge of the roof	40
Table 6.3-1 Weight of the roof structure (kg/m ²)	41
Table 8.1-1 Yield and ultimate strengths of steel grades under consideration	42
Table 8.3-1 Load combination on trusses	45
Table 8.4-1 Comparison variants of trusses	45
Table 9.5-1 Internal forces envelope	51
Table 9.6-1 Diagonal and vertical members' numbering	52
Table 9.6-2 Tensile members profile design	52
Table 9.6-3 Diagonal and vertical members' design	54
Table 9.7-1 Column deflection	70
Table 10.2-1 Design of roof bracing members	76
Table 11.1-1 Internal forces in the vertical bracing	77
Table 11.2-1 internal forces in vertical bracing	78
Table 12.1-1 Internal forces in the wall bracings	79
Table 12.2-1 Wall bracing profile design	81
Table 13.1-1 Sketch of the floor construction	81
Table 13.1-2 Permanent load on the trapezoidal sheet	82
Table 13.1-3 Imposed load on the trapezoidal sheet	82
Table 13.1-4 Permanent load on the floor construction	82
Table 13.1-5 Imposed loads on the floor structures	82
Table 13.1-6 Permanent load	86
Table 13.1-7 Imposed load	86



Table 14.2-1 Input data of selected joints.....	114
Table 14.4-1 Joint bracing to the plate	118
Table 14.7-1 Internal forces in the columns base plate.....	124
Table 15.1-1 Diagonal and vertical members' numbering S460.....	131
Table 15.2-1 Diagonal and vertical members' numbering S690.....	138



20. Bibliography

- [1] I. Sorsa, "High strength steels in construction," RUUKKI, Peräseinäjoki, 2014.
- [2] EN 1991-1-3, Eurocode 1: Actions on structures – Part 1-3: General actions – Snow actions, European Standard, 2005.
- [3] EN 1993-1-3, Eurocode 3: Design of steel structures – Part 1-3: General rules - Supplementary rules for cold-formed members and sheeting, Management Centre, 2006.
- [4] EN 1993-1-1, Eurocode 3: Design of steel structures – Part 1-1: General rules and rules for buildings, EUROPEAN STANDARD, 2005.
- [5] EN 1993-1-8, Eurocode 3: Design of steel structures - Part 1-8: Design of, Brussels: EUROPEAN COMMITTEE FOR STANDARDIZATION, 2005.
- [6] P. RJM, "Fatigue strength of welded connections made of very high strength cast and rolled steels. PhD thesis.," Delft University of Technology, Delft, 2011.
- [7] EN 1991-1-4, Eurocode 1: Actions on structures – Part 1- 4: General actions – Wind actions, European Standard, 2007.
- [8] R. Willms, High Strength Steel for Steel Constructions, DILLINGER HUTTE GTS, 2009.
- [9] M. E. T. V. Michal Jandera, OCELOVÉ KONSTRUKCE 01 - Cvičení, Praha: ČVUT FSv, 2015.

CZECH TECHNICAL UNIVERSITY IN PRAGUE

FACULTY OF CIVIL ENGINEERING

DEPARTMENT OF STEEL AND TIMBER STRUCTURES

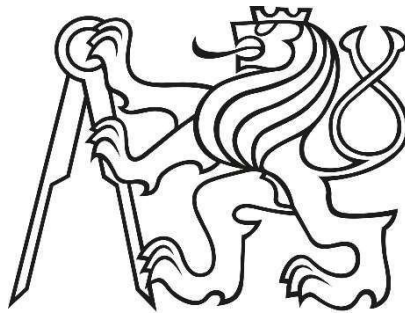

DIPLOMA THESIS

Possibilities of using HSS in truss beams – a parametric study

DRAWING DOCUMENTATION

Name: Bc. Nina Feber

Adviser: doc. Ing. Michal Jandera, Ph.D.

Prague 2018

List of drawings

Drawing No. 1	Roof construction (scale 1:200)
	Cross-sections (scale 1:100, 1:200)
	Truss geometry (1:100)
Drawing No. 2	Floor construction (scale 1:200)
	Cross sections (1:200)
Drawing No. 3	Details (scale 1:10)

ROOF CONSTRUCTION
1:200

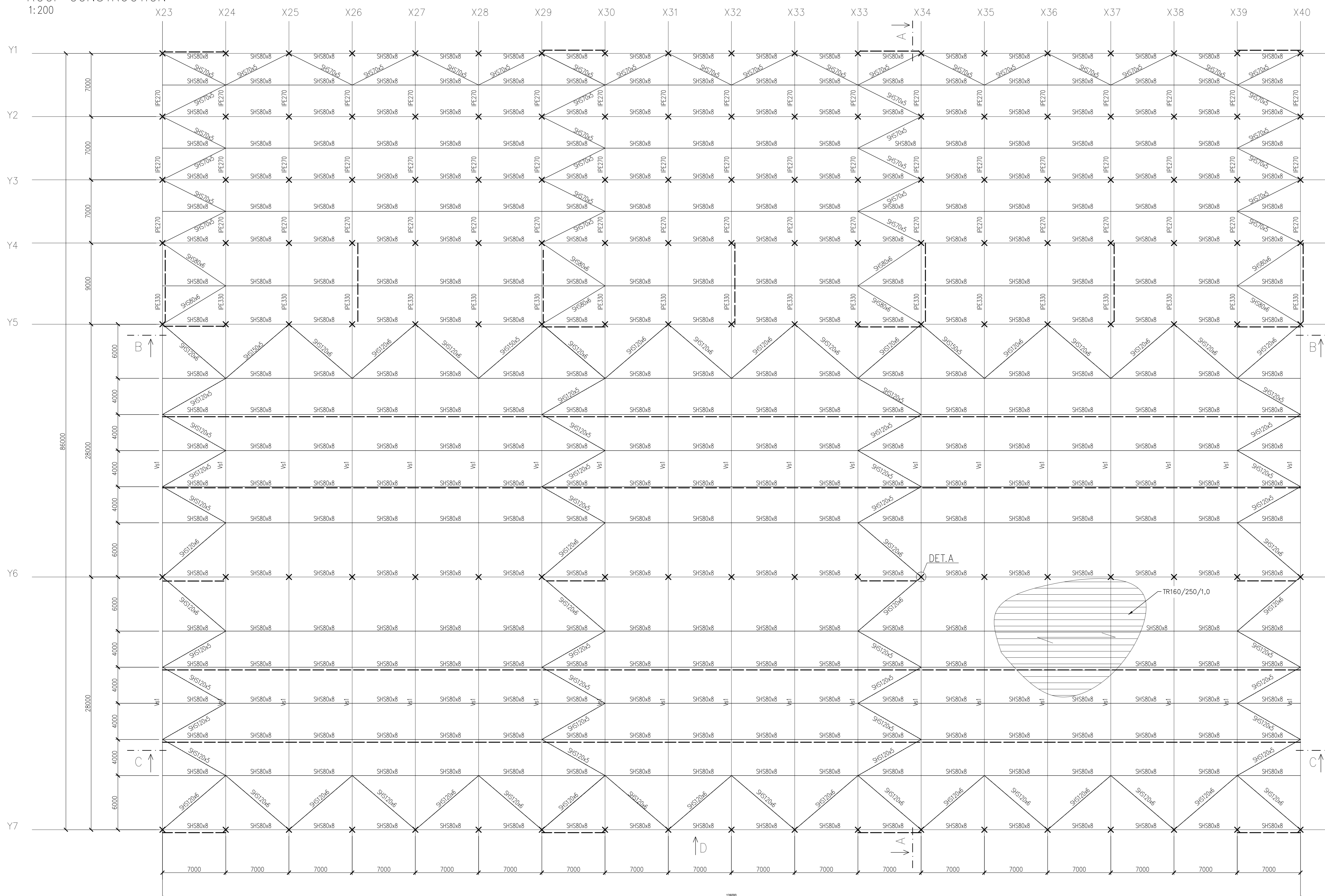

GEOMETRY OF THE TRUSS V1
1:100

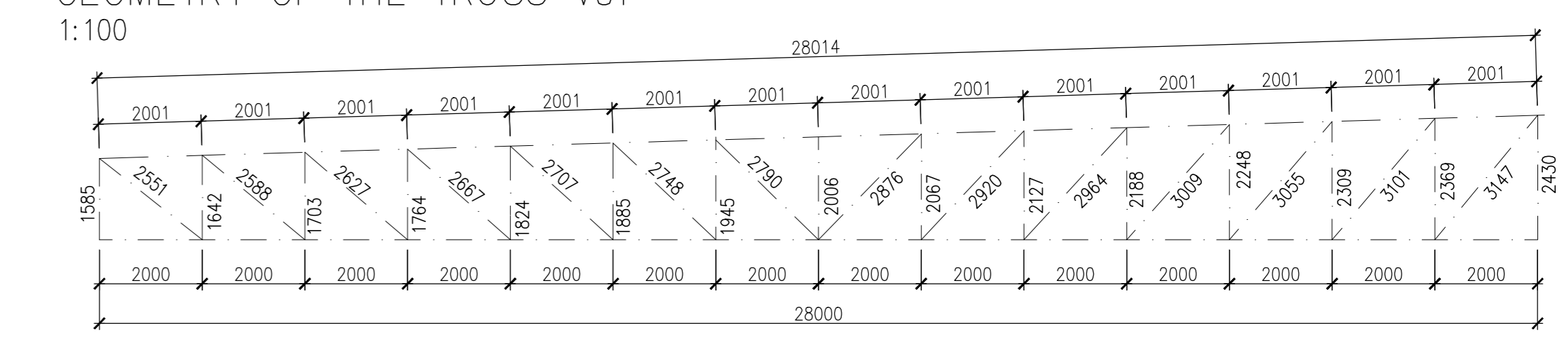

CROSS-SECTION C-C'
1:100

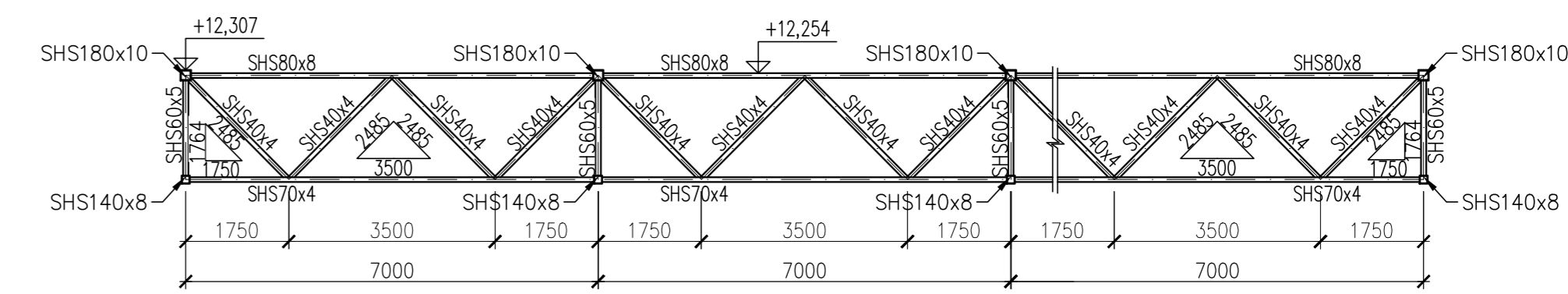

CROSS-SECTION A-A'
1:100

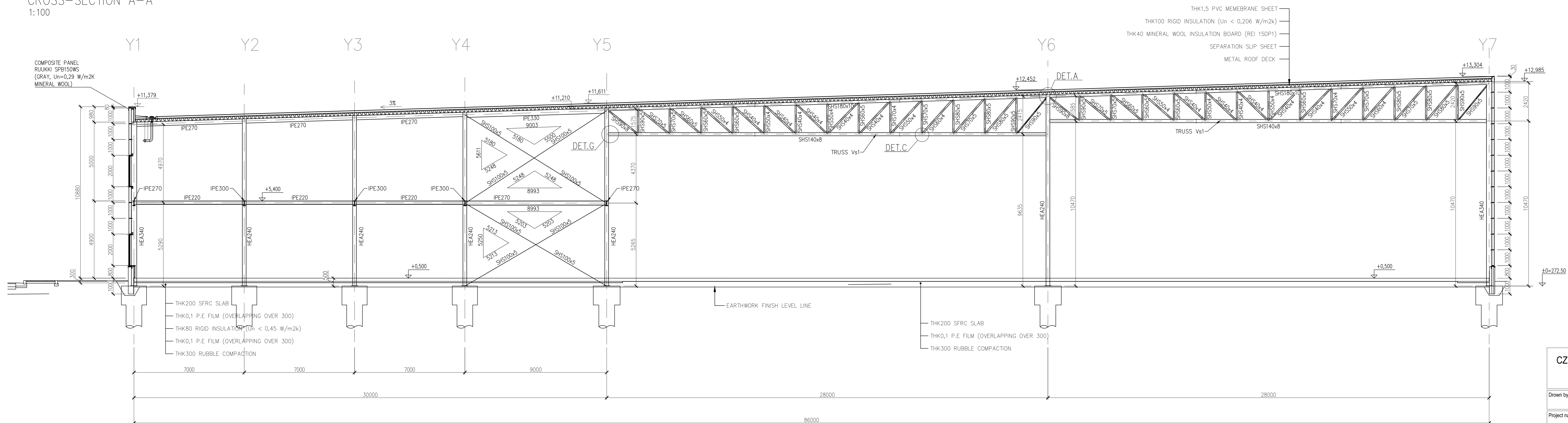

STEEL: S355JR - IF NOT OTHERWISE NOTED
S320GD - TRAPEZOID SHEETS
CONCRETE: C20/25 - FOUNDATION
C30/37 - FLOOR CONSTRUCTION
BOLTS: 8.8 - IF NOT OTHERWISE NOTED

CZECH TECHNICAL UNIVERSITY IN PRAGUE FACULTY OF CIVIL ENGINEERING Department of Steel and Timber Structures		
Drawn by: Bc. Nina Feber	Tutor: doc. Ing. Michal Jandera, Ph.D.	
Project name: Diploma thesis - NEXEN TIRE		Scale: 1:200, 1:100, 1:10
Drawing name: Roof plan, cross sections		Date: 2.01.2018
Drawing No: 01		

FLOOR PLAN +5,400
1:200

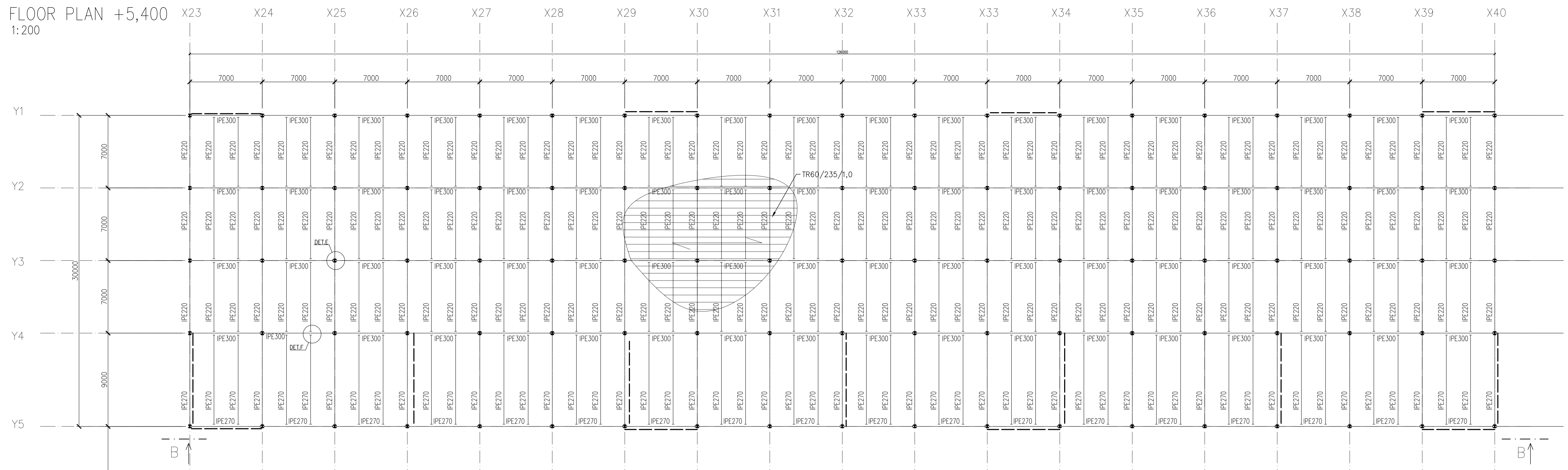

B-B'
1:200

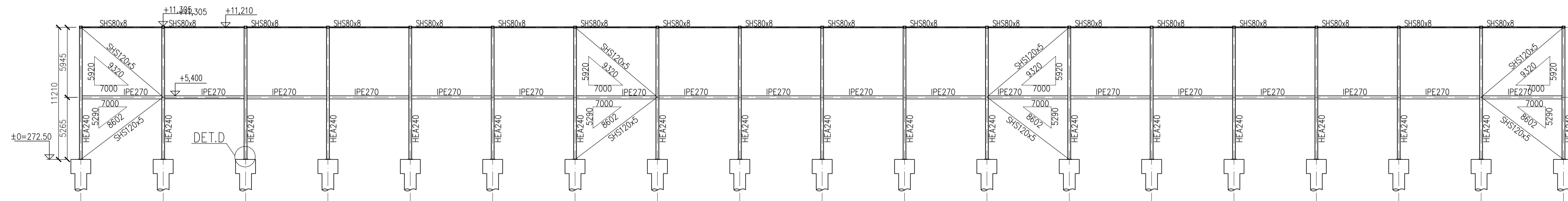

VIEW D
1:200

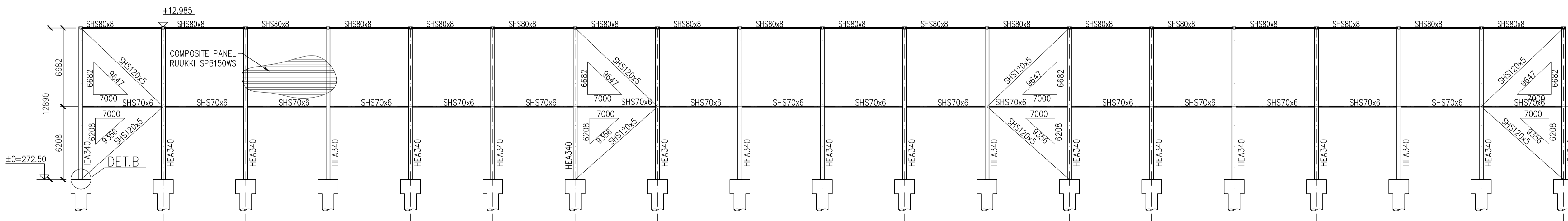

STEEL: S355JR - IF NOT OTHERWISE NOTED

S320GD - TRAPEZOIDAL SHEETS
CONCRETE: C20/25 - FOUNDATION
C30/37 - FLOOR CONSTRUCTION
BOLTS: 8.8 - IF NOT OTHERWISE NOTED

CZECH TECHNICAL UNIVERSITY IN PRAGUE
FACULTY OF CIVIL ENGINEERING
Department of Steel and Timber Structures



Drawn by: **Bc. Nina Feber** Tutor: **doc. Ing. Michal Jandera, Ph.D.**

Project name: **Diploma thesis - NEXEN TIRE** Scale: **1:200**
Date: **2.01.2018**

Drawing name: **Floor plan +4,500, cross sections** Drawing No: **02**

DETAIL A

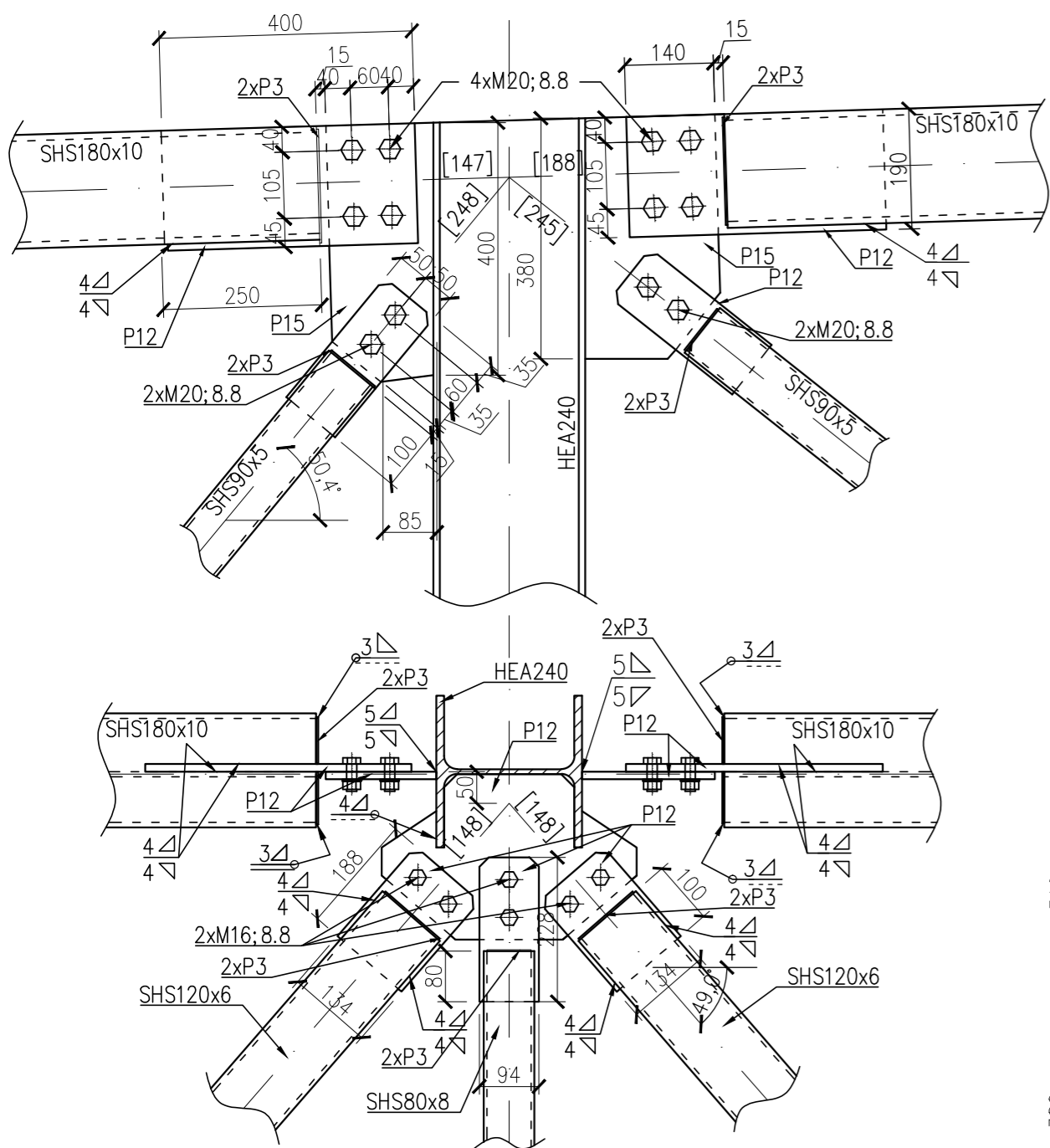

DETAIL B

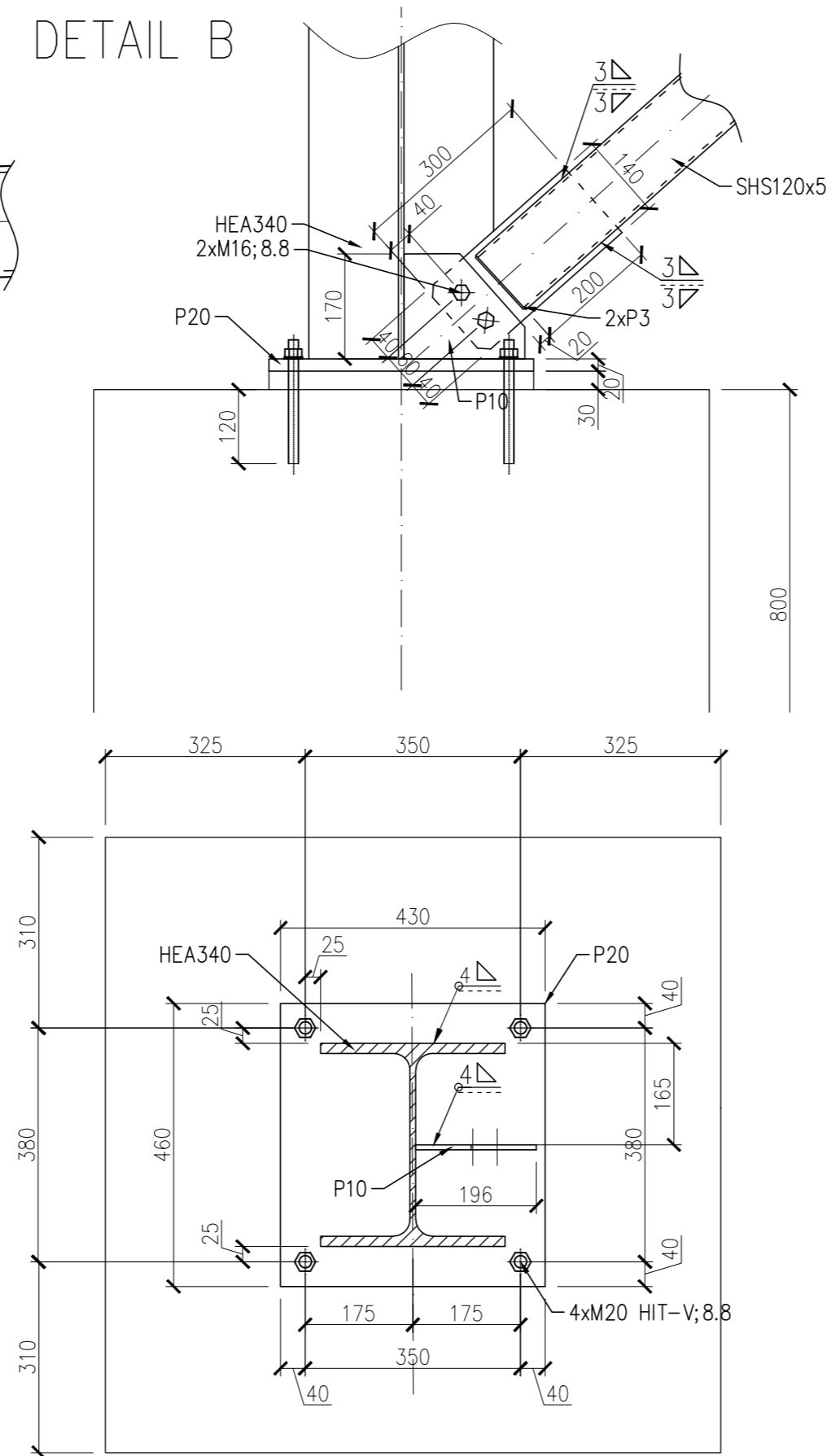

DETAIL C

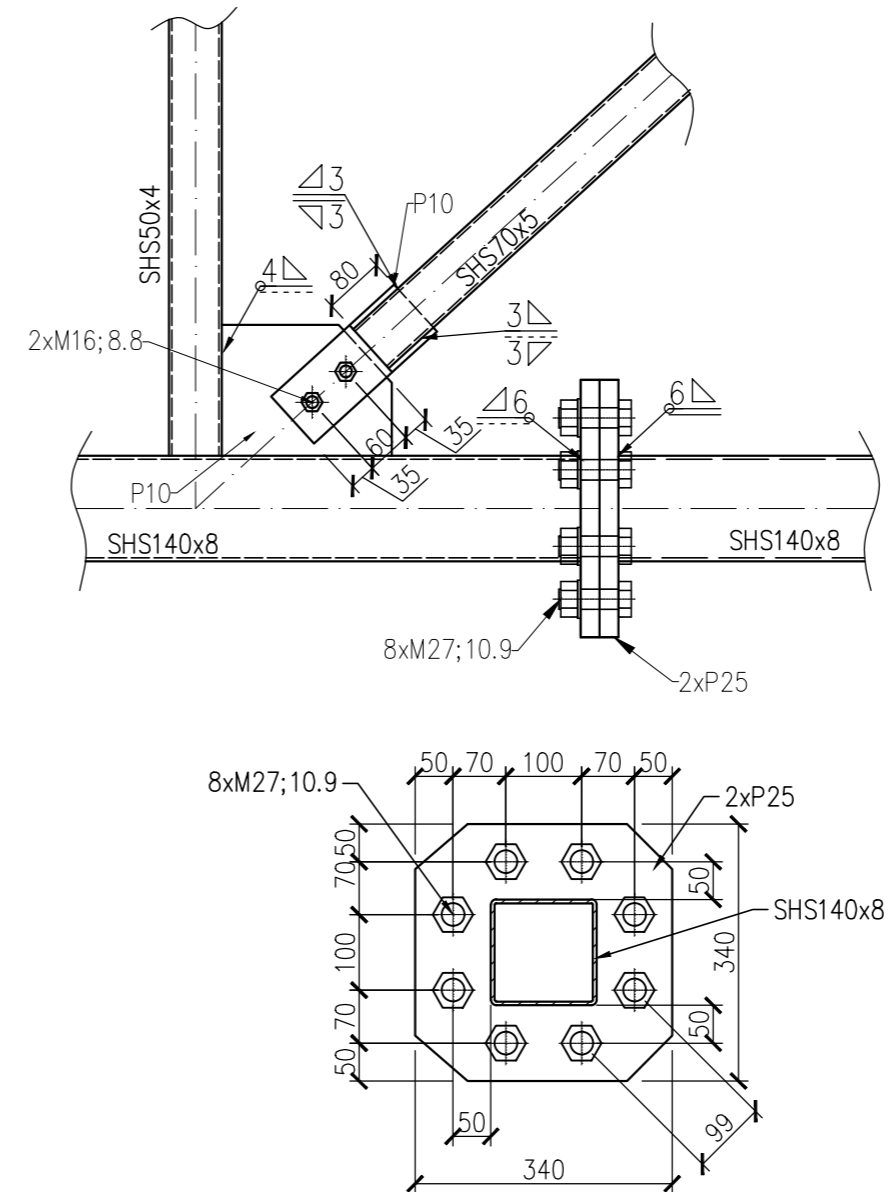

DETAIL D

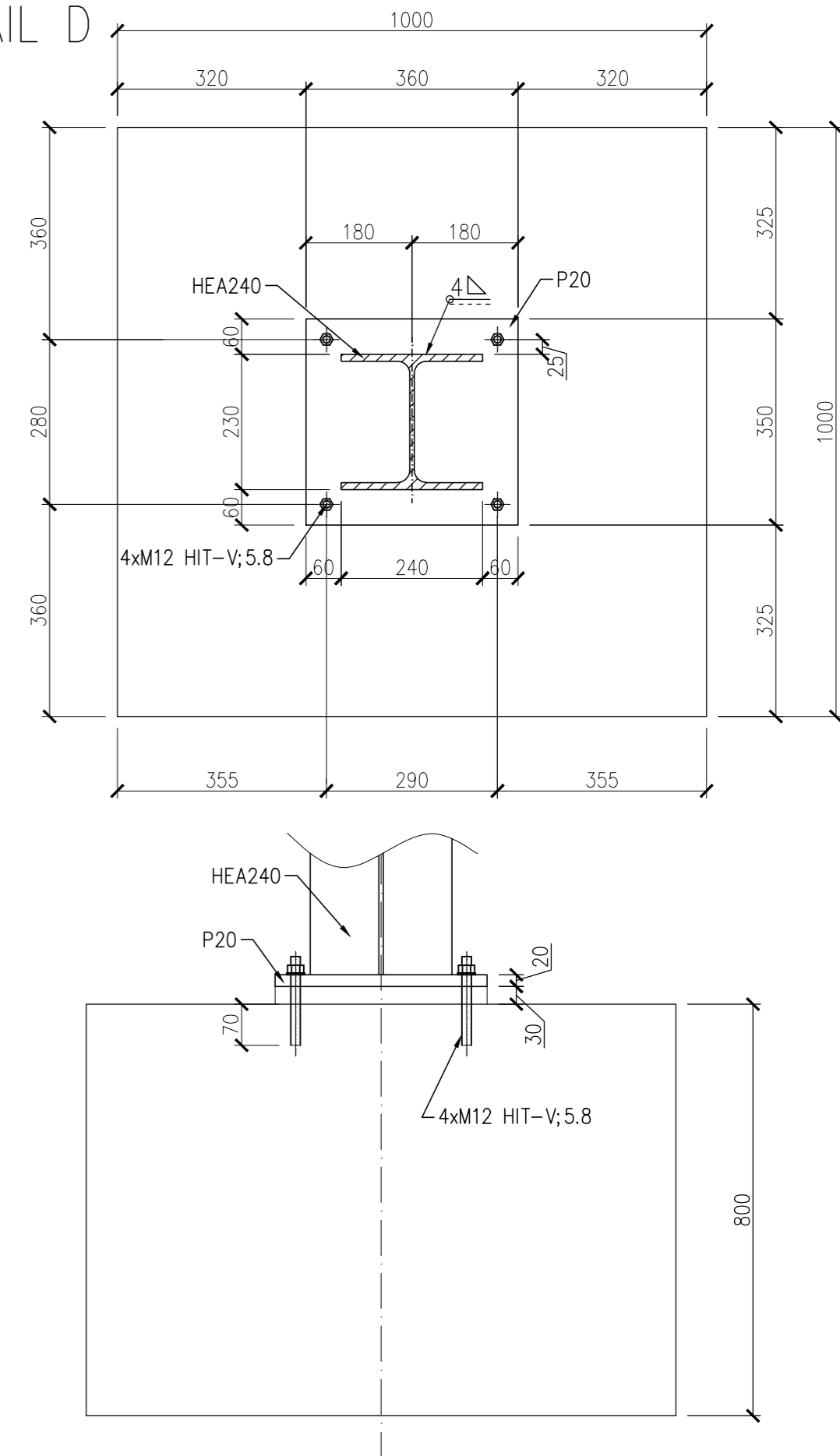

DETAIL G

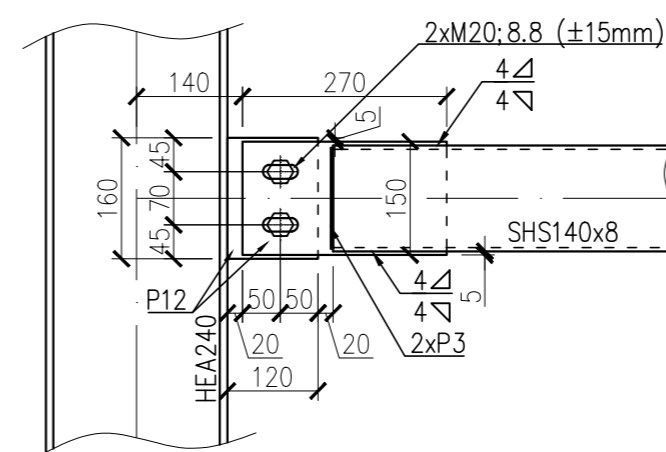

DETAIL E

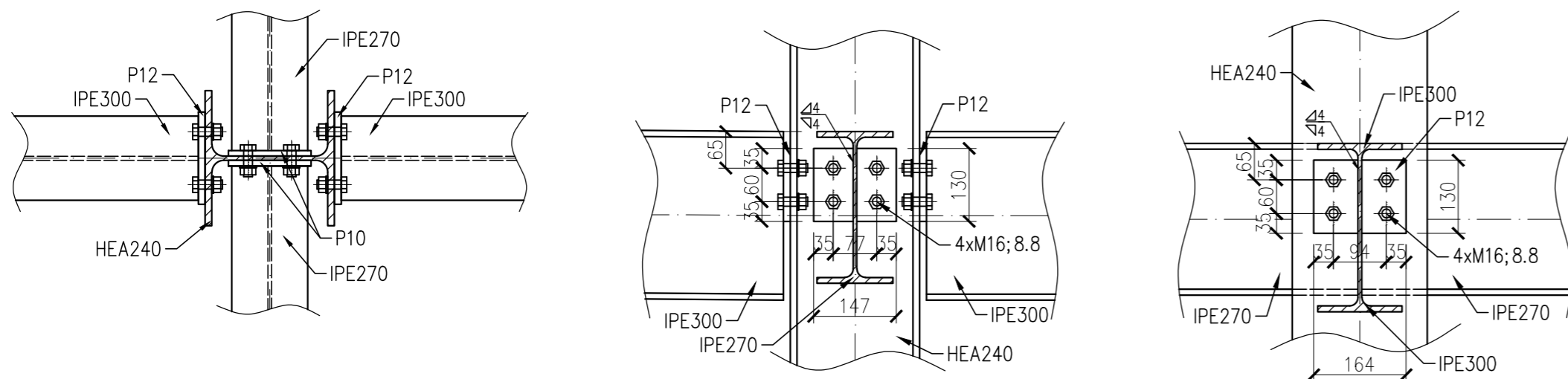

DETAIL F



STEEL: S355JR – IF NOT OTHERWISE NOTED
 S320GD – TRAPEZOIDAL SHEETS
 CONCRETE: C20/25 – FOUNDATION
 C30/37 – FLOOR CONSTRUCTION
 BOLTS: 8.8 – IF NOT OTHERWISE NOTED

CZECH TECHNICAL UNIVERSITY IN PRAGUE
 FACULTY OF CIVIL ENGINEERING
 Department of Steel and Timber Structures



Drawn by:	Bc. Nina Feber	Tutor:	doc. Ing. Michal Jandera, Ph.D.
Project name:	Diploma thesis - NEXEN TIRE		Scale: 1:10
			Date: 2.01.2018
Drawing name:	Details	Drawing No:	03