

UTAHOVACI MOMENTY JSOU NAVRZENE PODLE NORMY VDI 2230

NO	LINEARNI VEDENI DRYLIN N	21290-4030K900	2	1
20	VOZIK DRYLIN N	21290-4020	2	1
26	PRIVEVNOVACI ELEMENT	FESTO LBN-20-25	1	1
27	KLOBOVA KONCOVKA	FESTO SSS M8	1	1
28	PNEUMATICKY VALEC	FESTO DSHU 20-180	1	1
25	LASEROVA NAVAROVACI HLAVA	LASEPLNE DTS 5	1	2
24	ROBOT KUKA	KUKO 1420 HP	1	2
23	KOLIK 12-10-C	DIN 6321	2	2
22	KUZELOVY KOLIK 5x22	DIN 1	1	1
21	ROZLOZKA M4	DIN ISO 7092	6	1
20	MATICE M8	DIN 934	16	1
19	MATICE M5	DIN 934	6	1
18	MATICE M4	ISO 4035	16	1
17	SRUB M12x40	DIN 912	4	2
16	SRUB M8x40	DIN 912	14	2
15	SRUB M6x12	DIN 912	16	1
14	SRUB M6x16	DIN 912	6	1
13	SRUB M5x25	DIN 912	7	1
12	SRUB M4x20	DIN 912	4	1
11	SRUB M4x8	DIN 912	16	1
10	SKLICIDLO	PRT_008	1	2
9	OVERE	PRT_005	1	1
8	DESKA-HALDVERE	PRT_004	1	1
7	ODHANNY BOX	PRT_003	1	1
6	DRZAK	PRT_002	1	1
5	DESKA	PRT_001	1	2
4	KRYT-PRAVY	ASM_004	1	1
3	KRYT-LEVY	ASM_003	1	1
2	KRYT-DVERE	ASM_002	1	1
1	SP 430	SP_430	1	1

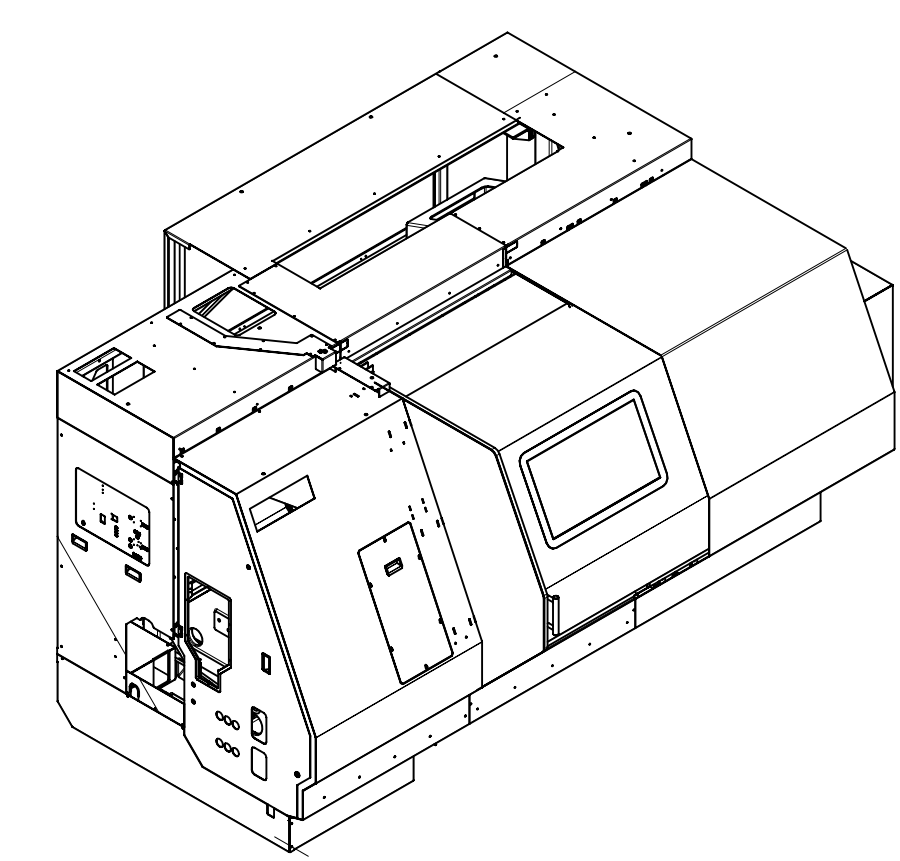

PROJEKTANT	1110	1118	1119	1120
PROJEKT	DP			
STATUS				
ALTERNATIVNI CÍSEL				

Výzkumné centrum
 pro dopravní výrobní techniku
 a robotiku

LASERPRINT SP 430
 CÍSEL VÝKRESU
 ASM_001

