



SAHC

Proposal of Measures for Preserving the Historical Fresco of the Assumption of the Virgin Mary by V.V.Reiner

Yasser Sidaoui

Czech Republic | 2 017



ADVANCED MASTERS IN STRUCTURAL ANALYSIS
OF MONUMENTS AND HISTORICAL CONSTRUCTIONS

Master's Thesis

Yasser Sidaoui

Proposal of Measures for
Preserving the Historical
Fresco of the Assumption
of the Virgin Mary by
V.V.Reiner



UNIVERSITAT POLITÈCNICA
DE CATALUNYA



Education and Culture

Erasmus Mundus



ADVANCED MASTERS IN STRUCTURAL ANALYSIS
OF MONUMENTS AND HISTORICAL CONSTRUCTIONS



Master's Thesis

Yasser Sidaoui

Proposal of Measures for
Preserving the Historical
Fresco of the Assumption
of the Virgin Mary by
V.V.Reiner

This Masters Course has been funded with support from the European Commission. This publication reflects the views only of the author, and the Commission cannot be held responsible for any use which may be made of the information contained therein.

This page is left blank on purpose.

DECLARATION

Name: Yasser Sidaoui

Email: yasser92s@hotmail.com

Title of the

Msc Dissertation: Proposal of Measures for Preserving the Historical Fresco of the Assumption of the Virgin Mary by V.V.Reiner

Supervisor(s): prof. Ing. Karel Kabele, CSc.

Year: 2016/2017

I hereby declare that all information in this document has been obtained and presented in accordance with academic rules and ethical conduct. I also declare that, as required by these rules and conduct, I have fully cited and referenced all material and results that are not original to this work.

I hereby declare that the MSc Consortium responsible for the Advanced Masters in Structural Analysis of Monuments and Historical Constructions is not allowed to store and make available electronically the present MSc Dissertation.

University: ČESKÉ VYSOKÉ UČENÍ TECHNICKÉ V PRAZE

Date: July 4 2017

Signature: _____



This page is left blank on purpose.



MASTER'S THESIS PROPOSAL

study programme: Civil Engineering
study branch: Advanced Masters in Structural Analysis of Monuments and Historical Constructions
academic year: 2016/2017

Student's name and surname: Yasser Sidaoui
Department: Department of Mechanics
Thesis supervisor: prof. Ing. Karel Kabele, CSc.
Thesis title: Proposal of Measures for Preserving the Historical Fresco of the Assumption of the Virgin Mary by V.V. Reiner
Thesis title in English: see above

Framework content: - Assessing the current condition of the fresco pavilion and the extent of condensation

- Proposals for the use of pavilion with fresco

- Determining the appropriate temperature and humidity parameters of the indoor environment with regard to the current condition and the newly designed function and in particular the preservation of historical fresco

- Comparison of the energy demand between the current condition & the newly designed function

- Comparison of the energy cost between different energy sources

Assignment date: 7/04/2017 Submission date: 06/07/2017

If the student fails to submit the Master's thesis on time, they are obliged to justify this fact in advance in writing, if this request (submitted through the Student Registrar) is granted by the Dean, the Dean will assign the student a substitute date for holding the final graduation examination (2 attempts for FGE remain). If this fact is not appropriately excused or if the request is not granted by the Dean, the Dean will assign the student a date for retaking the final graduation examination, FGE can be retaken only once. (Study and Examination Code, Art 22, Par 3, 4.)

The student takes notice of the obligation of working out the Master's thesis on their own, without any outside help, except for consultation. The list of references, other sources and names of consultants must be included in the Master's thesis.

Master's thesis supervisor

Head of department

Date of Master's thesis proposal take over: July 2017

Student

This form must be completed in 3 copies – 1x department, 1x student, 1x Student Registrar (sent by department)

No later than by the end of the 2nd week of instruction in the semester, the department shall send one copy of BT Proposal to the Student Registrar and enter data into the faculty information system KOS.
(Dean's Instruction for Implementation of Study Programmes and FGE at FCE CTU Art. 5, Par. 7)

To my great and loving parents, my soul sister, my childhood
frenemy, and the apple of my eye

This page is left blank on purpose.

Acknowledgements

This research project was completed within the framework of SAHC at the University Of Czech Technical University Of Prague under the supervision of Professor Karel Kabele, and Ing.arch Michala Balounova. Professor Kabele was such an awesome supervisor inspiring hard work and diligence. Despite his extremely busy schedule, he always found the time to meet and provide unparalleled guidance and expertise that aided in bringing this thesis to light. To Ms.Balounova, I will always be indebted to your constant support through the phase of this project by answering my numerous questions and providing help repeatedly. The author acknowledges the partial scholarship granted by the SAHC consortium that made my attendance to this program possible. The author also acknowledges the wonderful memories created by the great SACHers of 2016/2017.

I would like extend a sincere gratitude to my Catalan family: Albert, Carmen, Martina, and Cai, for their support and the wonderful memories we shared together. My conversations with Albert have broadened my perspectives of this world. Carmen, I will forever be indebted to the kindness you showed me.

Last but not least, I would like to acknowledge the unconditional love, and unlimited support provided by my wonderful immediate and extended family; first and foremost, my lovely parents and siblings. I'm also extremely grateful to my Uncles (M. B. A. W. H.), and Aunt (J.). I'm blessed to be surrounded by such loving people.

This page is left blank on purpose.

Abstract

The historical fresco of the Assumption of the Virgin Mary by V.V. Reiner was removed and deposited, after the demolition of the chapel, in the castle park in Duchcov in 1956. The newly constructed pavilion, however, is designed as semi-open space with extensive exposure to exterior climatic conditions. The fresco is directly affected by significant air temperature fluctuations, and high relative humidity. Such climatic conditions are known to be detrimental to historical frescos. The micro-climate of the pavilion was assessed to determine the extent of the condensation rate under two main occupancy conditions: unoccupied, and occupied. It was determined that condensation occurred during the winter and spring months only for the unoccupied function; while the occupied had condensation occurring during the winter, spring, and summer months. In order to prevent this condensation from occurring, an HVAC system was proposed to control the micro-climate inside the pavilion. For the unoccupied function, it was determined that maintaining a minimum temperature of 10°C is sufficient for 100% elimination of condensation. On other hand, the occupied function required dehumidification capabilities, in addition to maintaining a minimum temperature, for 100% elimination. The micro-climate temperature was kept at 15°C with 60% dehumidification set point. The energy demand is plotted for both occupancy functions, and a comparison of the cost between two different energy sources is provided.

This page is left blank on purpose.

Resumé

V zámku Duchcov byl v r. 1956 zbořen Hospital s kaplí s freskou Nanebevzetí Panny Marie od V. V. Reinera. Freska byla sňata a 25 let deponována až do roku 1985, kdy byla znovu položena do nově vybudovaného pavilonu v zámeckém parku. Nový pavilon v brutalistním stylu je však navržen jako částečně otevřený prostor, který je velmi ovlivňován vnějšími klimatickými podmínkami. Freska je tak přímo ovlivněna výraznými výkyvy teplot vzduchu a vysokou relativní vlhkostí, které vedou k poničení fresky.

Cílem této práce je stanovit podmínky vnitřního mikroklima v pavilonu pomocí numerického modelu a navrhnout opatření, která by vedla k eliminaci kondenzace na historické fresce. Vyhodnocení bylo provedeno ve dvou podmínkách: pro obsazený a neobsazený pavilon návštěvníky. V případě situace bez osob v pavilonu vykázaly výsledky numerické simulace kondenzaci na fresce během zimního a letního období, zatímco v případě otevření objektu návštěvníkům byla zjištěna kondenzace v průběhu celého roku. Jako opatření eliminující kondenzaci na fresce byl navržen systém HVAC. V případě neobsazeného pavilonu stačilo temperování na 10°C pro 100% eliminaci kondenzace, na druhou stranu obsazený objekt vykazoval kondenzaci i při 15°C, proto bylo navrženo odvlhčování. Pro oba případy byly vyhodnoceny dopady na spotřebu energie a s tím související náklady na provoz systému.

This page is left blank on purpose.

Table of Contents

| | |
|---|------|
| Acknowledgements..... | ix |
| Abstract..... | xi |
| Resumé | xiii |
| Table of Contents..... | xv |
| List of Figures | xvi |
| List of Tables | xvii |
| 1. Introduction | 1 |
| 1.1 Fresco Preservation..... | 1 |
| 1.2 Background Information..... | 3 |
| 2. Theoretical Analysis | 7 |
| 2.1 Condensation in Historical Constructions..... | 7 |
| 3. Numerical Analysis..... | 9 |
| 3.1 Model Creation | 9 |
| 3.2 Energy Performance & Occupancy | 11 |
| 3.2.1 Unoccupied | 11 |
| 3.2.2 Occupied | 11 |
| 3.3 HVAC System..... | 11 |
| 3.4 Software Outputs..... | 12 |
| 4. Results..... | 13 |
| 4.1 Condensation Rate..... | 13 |
| 4.1.1 Unoccupied | 13 |
| 4.1.2 Occupied | 15 |
| 4.2 Relative Humidity..... | 18 |
| 4.3 Energy Demand..... | 19 |
| 5. Discussion..... | 21 |
| 5.1 Condensation Rate..... | 21 |
| 5.2 Performance Index..... | 22 |
| 5.2.1 Unoccupied | 22 |

| | | |
|-------|------------------------|----|
| 5.2.2 | Occupied | 25 |
| 5.3 | Relative Humidity..... | 28 |
| 5.4 | Energy Demand..... | 30 |
| 6. | Conclusion..... | 33 |
| 7. | References | 35 |

List of Figures

| | | |
|-----------|--|----|
| Figure 1 | Duchcov Pavilion | 3 |
| Figure 2 | The assumption of the Virgin Mary Fresco | 3 |
| Figure 3 | Pavilion plan layout..... | 4 |
| Figure 4 | Pavilion elevation layout..... | 4 |
| Figure 5 | Roof ventilation hole..... | 4 |
| Figure 6 | Fresco dome ventilation opening | 4 |
| Figure 7 | Side ventilation opening | 5 |
| Figure 8 | Double-glazed windows..... | 5 |
| Figure 9 | Psychometric Chart | 8 |
| Figure 10 | Axonometric view of the model..... | 9 |
| Figure 11 | Fresco dome inside the roof | 9 |
| Figure 12 | Plan view of the model | 9 |
| Figure 13 | Zone 1..... | 10 |
| Figure 14 | Inner dome zone | 10 |
| Figure 15 | Pavilion roof | 10 |
| Figure 16 | Rate of condensation unoccupied (no heating)..... | 13 |
| Figure 17 | Rate of condensation unoccupied (5C)..... | 13 |
| Figure 18 | Rate of condensation unoccupied (10C)..... | 14 |
| Figure 19 | Rate of condensation occupied (no heating)..... | 15 |
| Figure 20 | Rate of condensation occupied (5C) | 15 |
| Figure 21 | Rate of condensation occupied (10C) | 16 |
| Figure 22 | Rate of condensation occupied (15C) | 16 |
| Figure 23 | Rate of condensation occupied (15C+Dehumidify) | 17 |
| Figure 24 | Energy demand (unoccupied) | 19 |
| Figure 25 | Energy demand (occupied) | 19 |
| Figure 26 | PI unoccupied no heating (winter)..... | 22 |
| Figure 27 | PI unoccupied no heating (spring) | 23 |
| Figure 28 | PI unoccupied no heating (summer)..... | 23 |
| Figure 29 | PI unoccupied 10C (winter)..... | 24 |
| Figure 30 | PI unoccupied 10C (spring) | 24 |
| Figure 31 | PI unoccupied 10C (summer)..... | 25 |
| Figure 32 | PI occupied no heating (winter)..... | 25 |

| | |
|---|----|
| Figure 33 PI occupied no heating (spring) | 26 |
| Figure 34 PI occupied no heating (summer) | 26 |
| Figure 35 PI occupied 15C (winter) | 27 |
| Figure 36 PI occupied 15C (spring)..... | 27 |
| Figure 37 PI occupied 15C (summer) | 28 |
| Figure 38 RH unoccupied vs. occupied (no heating)..... | 28 |
| Figure 39 RH unoccupied vs. occupied (no condensation) | 29 |
| Figure 40 Relative humidity Occupied (15Cvs15C+Dehumidify) | 30 |
| Figure 41 energy demand unoccupied (10C)..... | 30 |
| Figure 42 Energy demand occupied (15C+Dehumidify) | 31 |
| Figure 43 Energy breakdown Occupied (15C+Dehumidify)..... | 32 |
| Figure 44 Economical option for eliminating condensation Occupied (15C+Dehumidify)..... | 32 |

List of Tables

| | |
|--|----|
| Table 1 Temperature & Relative humidity specifications for collections | 2 |
| Table 2 Unoccupied rate of condensation..... | 14 |
| Table 3 Occupied rate of condensation | 17 |
| Table 4 Relative humidity (unoccupied) | 18 |
| Table 5 Relative humidity (occupied) | 18 |
| Table 6 Cost of fuel consumption | 31 |

1. Introduction

1.1 Fresco Preservation

Appreciating humanity's history and diverse culture dictates preserving objects of cultural significance. This importance stems from the sentimental value an object holds, its aesthetics, social, or monetary value. Sometimes, it is difficult to estimate the true value of a monument or an object that has been around for years, and that has slowly become an undetached part of society. Historical pieces are vulnerable against many threats, and hence the steps taken to preserve them are sometimes extravagant. In most cases, catastrophes such as the destruction of certain objects could be avoided by routine maintenance. That being said, it is necessary to sometimes interfere and take on more risk. The ideal condition of a historic object is usually a compromise between a perfectly applied theoretical environment and a practical one. It is true that the deterioration process of certain historical objects could be drastically halted, however by doing that we are significantly limiting the usage of the object, and detaching it from the society. For example, the best practice to preserve a painting is to lock it away in a dark temperature-controlled box that will prevent any mold attacks, and disintegration; however, doing so will conflict with the function of the painting. The painting is meant to be displayed in a gallery where people can view it, admire it, and reflect on the story this painting is telling. [1]

In general, the building's design and HVAC (heating, ventilation, and air conditioning) system should protect against eight types of threats. Those being: light damage; relative humidity; temperature; pest infestation; shock & vibration; natural emergencies; building and mechanical design malfunctions; and theft and vandalism [1]. For the Duchcov's fresco (to be introduced in the next section), the only points of interest are the relative humidity, and temperature. High relative humidity is directly correlated with accelerated mold growth on most surfaces, and chemical deterioration [1]. The fluctuation of relative humidity is also known to cause mechanical damage. There is not one condition that is perfect for preserving all historical objects, as no two collections are identical. However, the consensus is that to prevent condensation, the temperature and humidity must be controlled. Usually the perfect condition is set collaboratively by professionals with in-depth knowledge of the piece being preserved, and the damage patterns associated with it. This approach guarantees to provide the maximum life expectancy of historical objects.

The fresco is an old artistic technique that dates back as early as 1700B.C. [2]. The most common chemicals used in Frescos are: SiO_2 (silicon dioxide); CaO (calcium oxide); H_2O (dihydrogen oxide); $\text{Ca}(\text{OH})_2$ (calcium hydroxide); CO_2 (carbon dioxide); and CaCO_3 (calcium carbonate) [2]. In everyday's terminology, those materials are: sand, quicklime, water, slaked lime, air, and limestone respectively. Water is known to seep through, and expand in colder climates. The specifications for different protecting classes for historical collections are presented in Table 1, which was taken from the ASHRAE Handbook of HVAC applications.

Table 1 Temperature & Relative humidity specifications for collections [1]

| Type | Set Point or Annual Average | Maximum Fluctuations and Gradients in Controlled Spaces | | | Collection Risks and Benefits |
|---|--|---|--|---|---|
| | | Class of Control | Short Fluctuations plus Space Gradients | Seasonal Adjustments in System Set Point | |
| General Museums, Art Galleries, Libraries, and Archives | 50% RH (or historic annual average for permanent collections) | AA Precision control, no seasonal changes, with system failure fallback | ±5% RH, ±2K | Relative humidity no change Up 5K, down 5K | No risk of mechanical damage to most artifacts and paintings. Some metals and minerals may degrade if 50% RH exceeds critical relative humidity. Chemically unstable objects unstable within decades. |
| | Temperature Set between 15 and 25°C Note: Rooms intended for loan exhibitions must handle set point specified in loan agreement, typically 50% RH, 21°C, but sometimes 55% or 60% RH. | A Precision control, some gradients or seasonal changes, not both, with system failure fallback | ±5% RH, ±2K | Up 10% RH, down 10% RH Up 5K, down 10K | Small risk of mechanical damage to high-vulnerability artifacts; no mechanical risk to most artifacts, paintings, photographs, and books. Chemically unstable objects unstable within decades. |
| | | | ±10% RH, ±2K | RH no change Up 5K, down 10K | |
| | | B Precision control, some gradients plus winter temperature setback | ±10% RH, ±5K | Up 10% RH, down 10% RH Up 10K, but not above 30°C | Moderate risk of mechanical damage to high-vulnerability artifacts; tiny risk to most paintings, most photographs, some artifacts, some books; no risk to many artifacts and most books. Chemically unstable objects unstable within decades, less if routinely at 30°C, but cold winter periods double life. |
| | | C Prevent all high-risk extremes | Within 25 to 75% RH year-round Temperature rarely over 30°C Usually below 25°C | | High risk of mechanical damage to high-vulnerability artifacts; moderate risk to most paintings, most photographs, some artifacts, some books; tiny risk to many artifacts and most books. Chemically unstable objects unstable within decades, less if routinely at 30°C, but cold winter periods double life. |
| | D Prevent dampness | Reliably below 75% RH | | High risk of sudden or cumulative mechanical damage to most artifacts and paintings because of low-humidity fracture; but avoids high-humidity delamination and deformations, especially in veneers, paintings, paper, and photographs. Mold growth and rapid corrosion avoided. Chemically unstable objects unstable within decades, less if routinely at 30°C, but cold winter periods double life. | |

1.2 Background Information

The infamous historical fresco of the Assumption of the Virgin Mary (Nanebevzeti Panny Marie) was commissioned in the 18th century, and completed by V.V. Reiner [3]. The fresco originally decorated the dome of the hospital church of the assumption of the Virgin Mary [4]. The hospital was demolished in 1958; however, the fresco was moved 2 years prior to the demolition [3]. Fragments from the fresco were exhibited in 1967 at the World Expo in Montreal [3].

In 1973, architect Jana Sokola started the construction of a new exhibition hall in the architectural style of Brutalist [3]. This newly constructed pavilion is located in the castle gardens in Duchcov. **Error! Reference source not found.** [5] shows the newly constructed pavilion.

The pavilion is mainly constructed with reinforced concrete. The building's walls are

made of 20cm thick concrete walls. There are two large double-glazed translucent windows on the north-eastern façade, and the south-western façade. The roof of the building consists of triangular extrusions covered with metallic cladding on the exterior, and timber framing on the interior. There's a small ventilation hole in the middle of the roof. Within this roof, there's a smaller elliptical concrete dome. The fresco fragments are installed on this smaller concrete dome as shown in **Error! Reference source not found.**. The small dome has 5 ventilation openings. Figure 3, and Figure 4, show the plan, and elevation layouts of the pavilion.



Figure 1 Duchcov Pavilion

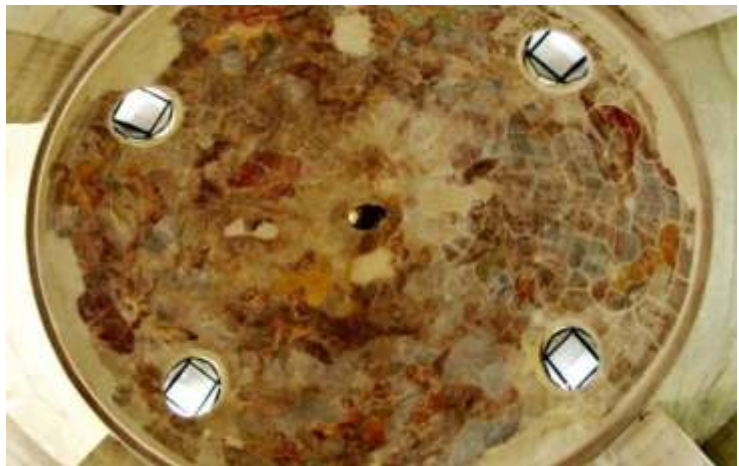

Figure 2 The assumption of the Virgin Mary Fresco

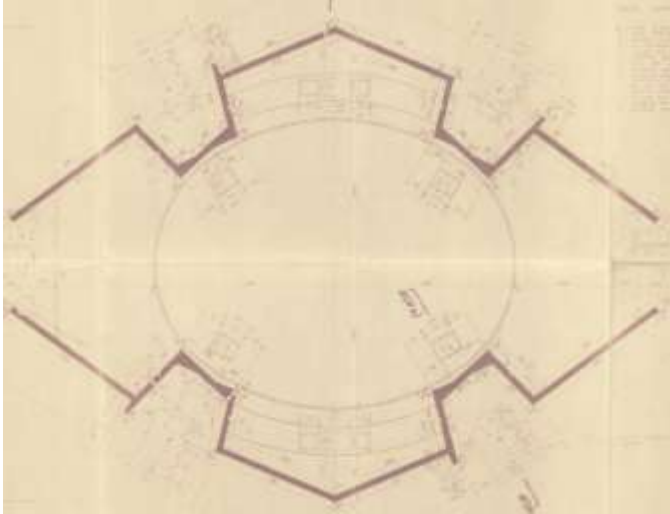

Figure 3 Pavilion plan layout

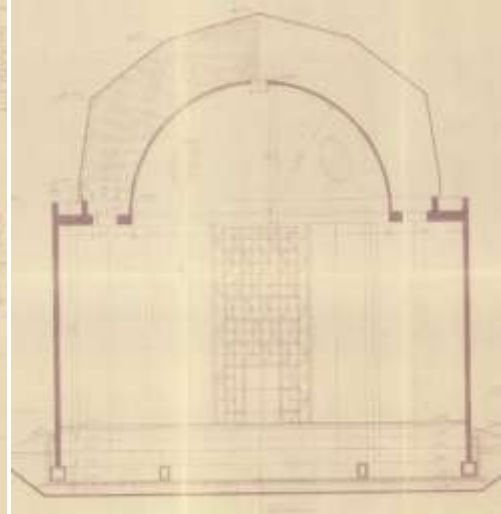

Figure 4 Pavilion elevation layout

The fresco's condition is deteriorating due to excessive condensation [6]. As most historical buildings, the pavilion does not have any HVAC system which aggravates the problem further. Initially, the pavilion was designed with several ventilation vents to mitigate humidity issues. As mentioned previously, there are 5 openings in the small dome, and one opening in the roof. In addition, there are two large arch-shaped openings between the smaller dome and the roof. Figure 5 shows the ventilation hole in the middle of the roof.



Figure 5 Roof ventilation hole



Figure 6 Fresco dome ventilation opening

Figure 6 shows the backside of one of the large ventilation openings in the fresco dome.

Figure 7 shows the part of the two large side openings. Also shown in the picture is the piece of cloth that is used to cover the opening as it later was determined that said openings aggravate the conditions inside the building.

Due to said condensation concerns, the pavilion is not currently open to the public. Some restoration works have been carried in the past couple of years to reduce the effect of moisture. The windows were changed to make the building more airtight. Currently, the pavilion is under monitoring, with further restoration works planned for 2018 and 2019 [6].



Figure 7 Side ventilation opening

Figure 8 shows the double-glazed windows.

The main purpose of this thesis is to create a model of the pavilion that will give a clear indication of the energy performance of the building, and estimate the energy required to eliminate the condensation problem. First of all, the current occupancy of the building will be modelled to determine the rate of condensation. Once that is determined, measures will be applied to enhance the buildings energy performance, and to check whether the measures are beneficial. The next step would be to heat the building through the installation of an HVAC system. Maintaining a minimum temperature is one approach to implement that. The goal would be to determine what that minimum temperature would be. Another way to tackle the issue is to combine maintaining a minimum temperature, and dehumidification process to lower the relative humidity within the building. As far as this report is concerned, the winter term used in this report refers to the months of October, November, December, January, and February; spring refers to the months of March, April, May, and June; and summer refers to the months of July, August, and September.



Figure 8 Double-glazed windows

2. Theoretical Analysis

2.1 Condensation in Historical Constructions

Knowledge of the deteriorating processes affecting cultural objects is absolutely necessary when trying to determine the appropriate conservation measures. Cultural objects exchange heat & moisture with the indoor air. This exchange is dictated by the outdoor environmental conditions, as long as there is no HVAC system in place. The exchange between the indoor micro-climate and the outdoors conditions is usually what aggravates the issues pertaining to historical objects. In the case of Fresco preservation, there needs to be some sort of control over the fluctuations over surface temperatures [1]. These fluctuations combined with the exterior changes in air temperature results in condensation. The problem of condensation is usually prevailing in the spring months, but is also common in other times of the year [7]. This is governed by the occupancy usage of the building, the materials used in construction, and last but not least the geographic location (i.e climatic conditions).

Condensation is the process where water vapor becomes liquid [8]. The condensation phenomenon is normally triggered by two reasons. Either the air is cooled to its dew point temperature, or it becomes fully saturated that it cannot hold any more water vapor [8]. The dew point temperature is the point at which the air can no longer hold the water vapor within it and some of the vapor must transform into liquid state [9]. This usually occurs at night when the air temperatures cools down and appears on cars, windows, etc. Condensation also appears when warm air passes a cooler surface; the surface then drops the temperature of the air below its dew point, thus creating condensation [8]. The dew point temperature is determined using the psychrometric chart (shown in Figure 9 [10]). A psychrometric chart is usually used to figure out the temperature (wet bulb & dry bulb), and humidity. The chart's main purpose is, hence, to interpret the occupants' comfort and effective passive design [10]. The horizontal axis represents the temperature (in °C), the vertical axis represents the moisture content (in kg/kg dry air), and the colored curves represent the different relative humidity levels [10]. Diagonal lines on the chart also represent Enthalpy (total heat content of the system) at saturation.

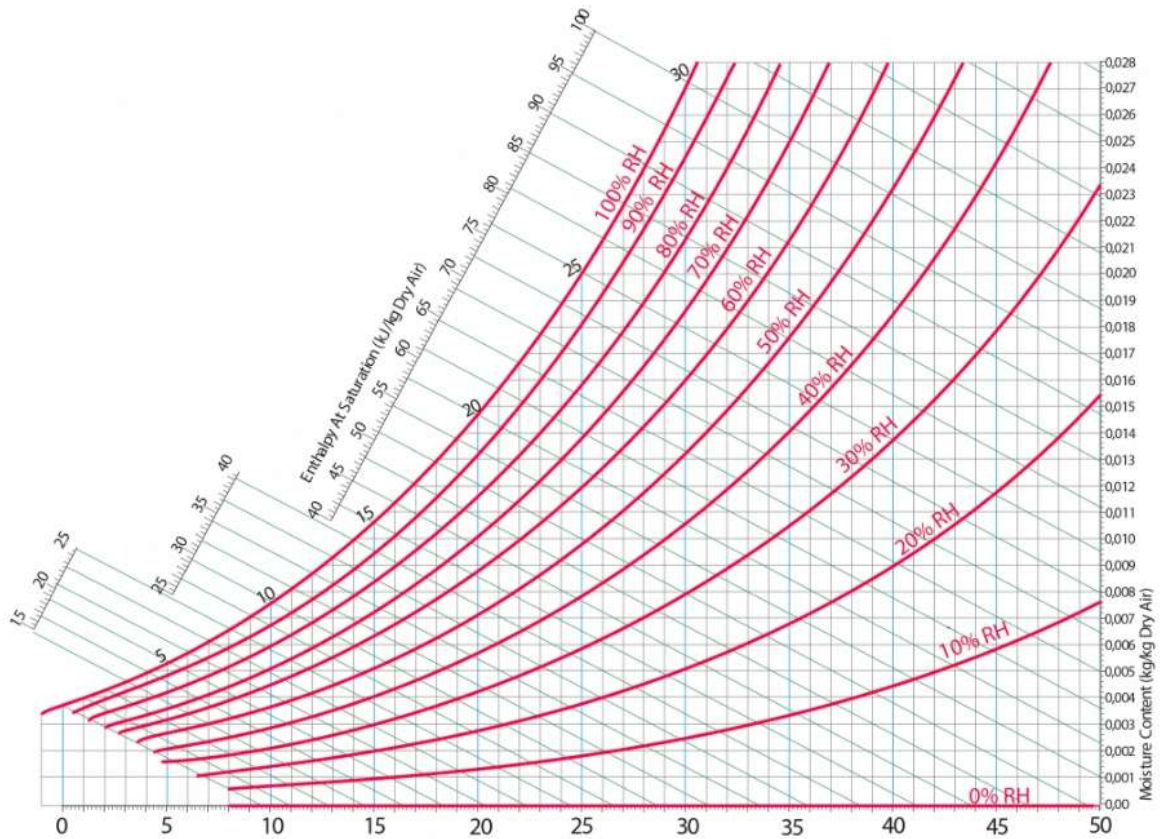

Figure 9 Psychrometric Chart

In order to determine the dew point temperature, both the air temperature, and relative humidity are needed first. Once those values are obtained, they are plotted on the above chart. A horizontal line is then drawn. The point at which the line crosses the 100% relative humidity curve is known as the dew point temperature. The chart provides a good approximation of the dew point temperature. For more precise calculations, the following formula [11] can be used:

$$T_d = \left(\frac{RH}{100} \right)^{\frac{1}{3}} * (112 + 0.9T) + 0.1T - 112$$

Where,

T_d : Dew point temperature

RH: relative humidity in percentage

T: Air temperature

3. Numerical Analysis

3.1 Model Creation

The pavilion is modeled using Design Builder Software Package. The software consists of a 3-D modeller and 10 modules that work in conjunction to thoroughly analyze any building [12]. The software combines modelling technology with advanced energy simulation so that professionals can reduce a building's impact on the environment [12]. The software has a large database of numerous weather data. The software also has a massive materials database that contains the properties of countless building materials.

The 3D model was created as per the exact dimensions of the pavilion. The triangular extrusions roof was modelled as an outer dome to simplify the processing. Figure 10, and Figure 12 shows the axonometric and plan layouts respectively. Figure 11 illustrates how the roof and the fresco dome were modelled. The concrete sections of the buildings were set at 20cm thickness. The exterior dome (roof) was created using (0.01m thickness) metal cladding, and (0.1m thickness) timber framing.

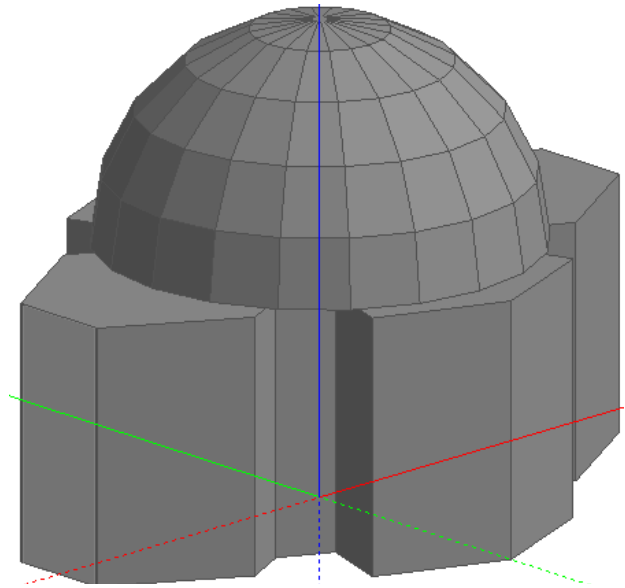

Figure 10 Axonometric view of the model

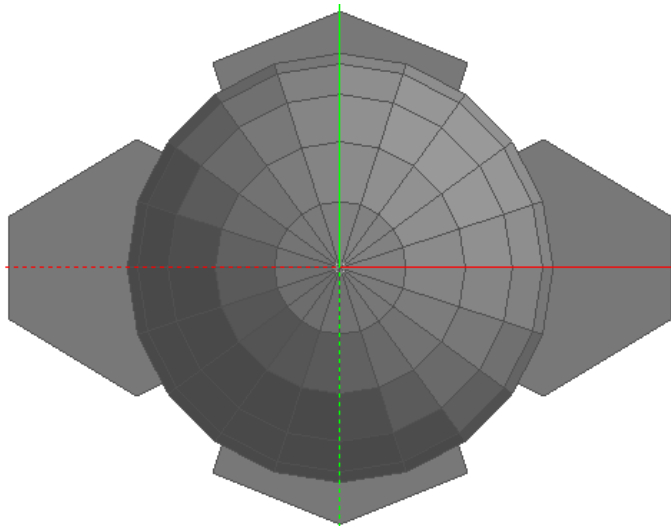

Figure 12 Plan view of the model

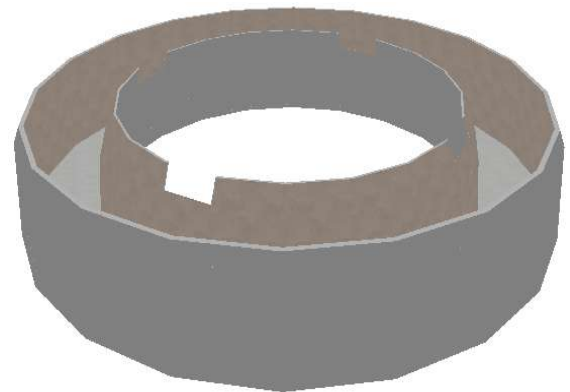

Figure 11 Fresco dome inside the roof

The different zones of the buildings are illustrated below. Figure 13 illustrates the plan layout of zone 1; this is the main zone of the pavilion. The large circle in the middle (highlighted in green), represent the border of the inner dome, where the fresco is placed. The two ventilation openings are also shown on the sides. Figure 14 shows the inner dome. There are four boxes, and small circle on top (all highlighted in green) that represent the openings inside and the inner dome for ventilation.

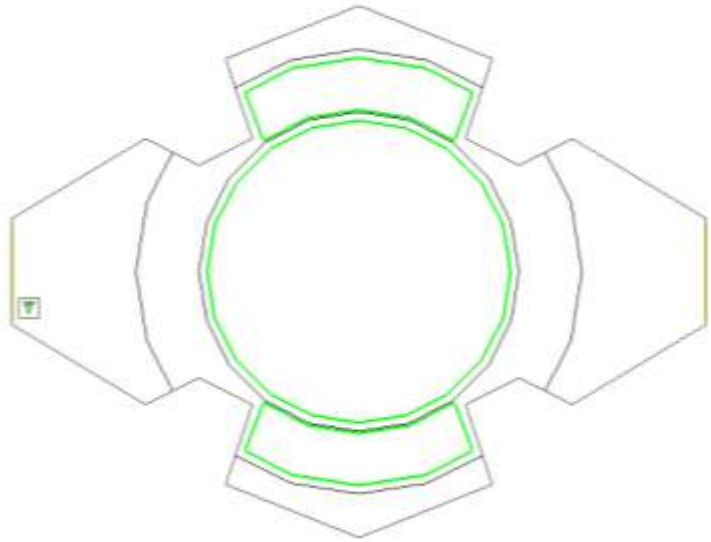

Figure 13 Zone 1

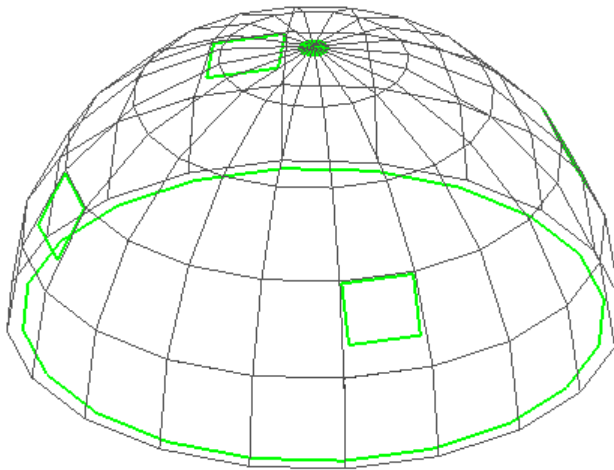

Figure 14 Inner dome zone

Figure 15 shows the triangular extrusion roof (modelled as an exterior dome). The two large ventilation openings highlighted in green are shown on the sides of the inner dome. There is also the small ventilation opening on the top of the roof for ventilation.

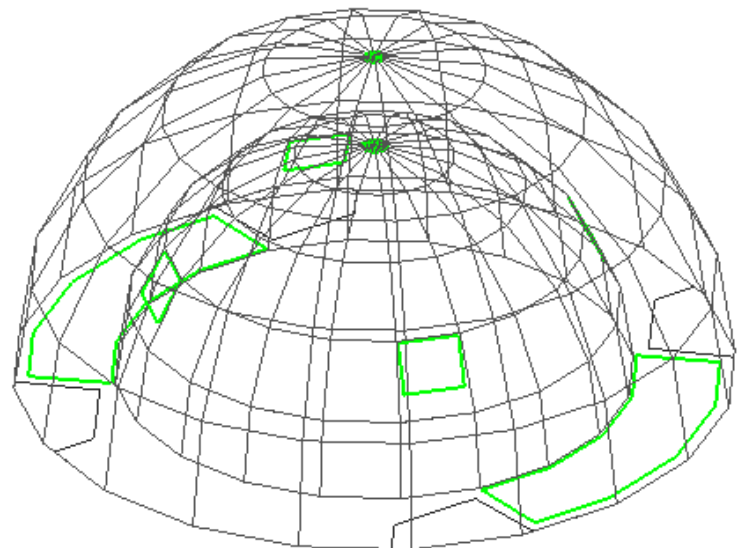

Figure 15 Pavilion roof

3.2 Energy Performance & Occupancy

The pavilion's energy performance is strongly correlated to its occupancy. The latter determines the type of activities that are normally taking place during a day, an evening, and weekends. By knowing the type of activity, internal gains can be assessed and incorporated in modelling the precise energy performance of a structure. When accounting for internal heat gains generated by occupants, the density of occupants and their metabolic rate are two of the most important factors to take into account. Such information is usually available to change within the modelling software. Most packages offer an extensive list of occupancy usages to choose from. The density of people and their metabolic rate can also be changed within the software package.

As it was explained in the introduction, the pavilion is currently not open to the public. However, it would be beneficial to model the building under different occupancy modes to better assess the energy performance in such conditions. Two main occupancy activities are created to predict the results of both an unoccupied and occupied functions.

3.2.1 Unoccupied

This is the current condition of the pavilion. It is assumed to be closed year-round. It must be noted that gains are close to null in such occupancy. In addition to no occupancy, there are no lightings in the pavilion. The translucent windows at the entrances keep the solar gains to the minimum, and lack of windows in the pavilion aids in that.

3.2.2 Occupied

This is to model the building in case it was decided to be opened to visitors interested in the fresco, and possibly other artworks by V.V. Reiner. The occupied activity would be similar to public circulation areas where people are walking around, and where display items are exhibited. Such categories are usually applied to libraries, museums, and galleries. The density of people is assumed 0.1497people/m^2 , which is roughly equivalent to 3.5W/m^2 of energy generated. This occupancy is scheduled from 10:00AM until 4:00PM five days a week. Similar to the unoccupied activity, gains from other sources such as solar gains and lightings are limited.

3.3 HVAC System

The best method to control indoor micro-climates in any historical structures is to use an HVAC system; whether the system consists of simple heating apparatuses, or a more robust system that offers dehumidification capabilities [13]. To try and mitigate the condensation issue, the structure was modelled with different scenarios for each occupancy type. The inside temperature of the structure was kept at 5°C , 10°C , and 15°C to test at which temperature the condensation would stop. In addition, dehumidification would be added when heating alone does not suffice to eliminate the condensation.

3.4 Software Outputs

The software warms up the pavilion based on the surrounding air temperature – taken from the historical climatic data – in order to mimic the actual real life climate. The results generated by the software can be customized to illustrate the desired results. For example, there are about 99 criteria to choose from. This includes, but not limited to, energy consumption; air & radiant temperatures; gains from different sources; relative humidity; mechanical & natural ventilation; surface temperatures; and much more.

The above mentioned criteria were generated for all sections of the pavilion (the pavilion as a whole, the main occupant zone, and the fresco dome) as illustrated under the ‘Model Creation’ section. As far as the scope of this thesis, the main criteria of interests are: energy demand for the pavilion; air temperature & relative humidity of the main occupant zone; and the surface temperature of the fresco dome. The air temperature and the relative humidity data is used to calculate the dew point temperature, which is then used in the comparison with the surface temperature to determine the condensation occurrence. Refer to section 2.1 for calculation steps. If the temperature taken from the fresco dome’s surface is lower than the calculated dew point temperature, condensation occurs. The data simulated by the software is generated hourly (i.e the above mentioned criteria are generated every single hour for the 365 days). Each simulation scenario (e.g unoccupied 5°C function) generates around 26,280 rows of excel data.

4. Results

4.1 Condensation Rate

4.1.1 Unoccupied

Figure 16, Figure 17, and Figure 18 show the cumulative number of condensation hours for the no heating, 5°C, and 10°C respectively.

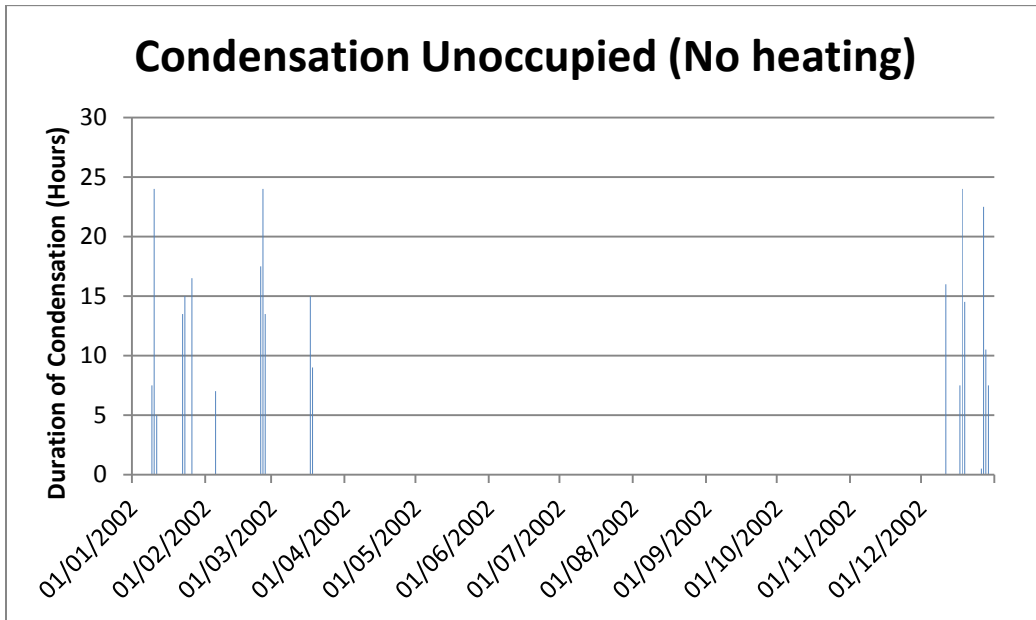

Figure 16 Rate of condensation unoccupied (no heating)

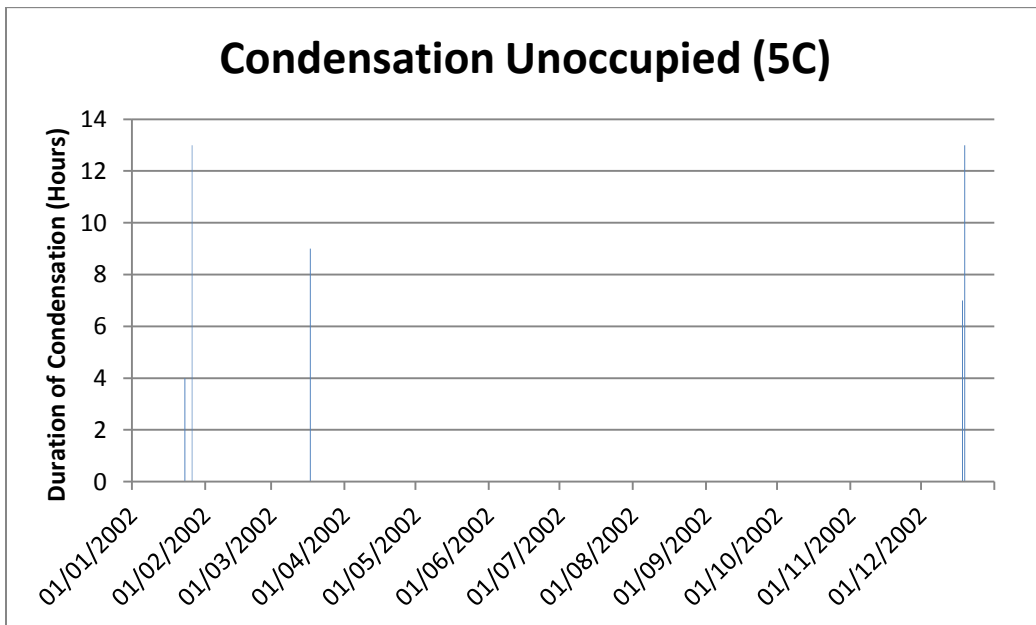

Figure 17 Rate of condensation unoccupied (5C)

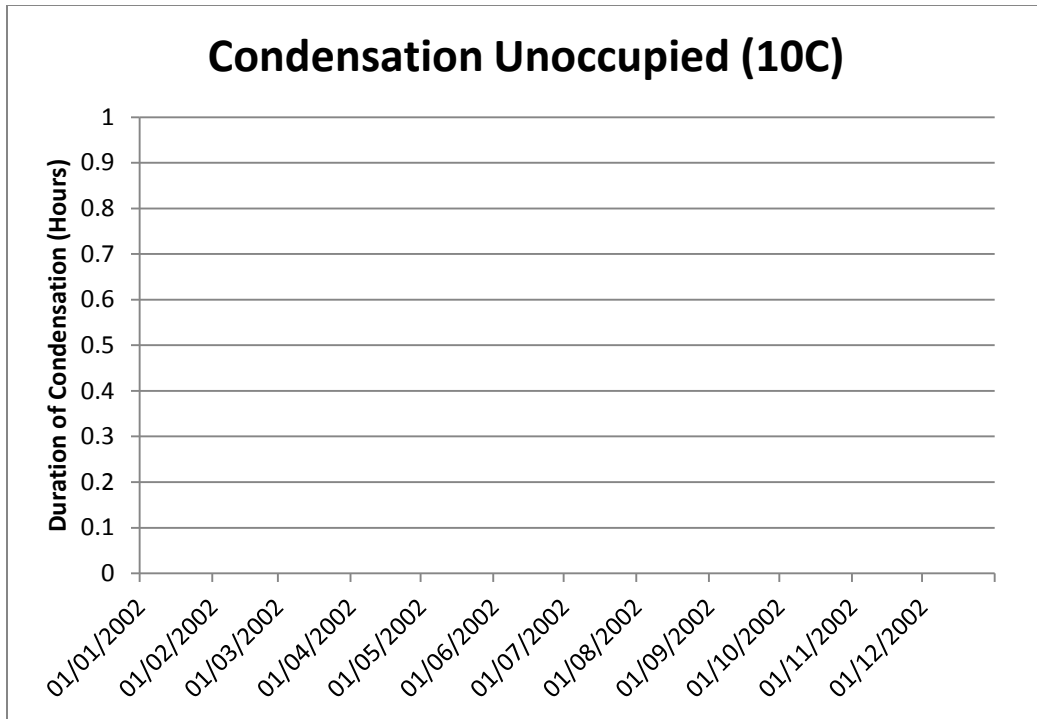

Figure 18 Rate of condensation unoccupied (10C)

Table 2 summarizes the rate of condensation for each month for all different scenarios.

Table 2 Unoccupied rate of condensation

| Month | Rate of Condensation (# of hours) | | |
|-----------|-----------------------------------|-----------------|------------------|
| | Unoccupied (No heating) | Unoccupied (5C) | Unoccupied (10C) |
| January | 80 | 17 | 0 |
| February | 50 | 0 | 0 |
| March | 24 | 9 | 0 |
| April | 0 | 0 | 0 |
| May | 0 | 0 | 0 |
| June | 0 | 0 | 0 |
| July | 0 | 0 | 0 |
| August | 0 | 0 | 0 |
| September | 0 | 0 | 0 |
| October | 0 | 0 | 0 |
| November | 0 | 0 | 0 |
| December | 103 | 20 | 0 |

4.1.2 Occupied

Figure 19, Figure 20, Figure 21, Figure 22, and Figure 23 show the cumulative number of condensation hours for the no heating, 5°C, 10°C, 15°C, and 15°C+dehumidify respectively.

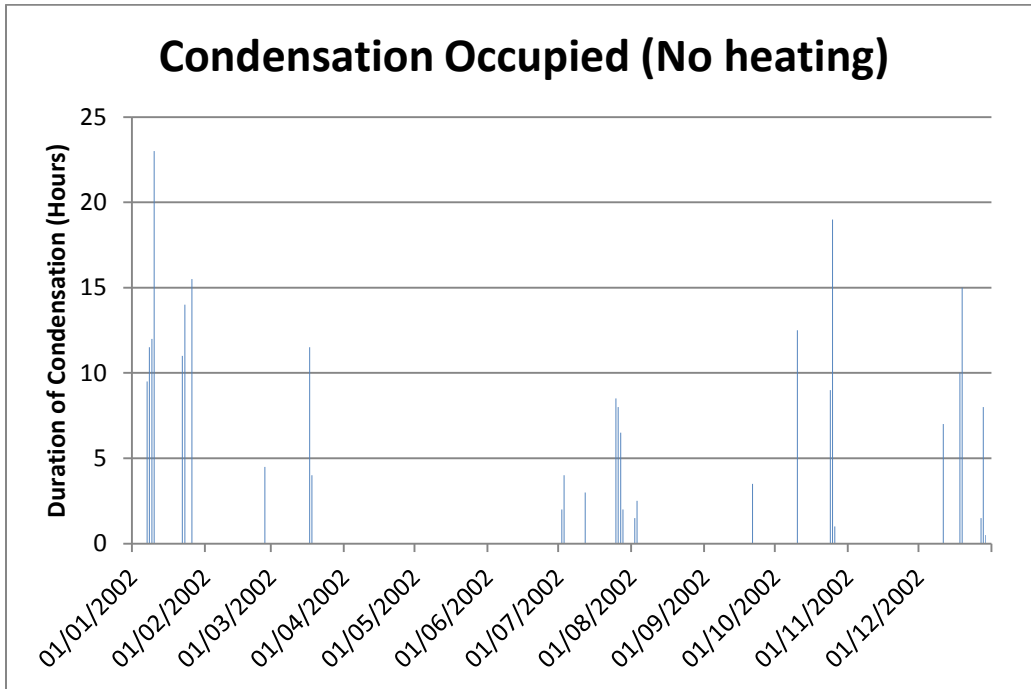

Figure 19 Rate of condensation occupied (no heating)

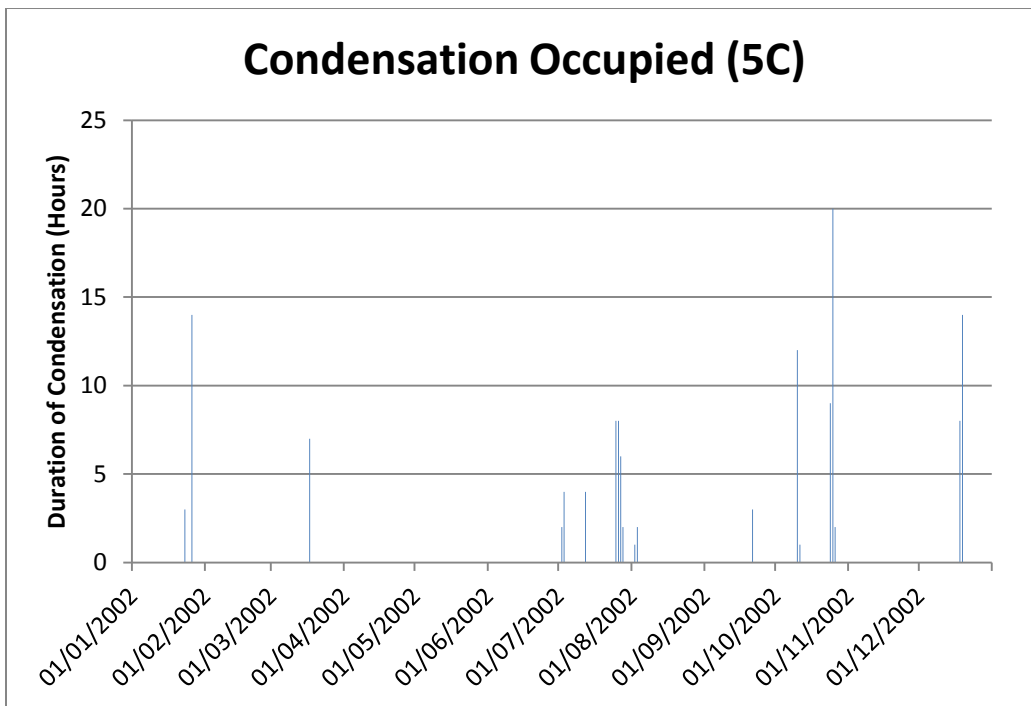

Figure 20 Rate of condensation occupied (5C)

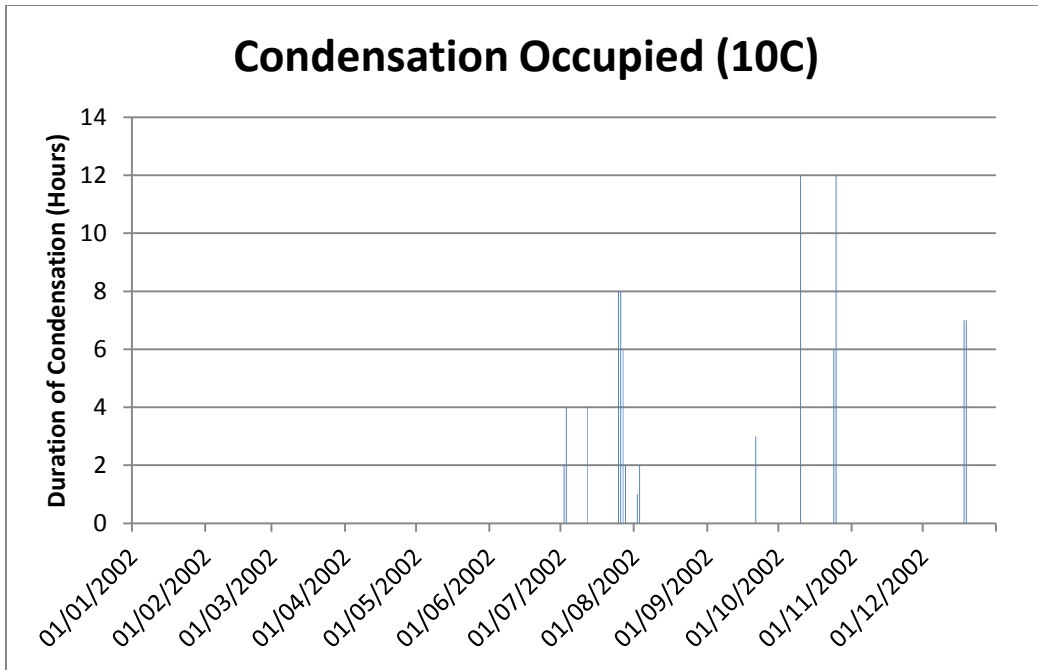

Figure 21 Rate of condensation occupied (10C)

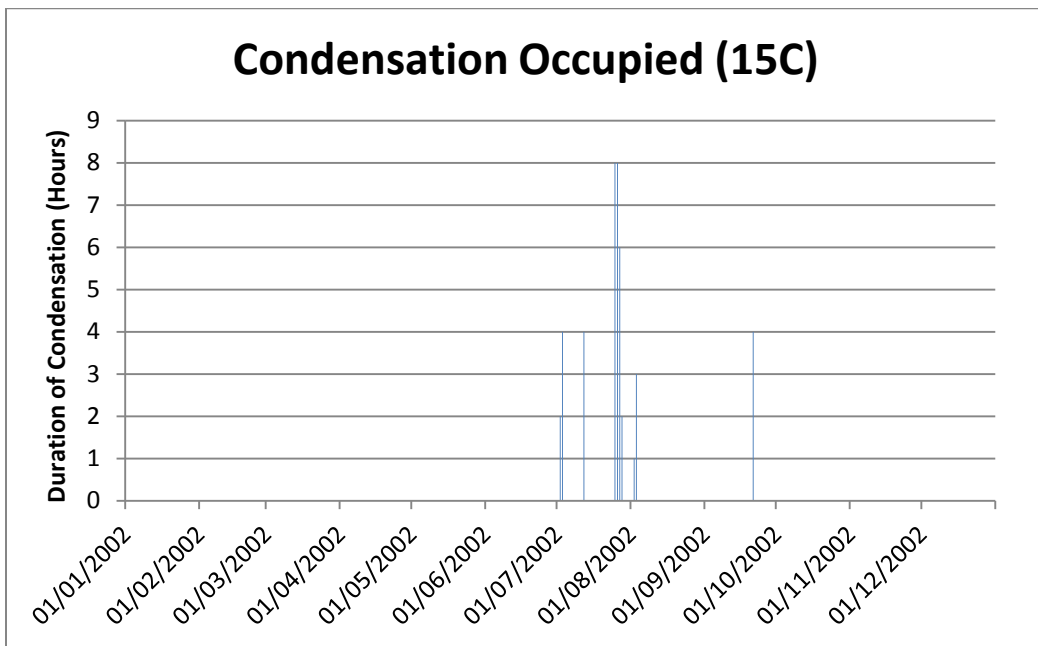

Figure 22 Rate of condensation occupied (15C)

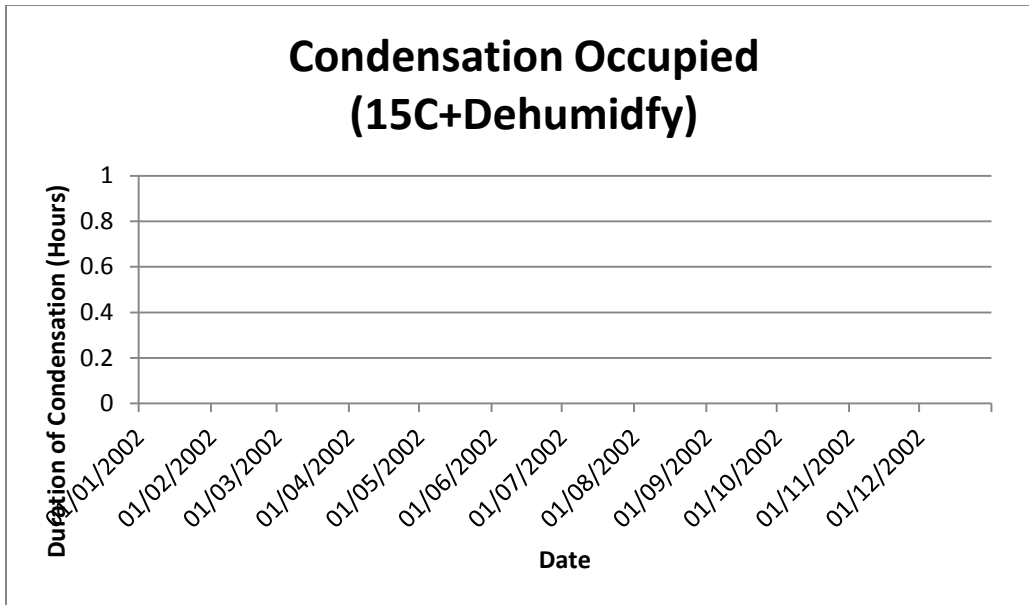

Figure 23 Rate of condensation occupied (15C+Dehumidfy)

Table 3 summarizes the rate of condensation for each month for all different scenarios.

Table 3 Occupied rate of condensation

| Month | Rate of Condensation (# of hours) | | | | |
|-----------|-----------------------------------|---------------|----------------|----------------|------------------------|
| | Occupied (No heating) | Occupied (5C) | Occupied (10C) | Occupied (15C) | Occupied (15C+Dehumid) |
| January | 96.5 | 17 | 0 | 0 | 0 |
| February | 4.5 | 0 | 0 | 0 | 0 |
| March | 15.5 | 7 | 0 | 0 | 0 |
| April | 0 | 0 | 0 | 0 | 0 |
| May | 0 | 0 | 0 | 0 | 0 |
| June | 0 | 0 | 0 | 0 | 0 |
| July | 34 | 34 | 34 | 34 | 0 |
| August | 4 | 3 | 3 | 3 | 0 |
| September | 3.5 | 3 | 3 | 3 | 0 |
| October | 41 | 41 | 30 | 0 | 0 |
| November | 0 | 0 | 0 | 0 | 0 |
| December | 42 | 22 | 14 | 0 | 0 |

4.2 Relative Humidity

Table 4 illustrates the monthly average relative humidity values for the unoccupied function.

Table 4 Relative humidity (unoccupied)

| Relative Humidity Unoccupied | | |
|-------------------------------------|---------------------|--------------|
| Month | (No heating) | (10C) |
| January | 82.02% | 38.23% |
| February | 77.81% | 38.60% |
| March | 64.06% | 44.17% |
| April | 57.47% | 51.16% |
| May | 54.31% | 53.72% |
| June | 61.32% | 62.21% |
| July | 56.75% | 58.20% |
| August | 60.06% | 58.47% |
| September | 64.59% | 66.63% |
| October | 76.09% | 64.30% |
| November | 79.26% | 51.39% |
| December | 85.71% | 48.66% |

Table 5 illustrates the monthly average relative humidity values for the occupied function.

Table 5 Relative humidity (occupied)

| Relative Humidity Occupied | | | |
|-----------------------------------|---------------------|--------------|------------------------|
| Month | (No heating) | (15C) | (15C+Dehumidfy) |
| January | 79.30% | 33.03% | 31.75% |
| February | 73.38% | 33.89% | 32.18% |
| March | 62.46% | 40.30% | 37.83% |
| April | 63.87% | 54.05% | 47.40% |
| May | 67.05% | 63.03% | 54.14% |
| June | 75.16% | 75.13% | 64.68% |
| July | 75.08% | 75.89% | 63.45% |
| August | 76.89% | 75.64% | 63.77% |
| September | 77.06% | 72.9% | 64.38% |
| October | 81.10% | 58.21% | 54.03% |
| November | 76.56% | 41.90% | 38.94% |
| December | 81.20% | 47.35% | 45.17% |

4.3 Energy Demand

Figure 24 illustrates the energy consumption for the unoccupied function.

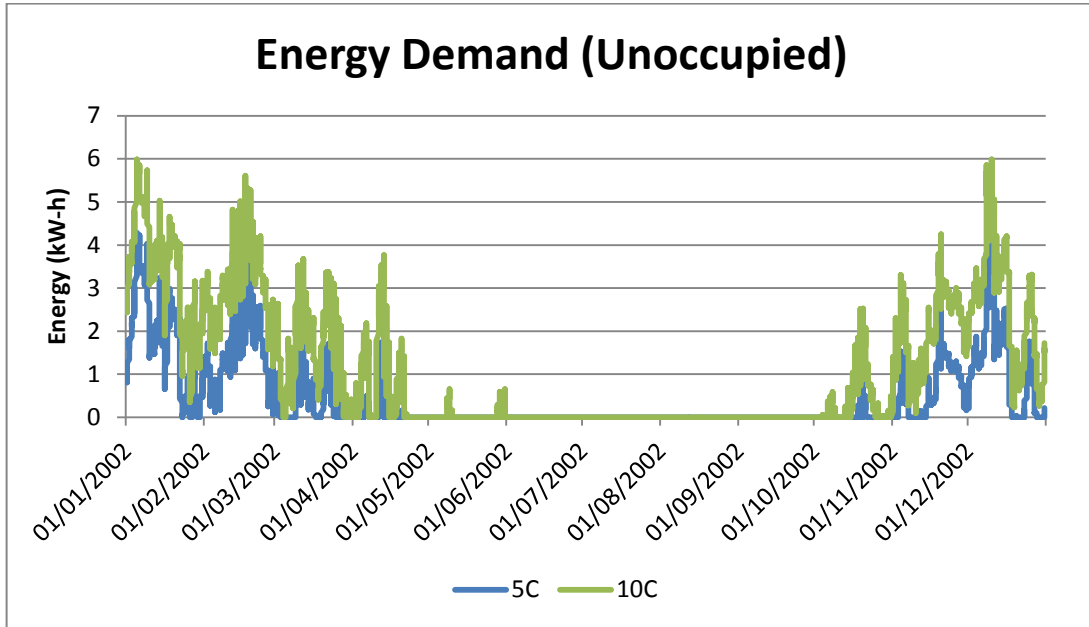

Figure 24 Energy demand (unoccupied)

Figure 25 illustrates the energy consumption for the occupied function.

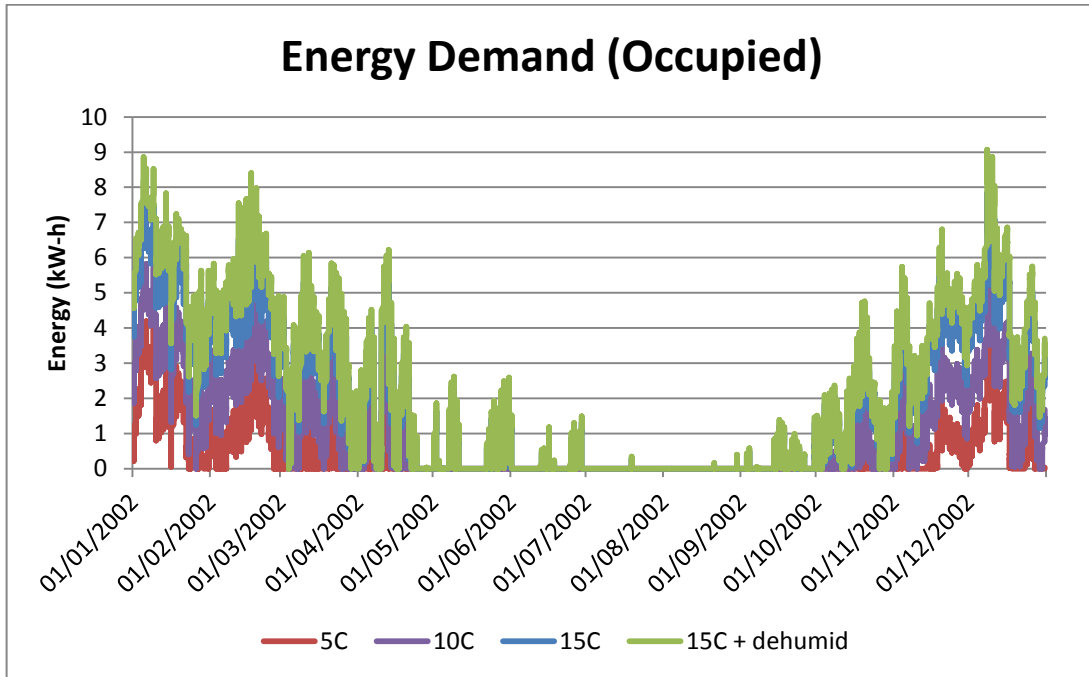

Figure 25 Energy demand (occupied)

5. Discussion

5.1 Condensation Rate

As shown in the graphs inserted under the results' section, for the unoccupied activity with no heating there is extensive condensation during the winter and beginning of spring months (December until March). December scored the highest condensation rate with a cumulative of 103 hours of condensation, followed by January, February, and March. Maintaining a temperature of 5°C in the building reduced the condensation by a factor of 5. The duration of condensation in the month of December dropped to 20 hours of cumulative condensation. Even with this drastic drop in condensation rate, 100% elimination was not achieved. By raising the temperature and maintaining a minimum of 10°C, condensation was completely eliminated in all months.

On the other hand, for the occupied activity, condensation occurred throughout the full year with few exceptions. This is expected as more humidity is introduced to the building with the presence of people. And since the building has very few openings for ventilation, the humidity is trapped within, thus raising the amount of water vapor carried by the indoor air. Similar to the unoccupied occupancy, the maximum condensation also occurred during the winter months with January scoring 96.5 hours of condensation, followed by October, and December. One plausible explanation of why the winter months end up with the highest condensation rate is the fact that low air temperatures result in low dew point temperatures, which means that much less water vapor is carried by indoor air. And since the relative humidity during the winter months exceed 75%, the dew point temperature is close to the actual air temperature, thus easily condensing on the surfaces.

A major difference between unoccupied and occupied functions, however, is that condensation occurred during the summer months in the case of occupied. July had the highest condensation rate with 34 hours of cumulative condensation. The reason for condensation occurring in the summer months is slightly different than condensation occurring during the winter, and spring months. The condensation in the winter, as it was previously explained, is attributed to low dew point temperatures. While the condensation during the spring months is attributed to the fact that air coming into the building is usually warmer than the surfaces that are still maintaining a fairly cool temperature from winter (refer to section 2.1 for further explanation) [14] [7]. This explains why when the building is heated to 5°C or 10°C, the condensation rate in the winter and spring months drops, while the condensation rate remains unaltered during the summer months. Condensation during the summer months is partially attributed to the fact that the late summer months are typically rainy, which means high outdoor humidity. Therefore, natural and mechanical ventilation does not really lower the condensation rate.

Maintaining a 5°C, and 10°C works effectively during the winter and spring months. The rate of condensation dropped drastically when building's temperature was kept at 5°C, and 10°C. The condensation rate for the months of January and December, for the occupied function, dropped by a factor of 2.5 and 5 respectively, when temperature was maintained at 5°C. The rate of condensation for the summer months remained as is, when temperature was maintained at 5°C.

Even when temperature was maintained at 10°C, the condensation rate barely changed for the month of October. Maintaining the temperature at 10°C, however, eliminated the condensation in some of the winter and spring months.

With still too much condensation occurring in five different months, the temperature was raised to 15°C. This raise eliminated all remaining condensation instances in all winter and spring months. It must be noted that with previous temperature raises, the condensation rate in the summer months remained untouched. This is due to the high humidity levels in both the indoor and outdoor climate as previously mentioned. To tackle this condensation, a dehumidification system was added to the model. It was determined that having a dehumidification set-point of 60% combined with maintaining a minimum temperature of 15°C eliminated the condensation completely in all months. It must be noted that the dehumidification system was set to work as per the exact schedule of the openings hours (i.e when occupancy is expected to rise). It is true that by doing so, the relative humidity will fluctuate and not be maintained at 60%. Yet, the average relative humidity values, as shown in section 5.3, dropped and the goal of eliminating condensation was achieved.

5.2 Performance Index

ASHRAE standards (listed under the introduction section) dictates that as per class A, the ideal condition for fresco is between 15°C and 25°C, and 40% and 60% relative humidity. For the sake of comparison, the PI (performance index) is plotted for both functions unoccupied and occupied (no heating); unoccupied (10°C) and occupied (15°C). PI is defined as the percentage of time in which the parameters lies within the (tolerance) parameters [14]. The graphs are plotted for three different ranges, winter, spring, and summer. Each dot on the graph represents the hourly value of temperature and relative humidity recorded for the whole year. The small box in the middle covering the values of class A represents 100% PI.

5.2.1 Unoccupied

Figure 26, Figure 27, and Figure 28 illustrate the PI index for the unoccupied (no heating).

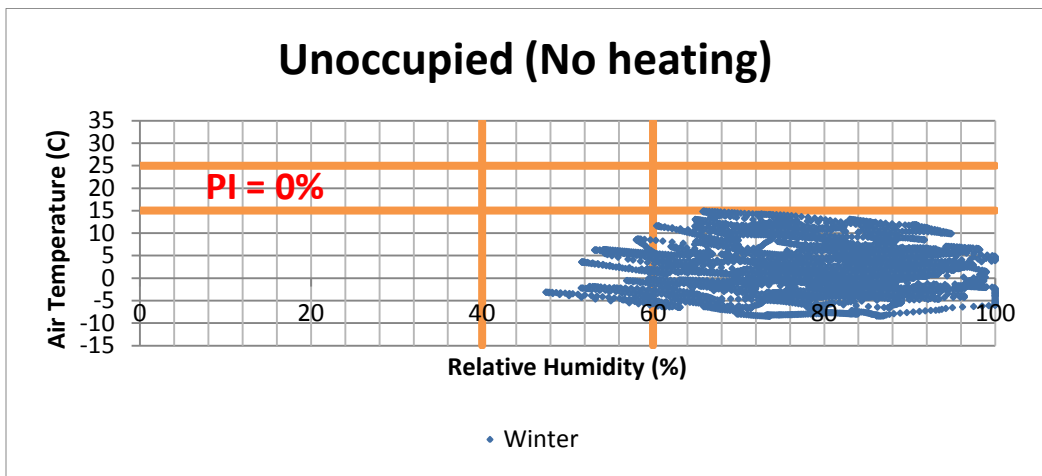

Figure 26 PI unoccupied no heating (winter)

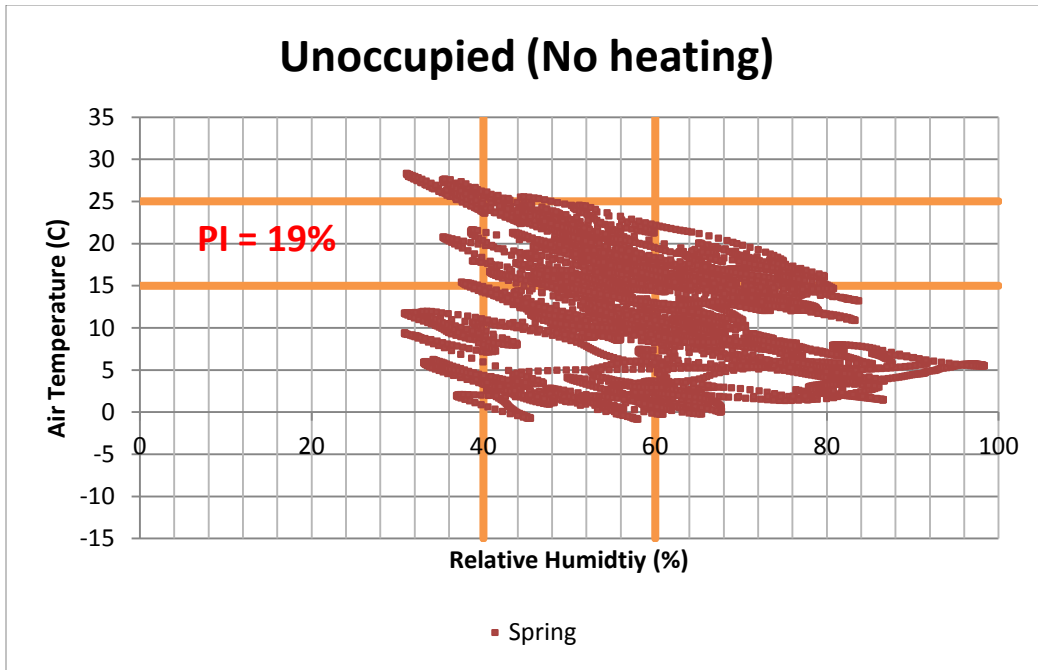

Figure 27 PI unoccupied no heating (spring)

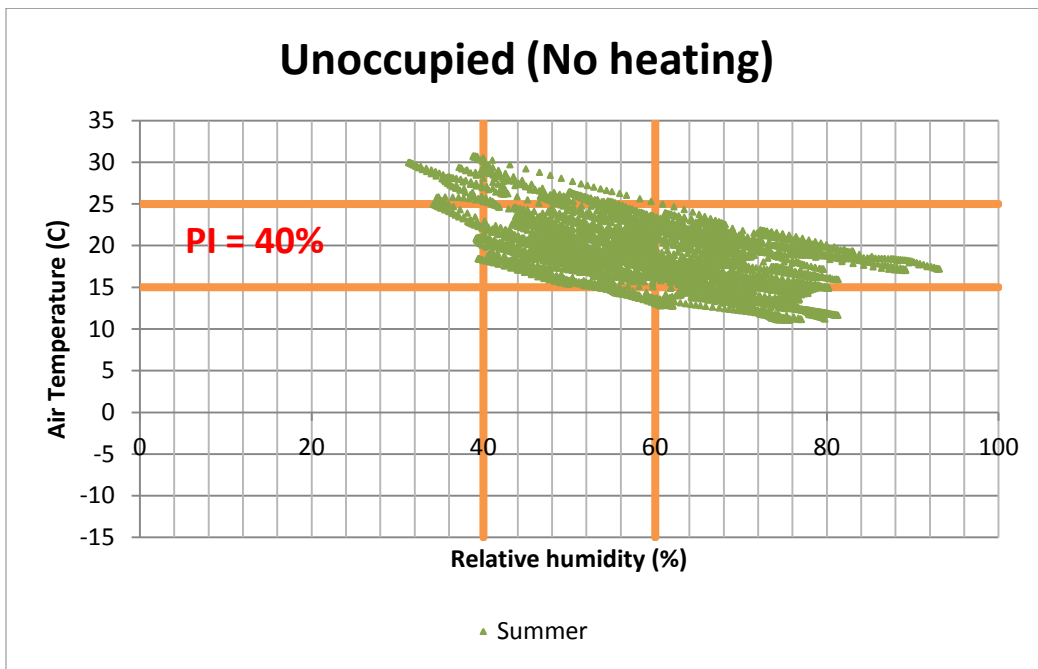

Figure 28 PI unoccupied no heating (summer)

The PI index for all months combined for unoccupied with no heating is 19.6%. The PI is worse during the winter and spring months; an expected result since there's no condensation occurring in the late spring, and summer months. As shown in the previous figures, most of the data points lie in the high humidity zone (bottom-right corner).

Figure 29, Figure 30, and Figure 31 illustrates the PI index for the unoccupied (10C) scenario.

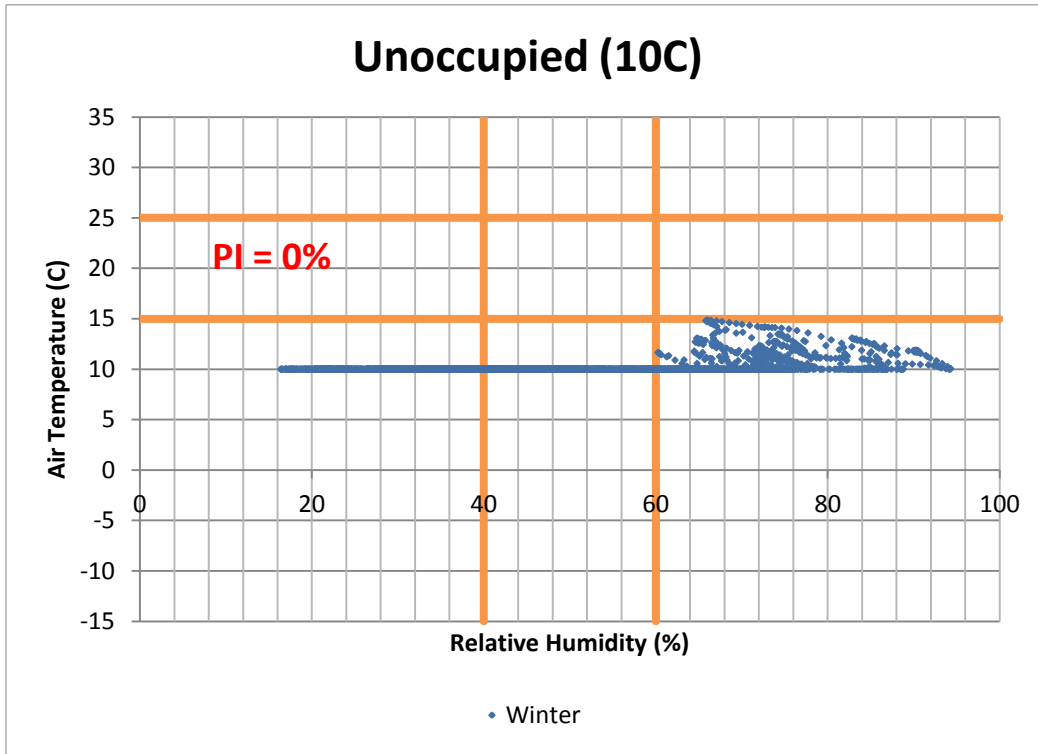

Figure 29 PI unoccupied 10C (winter)

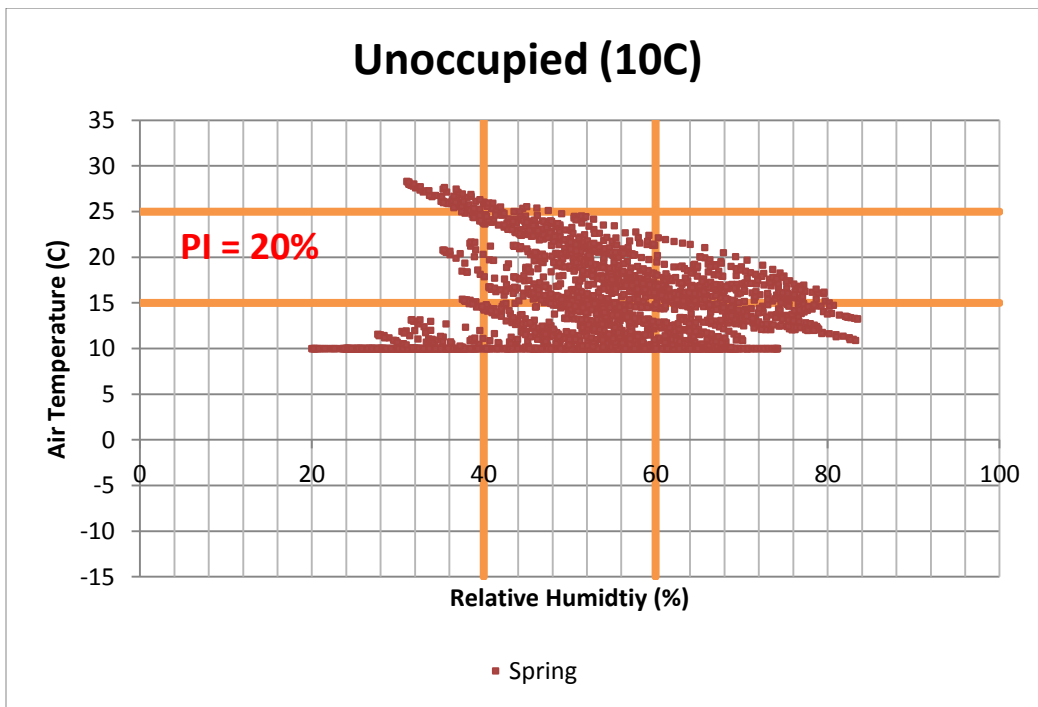

Figure 30 PI unoccupied 10C (spring)

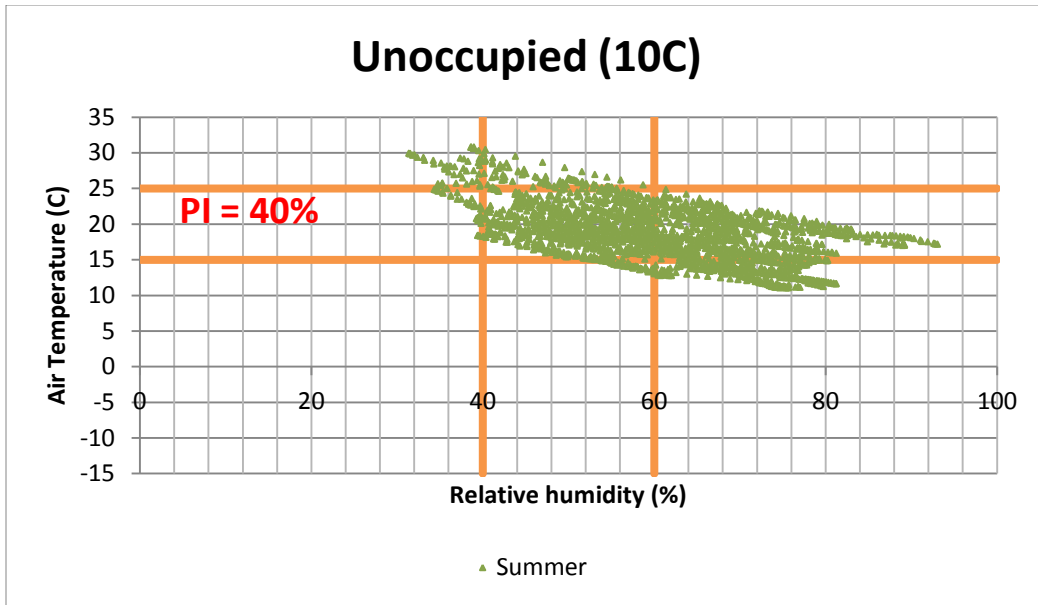

Figure 31 PI unoccupied 10C (summer)

Maintaining a minimum temperature of 10°C improved the PI index slightly. The new PI scored 20%. Although, this PI is not a significant improvement, the data points are no longer dominating the high-relative humidity, low-temperature zone (bottom-right corner). The points are now closer to the optimum PI zone.

5.2.2 Occupied

Figure 32, Figure 33, and Figure 34 illustrates the PI index for the occupied (no heating).

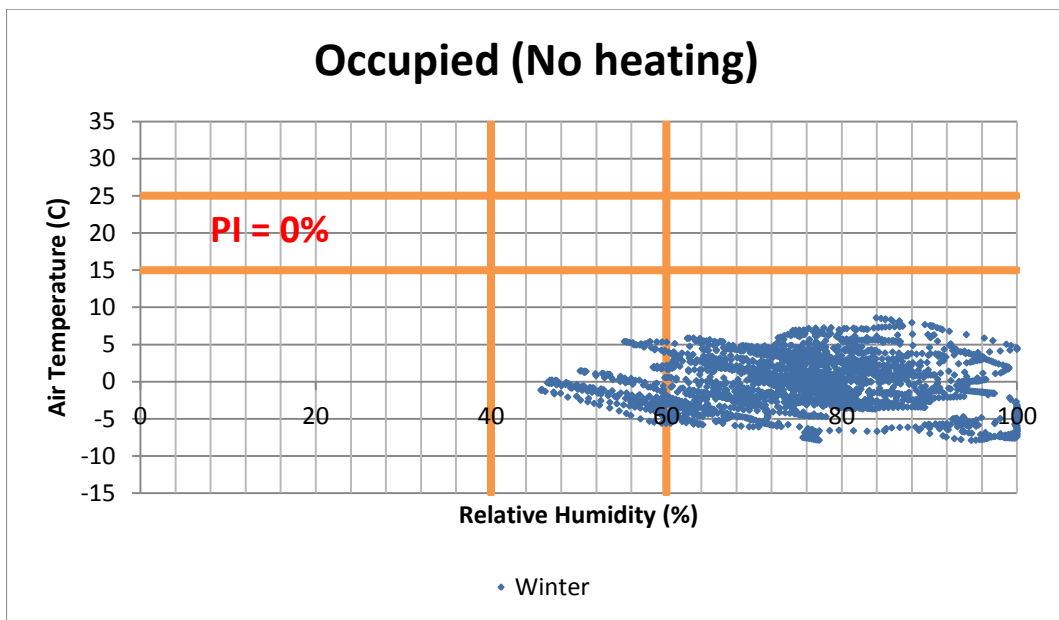

Figure 32 PI occupied no heating (winter)

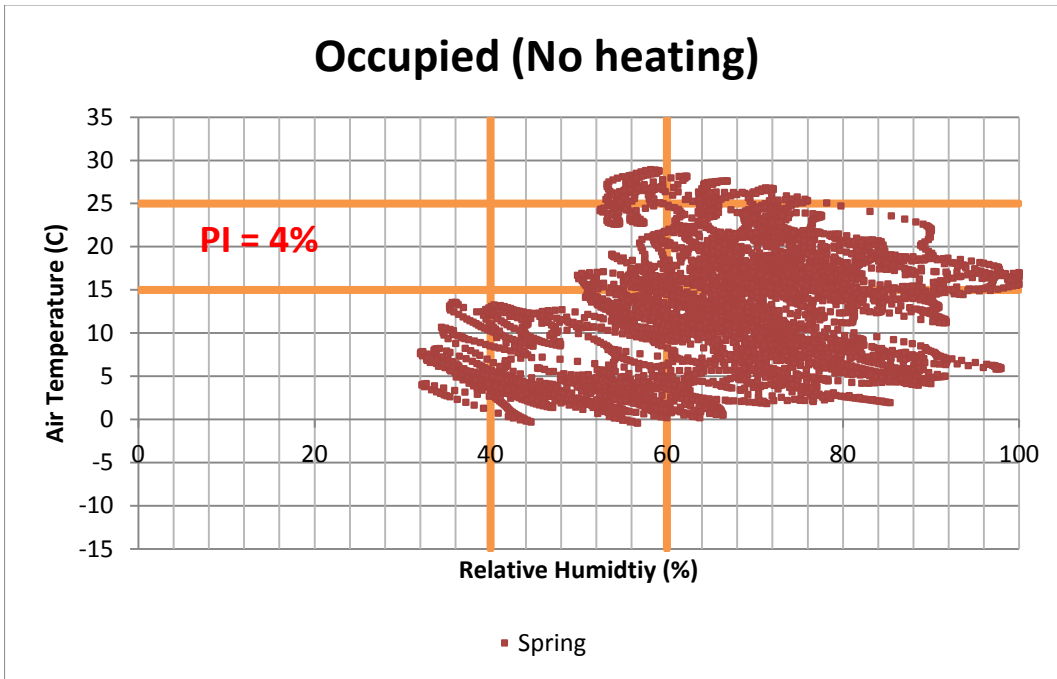

Figure 33 PI occupied no heating (spring)

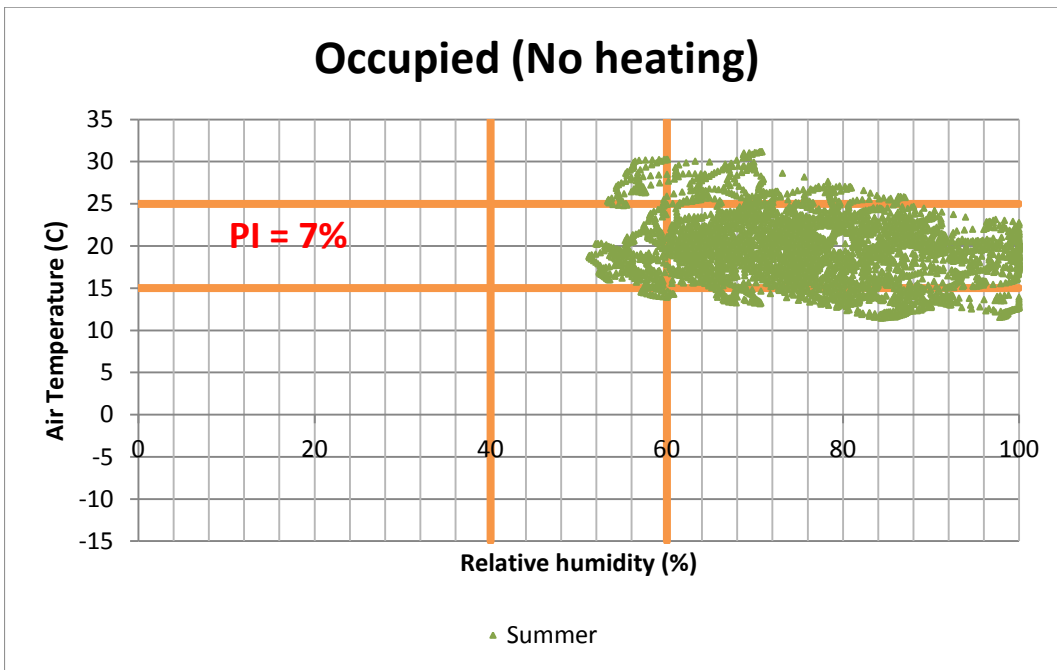

Figure 34 PI occupied no heating (summer)

Unlike the unoccupied zone, the occupied zone's PI scored very poorly at 3% for the no heating case. This is also expected since condensation is occurring in all seasons as previously shown in the results' section. For the winter and spring, data points are, again, dominating the bottom-right corner.

Figure 35, Figure 36, and Figure 37 illustrate the PI index for the occupied (15C).

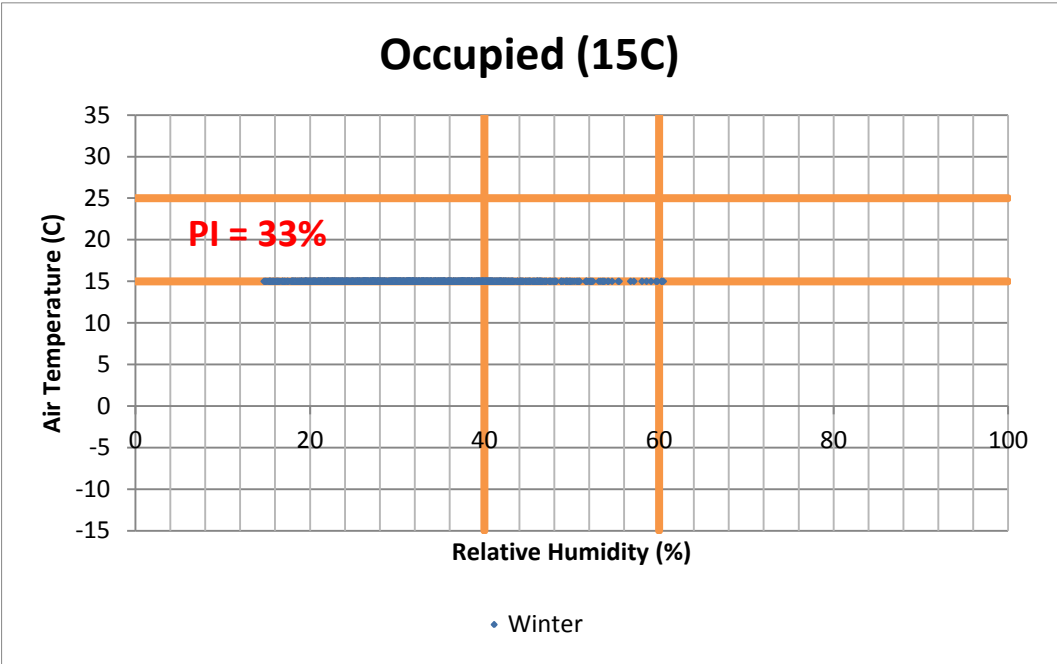

Figure 35 PI occupied 15C (winter)

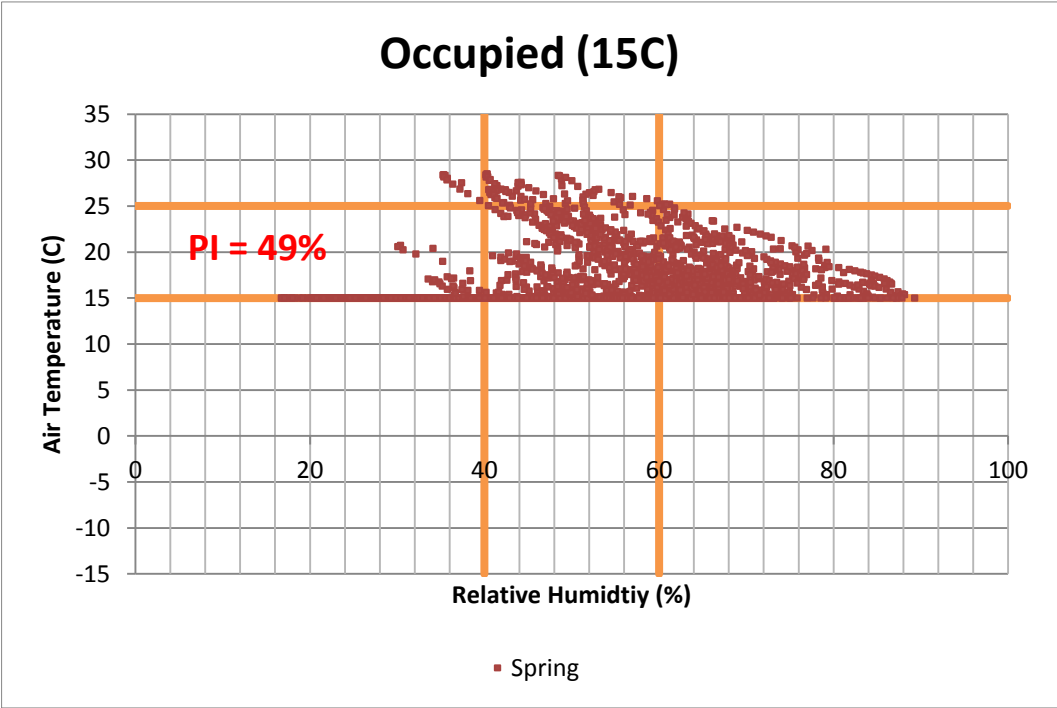

Figure 36 PI occupied 15C (spring)

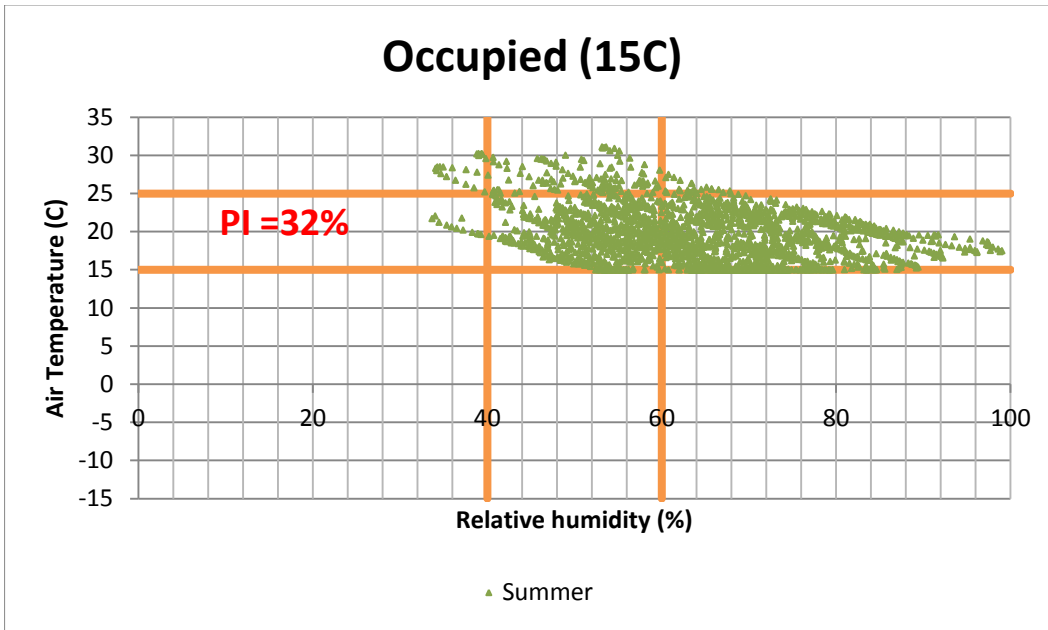

Figure 37 PI occupied 15C (summer)

Maintaining a minimum temperature of 15°C improved the PI index significantly. The new PI scored 38%, with the rest of data points within close proximity to the optimum PI zone.

5.3 Relative Humidity

Figure 38 illustrates the relative humidity values for the unoccupied & occupied functions (no heating).

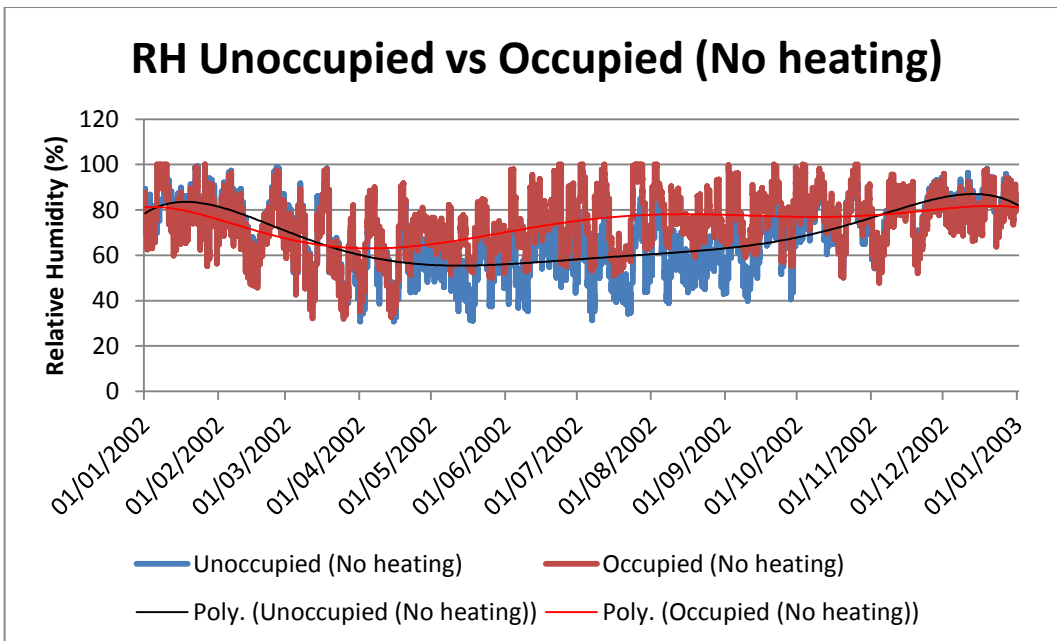

Figure 38 RH unoccupied vs. occupied (no heating)

Figure 39 illustrates the relative humidity values for the unoccupied & occupied functions (no condensation).

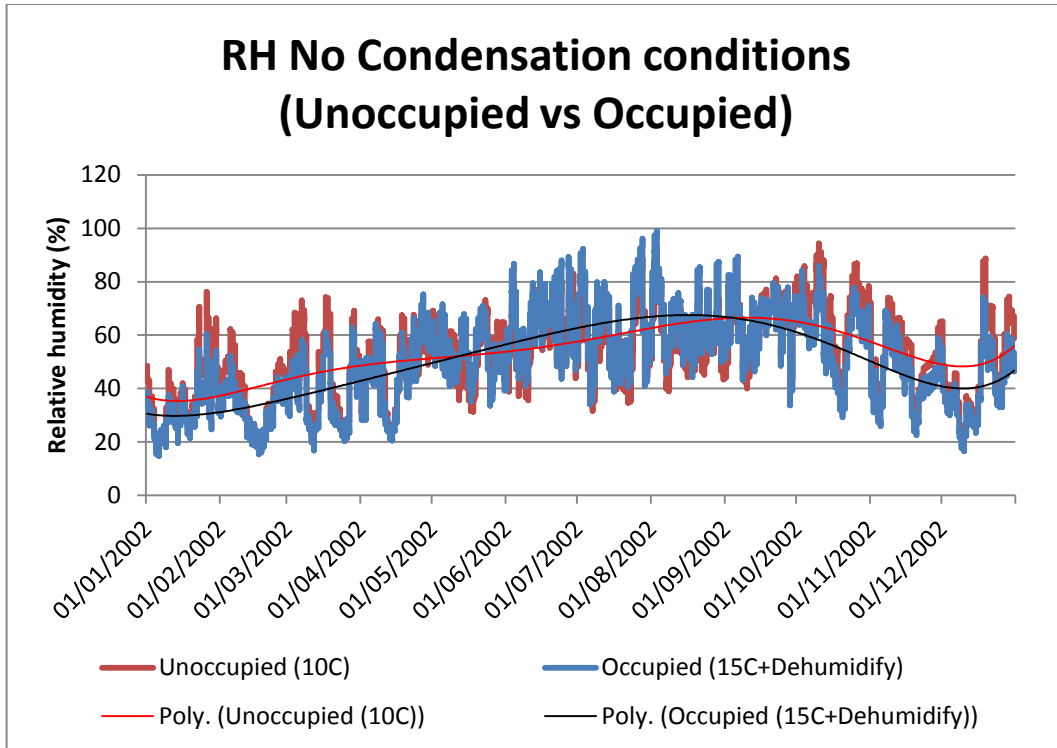

Figure 39 RH unoccupied vs. occupied (no condensation)

As shown in the previous two figures, maintaining a 10°C for the unoccupied, and 15°C+Dehumidify for the occupied improved the relative humidity values significantly. In the no heating conditions, the average RH values ranged between 60%-100%. For the ideal condition, however, that range dropped in value to 35%-65%. Moreover, the number of instances of RH exceeding 60% dropped from 68% and 86% (no heating) for unoccupied and occupied to 35% and 30% (ideal conditions) respectively.

In the case of occupied function, there was a significant drop in the relative humidity values when dehumidification capabilities were utilized. The maximum difference of relative humidity recorded between the 15°C, and 15°C+Dehumidify was 28.3%. As shown in Figure 40, the polynomial trend lines of both scenarios are plotted signifying the drastic drop during the summer months (the months where dehumidification is most needed). This illustrates the importance of using a dehumidification system, especially for the summer months.

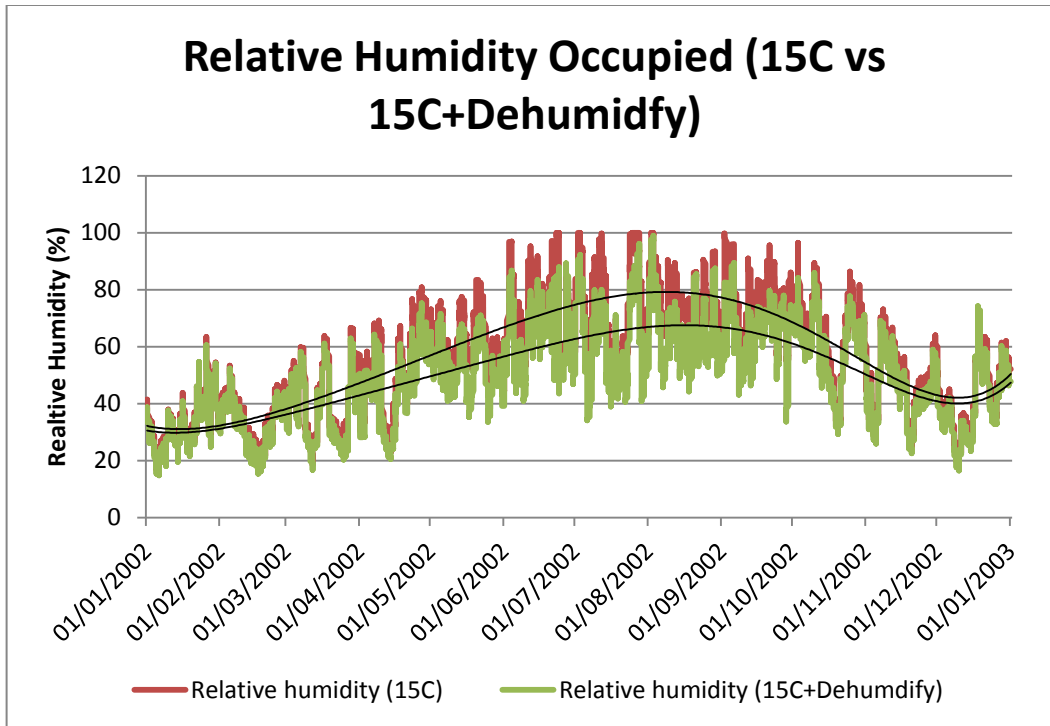

Figure 40 Relative humidity Occupied (15Cvs15C+Dehumidfy)

As mentioned previously, the fluctuations of relative humidity are attributed to the fact that dehumidification runs as per the occupancy schedule.

5.4 Energy Demand

Figure 41, and Figure 42 illustrate the energy demand for the unoccupied, and occupied respectively.

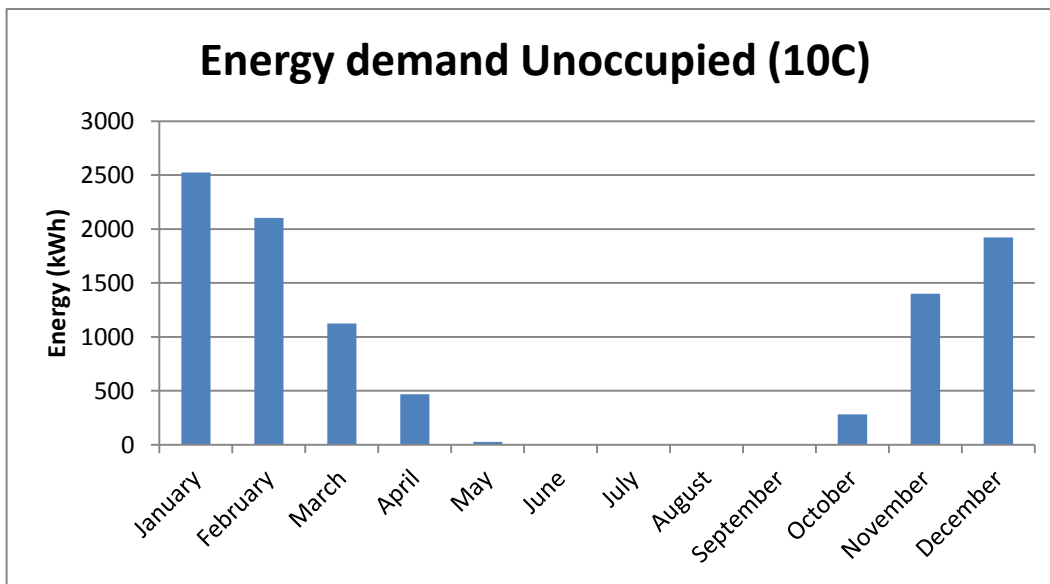

Figure 41 energy demand unoccupied (10C)

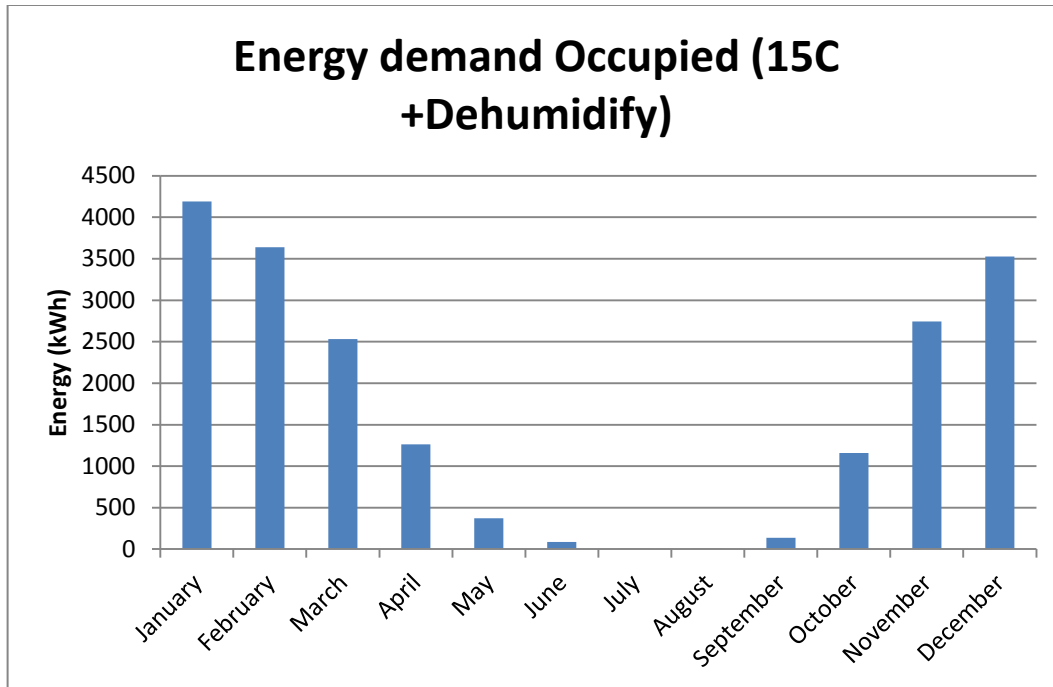

Figure 42 Energy demand occupied (15C+Dehumidify)

For both functions, unoccupied & occupied, the energy demand peaks during the winter months, which is expected as weather is coldest. There is no energy demand in summer for the unoccupied function, and the demand for occupied function is at its minimum. The only energy required during the summer months is for dehumidification.

The energy required can be provided using electricity or gas sources. In general, gas heating is much more economical than electricity. The price of one kWh supplied through electric means is equivalent to €0.129, while the price of one kWh supplied through gas means is equivalent to €0.058 [15]. Table 6 illustrates the total cost for heating the pavilion per year. It must be noted that dehumidification can only be used with an electric HVAC.

Table 6 Cost of fuel consumption

| | Cost per year | |
|--|---------------|------|
| | Electricity | Gas |
| Unoccupied 10C | €1270 | €570 |
| Occupied 15C+Dehumidify (Summer only) | €2184 | N/A |
| Occupied 15C+Dehumidify | €2534 | N/A |

Using electricity alone is a costly way to eliminate condensation. Figure 43 shows the breakdown of the energy demand for the occupied (15°C+Dehumidify). This graph illustrates the difference in energy consumption between heating and dehumidification.

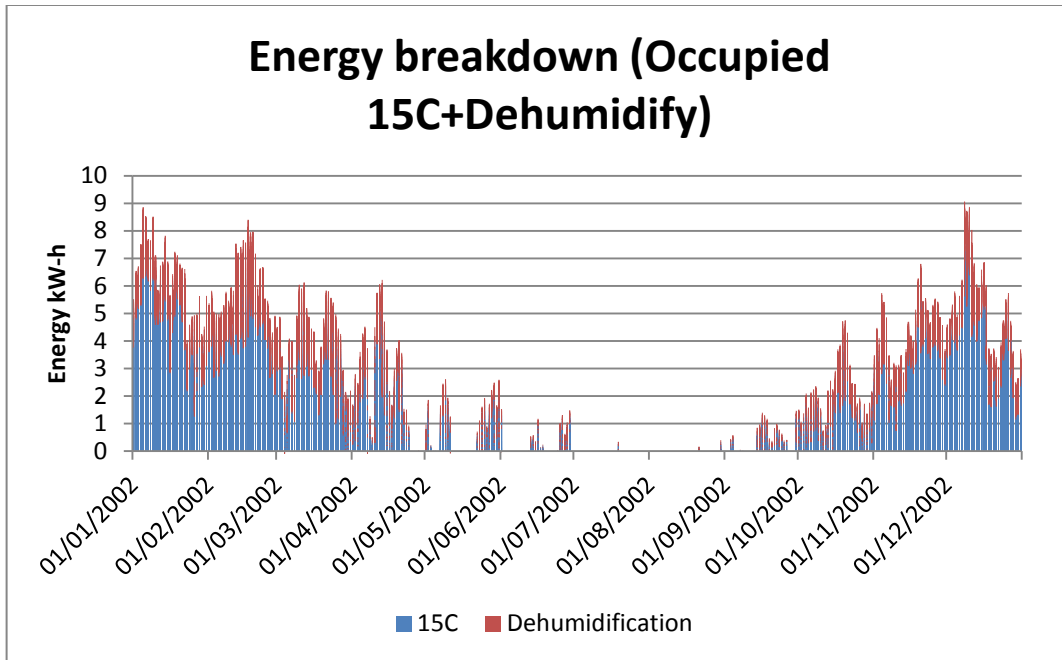

Figure 43 Energy breakdown Occupied (15C+Dehumidify)

Since dehumidification can only be used with electric sources, the cheapest option would be to utilize a hybrid system that uses gas for heating, and electricity for dehumidification. The cost of such system is shown in graph Figure 44.

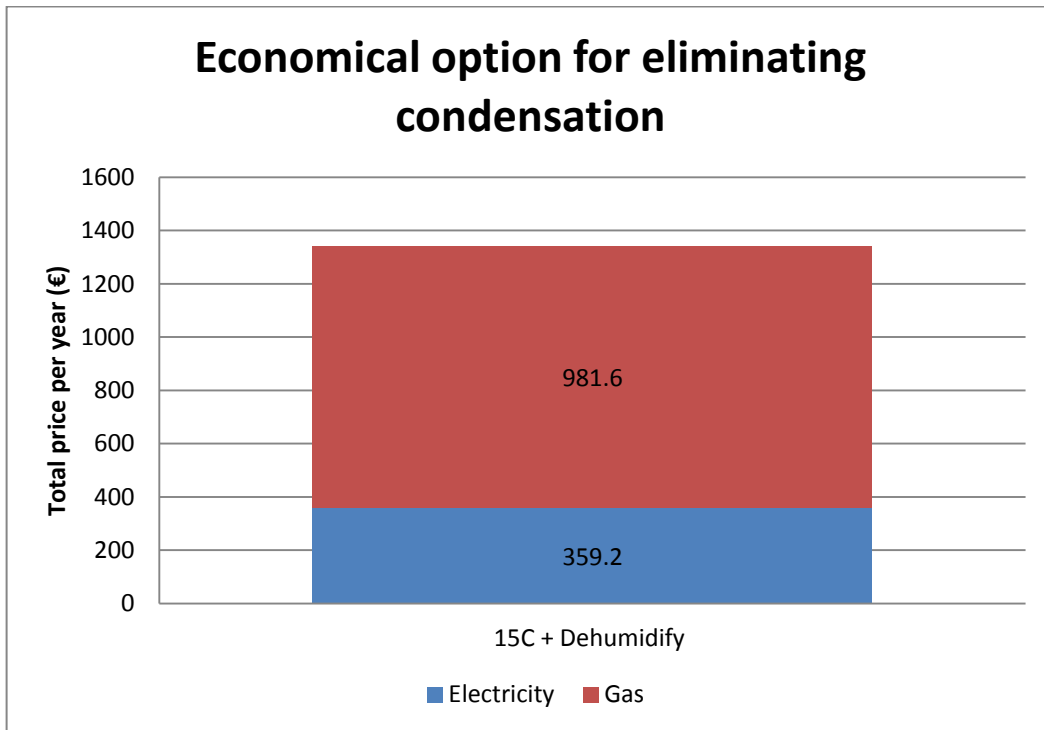

Figure 44 Economical option for eliminating condensation Occupied (15C+Dehumidify)

6. Conclusion

The numerical model created gave a closer look at the extent of the condensation issue in Duchcov. As expected, the condensation rate is detrimental, and serious steps must be taken to limit the condensation. The results obtained confirmed the suspicions over the state of the fresco. That being said, real data should be collected from site to know the exact climatic condition around the pavilion, and inside as well. Said data would allow for the model to be validated, thus yielding accurate measurements of the proposed solutions to mitigate condensation.

The model simulated two different occupancy functions (unoccupied & occupied). The former being the current condition of the pavilion, and the latter being the proposed condition once the pavilion is opened to visitors. It was evident from the results obtained that maintaining a minimum temperature works effectively during the winter & spring months for eliminating condensation for the unoccupied function. However, in order to completely eliminate the condensation during the summer months for the occupied function, a dehumidification measure should be implemented.

For the unoccupied function, a temperature of 10°C must be maintained for the months of January, February, March, November, and December. For the occupied function, however, a 15°C must be maintained throughout the full year, in addition to dehumidification with a set-point of 60%. It was determined that running the dehumidification as per the occupancy scheduled (i.e when people are present in the pavilion) is sufficient to eliminate the condensation completely. Therefore, it is not necessary to run dehumidification 24/7.

The performance index is another topic of extreme importance that was discussed in the report. For the long term, it is necessary to maintain a class A control for the fresco (i.e air temperature between 15°C - 25°C, and 40% RH - 60% RH). It was determined that in heating alone is not sufficient to improve the PI, and that dehumidification is needed. For the unoccupied function, the PI went from 19.6% to 20% (no heating to 10°C). While for the occupied, the PI went from 3% to 38% (no heating to 15°C+Dehumidify). This is a clear evidence of the importance of using dehumidification.

In terms of energy demand, it was determined that eliminating condensation for the unoccupied occupancy would cost €1270/year for electric heating, and €570/year for gas heating. On the other hand, the occupied occupancy would cost €2184/year for electric heating (dehumidification only during the summer months); and €2534/year for electric heating (dehumidification for the full year). However, the most economical way is to utilize a hybrid system that uses gas for heating, and electricity of dehumidification. The cost of such system would come out to be €1340.91 (€359.2 for electricity, and €981.7 for gas). This estimate does not include any capital cost associated with installing either system.

The goal of this project was to create a model to assess the rate of condensation occurring. The next step would be to look at structural interventions to further control the indoor climate. For example, the pavilion is built with reinforced concrete without any insulation. This results in a rapid heat gain/loss. Once these factors are taken into account, it would be viable to consider improving the PI index to fully achieve class A as per ASHRAE specifications.

7. References

- [1] ASHRAE, 2015 Ashrae Handbook: HVAC Applications, Atlanta, 2015.
- [2] P. R. Gardinali, "Chemistry and Fresco Painting," Florida International University, 2015.
- [3] M. Hochel, "Zámek Duchcov hostil symposium k 33. výročí zpřístupnění pavilonu pro Reinerovu fresku," December 2016. [Online]. Available: <https://www.novinky.cz/vase-zpravy/ustecky-kraj/teplice/3172-41480-zamek-duchcov-hostil-symposium-k-33-vyroci-zpristupneni-pavilonu-pro-reinerovu-fresku.html>.
- [4] ceskatelevize, "Reinerova freska si na sebe musí vydělat," ceskatelevize.cz, May 2011. [Online]. Available: <http://www.ceskatelevize.cz/ct24/kultura/1266491-reinerova-freska-si-na-sebe-musi-vydelat>.
- [5] <http://past1978.deviantart.com>, "Reiner Pavilion," 2012. [Online]. Available: <http://past1978.deviantart.com/art/Reiner-Pavilion-158112673>.
- [6] G. Hauptvogelová, "Odborníci se snaží zachránit Reinerovu fresku v Duchcově," January 2017. [Online]. Available: <http://www.zitteplice.cz/odbornici-se-snazi-zachranit-reinerovu-fresku-v-duchcove/>.
- [7] D. Erhardt, F. Antretter and R. Kilian, "Measured and Modeled Influence of the Moisture Buffer Effect in a Historic Stone Church and its Influence on Possible HVAC Measures".
- [8] National Geographic, "Condensation," [Online]. Available: <https://www.nationalgeographic.org/encyclopedia/condensation/>.
- [9] weatherquestions, "What is the dewpoint temperature?," <http://www.weatherquestions.com>, [Online]. Available: http://www.weatherquestions.com/What_is_dewpoint_temperature.htm.
- [10] AutoDesk, "Psychrometric Charts," AutoDesk, [Online]. Available: <https://sustainabilityworkshop.autodesk.com/buildings/psychrometric-charts>.
- [11] ajdesigner, "Dew Point Equations Formulas Calculator," <http://www.ajdesigner.com>, 2015. [Online]. Available: http://www.ajdesigner.com/phphumidity/dewpoint_equation_dewpoint_temperature.php#ajscroll.
- [12] Designbuilder, "Designbuilder Software Product Overview," Designbuilder, [Online].

Available: <https://www.designbuilder.co.uk/software/product-overview> .

- [13] C. Bonacina, F. Cappaelletti, F. Peron, P. Romagnoni and A. G. Stevan, "On the applicability of HVAC systems for cultural heritage: the Wedding Chamber (Camera Picta) in Mantova (Italy)".
- [14] M. Balounova, K. Kabele and S. P. Corgnati, "Condensation risk assessment and IEQ in Pilgrimage chapel of Holy stairs".
- [15] <http://ec.europa.eu>, "File:Electricity and gas prices," 2015. [Online]. Available: [http://ec.europa.eu/eurostat/statistics-explained/index.php/File:Electricity_and_gas_prices,_second_half_of_year,_2013%E2%80%9316_\(EUR_per_kWh\)_YB16.png](http://ec.europa.eu/eurostat/statistics-explained/index.php/File:Electricity_and_gas_prices,_second_half_of_year,_2013%E2%80%9316_(EUR_per_kWh)_YB16.png).