

RD9XMF / ITL9-1

Air-cooled power triode

Output power: 25 kW



TESLA
Electron**Tubes**



RD9XMF is air-cooled triode, made by metal-ceramic technology. This electron tube is intended for industrial generators up to 120 MHz. Application – RF heating, welding, hardening or gluing.

Maximum plate dissipation can be 8.5 kW. Output power is 25 kW in CW mode.

For operation in pulse mode, the parameters depends on equipment characteristics. Contact us for specific information.

RD9XMF / ITL9-1

Air-cooled power triode

Output power: 25 kW



Technical specifications

Cathode	WTh	
Filament voltage	5.8	V
Filament current	145	A
Amplification factor	22	
Transconductance	50	mA/V
Capacitance		
• grid-anode	21	pF
• grid-cathode	55	pF
• cathode-anode	1	pF

Maximum ratings

Frequency	120	MHz
Anode voltage		
• < 30 MHz	12	kV
• ≥ 30 MHz	9-7	kV
Grid voltage	-1500	V
Grid current	1.5	A
Grid dissipation	350	W
Anode dissipation	8.5	kW
Peak cathode current	25	A

Mechanical characteristics and cooling

Anode cooling	air	
Air inlet temperature	45	°C
Temperature (any point of envelope)	200	°C
Air outlet temperature	75	°C
Air flow	9.5	m ³ /min
Mounting position	vertical	
Weight	4.4	kg

Additional accessories*

- Grid contact ring

*for detailed information please contact our sales department

Outline drawing

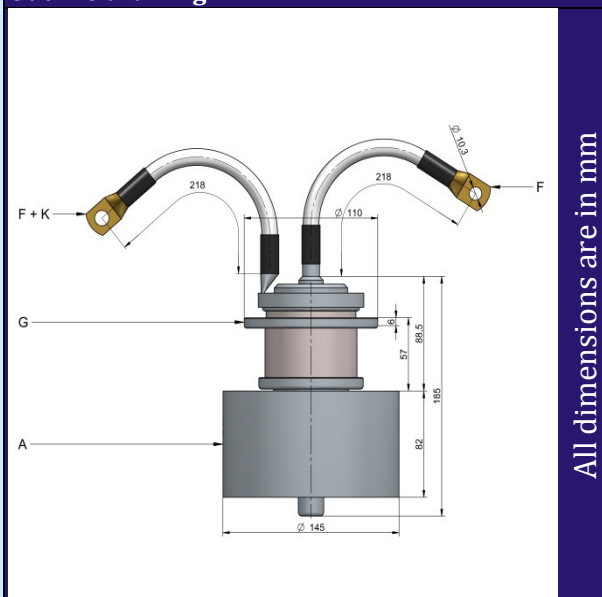

Constant current characteristics

