

**Czech Technical University in Prague**

Faculty of Mechanical Engineering

Department of Automotive, Combustion Engine and Railway Engineering

in cooperation with

**Ricardo Prague s.r.o.**



Diploma Thesis

**Hybrid Vehicle Driveline Concept**

Bc. Pavel Fabry

## **Declaration**

I hereby declare that I have elaborated this diploma thesis on the  
*„Hybrid Vehicle Driveline Concept“*  
on my own, with the use of literature and information  
which is referenced in the thesis.

In Prague on the 13<sup>th</sup> January 2017

Signature

## **Annotation**

**Title:** Hybrid Vehicle Driveline Concept

**Author:** Bc. Pavel Fabry

**Supervisor:** Doc. Dr. Ing. Gabriela Achtenová (CTU Prague)  
Ing. Filip Hostaš (Ricardo Prague s.r.o.)

**Academic year:** 2016/2017

**Department:** Ú 12120 – Department of Automotive, Combustion Engine and Railway Engineering

**Extent:** 70 pages  
30 images  
3 tables (+ 1 annexed)  
6 annexes

**Annotation:** This diploma thesis is focused on proposing a concept of a double clutch transmission for a B-segment car powered by a petrol engine and two electric motor-generators. The concept is supported with a duty cycle load simulation. Its basic driveline parameters are evaluated using a simulation of the NEDC (New European Driving Cycle).

**Keywords:** Concept, double clutch transmission, B-segment car, hybrid, NEDC

## **Acknowledgement**

I would like to thank Doc. Dr. Ing. Gabriela Achtenová for supervising and supporting my work on this thesis and its successful completion.

I would like to thank Ing. Filip Hostaš for outlining and leading my progress and giving directions and support during elaboration of the thesis. Special thanks also belong to Ing. Marek Sytný, Ing. Jaromír Bilík and Ing. Jakub Toman for their advice during software work and data assessment.

Last but not least, I would like to thank my girlfriend Gabriela Duchanová and all the family for their endless support and patience over the course of working on this thesis.

## Contents

1	Introduction .....	8
1.1	Thesis Overview .....	8
1.2	Tasks .....	9
1.3	About Ricardo.....	9
2	Benchmark .....	10
2.1	Market Research .....	10
2.2	Reference Vehicle.....	10
2.2.1	Vehicle Body.....	10
2.2.2	Tyres.....	11
2.2.3	Engine and Performance Figures .....	11
2.2.4	Electric Motors .....	13
3	Gearbox Proposal .....	14
3.1	Gearbox Spread .....	14
3.1.1	Highest Gear Ratio .....	15
3.1.2	Lowest Gear Ratio.....	21
3.1.3	Gearbox Spread and Gear Steps Calculation .....	23
3.2	Gearbox Layout .....	28
3.2.1	Proposed Design.....	28
3.2.2	Proposed Shifting Strategy.....	29
3.2.3	Parameters of Gear Pairs .....	33
3.2.4	Dimensions of Gear Pairs.....	34
3.2.5	Actual Gear Ratios .....	40
3.3	3D CAD Concept.....	41
3.3.1	3D CAD Concept .....	41
4	Load Cycle Simulation.....	44
4.1	Duty Cycle.....	44
4.2	SABR Simulation .....	45
4.2.1	Bearing Life.....	45
4.2.2	Shaft Deflections .....	46
5	NEDC Simulation .....	49
5.1	NEDC Characteristics.....	49

5.1.1	Urban Driving Cycle .....	49
5.1.2	Extra-Urban Driving Cycle .....	50
5.1.3	Combined NEDC .....	51
5.2	QSS Toolbox .....	51
5.3	Vehicle Models.....	52
5.3.1	Ford Fiesta.....	52
5.3.2	Non-Hybrid Reference Vehicle.....	56
5.3.3	Hybrid Reference Vehicle.....	59
6	Conclusion.....	66
7	List of Figures .....	67
8	List of Tables.....	68
9	List of Annexes .....	68
10	Used Literature.....	69

## Overview of Used Variables

$a [m \cdot s^{-2}]$	acceleration
$a [mm]$	axial distance
$c_x$	drag coefficient
$d [mm]$	pitch diameter
$F [N]$	force
$f$	coefficient of rolling resistance
$g [m \cdot s^{-2}]$	acceleration of gravity
$h [mm]$	height of the centre of gravity
$i$	gear ratio
$l [mm]$	wheelbase
$m [kg]$	weight
$m_n [mm]$	normal module
$m_t [mm]$	transverse module
$n [min^{-1}]$	rotational speed
$P [kW]$	power
$q$	base ratio change
$q_2$	progression factor
$r_d [mm]$	wheel dynamics radius
$S_x [m^2]$	vehicle frontal area
$T [Nm]$	torque
$v [m \cdot s^{-1}]$	speed
$z$	number of speeds
$z$	number of teeth
$\beta$	helix angle
$\delta$	coefficient of rotational inertia
$\eta$	efficiency
$\mu_{ad}$	coefficient of adhesion
$\rho [kg \cdot m^{-3}]$	density
$\omega [rad \cdot s^{-1}]$	rotational speed

# 1 Introduction

---

## 1.1 Thesis Overview

This diploma thesis focuses on proposing and developing a concept of a driveline of a hybrid vehicle based on a B-segment car. The reasons for choosing this topic were my internship in Ricardo Prague s.r.o. and interest in the fields of automotive transmissions and hybrid vehicles.

These days, we know lots of different concepts of hybrid vehicles. The variety of solutions comes with the variety of demands, questioning whether the effort is made to lower the fuel consumption, reduce the impact on the environment or boost the vehicle's performance. It also comes with the regard to the use of the vehicle, whether it is designed to be a city car, motorway mile-muncher or anything else.

The idea behind this thesis is to try and evaluate the concept of mounting two relatively small electric motors to a double-clutch transmission of a B-segment car which has its natural habitat in city streets but is also used for longer travels outside the town.

The general layout of the concept was given. The internal combustion engine is connected via a double-clutch package to the input shafts of the gearbox. Each input shaft also has one electric motor mounted to it. Torque is transmitted through conventional gear pairs to the output shafts of the gearbox and through final drives to the differential.

The task was to propose a specific concept with selected number of gears and their relative positions and the means of mounting the electric motors to the gearbox. The concept was developed using Catia V5 3D CAD modelling software.

The design was then transformed into computational model for the Ricardo supplied SABR software to calculate and check the bearings' life and deflections of specific shafts.

The last step was to create a mathematical model of the vehicle driveline to estimate basic driveline parameters for comparison with a conventional vehicle only using an internal combustion engine.



## 1.2 Tasks

1. Propose a concept of a double-clutch transmission for a B-segment car powered by a petrol engine and two electric motor-generators based on a study lay out as shown in the scheme below.
2. Support the design with a duty cycle load simulation.
3. Simulate the NEDC (New European Driving Cycle) to evaluate the basic driveline parameters.

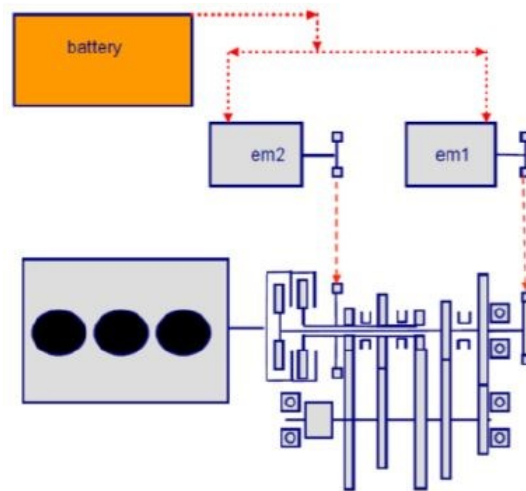

**Figure 1: Study layout**

*Source: Ricardo*

## 1.3 About Ricardo

Ricardo plc is a global engineering, strategic and environmental consultancy. It was founded on 8<sup>th</sup> February 1915 and is named after its establisher – Sir Harry Ricardo. The company is based in Shoreham-by-Sea in the United Kingdom but spreads out globally and currently employs over 2700 engineers, scientists and consultants across the world. The firm specialises in three main areas – Transport&Security, Energy and Scarce Resources&Waste.

Ricardo Prague s.r.o. is Ricardo's subsidiary in the Czech Republic with its headquarters in Prague 8. It was established in 2000 and currently employs around 200 people.

The topic of this diploma thesis originates from Ricardo Prague. The thesis was elaborated in cooperation with its engineers and use of its software and data.

## 2 Benchmark

---

Prior to developing a concept of the hybrid transmission, a reference vehicle is needed. As the gearbox is to be designed for a B-segment car, it is necessary to undertake a research of the current market to see typical dimensions, performance figures and other important values of vehicles in this category.

### 2.1 Market Research

A survey was done to collect data on B-segment models of various car makers. Listed below is information about installed engines, namely their aspiration, displacement, maximum output power and torque. Further, and mainly for reference, data of used gearboxes and tyres were collected. Following are curb weights, top speeds and times of acceleration from 0 to 100 km/h. At the end, there is information about fuel consumption and wheelbase of considered cars.

Collected data are listed in a table. Due to its size, the table is attached as an annex of the thesis.

### 2.2 Reference Vehicle

With data collected, a reference vehicle can be created. However, this vehicle is not a simple mix of average values of each column. Some parameters are calculated as average values but certain other result from different approaches.

#### 2.2.1 Vehicle Body

Concerning the vehicle body, parameters important for further calculations are: curb weight, wheelbase, drag coefficient and frontal area. Curb weight and wheelbase were calculated as average values of all considered cars. As drag coefficient and frontal area data are more problematic to obtain for every vehicle, values were estimated from available figures (approved by supervisor).

The resulting values are:

Curb weight:  $m_{curb} = 1163 \text{ kg}$

Wheelbase:  $l = 2514 \text{ mm}$

Drag coefficient:  $c_x = 0.29$

Frontal area:  $S_x = 2.23 \text{ m}^2$

## 2.2.2 Tyres

Considering the range of tyres used on listed cars, the reference vehicle was given 185/60 R15 tyres.

## 2.2.3 Engine and Performance Figures

As this thesis focuses on creating a concept of a hybrid car, the chosen engine is not one of the engines listed above. The intention was to find an engine with output power around 60 kW so that there is room for electric motors to supply the power remaining to match the average power of the listed engines. That is 80 kW (82 kW if repeating units are only considered once). For this purpose, the Ford 1.25 DuraTec engine was chosen. Its parameters are:

Maximum power:  $P_{ICEmax} = 60 \text{ kW}$  at 5800 rpm

Maximum torque:  $T_{ICEmax} = 114 \text{ Nm}$  at 4200 rpm

The average top speed of production cars in the B-segment is 188 km/h. For the reference vehicle, the proposed top speed for further calculations was set to 190 km/h.

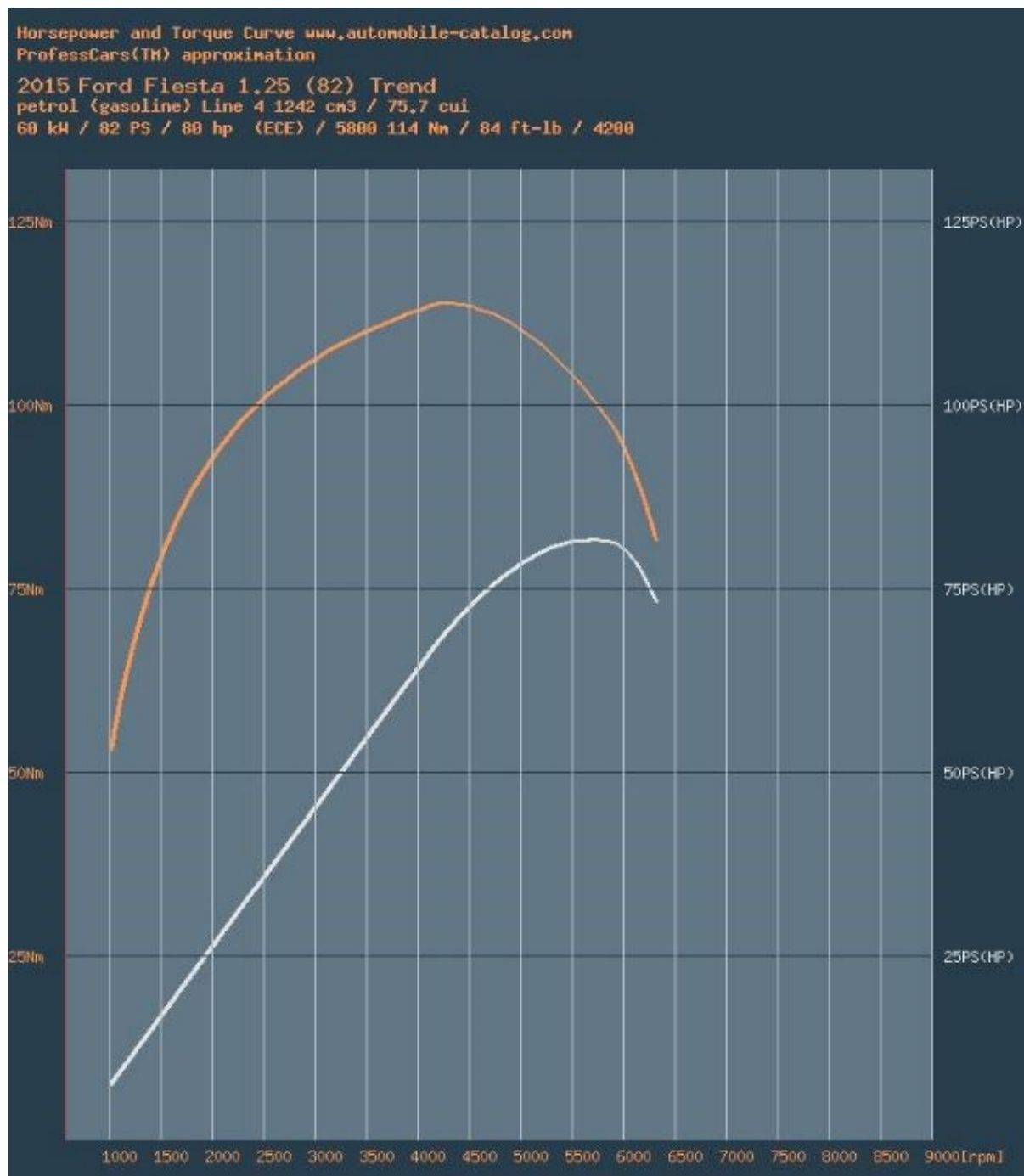

Figure 2: Ford 1.25 DuraTec performance characteristics [3]

## 2.2.4 Electric Motors

The internal combustion engine will be supplemented with two electric motors. While choosing the motor, two categories were considered – induction motors and permanent magnet synchronous motors (PMSM). Induction motors use proven technology and can provide high revolution speeds. However, PMSM motors come with better efficiency and are smaller and lighter. These qualities are needed when trying to replace a typical idea of one electric motor in a hybrid vehicle with two smaller ones and mate them with the gearbox. A PMSM motor was thus chosen.

Specifically, Parker SKW091-092-LAM was selected. Its basic parameters are:

Rated power:	15.4 kW
Rated torque:	12.2 Nm
Rated speed:	12 000 rpm
Maximum torque:	23 Nm

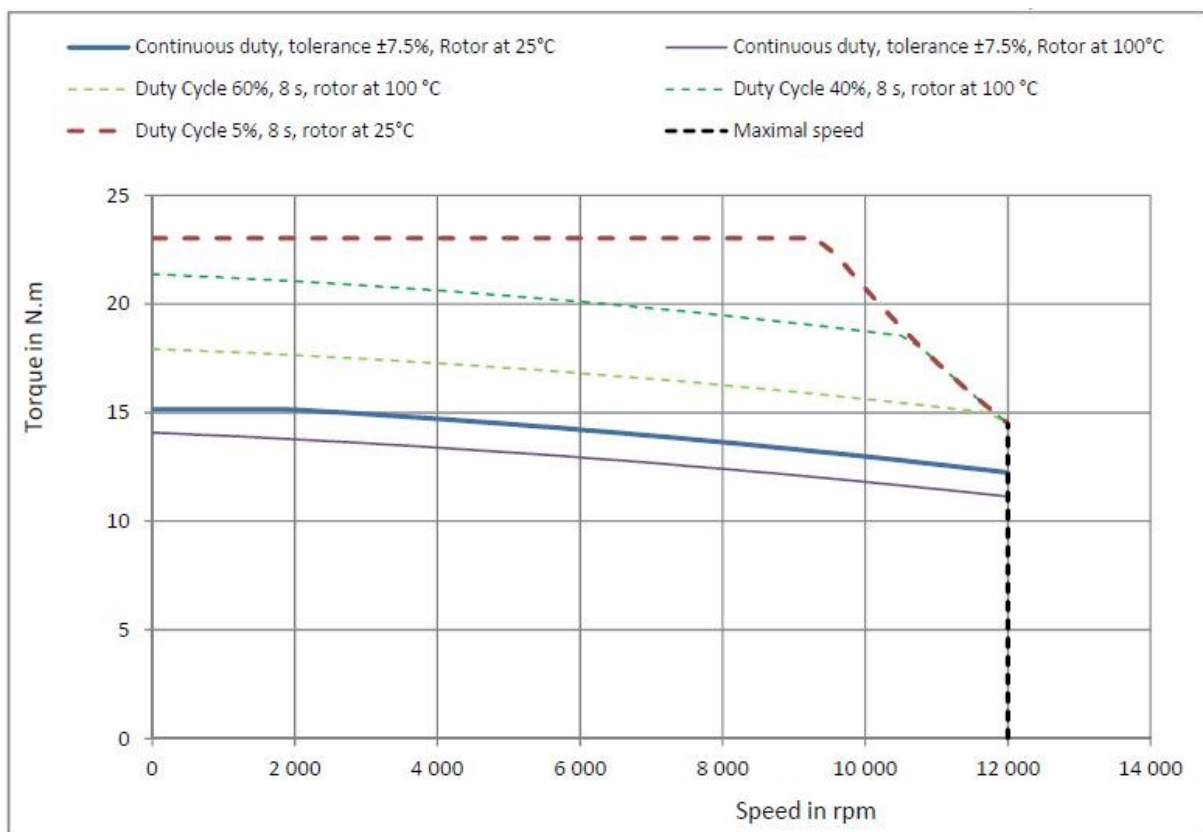

Figure 3: Parker SKW091-092-LAM performance characteristics [4]

## 3 Gearbox Proposal

---

### 3.1 Gearbox Spread

Knowing the characteristics of the reference vehicle, a specific gearbox can be proposed. First, it is necessary to establish the gearbox spread, which is done by calculating the first (highest) and the last (lowest) gear ratio. The prerequisite of obtaining these is to know the tractive force that needs to be provided to ensure motion of the vehicle.

The tractive force mainly consists of the following components:

$$F_{tr} = F_{air} + F_{roll} + F_{grad} + F_{acc} \quad (1)$$

- $F_{air}$  is the force needed to overcome the air resistance

$$F_{air} = \frac{1}{2} \rho_{air} \cdot c_x \cdot S_x \cdot v^2 \quad (2)$$

- $\rho_{air}$  is the ambient air density
  - $c_x$  is the drag coefficient of the vehicle
  - $S_x$  is the frontal area of the vehicle
  - $v$  is the vehicle speed
- $F_{roll}$  is the force needed to overcome the rolling resistance between the tyres and the road surface

$$F_{roll} = m \cdot g \cdot f \cdot \cos \alpha \quad (3)$$

- $m$  is the mass of the vehicle
- $g$  is the acceleration of gravity
- $f$  is the rolling friction coefficient between the tyre and the road surface
- $\alpha$  is the angle of the road slope (for gradients lower than 10%, this component can be neglected, i.e.  $\cos \alpha = 1$ )

- $F_{grad}$  is the force needed to overcome the gradient of the road

$$F_{grad} = m \cdot g \cdot \sin \alpha \quad (4)$$

- $\alpha$  is the angle of the slope

- $F_{acc}$  is the force needed to ensure desired acceleration

$$F_{acc} = m \cdot a \cdot \delta \quad (5)$$

- $a$  is the acceleration of the vehicle
- $\delta$  is the coefficient of rotational inertia for simplification of the calculation of this force

In this case of proposing only a concept of a vehicle, other resistances are not considered.

### 3.1.1 Highest Gear Ratio

The highest gear ratio enables maximum torque multiplication to ensure the vehicle drives off from a standstill. To calculate the tractive force needed for the highest gear ratio, conditions of the drive-off need to be estimated.

#### 3.1.1.1 Vehicle Mass

The curb weight of the reference vehicle was calculated in the previous chapter (see 2.2.1) as 1163 kg. On top of that, a 250 kg battery pack plus extra 400 kg for the car load was considered. The total mass of the reference vehicle is therefore:

$$m = m_{curb} + m_{bat} + m_{load} = 1163 + 250 + 400 = 1813 \text{ kg}$$

#### 3.1.1.2 Air Resistance

As the vehicle is moving off from a standstill, its initial speed is zero. That means the air resistance, the so-called “drag”, can be neglected. Therefore,  $F_{air} = 0$ .

### 3.1.1.3 Rolling Resistance

To estimate the correct coefficient of rolling resistance, the following look-up table was used:

Road surface	Rolling resistance coefficient $f_R$
<i>Firm road surface</i>	
Smooth tarmac road	0.010
Smooth concrete road	0.011
Rough, good concrete surface	0.014
Good stone paving	0.020
Bad, worn road surface	0.035
<i>Unmade road surface</i>	
Very good earth tracks	0.045
Bad earth tracks	0.160
Tracked tractor on acre soil	0.070–0.120
Clamp wheels on acre soil	0.140–0.240
Loose sand	0.150–0.300

**Table 1: Coefficients of rolling resistance [1]**

Assuming the vehicle is predominantly going to be driven on tarmac or concrete roads, the coefficient of rolling friction was estimated at  $f = 0.011$ . The resulting rolling resistance force is therefore:

$$F_{roll} = m \cdot g \cdot f \cdot \cos \alpha = 1813 \cdot 9.81 \cdot 0.011 \cdot \cos 15^\circ = 189.0 \text{ N}$$

### 3.1.1.4 Gradient Resistance

The vehicle in question would also need to be able to drive off on a steep slope. The maximum angle of such slope was estimated at  $15^\circ$ . The background for this figure comes from a search for the steepest road in the world. According to [5], such road is located in Dunedin, New Zealand. Its average slope is 20% ( $\approx 11^\circ$ ) but the angle reaches as high as 35% ( $\approx 19^\circ$ ). A decision was made to set the value for the highest ratio calculation to average  $15^\circ$  as the intention of this thesis is not to break world records but get a figure that could give a good probability to cover the majority of the roads in the world.

The resulting gradient resistance is therefore:

$$F_{grad} = m \cdot g \cdot \sin \alpha = 1813 \cdot 9.81 \cdot \sin 15^\circ = 4603.2 \text{ N}$$



### 3.1.1.5 Acceleration Resistance

For the purpose of calculating the acceleration resistance, a simplified method was used, calculating the resistive force from the maximum acceleration and a coefficient of rotational inertia. Because the acceleration happens with the fully loaded vehicle moving off on the steepest slope, the maximum acceleration was set to  $\alpha = 0.5 \text{ m} \cdot \text{s}^{-2}$ . The coefficient of rotational inertia to  $\delta = 1.3$ .

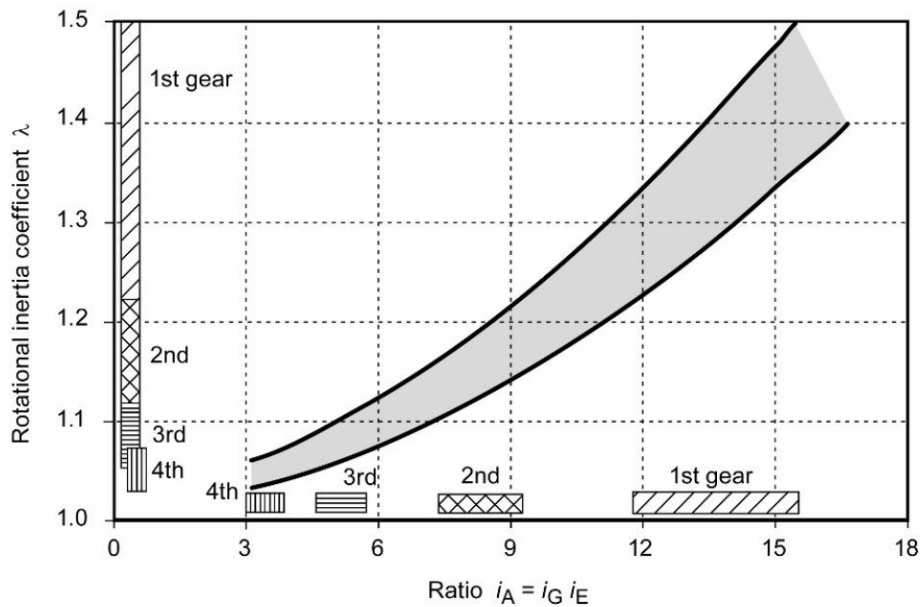

**Figure 4: Dependence of coefficient of rotational inertia on gear ratio [1]**

The resulting acceleration resistance force is therefore:

$$F_{acc} = m \cdot a \cdot \delta = 1813 \cdot 0.5 \cdot 1.3 = 1178.5 \text{ N}$$

### 3.1.1.6 Total Tractive Force

The total tractive force acting on the vehicle wheels is the sum of all tractive force components:

$$F_{tr} = F_{air} + F_{roll} + F_{grad} + F_{acc} = 0 + 189.0 + 4603.2 + 1178.5 = 5970.7 \text{ N}$$

### 3.1.1.7 Transmittable Force on Wheels

Before proceeding to calculate the gear ratio, the tractive force must be checked against the adhesion limit which must not be exceeded. In such case, the vehicle would start spinning its wheels instead of moving off.

$$F_{tr} \leq F_{ad} \quad (6)$$

Considering the case of a vehicle accelerating uphill, the following example is applied:

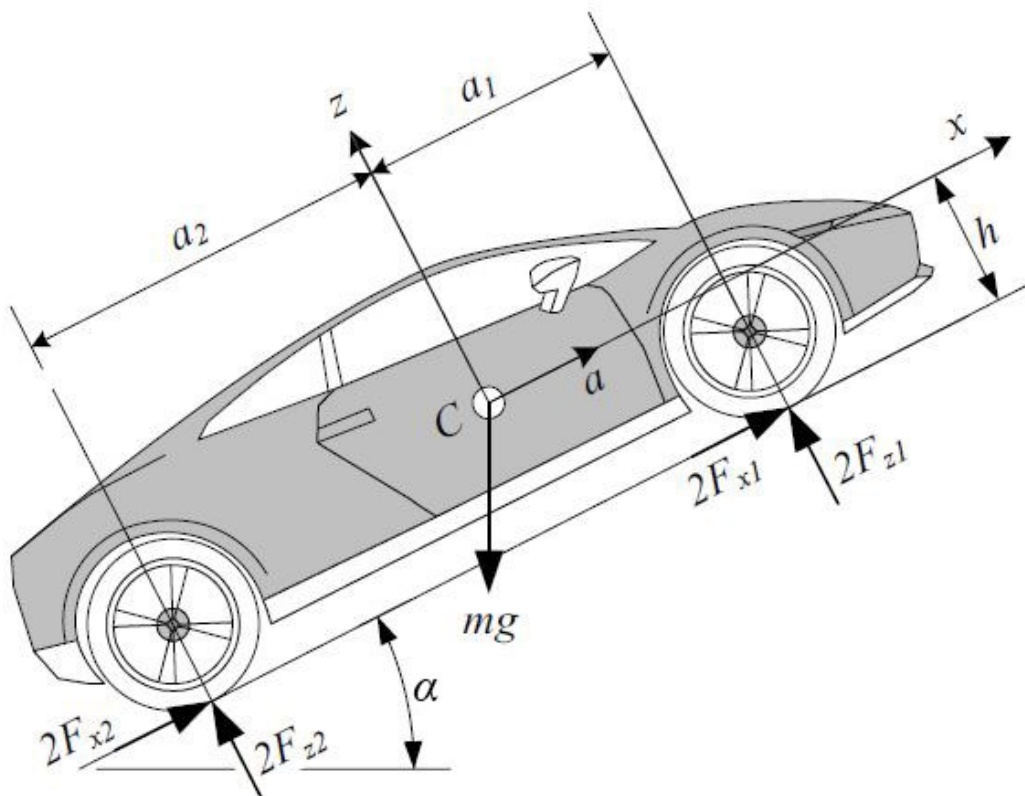

**Figure 5: An accelerating car on inclined road [6]**

The adhesion limit can be calculated from the reaction forces acting on wheels in the direction perpendicular to the road surface, using the following expression:

$$F_{ad} = \mu_{ad} \cdot F_z \quad (7)$$

The reaction force in the z-direction (as indicated in Fig.5) can be calculated for the front wheel as:

$$F_{z1} = \frac{1}{2}mg \left( \frac{a_2}{l} \cos \alpha - \frac{h}{l} \sin \alpha \right) - \frac{1}{2}ma \frac{h}{l} \quad (8)$$

For the rear wheel as:

$$F_{z2} = \frac{1}{2}mg \left( \frac{a_1}{l} \cos \alpha + \frac{h}{l} \sin \alpha \right) + \frac{1}{2}ma \frac{h}{l} \quad (9)$$

- $F_{z1,2}$  are the reaction forces acting on front/rear wheels
- $l$  is the vehicle wheelbase
- $a_{1,2}$  are the distances of the centre of gravity from the front/rear axles
- $h$  is the height of the centre of gravity

Assuming the vehicle in question has front-wheel drive, the front wheels are the ones of interest. Estimating the height of the centre of gravity at 300 mm above the road surface and the weight distribution at 55:45 from the front to the back, the reaction force is:

$$F_{z1} = \frac{1}{2}mg \left( \frac{a_2}{l} \cos \alpha - \frac{h}{l} \sin \alpha \right) - \frac{1}{2}ma \frac{h}{l}$$

$$F_{z1} = \frac{1}{2} \cdot 1813 \cdot 9.81 \cdot \left( \frac{1382.7}{2514} \cos 15^\circ - \frac{0.3}{2514} \sin 15^\circ \right) - \frac{1}{2} \cdot 1813 \cdot 0.5 \cdot \frac{0.3}{2514} = 4395.6N$$

Values of coefficients of adhesion can be found in the following look-up table:

Road speed (km/h)	Static coefficient of friction $\mu_H$	
	Dry road surface	Wet road surface
50	0.85	0.65
90	0.80	0.60
130	0.75	0.55

**Table 2: Coefficients of adhesion [1]**

The coefficient of adhesion for the speeds close to zero was estimated at 0.9. Thus, the adhesion force is:

$$F_{ad} = \mu_{ad} \cdot F_{z1} = 0.9 \cdot 4395.6 = 3956.1 N$$

Splitting the tractive force between the front wheels, the resulting force complies with the condition of adhesion:

$$F_{tr} = 2985.3 N < F_{ad} = 3956.1 N$$

### 3.1.1.8 Highest Gear Ratio Calculation

With all the input parameters known, the highest gear ratio can be calculated. The tractive force can be expressed as:

$$F_{tr} = \frac{T \cdot i_c \cdot \eta_c}{r_d} \quad (10)$$

- $T$  is the input torque
- $i_c$  is the total gear ratio
- $\eta_c$  is the efficiency of the complete driveline
- $r_d$  is the wheel dynamic radius

The total gear ratio can therefore be expressed as:

$$i_c = \frac{F_{tr} \cdot r_d}{T \cdot \eta_c} \quad (11)$$

The gearbox uses a dual-clutch system and each electric motor is connected to a different input shaft. That means the input torque going into the input shaft with currently shifted speed comes from the internal combustion engine and one of the electric motors. The other electric motor delivers its torque through the other input shaft. For that reason, when undertaking the initial calculation of the gearbox spread, maximum torque from the ICE and one electric motor was considered. The input torque is therefore:

$$T = T_{ICE} + T_{EM} = 114 + 23 = 137 \text{ Nm}$$

The total gear ratio of the 1<sup>st</sup> speed is:

$$i_1 = \frac{F_{tr} \cdot r_d}{T \cdot \eta_c} = \frac{5970.7 \cdot 0.293}{137 \cdot 0.9} = 14.19$$

### 3.1.2 Lowest Gear Ratio

The lowest gear ratio was calculated regarding the requirement of reaching the vehicle top speed. Its value for the reference vehicle was set to 190 km/h (see 2.2.3).

#### 3.1.2.1 Lowest Gear Ratio Calculation

From the kinematic point of view, the speed of a vehicle can be calculated as:

$$v = r_d \cdot \omega_w = r_d \cdot \frac{2\pi n_w}{60} = \frac{\pi \cdot n_e \cdot r_d}{30 \cdot i_{tot}} \quad (12)$$

- $v$  is the vehicle speed [ $m \cdot s^{-1}$ ]
- $r_d$  is the dynamic wheel radius [ $m$ ]
- $\omega_w$  is the wheel rotational speed [ $rad \cdot s^{-1}$ ]
- $n_w$  is the wheel rotational speed [ $min^{-1}$ ]
- $n_e$  is the engine rotational speed [ $min^{-1}$ ]
- $i_{tot}$  is the selected total gear ratio [-]

In order to be able to insert the value of the vehicle speed in more common units (km/h), the equation is altered as follows:

$$v = \frac{\pi \cdot n_e \cdot r_d}{30 \cdot i_{tot}} \cdot \frac{3600}{1000} = \frac{0.377 \cdot n_e \cdot r_d}{i_{tot}} \quad (13)$$

Using the estimated top speed of 190 km/h, the lowest gear ratio equals:

$$i_{max} = \frac{0.377 \cdot n_e \cdot r_d}{190} = \frac{0.377 \cdot 6300 \cdot 0.293}{190} = 3.66$$

It is now necessary to check what the actual top speed of the vehicle could be when considering the resistances acting on the vehicle.

#### 3.1.2.2 Rolling Resistance

The calculation of the rolling resistance is the same as in 3.1.1.3, thus:

$$F_{roll} = m \cdot g \cdot f = 1813 \cdot 9.81 \cdot 0.011 = 195.6 \text{ N}$$

#### 3.1.2.3 Gradient Resistance

When considering reaching the top speed, the idea is that the car is driven on a level road. Therefore, the slope of the road is zero and so is the rolling resistance of the vehicle.

### 3.1.2.4 Acceleration Resistance

When the vehicle is reaching its top speed, it is possible to estimate its acceleration is close to zero. Considering that some acceleration is still needed to actually reach the top speed, acceleration data of the Ford Fiesta (2015 model for Europe) with the same Ford 1.25 DuraTec engine were used.

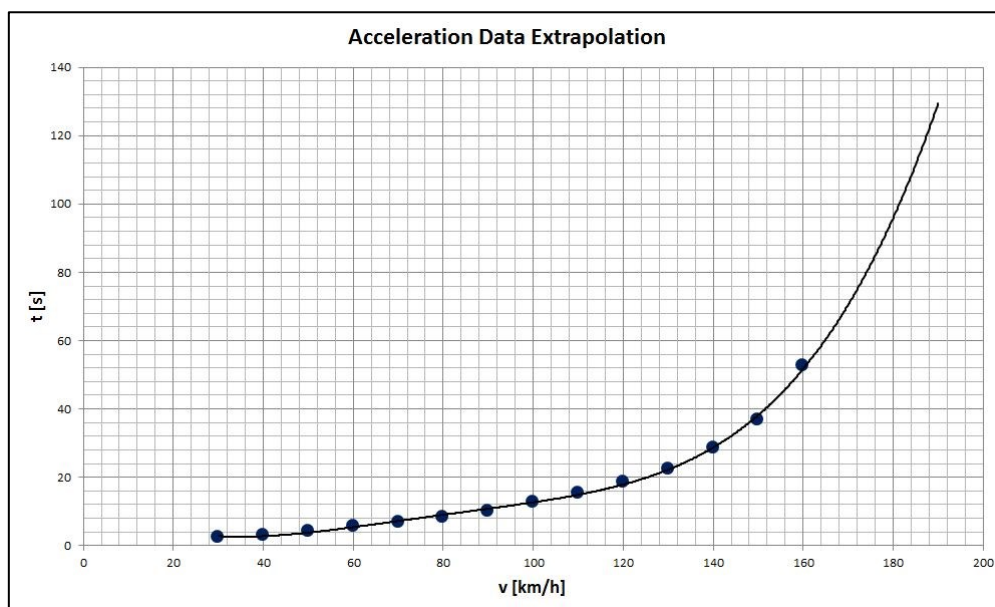

**Figure 6: Acceleration data of Ford Fiesta 1.25 DuraTec with extrapolation [3]**

The values beyond 160 km/h were extrapolated using a 4<sup>th</sup> grade polynomial. Linearizing the rise from 180 to 190 km/h, the acceleration was estimated at  $0.084 \text{ m/s}^2$ . The acceleration resistance could thus be calculated as:

$$F_{acc} = m \cdot a \cdot \delta = 1813 \cdot 0.084 \cdot 1.02 = 155.3 \text{ N}$$

### 3.1.2.5 Total Tractive Force

The total tractive force acting on the vehicle wheels is obtained as follows:

$$F_{tr} = \frac{T \cdot i_{max} \cdot \eta}{r_d} = \frac{137 \cdot 3.66 \cdot 0.9}{0.293} = 1541.3 \text{ N}$$

### 3.1.2.6 Top Speed Recalculation

The top speed is now recalculated from the air resistance:

$$F_{air} = F_{tr} - (F_{roll} + F_{grad} + F_{acc}) = 1541.3 - (195.6 + 0 + 155.3) = 1190.4 \text{ N}$$

$$F_{air} = \frac{1}{2} \cdot \rho_{air} \cdot c_x \cdot S_x \cdot v^2$$

$$v = \sqrt{\frac{2 \cdot F_{air}}{\rho_{air} \cdot c_x \cdot S_x}} = \sqrt{\frac{2 \cdot 1190.4}{1.2 \cdot 0.29 \cdot 2.23}} \text{ m} \cdot \text{s}^{-1} = 55.4 \text{ m} \cdot \text{s}^{-1} = 199.4 \text{ km} \cdot \text{h}^{-1}$$

The fact that the recalculated top speed is higher than the chosen one means the resistances are not a limiting factor for top speed as they would allow for even greater value than the one calculated via the kinematics of the driveline.

## 3.1.3 Gearbox Spread and Gear Steps Calculation

### 3.1.3.1 Total Gearbox Spread

The total gearbox spread is obtained as the ratio of the highest and lowest gears. It is therefore:

$$i_{Gtot} = \frac{i_1}{i_{max}} = \frac{14.19}{3.66} = 3.87 \quad (14)$$

### 3.1.3.2 Gear Steps Calculation

Gears in an automotive gearbox follow mathematical sequences. For the purposes of designing a gearbox for a passenger car, a progressive sequence is used. Its prescription is as follows:

$$q = \sqrt[z-1]{\frac{1}{q_2^{0.5 \cdot (z-1) \cdot (z-2)}} \cdot i_{Gtot}} \quad (15)$$

- $q$  is the base ratio change
- $q_2$  is the progression factor
- $z$  is the number of gearbox speeds

Values for the coefficient  $q_2$  lie in the range of 1.0 to 1.2. In this case,  $q_2 = 1.05$  was selected.

For the concept of this thesis, five and six-speed gearboxes were considered. In the end, since the vehicle in question is a small B-segment car and the idea of giving it a hybrid driveline means adding extra weight with electric motors, accumulators etc., the decision was made to pursue the five-speed solution, which enables to get rid not only of one gear pair but also its shifting mechanism.

With the five-speed layout, the base ratio is:

$$q = \sqrt[z-1]{\frac{1}{q_2^{0.5 \cdot (z-1) \cdot (z-2)}} \cdot i_{Gtot}} = \sqrt[5-1]{\frac{1}{1.05^{0.5 \cdot (5-1) \cdot (5-2)}} \cdot 3.87} = 1.30$$

Each gear step can now be calculated using the following equation:

$$i_n = i_z \cdot q^{(z-n)} \cdot q_2^{0.5 \cdot (z-n) \cdot (z-n-1)} \quad (16)$$

For the five-speed gearbox, the calculated gear steps are:

$$i_2 = i_5 \cdot 1.30^{(5-2)} \cdot 1.05^{0.5 \cdot (5-2) \cdot (5-2-1)} = 9.40$$

$$i_3 = i_5 \cdot 1.30^{(5-3)} \cdot 1.05^{0.5 \cdot (5-3) \cdot (5-3-1)} = 6.54$$

$$i_4 = i_5 \cdot 1.30^{(5-4)} \cdot 1.05^{0.5 \cdot (5-4) \cdot (5-4-1)} = 4.78$$

Calculated ratios are total ratios including final drives. In this dual-clutch concept, two final drives are used, one for the first output shaft, one for the second output shaft. Having two final drives gives opportunity to use two different ratios to the advantage of the specific design.

During the later design phase, final drive ratio values were proposed. They were based on the gearbox geometry. As will be mentioned in 3.2.3, the axial distance between the first output shaft and both input shafts was set. This distance determines space available for gear pairs mounted on the respective shafts and thus limits ratios possibly achievable on these gear pairs.

The first final drive was therefore used to complement the total ratios. The second final drive was selected with respect to the design of the 5<sup>th</sup> gear and the reverse gear. Various contradictory demands (such as gear ratios, the necessity to place an idler wheel to the reverse



gear assembly or space available) were needed to meet. The second final drive was therefore also tuned to appropriately complement the total ratios. Proposed values of final drives are:

$$i_{FD1} = 3.3; i_{FD2} = 4.5$$

The first final drive applies for the 1<sup>st</sup>, 2<sup>nd</sup>, 3<sup>rd</sup> and 4<sup>th</sup> gear, the second final drive for the 5<sup>th</sup> and reverse gear (see the following chapter 3.2). That gives following individual gear ratios:

$$i_n = \frac{i_{ntot}}{i_{FD}} \quad (17)$$

$$i_1 = \frac{i_{1tot}}{i_{FD1}} = \frac{14.19}{3.3} = 4.30$$

$$i_2 = \frac{i_{2tot}}{i_{FD1}} = \frac{9.40}{3.3} = 2.85$$

$$i_3 = \frac{i_{3tot}}{i_{FD1}} = \frac{6.54}{3.3} = 1.98$$

$$i_4 = \frac{i_{4tot}}{i_{FD1}} = \frac{4.78}{3.3} = 1.45$$

$$i_5 = \frac{i_{5tot}}{i_{FD2}} = \frac{3.66}{4.5} = 0.81$$

Calculated spread of the five-speed gearbox is shown in the so-called saw diagram:

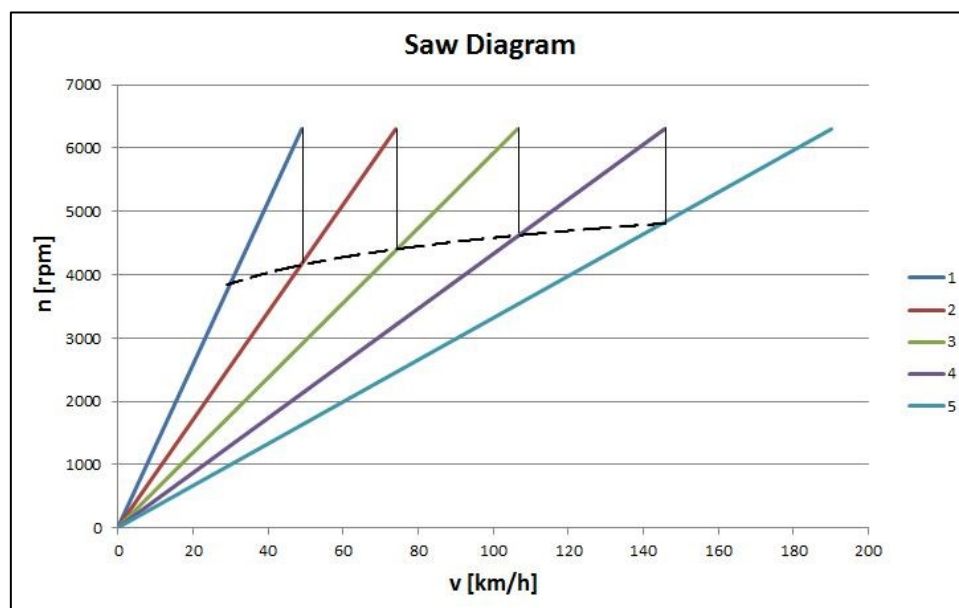

Figure 7: Proposed gear steps

The reverse gear ratio should be close to the 1<sup>st</sup> gear ratio, so that similar ability to drive off from a standstill is ensured also in the reversed direction. The calculation of the reverse gear ratio was carried out in the later design phase (see 3.2.4.6). Its proposed values are:

$$i_{Rtot} = 12.35$$

$$i_R = \frac{i_{Rtot}}{i_{FD2}} = \frac{12.35}{4.5} = 2.74$$

### 3.1.3.3 Downshift Check

It is necessary to check that the calculated gear steps are not too far apart. It means that when the vehicle is being driven with the engine running at the speed of its maximum torque and downshifting to the preceding lower gear is performed, the maximum rotational speed of the engine is not exceeded.

The maximum torque of the internal combustion engine is 114 Nm at 4200 rpm. When driving in 2<sup>nd</sup> gear, the respective vehicle speed is.

$$v_{2Tmax} = \frac{0.377 \cdot n_{Tmax} \cdot r_d}{i_2} = \frac{0.377 \cdot 4200 \cdot 0.293}{9.40} = 49.4 \text{ km/h}$$

When downshifting to 1<sup>st</sup> in such case, the rotational speed of the engine rises as follows:

$$n = \frac{v_{2Tmax} \cdot i_1}{0.377 \cdot r_d} = \frac{49.4 \cdot 14.19}{0.377 \cdot 0.293} = 6340 \text{ min}^{-1} > n_{max} = 6300 \text{ min}^{-1}$$

This means the ratio of the 1<sup>st</sup> gear needs to be modified accordingly. The value it must not exceed equals:

$$i_{1max} = \frac{0.377 \cdot n_{max} \cdot r_d}{v_{2Tmax}} = \frac{0.377 \cdot 6300 \cdot 0.293}{49.4} = 14.10$$

Necessary modifications are made in 3.2.4 when actual gear ratios are calculated.

Checking equivalent downshifts between following speeds results in:

$$v_{3Tmax} = \frac{0.377 \cdot n_{Tmax} \cdot r_d}{i_3} = \frac{0.377 \cdot 4200 \cdot 0.293}{6.54} = 71.0 \text{ km/h}$$

$$n = \frac{v_{3Tmax} \cdot i_2}{0.377 \cdot r_d} = \frac{71.0 \cdot 9.40}{0.377 \cdot 0.293} = 6038 \text{ min}^{-1} < n_{max} = 6300 \text{ min}^{-1}$$

$$v_{4Tmax} = \frac{0.377 \cdot n_{Tmax} \cdot r_d}{i_4} = \frac{0.377 \cdot 4200 \cdot 0.293}{4.78} = 97.1 \text{ km/h}$$

$$n = \frac{v_{4Tmax} \cdot i_3}{0.377 \cdot r_d} = \frac{97.1 \cdot 6.54}{0.377 \cdot 0.293} = 5750 \text{ min}^{-1} < n_{max} = 6300 \text{ min}^{-1}$$

$$v_{5Tmax} = \frac{0.377 \cdot n_{Tmax} \cdot r_d}{i_5} = \frac{0.377 \cdot 4200 \cdot 0.293}{3.66} = 126.7 \text{ km/h}$$

$$n = \frac{v_{5Tmax} \cdot i_4}{0.377 \cdot r_d} = \frac{126.7 \cdot 4.78}{0.377 \cdot 0.293} = 5476 \text{ min}^{-1} < n_{max} = 6300 \text{ min}^{-1}$$

## 3.2 Gearbox Layout

The basic idea of using a double-clutch transmission is to provide seamless-like gear changes. That is ensured by having odd- and even-numbered gears on different input shafts. For example, while the vehicle runs in the 1<sup>st</sup> gear (ICE connected to one input shaft via the clutch and the 1<sup>st</sup> speed shifted), it is possible to pre-shift the 2<sup>nd</sup> speed as it is mounted to the other input shaft, which has its part of the clutch still disengaged. Upshifting from 1<sup>st</sup> to 2<sup>nd</sup> gear is then done simply by simultaneously disengaging the first clutch and engaging the second one. That means the torque flow is never entirely interrupted. Another advantage of such system is also low demand on the time of selecting the next speed as it can be pre-shifted before the actual gear change even occurs.

### 3.2.1 Proposed Design

The proposed layout of the transmission is shown in the following figure:

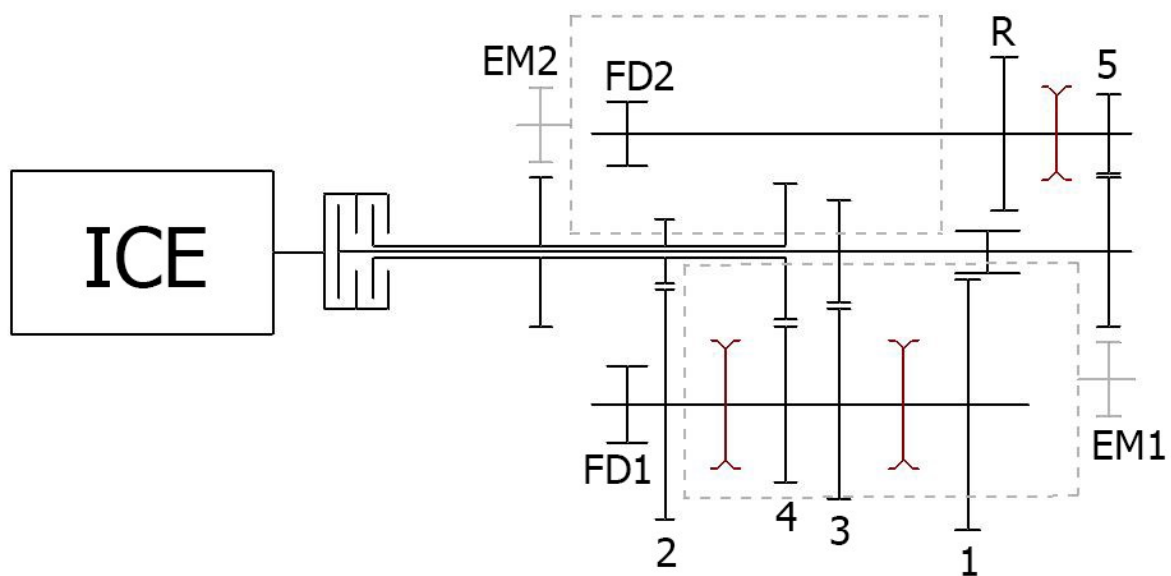

**Figure 8: Layout of the double-clutch gearbox with two electric motors**

The internal combustion engine is connected to the casing of the double clutch. Its friction plates are mounted to the first input shaft (solid) and the second input shaft (hollow) respectively.

The odd-numbered speeds use the first (solid) input shaft, while the even-numbered speeds use the second (hollow) input shaft. The first, second, third and fourth speeds lead to the first output shaft on which they can be selected with a shifting mechanism. The first output shaft also features the pinion of the first final drive which leads to the differential ring gear and to the driven wheels.

The fifth speed and the reverse speed direct the torque flow from the first input shaft onto the second output shaft, which has the pinion of the second final drive machined on it. The second final drive also leads to the differential ring gear and to the driven wheels.

Individual gears are shifted using shifting mechanisms mounted on the respective output shafts. One mechanism shifts the 1<sup>st</sup> and 3<sup>rd</sup> gear, another one shifts the 2<sup>nd</sup> and 4<sup>th</sup> gear and the last one shifts the 5<sup>th</sup> and R speed.

With electric motors permanently connected to the input shafts, use of conventional synchronisers was avoided. Instead, it was the electric motor themselves what is used to synchronise rotational speeds. The synchronisers were therefore substituted with simpler and lighter dog clutches.

First electric motor is connected to the first input shaft via a pinion on its own shaft, an idler gear and a gear wheel mounted on the first input shaft of the gearbox. The second electric motor also has a pinion on its own shaft and is connected to the gearbox with the use of an idler gear and a gear wheel on the second input shaft.

### **3.2.2 Proposed Shifting Strategy**

The proposed design allows for various shifting strategies. However, as that in itself is a complex problematic, detailed alternatives are not provided in this thesis.

A simple shifting strategy could be imagined. Using the basic idea behind the double-clutch transmission system, when a gear is selected, the next speed is already pre-shifted. That means when the 1<sup>st</sup> speed is shifted, torque flows from the internal combustion engine through the clutch onto the first input shaft. Extra torque is provided by the first electric motor geared to the same input shaft. The resulting torque is then transmitted through the 1<sup>st</sup> speed onto the first output shaft and through the first final drive onto the driven wheels. Meanwhile, the second electric motor helps to synchronise the rotational speed of the second gear with the

first output shaft, the 2<sup>nd</sup> speed is pre-shifted and the second electric motor produces more extra torque that flows to the driven wheels.

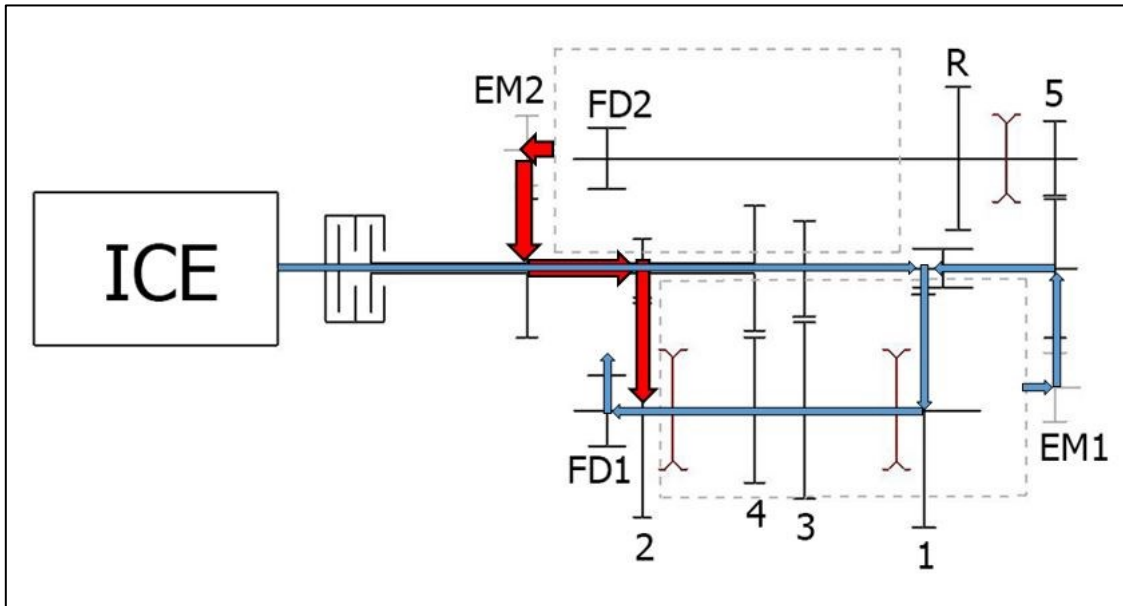

**Figure 9: Vehicle driving in the 1st gear**

When the 2<sup>nd</sup> speed is shifted (main torque flow from the ICE and EM2), the 3<sup>rd</sup> gear is pre-selected and with its use, extra torque is provided from the first electric motor.

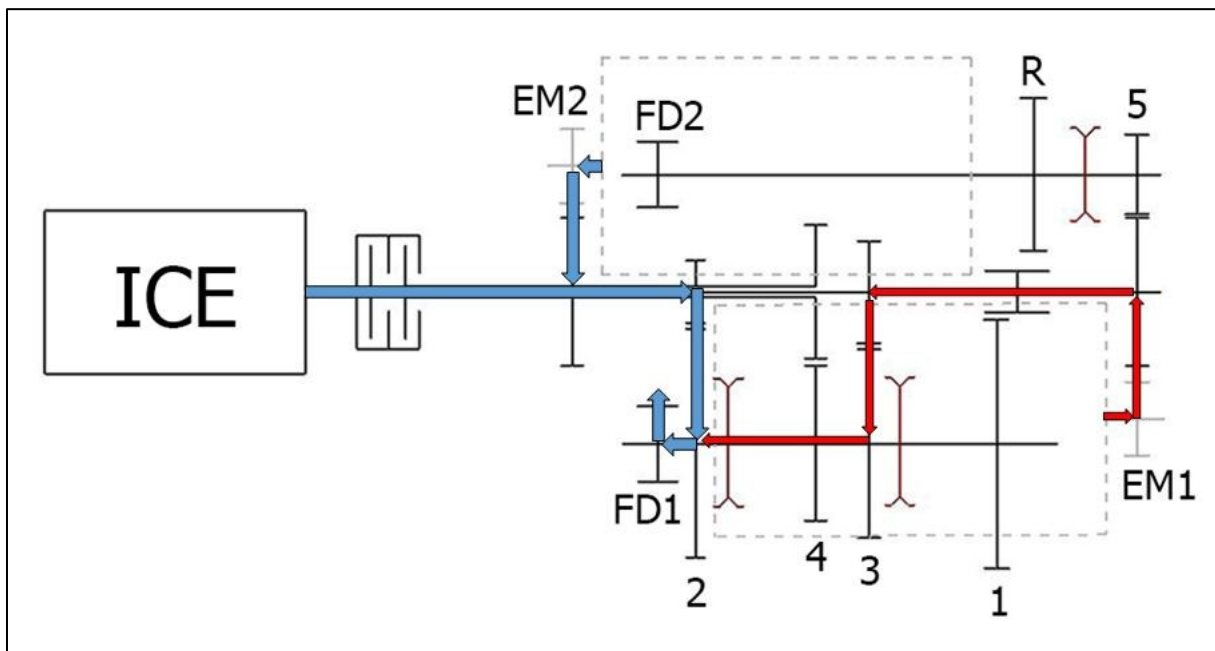

**Figure 10: Vehicle driving in the 2nd gear**

When the 3<sup>rd</sup> speed is shifted (main torque flow from the ICE and EM1), the 4<sup>th</sup> gear is pre-selected and with its use, extra torque is provided from the second electric motor.

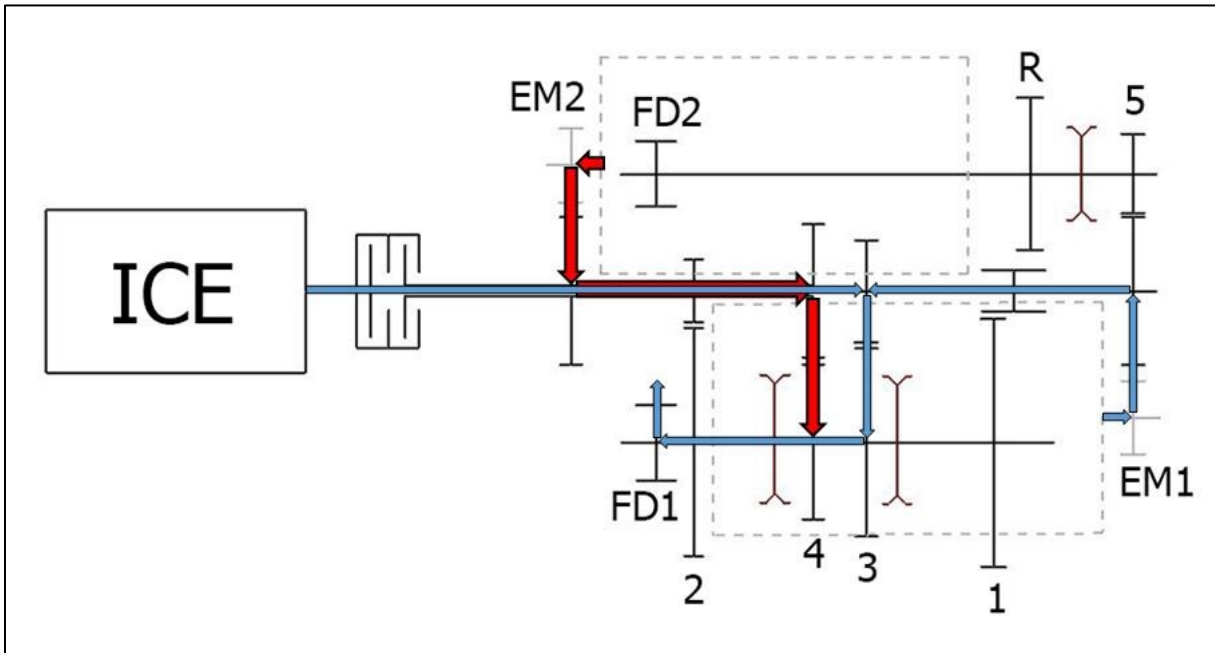

Figure 11: Vehicle driving in the 3rd gear

When the 4<sup>th</sup> speed is shifted (main torque flow from the ICE and EM2), the 5<sup>th</sup> gear is pre-selected and with its use, extra torque is provided from the first electric motor.

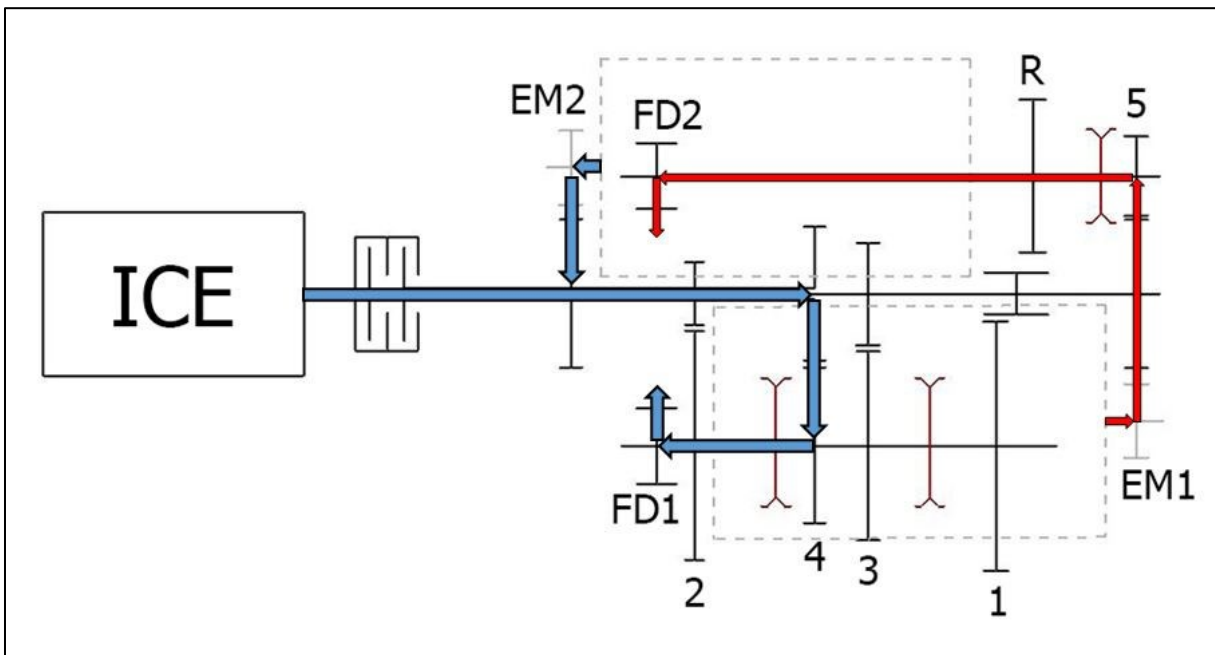
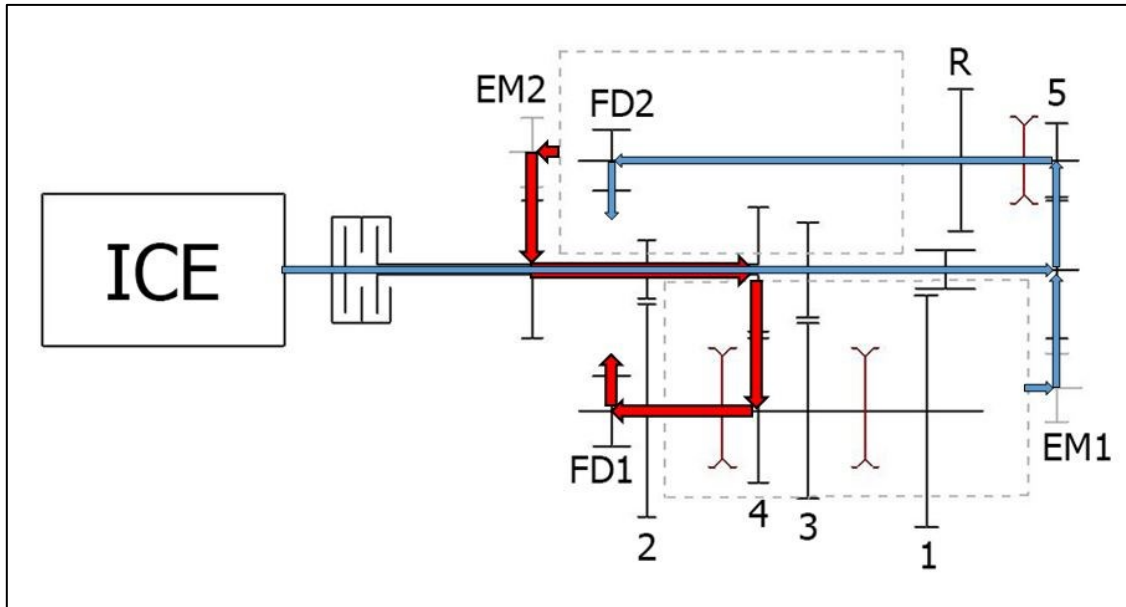

Figure 12: Vehicle driving in the 4th gear

When the 5<sup>th</sup> speed is shifted (main torque flow from the ICE and EM1), the 4<sup>th</sup> gear is pre-selected and with its use, extra torque is provided from the second electric motor. For upshifting from 4<sup>th</sup> to 5<sup>th</sup>, no actual gear shifting is needed. Simply, the clutch for the first input shaft (solid) engages while the clutch for the second input shaft (hollow) disengages.



**Figure 13: Vehicle driving in the 5th gear**

For the reverse gear, the design with two electric motors can also be used. While the reverse gear is shifted (main torque flow from the ICE and EM1), the 2<sup>nd</sup> gear is also selected and with its use, extra torque flow is provided from the second electric motor.

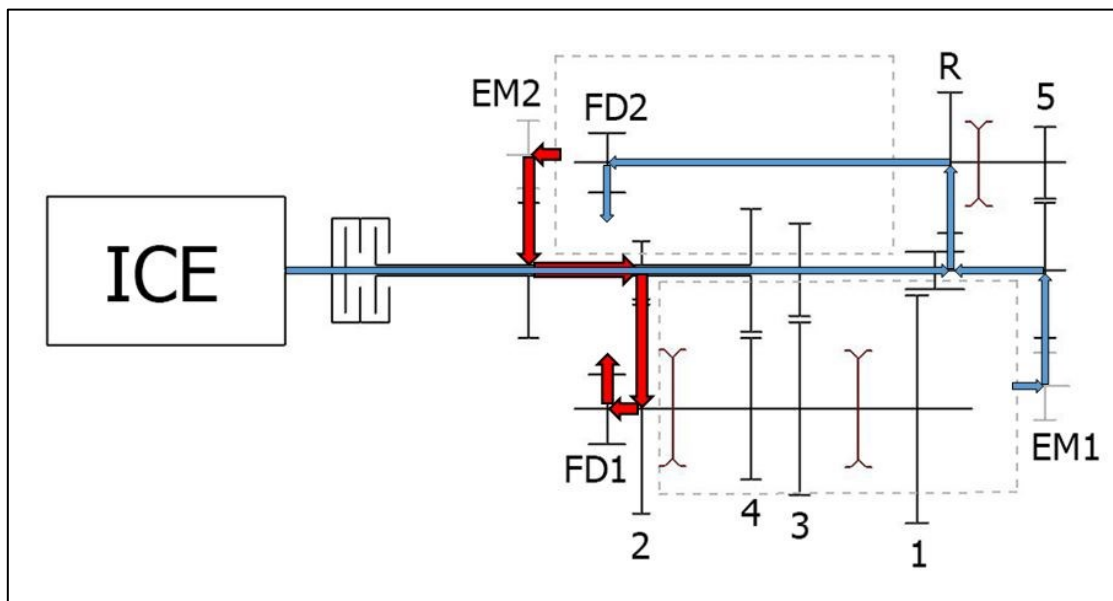

**Figure 14: Vehicle driving in the reverse gear**



### 3.2.3 Parameters of Gear Pairs

Actual gear ratios cannot precisely follow the proposed steps calculated in 3.1 because in reality their values are determined by geometrical parameters. Each gear wheel has an integer number of teeth. It is the numbers of teeth of the two gear wheels in each gear pair that give the actual gear ratio.

$$i = \frac{z_2}{z_1} \quad (18)$$

For each gear pair, the number of teeth of its pinion was selected [source]. Using the (18) equation, the number of teeth of the gear wheel was calculated as:

$$z_2 = i \cdot z_1$$

This number was rounded off to an integer figure. The actual gear ration of each speed was then recalculated.

For the position of the first output shaft with respect to the input shafts, the axial distance was set to  $a_1 = 80 \text{ mm}$ . This distance was then divided for each speed with respect to its ratio using following relations:

$$a_1 = \frac{d_1 + d_2}{2} \quad (19)$$

$$d_2 = i \cdot d_1 \quad (20)$$

Combining (19) and (20) gives relations between the axial distance, the gear ratio and pitch diameters of gear wheels:

$$d_1 = \frac{2a_1}{1 + i} \quad (21)$$

$$d_2 = \frac{2a_1}{\frac{1}{i} + 1} \quad (22)$$

Choosing the angle of helix [2] for each gear pair allows calculating normal module for each speed using following equations:

$$m_t = \frac{d}{z} \quad (23)$$

$$m_n = m_t \cdot \cos \beta \quad (24)$$

- $d$  is the pitch diameter
- $z$  is the number of teeth
- $\beta$  is the helix angle
- $m_t$  is the transverse module
- $m_n$  is the normal module

### 3.2.4 Dimensions of Gear Pairs

Using [2] and the equations from 3.3.1, dimensions of gear wheels in each gear pair for the use of the 3D concept were calculated.

#### 3.2.4.1 1<sup>st</sup> Gear

For the 1<sup>st</sup> speed, the dimensions are:

$$i_l = 4.30$$

$$z_{I1} = 13$$

$$z_{I2} = i_l \cdot z_{I1} = 4.30 \cdot 13 = 55.89$$

To meet the condition of the downshift check introduced in 3.1.3.3, the number of teeth of the 1<sup>st</sup> speed output wheel was set to  $z_{I2} = 55$ , hence the actual ratio of the 1<sup>st</sup> speed is:

$$i_l = \frac{z_{I2}}{z_{I1}} = \frac{55}{13} = 4.23$$

The remaining parameters are:

$$d_{I1} = \frac{2a_1}{1 + i_l} = \frac{2 \cdot 80}{1 + 4.23} = 30.59 \text{ mm}$$

$$d_{I2} = \frac{2a_1}{\frac{1}{i_l} + 1} = \frac{2 \cdot 80}{\frac{1}{4.23} + 1} = 129.41 \text{ mm}$$

$$\beta_I = 10^\circ$$

$$m_{tI} = \frac{d_{I1}}{z_{I1}} = \frac{d_{I2}}{z_{I2}} = \frac{30.59}{13} = 2.35 \text{ mm}$$

$$m_{nI} = m_{tI} \cdot \cos \beta_I = 2.35 \cdot \cos 10^\circ = 2.32 \text{ mm}$$

### 3.2.4.2 2<sup>nd</sup> Gear

For the 2<sup>nd</sup> speed, the parameters are:

$$i_{II} = 2.85$$

$$z_{II1} = 18$$

$$z_{II2} = i_{II} \cdot z_{II1} = 2.85 \cdot 18 = 51.27 \rightarrow z_{II2} = 51$$

$$i_{II} = \frac{z_{II2}}{z_{II1}} = \frac{51}{18} = 2.83$$

$$d_{II1} = 41.74 \text{ mm}; d_{II2} = 118.26 \text{ mm}$$

$$\beta_{II} = 20^\circ; m_{tII} = 2.32 \text{ mm}; m_{nII} = 2.18 \text{ mm}$$

### 3.2.4.3 3<sup>rd</sup> Gear

For the 3<sup>rd</sup> speed, the parameters are:

$$i_{III} = 1.98$$

$$z_{III1} = 25$$

$$z_{III2} = i_{III} \cdot z_{III1} = 1.98 \cdot 25 = 49.53 \rightarrow z_{III2} = 50$$

$$i_{III} = \frac{z_{III2}}{z_{III1}} = \frac{50}{25} = 2$$

$$d_{III1} = 53.33 \text{ mm}; d_{III2} = 106.67 \text{ mm}$$

$$\beta_{III} = 20^\circ; m_{tIII} = 2.13 \text{ mm}; m_{nIII} = 2.00 \text{ mm}$$

### 3.2.4.4 4<sup>th</sup> Gear

For the 4<sup>th</sup> speed, the parameters are:

$$i_{IV} = 1.45$$

$$z_{IV1} = 34$$

$$z_{IV2} = i_{IV} \cdot z_{IV1} = 1.45 \cdot 34 = 49.21 \rightarrow z_{IV2} = 49$$

$$i_{IV} = \frac{z_{IV2}}{z_{IV1}} = \frac{49}{34} = 1.44$$

$$d_{IV1} = 65.54 \text{ mm}; d_{IV2} = 94.46 \text{ mm}$$

$$\beta_{IV} = 25^\circ; m_{tIV} = 1.93 \text{ mm}; m_{nIV} = 1.75 \text{ mm}$$

### 3.2.4.5 5<sup>th</sup> Gear

Considering the 5<sup>th</sup> speed as the one used for cruising at the maximum speed of 130 km/h allowed on motorways in the Czech Republic, the ratio was modified to avoid the engine being revved at too high rotational speed.

With the previously calculated ratio, the engine would reach the following speed:

$$n = \frac{i_5 \cdot v}{0.377 \cdot r_d} = \frac{3.66 \cdot 130}{0.377 \cdot 0.293} = 4311 \text{ min}^{-1}$$

Lowering the target engine speed at 130 km/h to 3900 rpm, the ratio of the 5<sup>th</sup> speed changes to:

$$i_5 = \frac{0.377 \cdot n \cdot r_d}{v} = \frac{0.377 \cdot 3900 \cdot 0.293}{130} = 3.31$$

Repeating the downshift check for the modified ratio gives:

$$v_{5Tmax} = \frac{0.377 \cdot n_{Tmax} \cdot r_d}{i_5} = \frac{0.377 \cdot 4200 \cdot 0.293}{3.31} = 140.0 \text{ km/h}$$

$$n = \frac{v_{5Tmax} \cdot i_4}{0.377 \cdot r_d} = \frac{140 \cdot 4.78}{0.377 \cdot 0.293} = 6055 \text{ min}^{-1} < n_{max} = 6300 \text{ min}^{-1}$$

The parameters are therefore:

$$i_V = 0.74$$

$$z_{V2} = 32$$

$$z_{V2} = i_V \cdot z_{V1} = 0.74 \cdot 32 = 23.57 \rightarrow z_{V2} = 24$$

$$i_V = \frac{z_{V2}}{z_{V1}} = \frac{24}{32} = 0.75$$

$$d_{V1} = 71.44 \text{ mm}; d_{V2} = 53.58 \text{ mm}$$

The axial distance between the input shafts and the second output shaft is then:

$$a_2 = \frac{d_{V1} + d_{V2}}{2} = \frac{71.44 + 53.58}{2} = 62.51 \text{ mm}$$

The remaining parameters of the 5<sup>th</sup> speed are as follows:

$$\beta_V = 25^\circ; m_{tV} = 2.23 \text{ mm}; m_{nV} = 2.02 \text{ mm}$$

### 3.2.4.6 Reverse Gear

The reverse gear uses the pinion of the 1<sup>st</sup> speed, hence the wheels share multiple parameters of the 1<sup>st</sup> speed. They are:

$$i_r = 2.74$$

$$z_{r1} = z_{I1} = 13$$

$$z_{r2} = i_r \cdot z_{r1} = 2.74 \cdot 13 = 35.66 \rightarrow z_{r2} = 36$$

$$i_r = \frac{z_{r2}}{z_{r1}} = \frac{36}{13} = 2.77$$

$$d_{r1} = 30.59 \text{ mm}; d_{r2} = 84.71 \text{ mm}$$

$$\beta_r = 10^\circ; m_{tr} = 2.35 \text{ mm}; m_{nr} = 2.32 \text{ mm}$$

As for the idler wheel:

$$z_{ri} = 19; d_{ri} = 44.71 \text{ mm}$$

### 3.2.4.7 Final Drive 1

The parameters of the first final drive are:

$$i_{FDI} = 3.3$$

$$z_{FDI1} = 20$$

$$z_{FDI2} = i_{FDI} \cdot z_{FDI1} = 3.3 \cdot 20 = 66$$

$$d_{FDI1} = 54 \text{ mm}; d_{FDI2} = 178.2 \text{ mm}$$

$$\beta_{FDI} = 25^\circ; m_{tFDI} = 2.7 \text{ mm}; m_{nFDI} = 2.45 \text{ mm}$$

### 3.2.4.8 Final Drive 2

Both final drives share the same output wheel. The parameters of the second final drive are:

$$i_{FDII} = 4.5$$

$$z_{FDII2} = 66$$

$$z_{FDII1} = \frac{z_{FDII2}}{i_{FDII}} = \frac{66}{4.5} = 14.67 \rightarrow z_{FDII1} = 15$$

$$i_{FDII1} = \frac{z_{FDII2}}{z_{FDII1}} = \frac{66}{15} = 4.4$$

$$d_{FDII1} = 40.5 \text{ mm}; d_{FDII2} = 178.2 \text{ mm}$$

$$\beta_{FDII} = 25^\circ; m_{tFDII} = 2.7 \text{ mm}; m_{nFDII} = 2.45 \text{ mm}$$

### 3.2.4.9 Electric Motor 1

The first electric motor is connected to the gearbox via a pinion on its own shaft, an idler wheel and the gear wheel on the first input shaft used for the 5<sup>th</sup> speed. It therefore shares multiple parameters.

The gear ratio is equal to the gear ratio of the second electric motor. The process of its calculation is described in 3.2.4.10.

The parameters of the gearing of the first electric motor are:

$$i_{EMI} = 1.28$$

$$z_{EMI1} = 25; z_{EMIi} = 27; z_{EMI2} = 32$$

$$d_{EMI1} = 55.81 \text{ mm}; d_{EMIi} = 60.28 \text{ mm}; d_{EMI2} = 71.44 \text{ mm}$$

$$\beta_{EMI} = 25^\circ; m_{tEMI} = 2.23 \text{ mm}; m_{nEMI} = 2.02 \text{ mm}$$

### 3.2.4.10 Electric Motor 2

The second electric motor is connected to the gearbox via a pinion wheel on its own shaft, an idler wheel and the gear wheel on the second input shaft.

The gear ratio is selected with the intention of maximum torque multiplication to ensure the greatest contribution of the electric motor to the hybrid system. However, its value

is limited by the necessity to avoid exceeding the maximum permissible rotational speed of the motor. Its value is  $n_{EMmax} = 12000 \text{ min}^{-1}$ .

The electric motor comes closest to exceeding its maximum rotational speed when the vehicle runs in 5<sup>th</sup> gear, in the situation when the internal combustion engine is revved to its maximum of 6300 rpm. The kinematic path of this case is shown in the following figure:

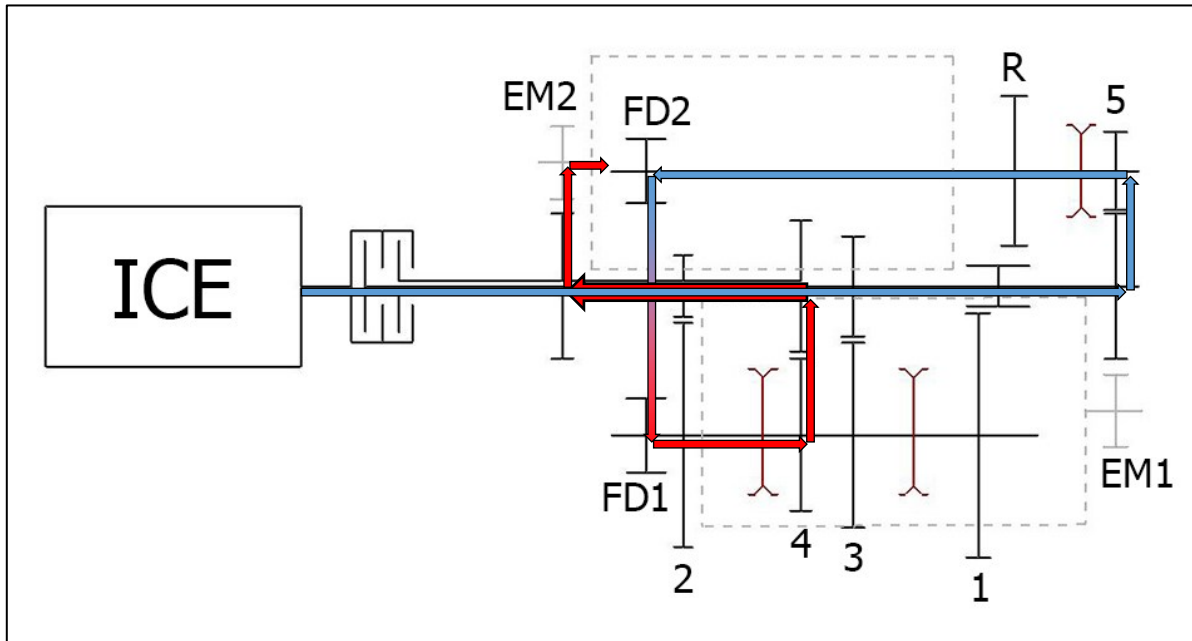

**Figure 15: Kinematic path from ICE to EM2**

The critical ratio of the electric motor is given by this equation:

$$i_{cr} = \frac{n_{EMmax} \cdot i_V \cdot i_{FDII}}{n_{ICEmax} \cdot i_{FDI} \cdot i_{IV}} \quad (25)$$

$$i_{cr} = \frac{12000 \cdot 0.75 \cdot 4.4}{6300 \cdot 3.3 \cdot 1.44} = 1.32$$

$$z_{EMII2} = 32$$

$$z_{EMII1} = \frac{z_{EMII2}}{i_{cr}} = \frac{32}{1.32} = 24 \rightarrow z_{EMII1} = 25$$

$$i_{EMII} = \frac{z_{EMII2}}{z_{EMII1}} = \frac{32}{25} = 1.28$$

$$z_{EMIIi} = 27$$

$$d_{EMII1} = 55.81 \text{ mm}; d_{EMIIi} = 60.28 \text{ mm}; d_{EMII2} = 71.44 \text{ mm}$$

$$\beta_{EMII} = 25^\circ; m_{tEMII} = 2.23 \text{ mm}; m_{nEMII} = 2.02 \text{ mm}$$

### 3.2.5 Actual Gear Ratios

Using the final dimensions determined during the design of the 3D concept, the actual gear ratios were calculated. They are as follows:

$$i_{FD1} = 3.3$$

$$i_{FD2} = 4.4$$

$$i_1 = i_I \cdot i_{FD1} = 4.23 \cdot 3.3 = 13.96$$

$$i_2 = i_{II} \cdot i_{FD1} = 2.83 \cdot 3.3 = 9.35$$

$$i_3 = i_{III} \cdot i_{FD1} = 2.00 \cdot 3.3 = 6.60$$

$$i_4 = i_{IV} \cdot i_{FD1} = 1.44 \cdot 3.3 = 4.76$$

$$i_5 = i_V \cdot i_{FD2} = 0.75 \cdot 4.4 = 3.30$$

$$i_R = i_r \cdot i_{FD2} = 2.77 \cdot 4.4 = 12.18$$

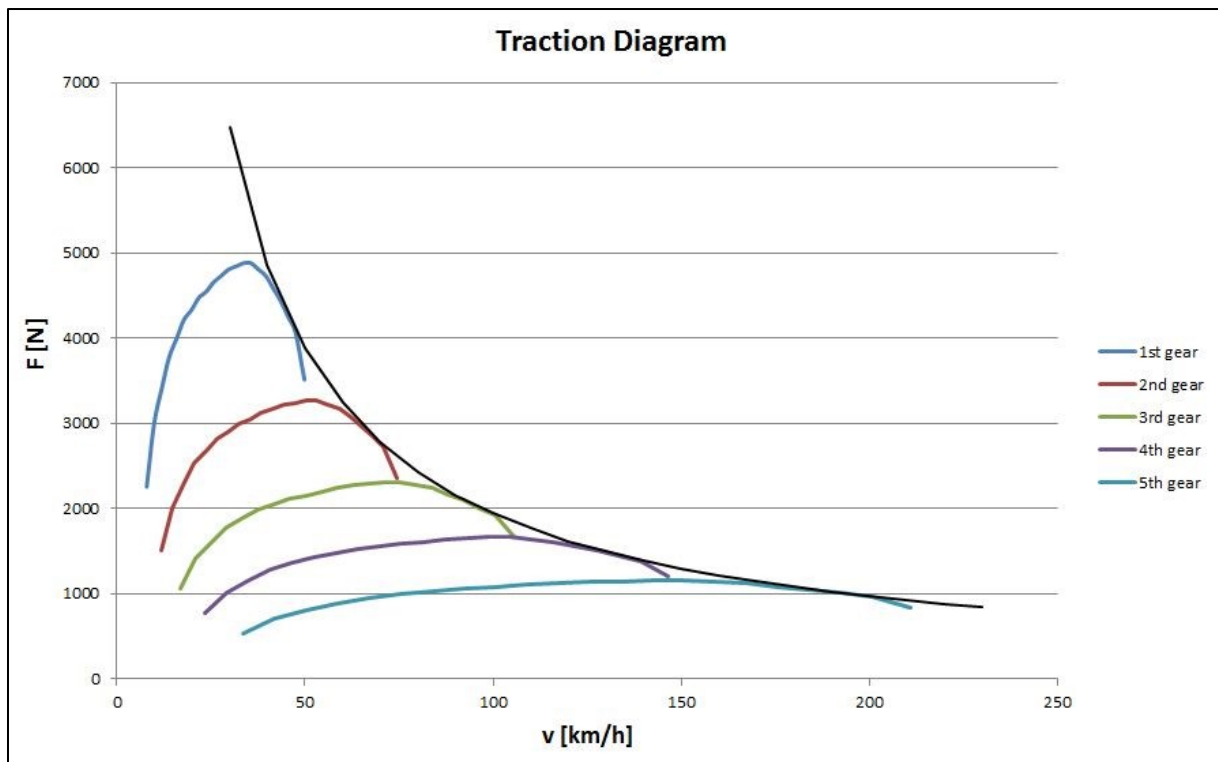

Figure 16: Traction diagram of the proposed gearbox



## 3.3 3D CAD Concept

### 3.3.1 3D CAD Concept

With all the necessary dimensions selected and calculated, a 3D CAD concept was created using the Catia V5 software. The model shows the proposed design in further details, suggesting a possible construction solution with relative positions of individual components, selected bearings etc. and forms the basis for the subsequent duty cycle load simulation.

The 3D design overview is shown in the following figure:

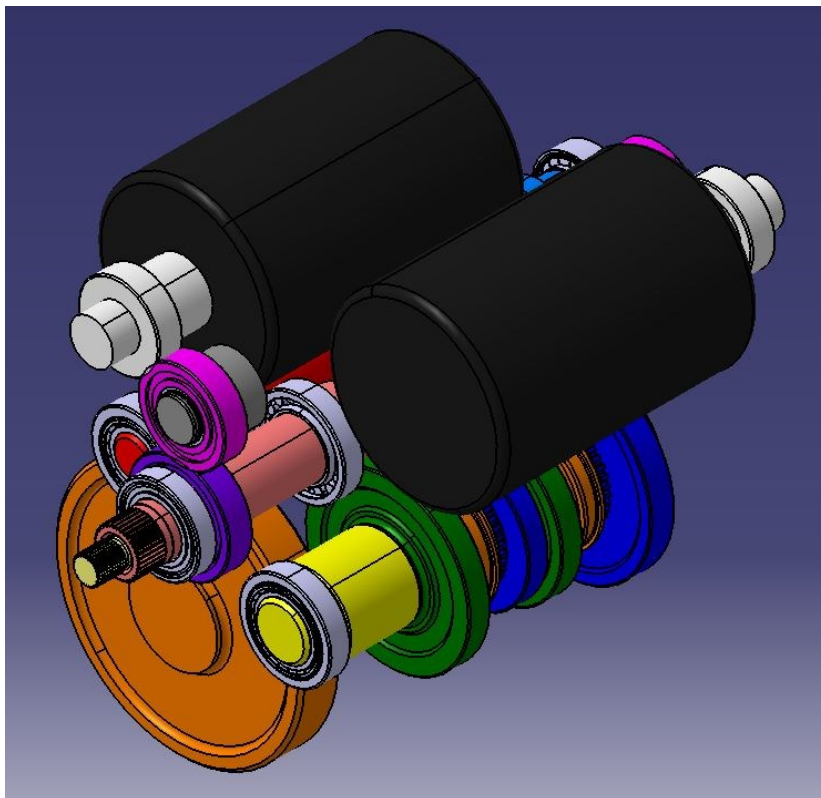

**Figure 17: 3D concept overview**

The main features and the overall layout are shown in the cross-section led through both input and both output shafts:

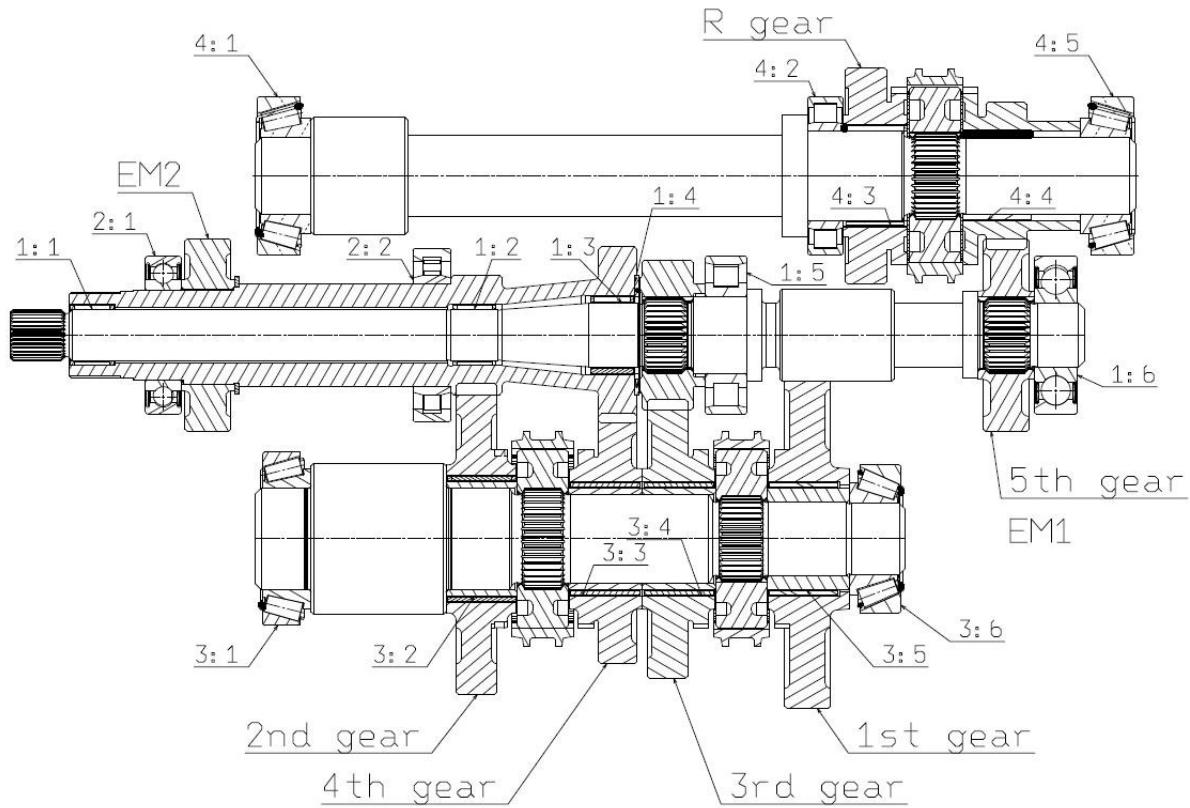

**Figure 18: Cross section through input and output shafts**

Fig.16 shows the labelling scheme used to denote bearings. This system follows the labelling scheme applied to the SABR computational model (see 4.2). The first figure denotes the shaft supported by the bearing, the second figure denotes bearings (numbered from the side of the combustion engine). Listed below are types of bearings used in the concept.

1) Input shaft 1 (solid)

- 1:1-3 needle bearings
- 1:4 axial roller bearing
- 1:5 roller bearing
- 1:6 ball bearing

2) Input shaft 2 (hollow)

- 2:1 ball bearing

- 2:2 roller bearing
- 3) Output shaft 1
  - 3:1,6 taper roller bearings
  - 3:2-5 needle bearings
- 4) Output shaft 2
  - 4:1,5 taper roller bearings
  - 4:2 roller bearing
  - 4:3-4 needle bearings

*Note: Results table in 4.2 features more bearings than listed here. They are extra bearings needed for correct operation of the computational model.*

Following side view shows relative positions of axes of individual shafts and the positioning of the gearbox with respect to the vehicle orientation:

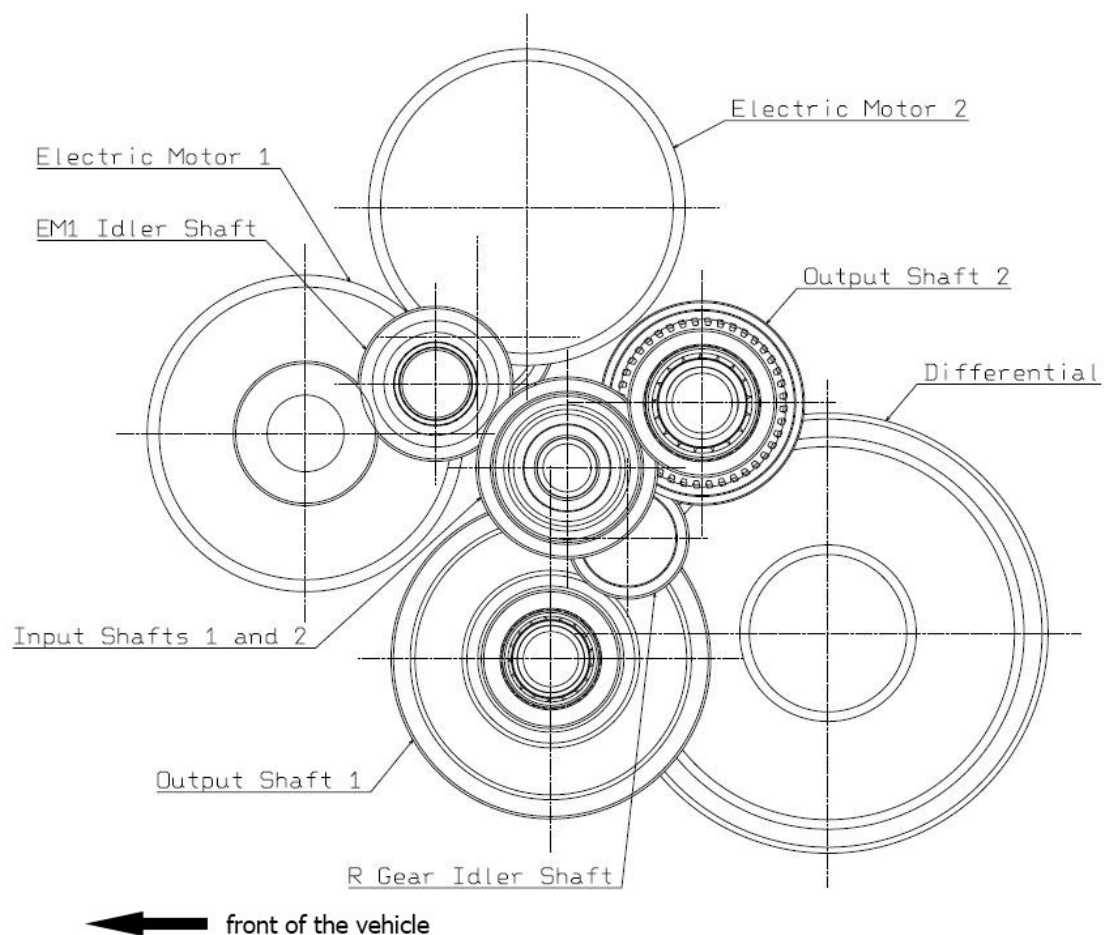

**Figure 19: Positioning of the gearbox in relation to the vehicle orientation**

## 4 Load Cycle Simulation

The 3D concept proposed in 3.3 was subsequently tested in a load cycle simulation. For this purpose, Ricardo developed SABR software was used. A duty cycle was created to simulate conditions a B-segment car could go through in its life. A computational model was created and simulation performed to check the durability of the proposed design.

### 4.1 Duty Cycle

Prior to the load simulation, a duty cycle was created. As duty cycles are usually a secret know-how of car makers, data for the purpose of this thesis were estimated and modified under supervision of Ricardo engineers.

The prerequisite for the cycle creation was an assumption that the gearbox is designed for 150 000 km. With an average speed of 50 km/h, this makes for 3000 hours of use. This period was distributed among individual gears as shown:

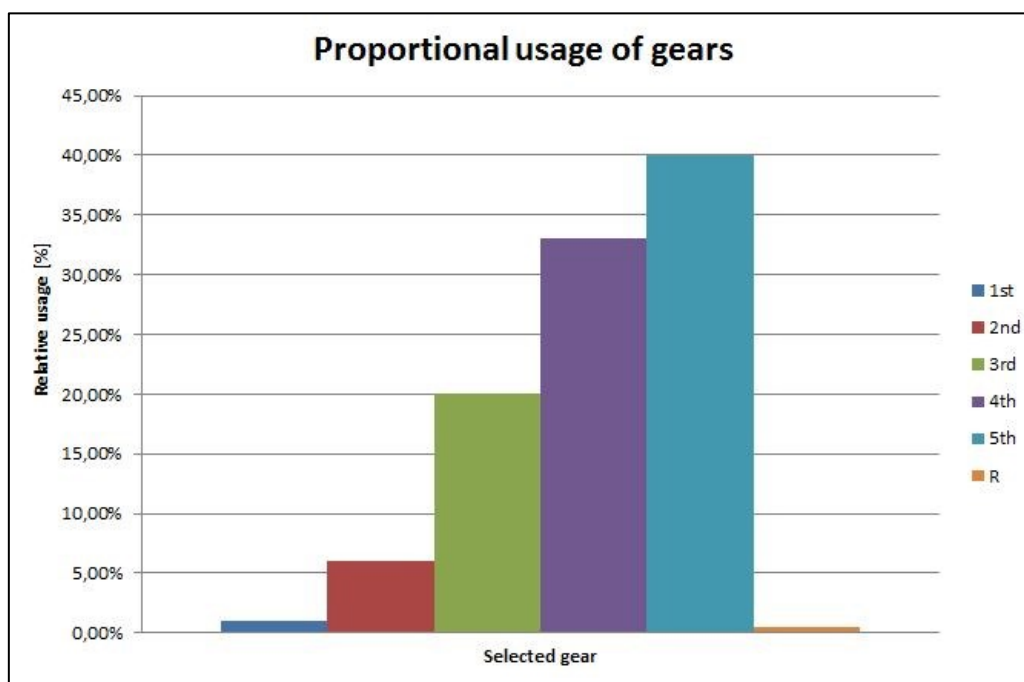

**Figure 20: Proportional usage of gears**

*Source: Ricardo*

## 4.2 SABR Simulation

The designed gearbox concept was transformed into a computational model for the SABR software. Load cases for individual gears (respecting the shifting strategy shown in 3.2.2) were created and the load cycle simulation was performed.

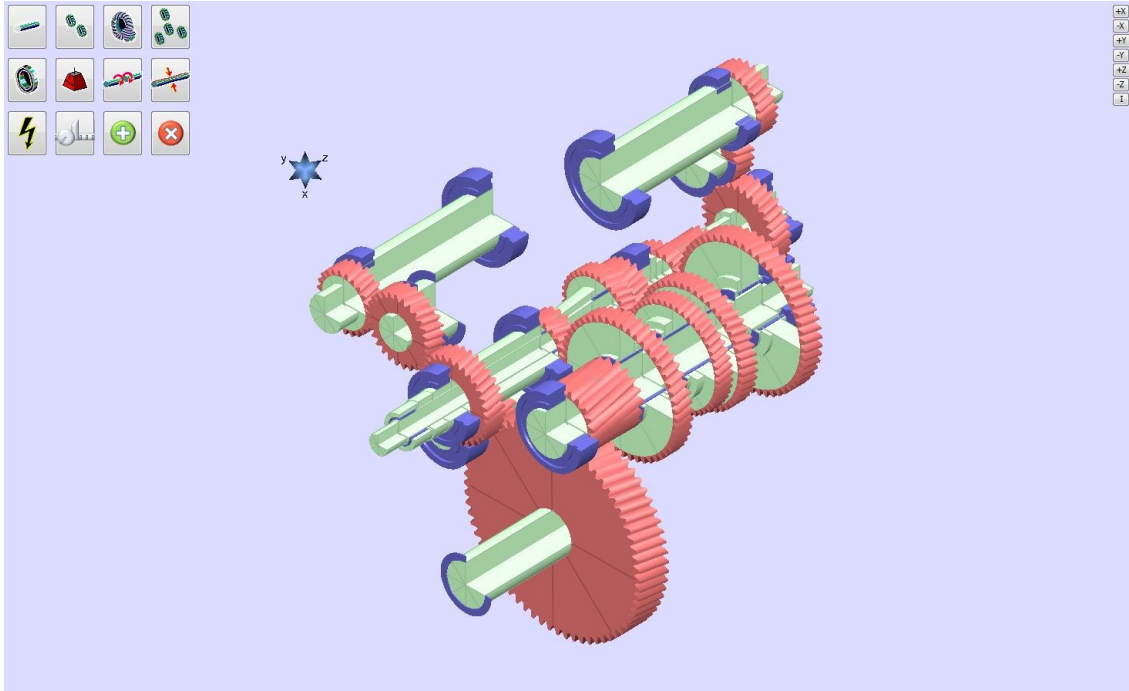

Figure 21: SABR model of proposed gearbox concept

### 4.2.1 Bearing Life

The following table shows damage done to bearings during the load cycle. The damage limit that must not be exceeded represents 100%. Each bearing has its proportional damage listed in the table to see the impact of the load cycle:

Main Shaft Bearings - Total Damage Across Duty Cycle										
		Damage Limit (%)	Misalignment Limit			Include Lubrication	Show 2007 Failure Rate			
Bearing	Type	Results	Life (hrs)	Detailed Damage	Graph	Failure Rate	Tilt (mrad)	Speed	Max. Stress	Profile
3.5	CE NEEDLE	ok	574075417347	0.0%		0 ppm	1.80	✓	2.511	ISO
3.4	CE NEEDLE	ok	748771238616	0.0%		0 ppm	1.18	✓	1.783	ISO
3.3	CE NEEDLE	ok	400702384693	0.0%		0 ppm	1.01	✓	1.651	ISO
3.2	CE NEEDLE	ok	334739494611	0.0%		0 ppm	1.45	✓	2.167	ISO
4.3	CE NEEDLE	ok	565835658977	0.0%		0 ppm	1.37	✓	2.260	ISO
4.4	CE NEEDLE	ok	229177035923	0.0%		0 ppm	0.73	✓	1.713	ISO
1.1	CE NEEDLE	ok	10840214924.8	0.0%		0 ppm	0.77	✓	0.663	ISO
1.2	CE NEEDLE	ok	28490.0	3.8%		0 ppm	0.46	✓	1.432	ISO
1.3	CE NEEDLE	ok	1624.6	67.3%		5.4%	0.98	✓	2.128	ISO
3.1	TAPER	ok	2163.6	50.6%		3.4%	0.69	✓	2.408	ISO
3.6	TAPER	ok	8862.8	12.3%		0.2%	0.87	✓	1.972	ISO
4.1	TAPER	ok	28903.3	3.8%		0 ppm	1.35	✓	2.274	ISO
4.5	TAPER	ok	1646506.7	0.1%		0 ppm	0.61	✓	1.222	ISO
1.6	DG BALL	ok	1746.0	62.7%		4.9%	1.56	✓	2.853	n/a
1.4	THRUST ROLLER	ok	94389075.4			0 ppm	1.14	✓	n/a	n/a
2.1	DG BALL	ok	45539.2	2.4%		0 ppm	0.30	✓	2.005	n/a
7.2	DG BALL	ok	191748.4	0.6%		0 ppm	0.26	✓	1.812	n/a
7.1	ROLLER	ok	10199788902.2	0.0%		0 ppm	0.24	✓	0.531	ISO
8.1	DG BALL	ok	83920.6	1.3%		0 ppm	0.29	✓	1.895	n/a
8.2	ROLLER	ok	1638539531.5	0.0%		0 ppm	0.26	✓	0.635	ISO
1.5	ROLLER	ok	21533.0	5.1%		3 ppm	1.19	✓	2.127	ISO
2.2	ROLLER	ok	8867.1	12.3%		0.2%	0.47	✓	2.089	ISO
4.2	ROLLER	ok	142738.0	0.8%		0 ppm	0.72	✓	1.855	ISO

Table 3: Bearing life

As can be seen, the 1:3 bearing (needle bearing between input shafts under the 4<sup>th</sup> speed) took the worst damage (67.3%), but it is still well within the damage limit. The 1:6 bearing (ball bearing on the input shaft 1 end) was damaged to 62.7%, the 3:1 (taper roller bearing on the first output shaft next to the final drive pinion) was damaged to 50.6%.

### 4.2.2 Shaft Deflections

The load cycle simulation also tested deflections of shafts. The results of the worst cases for each input shaft and each output shaft are shown.

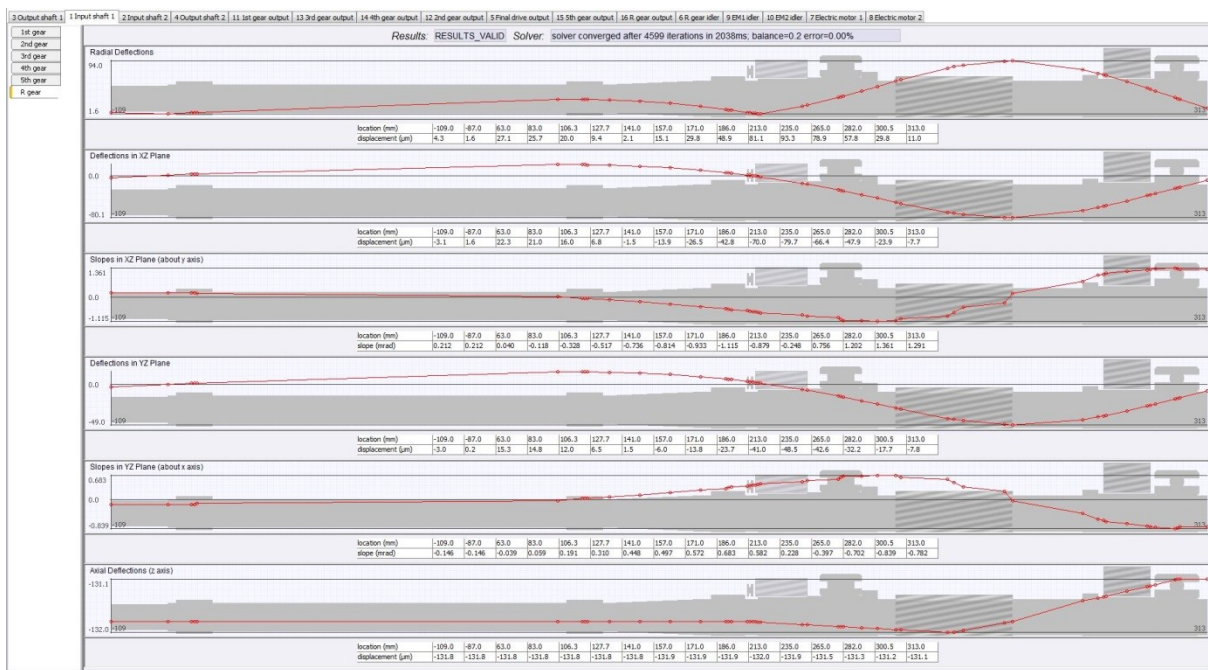

Figure 22: Input shaft 1 deflections in R gear

Maximum radial deflection of the input shaft 1 in reverse gear reached 94 µm.

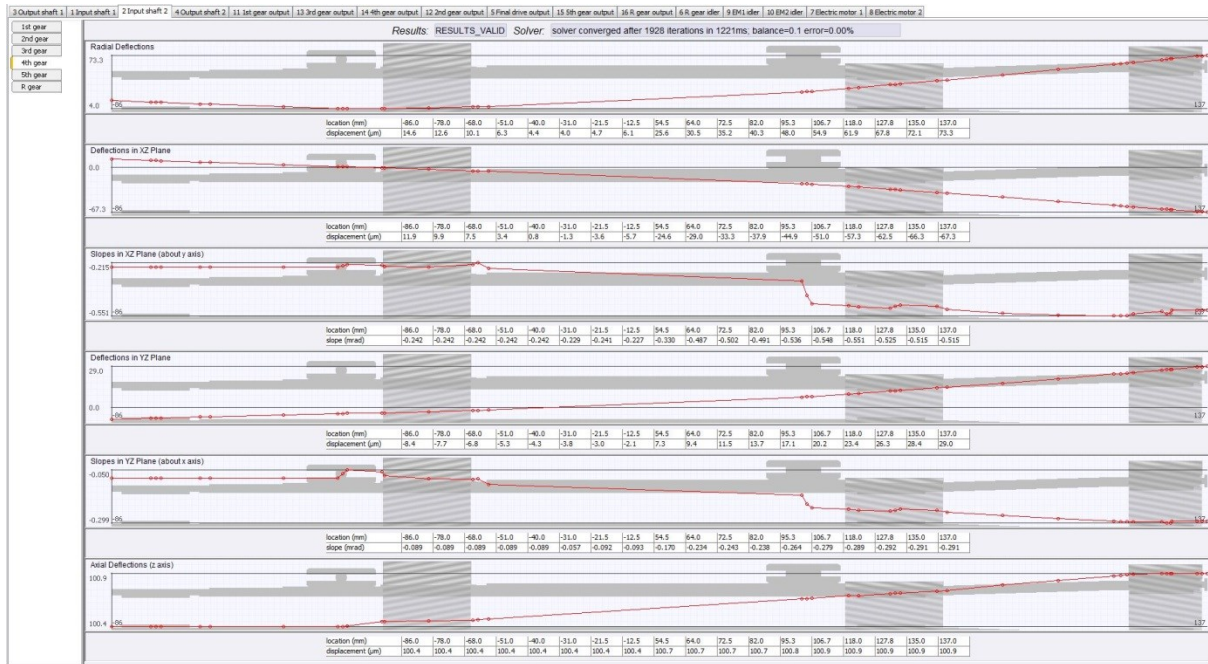

Figure 23: Input shaft 2 deflections in 4th gear

Maximum radial deflection of the input shaft 2 in 4<sup>th</sup> gear reached 73.3 μm.

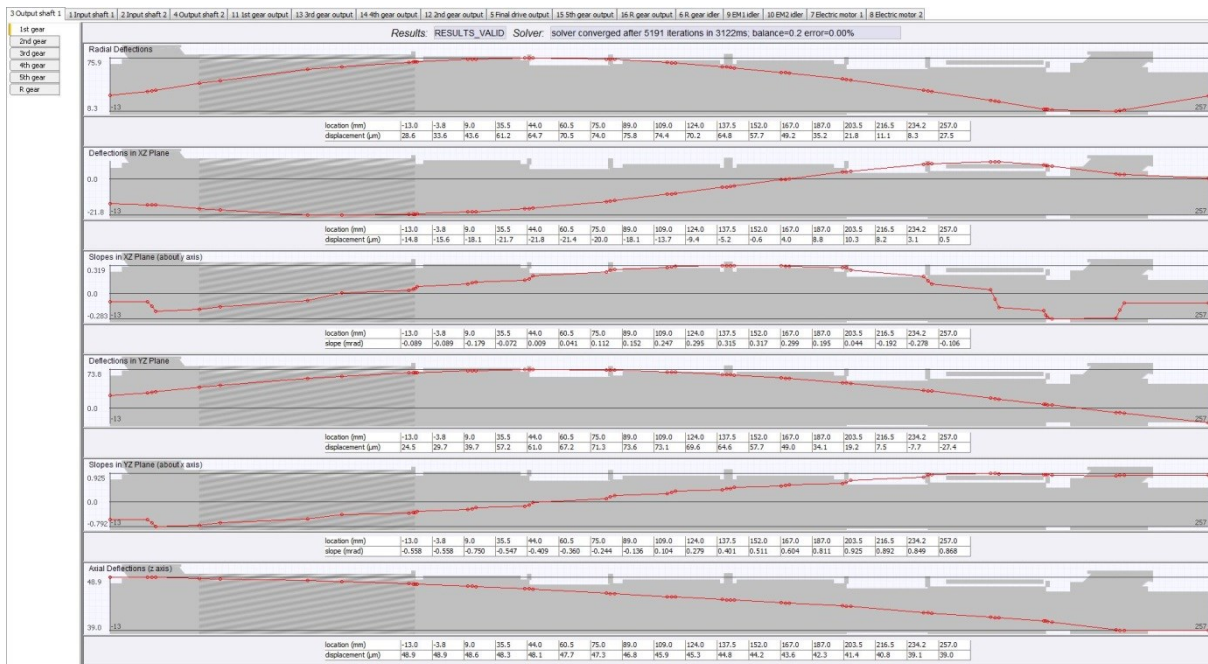
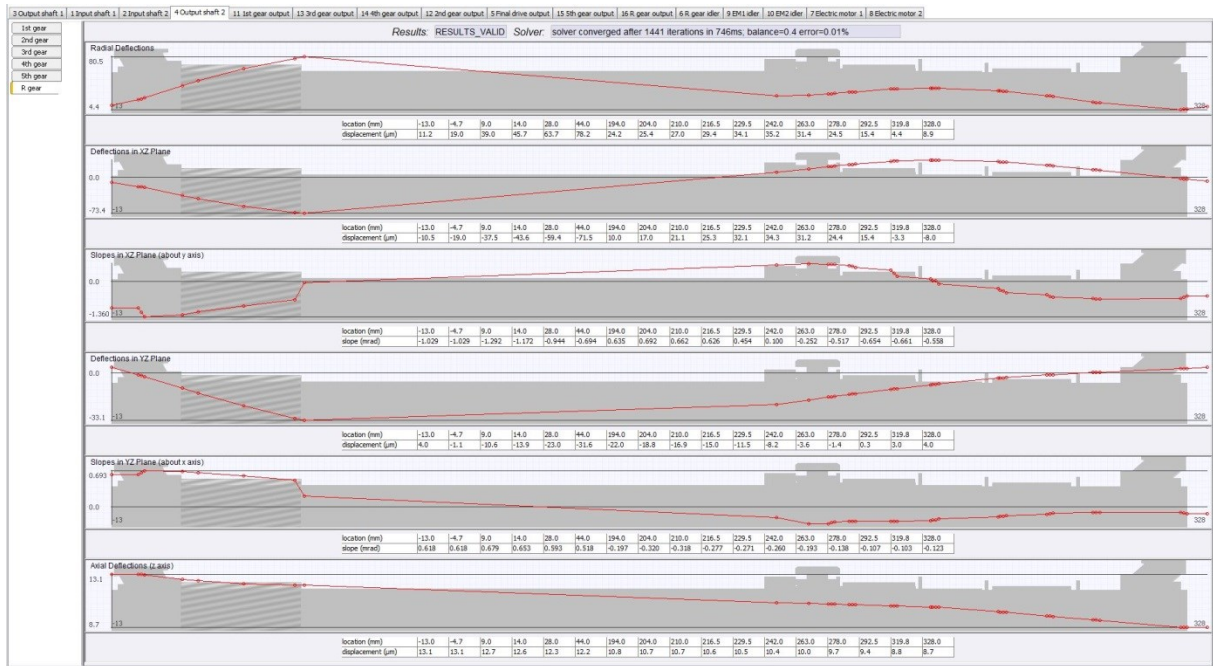

Figure 24: Output shaft 1 deflections in 1st gear

Maximum radial deflection of the output shaft 1 in 1<sup>st</sup> gear reached 75.9 μm.



**Figure 25: Output shaft 2 deflections in R gear**

Maximum radial deflection of the output shaft 2 in reverse gear reached 80.5 µm.



# 5 NEDC Simulation

---

To evaluate the gearbox design proposed in this thesis, mathematical models of reference vehicle drivelines were created. These models were used to simulate undertaking a standard driving cycle to calculate approximate difference in fuel consumption between the reference vehicle fitted with the internal combustion engine only and with the proposed hybrid driveline, which enabled to assess the relevance of the submitted design.

## 5.1 NEDC Characteristics

The New European Driving Cycle (NEDC) is a driving cycle defined in UNECE R101 for measuring fuel consumption and corresponding CO<sub>2</sub> emissions and UNECE R83 for measuring emissions of pollutants of production passenger cars [10][11]. It consists of four consecutive urban driving cycles (ECE-15) and one extra-urban driving cycle (EUDC).

There are differences for vehicles equipped with a manual and an automatic gearbox. With respect to the proposed design, the cycle with a manual transmission will be described and used.

### 5.1.1 Urban Driving Cycle

In the ECE-15 urban driving cycle, the vehicle simulates driving about in a city. The maximum speed reaches 50 km/h. The car performs the following procedure:

- 1) At first, the engine of the vehicle is started. The car pauses for 11 seconds. It spends 6 s in neutral with the clutch engaged and 5 s in the 1<sup>st</sup> gear with the clutch disengaged. The vehicle accelerates to 15 km/h in 4 s and then holds constant speed for another 8 s. It brakes to a halt in 5 s (with the clutch disengaged for the last 3 seconds). It remains stationary for 21 s of which it spends 16 seconds in neutral and the 5 s in the 1<sup>st</sup> gear.
- 2) At 49 seconds, the vehicle accelerates to 32 km/h in 12 s, the first 5 s of this period are spent in 1<sup>st</sup> gear, and then the vehicle shifts up in 2 s and spends the next 5 s in 2<sup>nd</sup> gear. The car drives at constant speed for 24 s and then brakes to a full stop in

11 s, with the clutch disengaged for the last 3 seconds. The vehicle remains stationary for another 21 s (16 s in neutral, 5 s in the 1<sup>st</sup> gear).

- 3) At 117 s, the vehicle accelerates to 50 km/h in 26 s (5s in 1<sup>st</sup> gear, 2 s for upshift, 9 s in 2<sup>nd</sup> gear, 2 s for upshift and 8 s in 3<sup>rd</sup> gear), then cruises for 12 s, slows down to 35 km/h in 8 s, holds constant speed for 13 s and then stops in 12 s (2 s for downshifting from 3<sup>rd</sup> to 2<sup>nd</sup>, 7 s in 2<sup>nd</sup> gear and the last 3 s with the clutch disengaged). The vehicle then stands still for 7 s in neutral with the clutch disengaged.

The ECE-15 cycle takes the total of 195 s and is repeated four times. The total duration is therefore 780 s across which a theoretical distance of 3976.1 m is covered at an average speed of 18.35 km/h.

## 5.1.2 Extra-Urban Driving Cycle

The extra-urban driving cycle is designed to simulate driving conditions outside a city. It is characterized by higher speeds and more aggressive driving. The top speed reaches 120 km/h. The driving procedure is as follows:

- 1) The vehicle stands still for 20 seconds in 1<sup>st</sup> gear with the clutch disengaged. After that, it accelerates to 70 km/h in 41 s (5 s in 1<sup>st</sup>, 9 s in 2<sup>nd</sup>, 8 s in 3<sup>rd</sup> and 13 s in 4<sup>th</sup> gear with 2 seconds for every gear change), it holds this speed for 50 s (in 5<sup>th</sup> gear) and slows down to 50 km/h in 8 s (4s in 5<sup>th</sup>, 4 s in 4<sup>th</sup>).
- 2) The vehicle cruises for 69 s and then accelerates to 70 km/h in 13 s. It holds this speed for 50 s (in 5<sup>th</sup> gear) and accelerates to 100 km/h in 35 s, where it remains for 30 s (in 5<sup>th</sup> or 6<sup>th</sup> gear).
- 3) At the end, the vehicle accelerates to 120 km/h in 20 s, cruises for 10 s, then brakes to a full stop in 34 s (in the 5<sup>th</sup> or 6<sup>th</sup> gear, the clutch disengaged for the last 10 s) and remains stationary at idle engine speed for 20 s (in neutral).

The extra-urban driving cycle takes 400 s. A theoretical distance of 6956 m is covered at an average speed of 62.6 km/h.

### 5.1.3 Combined NEDC

With four urban and one extra-urban driving cycles combined, the vehicle covers a theoretical distance of 11023 metres. The test takes 1180 s in total, the average speed reaches 33.6 km/h. The NEDC is sometimes quoted at 1220 s including the initial 40 s during which the car is stationary with its combustion engine off.

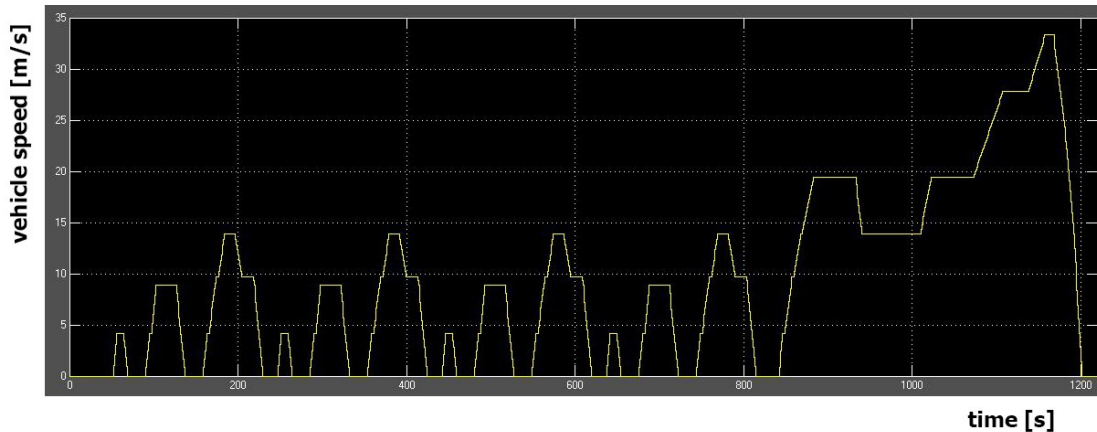

**Figure 26: Vehicle speed during the NEDC cycle**

## 5.2 QSS Toolbox

To create the mathematical model of the vehicle and perform the NEDC simulation, the Matlab R2012b software with Simulink extension was used. The vehicle diagram consists of various blocks and functions. Some were taken from the Matlab Simulink library, others were newly created or customized. However, for the main vehicle blocks, the QSS Toolbox was used.

The QSS Toolbox (QuasiStatic Simulation Toolbox) is a set of blocks developed at the Institute of Dynamic Systems and Control at the ETH University in Zurich, Switzerland [7]. The block functions were customized according to the parameters of the reference vehicle and driveline developed in this thesis. Used blocks are described on the following pages.

## 5.3 Vehicle Models

### 5.3.1 Ford Fiesta

The complexity of vehicle driving simulation and lack of detailed data leads to simplifications and approximations in various areas of the mathematical model. To get a reference, a model of Ford Fiesta with the 1.25 DuraTec engine was created. At its end, fuel consumption and CO<sub>2</sub> emission figures are obtained and compared with available factory data.

The model is shown in the following figure:

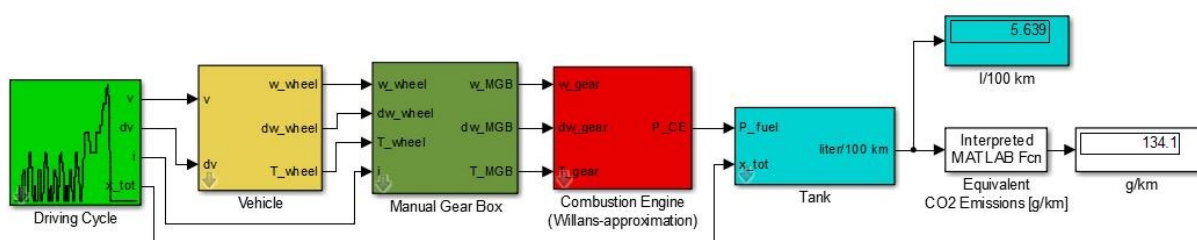

**Figure 27: Ford Fiesta 1.25 DuraTec simulation model**

#### 5.3.1.1 Driving Cycle Block

The Driving Cycle block loads the cycle data such as time, speed, acceleration and gear number from the data file of the selected driving cycle and makes them available on the block output.

Origin: QSS Toolbox

Outputs:

$v$	vehicle speed [ $m \cdot s^{-1}$ ]
$dv$	vehicle acceleration [ $m \cdot s^{-2}$ ]
$i$	selected gear ratio [-]
$x_{tot}$	total distance [ $m$ ]

Parameters to select:

Driving cycle: NEDC manual

### 5.3.1.2 Vehicle Block

The Vehicle block computes the power required from the vehicle.

Origin: QSS Toolbox

Inputs:

$v$	vehicle speed [ $m \cdot s^{-1}$ ]
$dv$	vehicle acceleration [ $m \cdot s^{-2}$ ]

Outputs:

$w_{wheel}$	speed of the wheel [ $rad \cdot s^{-1}$ ]
$dw_{wheel}$	acceleration of the wheel [ $rad \cdot s^{-2}$ ]
$T_{wheel}$	torque on the wheel [ $Nm$ ]

Parameters to select:

Total mass of the vehicle:	1128 kg [3]
Rotating mass:	5% (approximated)
Vehicle cross section:	2.08 m <sup>2</sup> [3]
Wheel diameter:	0.581 m [3]
Drag coefficient:	0.33 [3]
Rolling friction coefficient:	0.011 [1]

### 5.3.1.3 Manual Gear Box Block

The Manual Gear Box block simulates a gearbox with multiple selectable gear steps.

Origin: QSS Toolbox

Inputs:

$w_{wheel}$	speed of the wheel [ $rad \cdot s^{-1}$ ]
$dw_{wheel}$	acceleration of the wheel [ $rad \cdot s^{-2}$ ]
$T_{wheel}$	torque on the wheel [ $Nm$ ]
$i$	selected gear [-]

Outputs:

$w_{MGB}$	speed of the flywheel [ $rad \cdot s^{-1}$ ]
$dw_{MGB}$	acceleration of the flywheel [ $rad \cdot s^{-2}$ ]
$T_{MGB}$	torque on the flywheel [ $Nm$ ]

Parameters to select:

1 <sup>st</sup> gear ratio:	14.55 [3]
2 <sup>nd</sup> gear ratio:	7.82 [3]
3 <sup>rd</sup> gear ratio:	5.20 [3]
4 <sup>th</sup> gear ratio:	3.86 [3]
5 <sup>th</sup> gear ratio:	3.07 [3]
Differential gear:	1 (final drive ratio contained in individual ratios)
Efficiency:	0.96
Idling losses:	300 W (pre-set value)
Minimum wheel speed beyond which losses are generated:	
	1 $rad \cdot s^{-1}$ (pre-set value)

**5.3.1.4 Combustion Engine Block**

The Combustion Engine block simulates the behaviour of a combustion engine. The block is based on the Willans approximation with friction part based on the ETH model [source].

Origin: QSS Toolbox

Inputs:

$w_{gear}$	speed of the flywheel [ $rad \cdot s^{-1}$ ]
$dw_{gear}$	acceleration of the flywheel [ $rad \cdot s^{-2}$ ]
$T_{gear}$	torque on the flywheel [ $Nm$ ]

Outputs:  $P_{CE}$  power produced by the combustion engine [ $W$ ]

Parameters to select:

Engine type:	Otto
Displacement:	1.242 l [3]
Engine inertia:	0.09 $kg \cdot m^2$ (approx. from the pre-set value)
Stroke:	71.9 mm [3]

Bore diameter: 76.5 mm [3]

Engine speed at idle: 104.72  $rad \cdot s^{-1}$  [3]

Engine power at idle: 8000 W [3]

Power required by auxiliaries: 300 W (pre-set value)

1. Willans parameter – Engine internal thermodynamic efficiency:

0.35 (estimated)

2. Willans parameter – Maximum boost ratio:

1 (estimated)

3. Willans parameter – Gas exchange losses:

0.5 bar (pre-set value)

Enable fuel cutoff: yes

Engine torque at fuel cutoff: 5 Nm (pre-set value)

Power at fuel cutoff: 0 W (pre-set value)

### 5.3.1.5 Tank Block

The Tank block integrates the power (the fuel mass flow) required by the combustion engine and calculates the fuel consumption in liters per 100 km.

Origin: QSS Toolbox

Inputs:  $P_{fuel}$  power (fuel mass flow) required [W]

$x_{tot}$  total distance [m]

Outputs:  $V$  fuel consumption [l/100 km]

Parameters to select:

Fuel: gasoline

Include cold start losses: yes

### 5.3.1.6 Equivalent CO<sub>2</sub> Emissions Block

The Equivalent CO<sub>2</sub> Emissions block recalculates the fuel consumption to CO<sub>2</sub> emissions in g/km. It assumes emission of 2.379 kg of CO<sub>2</sub> per 1 liter of petrol [8].

Origin: self-created

Inputs:  $V$  fuel consumption [l/100 km]

Outputs:  $m_{CO_2}$  CO<sub>2</sub> emissions [g/km]

### 5.3.1.7 Results

As can be seen in Fig.15, the resulting fuel consumption of the model of Ford Fiesta 1.25 DuraTec is 5.98 l/100 km. The factory figures claim fuel consumption of 5.2 l/100 km. This discrepancy indicates the error made by simplifications and estimations made during creation of the Simulink model. This needs to be taken into consideration when assessing the results obtained for the reference vehicle.

## 5.3.2 Non-Hybrid Reference Vehicle

A model of the reference vehicle (described in 2.2) only fitted with the Ford 1.25 DuraTec engine was created to assess its fuel consumption and CO<sub>2</sub> emissions and prepare a baseline for evaluation of the hybrid concept elaborated in this thesis.

The model is shown in the following figure:

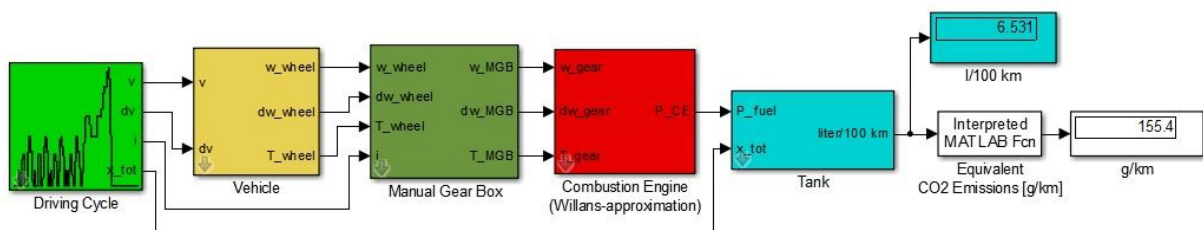

**Figure 28: Simulink model of the reference vehicle fitted with the ICE only**

The Simulink model uses the same blocks as the Ford Fiesta model. The blocks are therefore not going to be described again, only the overview of selected parameters is listed.



### 5.3.2.1 Driving Cycle Block

No changes were made compared to the Ford Fiesta model. For all the details, see 5.3.1.1.

### 5.3.2.2 Vehicle Block

For detailed description, see 5.3.1.2.

#### Parameters to select:

Total mass of the vehicle:	1163 <i>kg</i>
Rotating mass:	4% (approximated)
Vehicle cross section:	2.23 <i>m</i> <sup>2</sup>
Wheel diameter:	0.586 <i>m</i>
Drag coefficient:	0.29
Rolling friction coefficient:	0.011

### 5.3.2.3 Manual Gear Box Block

For detailed description, see 5.3.1.3.

#### Parameters to select:

1 <sup>st</sup> gear ratio:	13.962
2 <sup>nd</sup> gear ratio:	9.350
3 <sup>rd</sup> gear ratio:	6.600
4 <sup>th</sup> gear ratio:	4.756
5 <sup>th</sup> gear ratio:	3.300
Differential gear:	1 (final drive ratio contained in individual ratios)
Efficiency:	0.96
Idling losses:	300 <i>W</i> (pre-set value)
Minimum wheel speed beyond which losses are generated:	1 <i>rad · s</i> <sup>-1</sup> (pre-set value)

#### **5.3.2.4 Combustion Engine Block**

No changes were made compared to the Ford Fiesta model. For all the details, see 5.3.1.4.

#### **5.3.2.5 Tank Block**

No changes were made compared to the Ford Fiesta model. For all the details, see 5.3.1.5.

#### **5.3.2.6 Equivalent CO<sub>2</sub> Emissions Block**

No changes were made compared to the Ford Fiesta model. For all the details, see 5.3.1.6.

#### **5.3.2.7 Results**

The reference vehicle equipped only with the Ford 1.25 DuraTec engine. Electric motors and the battery pack are not counted. Its combined fuel consumption in the NEDC cycle is 6.5 l/100 km and it produces 155.4 g of CO<sub>2</sub> per km.

The difference in the fuel economy and CO<sub>2</sub> emissions is given by higher curb weight and frontal area of the reference vehicle and by different gear ratios of the gearbox. However, the main interest focuses on the difference in results of this model and the hybrid vehicle model that follows.

### 5.3.3 Hybrid Reference Vehicle

The basic driveline remains unchanged in comparison with the previous Simulink models. However, this model is also equipped with electric motors and is more complex due to incorporating a hybridization strategy.

The model is shown in the following figure:

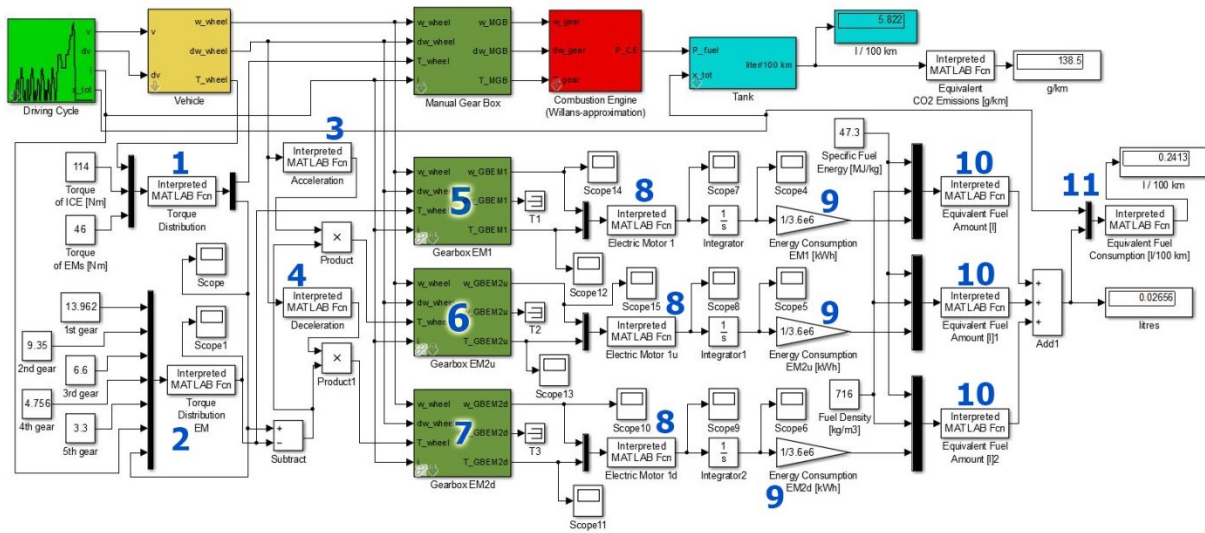

**Figure 29: Simulink model of the reference vehicle with ICE and two electric motors**

Blocks already used in the previous Simulink model remain unchanged. For their description, see 5.3.2. The only modifications were applied to the Vehicle block because with incorporating the hybrid system, its weight was raised.

Newly added blocks are labelled in the Fig.29 with numbers to help with their distinguishing and description.

#### 5.3.3.1 Vehicle Block

For detailed description, see 5.3.1.2.

Parameters to select:

- Total mass of the vehicle: 1413 kg
- Rotating mass: 4% (approximated)
- Vehicle cross section: 2.23 m<sup>2</sup>
- Wheel diameter: 0.586 m

Drag coefficient: 0.29

Rolling friction coefficient: 0.011

### 5.3.3.2 Torque Distribution Block (1)

For the vehicle equipped with the internal combustion engine and two electric motors, a simple hybridization strategy was used. At any given moment, the torque demand of the vehicle is distributed between the ICE and the pair of electric motors according to the ratio of their maximum torques.

Origin: self-created

Inputs:  $T_{wheel}$  torque on the wheel [ $Nm$ ]

$T_{ICE}$  maximum torque of the combustion engine [ $Nm$ ]

$T_{EMS}$  combined maximum torque of electric motors [ $Nm$ ]

Outputs:  $T_1$  torque component demanded from the ICE [ $Nm$ ]

$T_2$  torque component demanded from electric motors [ $Nm$ ]

### 5.3.3.3 Torque Distribution EM Block (2)

The part of the torque demanded from electric motors is distributed between them according to their respective gear ratios at any given moment. One electric motor always works on the same gear as the combustion engine, the other motor uses a different gear (see 3.2.2). In reality, as the combustion engine swaps the input shafts of the gearbox depending on the selected gear, the electric motors swap their roles of being the one working on the same gear as the combustion engine. In this Simulink model, the situation is different in that one electric motor is always working with the combustion engine while the other EM is always working on a different gear. This fact, however, makes no difference to the results because two identical electric motors are used.

Origin: self-created

Inputs:  $i_{1-5}$  ratio of 1<sup>st</sup> – 5<sup>th</sup> speed [-]

$i$  selected gear [-]

$T_2$  torque component demanded from electric motors [ $Nm$ ]

<u>Outputs:</u>	$T_A$	torque demanded from the EM working with ICE [ $Nm$ ]
	$T_B$	torque demanded from the other electric motor [ $Nm$ ]

### 5.3.3.4 Acceleration Block (3)

As different shifting strategy is used for cases when the vehicle accelerates/cruises or decelerates, the second electric motor was duplicated (one EM block for acceleration/cruising, one for decelerating). Each of these electric motor blocks has its own gearbox block which respects the difference in the shifting strategy for these two cases.

The Acceleration block uses simple “if” logic to determine whether the vehicle is accelerating/cruising or decelerating at any given moment. When the vehicle is accelerating or cruising, it sends out value of “1” to make no difference to the torque demanded from the “up” electric motor. When the vehicle is decelerating, this block sends out value of “0” to stop the torque demand from the “up” electric motor.

<u>Origin:</u>	self-created	
<u>Inputs:</u>	$dw_{wheel}$	acceleration of the wheel [ $rad \cdot s^{-2}$ ]
<u>Outputs:</u>	1	in case $dw_{wheel} \geq 0$
	0	in case $dw_{wheel} < 0$

### 5.3.3.5 Deceleration Block (4)

The Deceleration block uses the same “if” logic as the Acceleration block, only inversely. Its output value multiplies the torque demanded from the “down” electric motor. Hence, when the vehicle is accelerating or cruising, the torque demand from the “down” motor is disconnected. When the vehicle is decelerating, the torque demand from the “down” motor remains unchanged.

<u>Origin:</u>	self-created	
<u>Inputs:</u>	$dw_{wheel}$	acceleration of the wheel [ $rad \cdot s^{-2}$ ]
<u>Outputs:</u>	0	in case $dw_{wheel} \geq 0$
	1	in case $dw_{wheel} < 0$

### 5.3.3.6 Gearbox EM1 Block (5)

The Gearbox EM1 block is the mechanical gear box block from the QSS Toolbox. It simulates the multiplication of the torque transmitted from the electric motor that works on the same gear as the combustion engine. For detailed description, see 5.3.1.3.

#### Parameters to select:

1 <sup>st</sup> gear ratio:	$13.962 \cdot 1.28$
2 <sup>nd</sup> gear ratio:	$9.350 \cdot 1.28$
3 <sup>rd</sup> gear ratio:	$6.600 \cdot 1.28$
4 <sup>th</sup> gear ratio:	$4.756 \cdot 1.28$
5 <sup>th</sup> gear ratio:	$3.300 \cdot 1.28$
Differential gear:	1 (final drive ratio contained in individual ratios)
Efficiency:	0.92

### 5.3.3.7 Gearbox EM2u Block (6)

The Gearbox EM2u block simulates the multiplication of the torque demanded from the electric motor working on a different gear than the combustion engine and the first electric motor while the vehicle is accelerating or cruising. It respects the proposed shifting strategy (see 3.2.2). The only difference from the Gearbox EM1 block is therefore in the order of the gear ratios. For detailed description, see 5.3.1.3.

Same value appears in the 3<sup>rd</sup> and 5<sup>th</sup> gear ratio. The reason is that when 3<sup>rd</sup> speed is selected, the 4<sup>th</sup> gear is already pre-shifted and transmits torque from the second electric motor. When the 5<sup>th</sup> gear is selected, it is again the 4<sup>th</sup> gear that is pre-shifted and transmits torque from the second electric motor.

#### Parameters to select:

1 <sup>st</sup> gear ratio:	$9.350 \cdot 1.28$
2 <sup>nd</sup> gear ratio:	$6.600 \cdot 1.28$
3 <sup>rd</sup> gear ratio:	$4.756 \cdot 1.28$
4 <sup>th</sup> gear ratio:	$3.300 \cdot 1.28$

5 <sup>th</sup> gear ratio:	$4.756 \cdot 1.28$
Differential gear:	1 (final drive ratio contained in individual ratios)
Efficiency:	0.92

### 5.3.3.8 Gearbox EM2d Block (7)

The Gearbox EM2d block works similarly as the Gearbox EM2u block, only it follows the shifting strategy for the case of the vehicle decelerating. For detailed description, see 5.3.1.3.

As with the Gearbox EM2u block, same value appears twice – in 1<sup>st</sup> and 3<sup>rd</sup> gear. The reason remains the same. When the 3<sup>rd</sup> speed is shifted, the 2<sup>nd</sup> gear is pre-shifted and transmits torque from the second electric motor. When the 1<sup>st</sup> speed is shifted, the same occurs.

#### Parameters to select:

1 <sup>st</sup> gear ratio:	$9.350 \cdot 1.28$
2 <sup>nd</sup> gear ratio:	$13.962 \cdot 1.28$
3 <sup>rd</sup> gear ratio:	$9.350 \cdot 1.28$
4 <sup>th</sup> gear ratio:	$6.600 \cdot 1.28$
5 <sup>th</sup> gear ratio:	$4.756 \cdot 1.28$
Differential gear:	1 (final drive ratio contained in individual ratios)
Efficiency:	0.92

### 5.3.3.9 Electric Motor Block (8)

The Electric Motor Block works with a simplified efficiency map of a permanent magnet synchronous motor to convert the torque and rotational speed demands of the gearbox into power produced by the electric motor.

<u>Origin:</u>	self-created	
<u>Inputs:</u>	$w_{GBEM}$	speed of the motor output shaft [ $rad \cdot s^{-1}$ ]
	$T_{GBEM}$	torque produced by the electric motor [ $Nm$ ]

Outputs:  $P_{EM}$  power produced by the electric motor [W]

### 5.3.3.10 Energy Consumption Block (9)

The Energy Consumption block uses integration of the power produced by the electric motor and converts the resulting energy to kWh. On the output, it gives out the amount of energy needed to go through the NEDC cycle.

Origin: self-created

Inputs:  $Q$  electric energy consumption [J]

Outputs:  $Q$  electric energy consumption [kWh]

### 5.3.3.11 Equivalent Fuel Amount Block (10)

The Equivalent Fuel Amount block recalculates the energy consumption from kWh to litres of petrol, considering specific fuel energy of  $47.3 \text{ MJ} \cdot \text{kg}^{-1}$  and fuel density of  $716 \text{ kg} \cdot \text{m}^{-3}$  [9]. The recalculation serves to give a better idea of energy consumption during creation of the simulation model.

Origin: self-created

Inputs:  $Q$  energy consumption [kWh]

Outputs:  $V$  equivalent amount of fuel [L]

### 5.3.3.12 Equivalent Fuel Consumption Block (11)

The Equivalent Fuel Consumption block combines the equivalent amount of fuel theoretically consumed by the electric motors and the total distance travelled during the NEDC cycle to give a theoretical equivalent fuel consumption of the electric part of the driveline.

Origin: self-created

Inputs:  $x_{tot}$  total distance [m]

$V$  equivalent amount of fuel [L]

Outputs:  $fc$  equivalent fuel consumption [l/100 km]



### 5.3.3.13 Results

The reference vehicle equipped with the Ford 1.25 DuraTec engine and two Parker SKW091-092LAM motors using the hybridization strategy mentioned in 5.3.3.2 reaches fuel consumption of 5.82 l/100 km and produces 138.5 g of CO<sub>2</sub> per km. That is 0.71 l/100 km and 16.9 g/km less than in case of only using the combustion engine, which means the proposed concept of the driveline works as it should and brings savings in fuel economy and CO<sub>2</sub> emissions.

The hybridization strategy is not elaborated in any further details in this thesis. Possibilities of exploiting the proposed concept better and gaining even more than is shown by presented results are therefore not explored. To conclude this chapter however, a diagram depicting the overall energy balance of the electric part of the driveline is shown. It indicates how much energy the electric motors need to help reach the presented results, but also reveals areas of potential energy recovery under braking in those parts of the diagram where the amount of needed energy falls down.

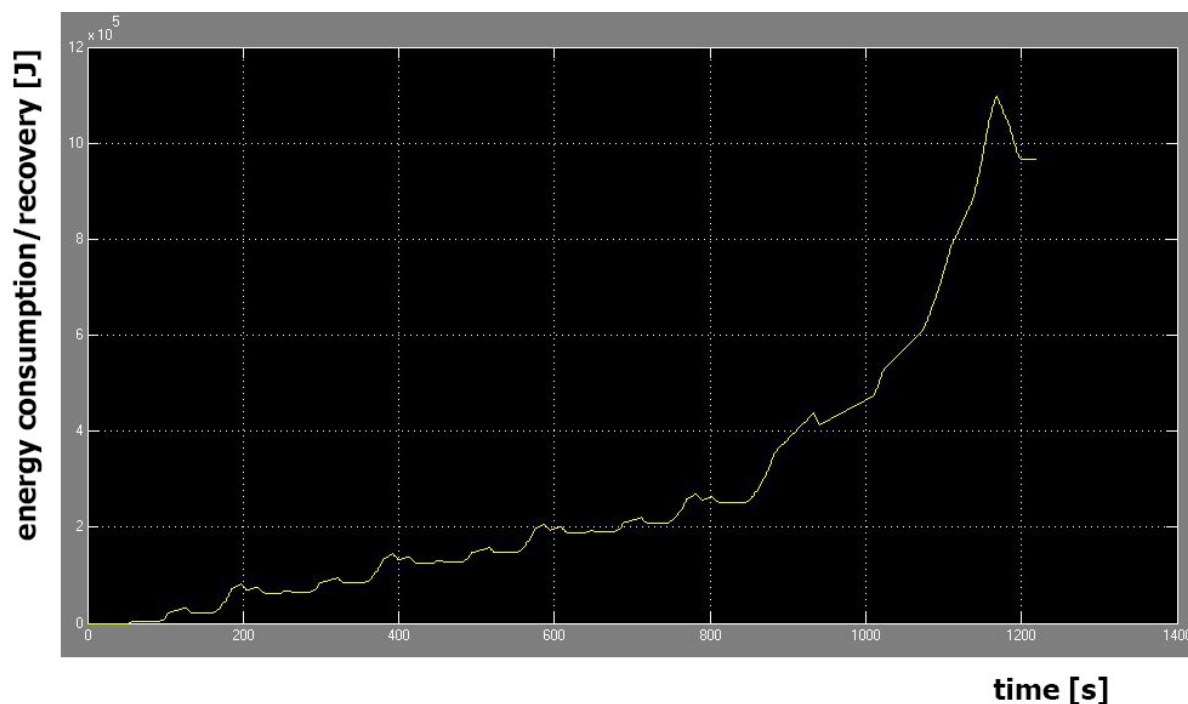

Figure 30: Energy balance of the electric part of the driveline

## 6 Conclusion

---

In this diploma thesis, a concept of a hybrid vehicle using an internal combustion engine and two electric motors mounted to the double-clutch transmission was proposed and elaborated. Its design was based around a B-segment car. A reference vehicle combining average and ideal parameters of production vehicles available in this category was created for the purpose.

During the design phase, a number of decisions was made with respect to the vehicle size and use. One was to follow a transmission concept with two output shafts to enable using certain gear wheels on input shafts for more gear steps and thus make the gearbox shorter to help it better fit in the limited compartment of a B-segment car, although this intention was challenged by various contradictory demands such as overall packaging (with the need to fit two electric motors), obtaining correct gear ratios or strength tested in the duty cycle simulation.

Despite the fact that the majority of the B-segment production vehicles use 6-speed (some even 7-speed) gearboxes, the use of extra torque from electric motors and the calculated gear spread allowed for the use of only 5-speed transmission which further helped the overall packaging.

The following load cycle simulation proved the strength and durability of the proposed design concept over the course of a duty cycle indicated in the thesis.

At the end, a mathematical model of the proposed concept was developed and tested over a unified NEDC driving cycle. Fuel economy and CO<sub>2</sub> emissions figures were compared to a model only using the internal combustion engine. Results showed that despite fitting the vehicle with a hybrid system adds extra weight but still helps to lower the fuel consumption and emissions of carbon dioxide.

The proposed design might even have reached better results with a more suitable and further elaborated hybridization strategy. However, developing one was not the focus of this thesis. The conclusion is the proposed concept does bring anticipated results.

## 7 List of Figures

---

Figure 1: Study layout .....	9
Figure 2: Ford 1.25 DuraTec performance characteristics [3] .....	12
Figure 3: Parker SKW091-092-LAM performance characteristics [4].....	13
Figure 4: Dependence of coefficient of rotational inertia on gear ratio [1] .....	17
Figure 5: An accelerating car on inclined road [6].....	18
Figure 6: Acceleration data of Ford Fiesta 1.25 DuraTec with extrapolation [3].....	22
Figure 7: Proposed gear steps.....	25
Figure 8: Layout of the double-clutch gearbox with two electric motors .....	28
Figure 9: Vehicle driving in the 1st gear .....	30
Figure 10: Vehicle driving in the 2nd gear .....	30
Figure 11: Vehicle driving in the 3rd gear .....	31
Figure 12: Vehicle driving in the 4th gear .....	31
Figure 13: Vehicle driving in the 5th gear .....	32
Figure 14: Vehicle driving in the reverse gear .....	32
Figure 15: Kinematic path from ICE to EM2 .....	39
Figure 16: Traction diagram of the proposed gearbox .....	40
Figure 17: 3D concept overview .....	41
Figure 18: Cross section through input and output shafts .....	42
Figure 19: Positioning of the gearbox in relation to the vehicle orientation.....	43
Figure 20: Proportional usage of gears .....	44
Figure 21: SABR model of proposed gearbox concept.....	45
Figure 22: Input shaft 1 deflections in R gear .....	46
Figure 23: Input shaft 2 deflections in 4th gear.....	47
Figure 24: Output shaft 1 deflections in 1st gear .....	47
Figure 25: Output shaft 2 deflections in R gear .....	48
Figure 26: Vehicle speed during the NEDC cycle .....	51
Figure 27: Ford Fiesta 1.25 DuraTec simulation model .....	52
Figure 28: Simulink model of the reference vehicle fitted with the ICE only .....	56
Figure 29: Simulink model of the reference vehicle with ICE and two electric motors.....	59
Figure 30: Energy balance of the electric part of the driveline .....	65

## 8 List of Tables

---

Table 1: Coefficients of rolling resistance [1].....	16
Table 2: Coefficients of adhesion [1].....	19
Table 3: Bearing life.....	45

## 9 List of Annexes

---

1. Table including benchmark data of B-segment vehicles
2. Cross-section view of the gearbox
3. Deflections of input shaft 1 in R gear
4. Deflections of input shaft 2 in 4<sup>th</sup> gear
5. Deflections of output shaft 1 in 1<sup>st</sup> gear
6. Deflections of output shaft 2 in R gear

# 10 Used Literature

---

- [1] NAUNHEIMER, Harald. *Automotive transmissions: fundamentals, selection, design, and application*. 2nd ed. Berlin: Springer, c2011. ISBN 978-3-642-16213-8.
- [2] MORAVEC, Vladimír. *Mechanické a hydraulické převody. Mechanické převody*. Skripta VŠB-TU Ostrava, 2000
- [3] 2015 Ford Fiesta 1.25 (82) Trend engine Horsepower / Torque Curve. *Automobile Catalog* [online]. 2015 [cit. 2017-01-12]. Available from: [http://www.automobile-catalog.com/curve/2015/1817120/ford\\_fiesta\\_1\\_25\\_82\\_trend.html](http://www.automobile-catalog.com/curve/2015/1817120/ford_fiesta_1_25_82_trend.html)
- [4] SKW Speed and Torque Curves. *Parker* [online]. [cit. 2017-01-12]. Available from: [http://www.parker.com/literature/Electromechanical%20Europe/Parvex/SKW\\_SpeedTorque\\_Curves.pdf](http://www.parker.com/literature/Electromechanical%20Europe/Parvex/SKW_SpeedTorque_Curves.pdf)
- [5] 10 Most Unique Roads In The World. *10 Most Today* [online]. 2014 [cit. 2017-01-12]. Available from: <http://10mosttoday.com/10-most-unique-roads-in-the-world/>
- [6] REZA N. JAZAR. *Vehicle dynamics: theory and applications*. Corr., 2. pr. New York: Springer, 2008. ISBN 9780387742434.
- [7] QSS Toolbox. In: *ETH Zürich* [online]. 2017 [cit. 2017-01-12]. Available from: [https://www.ethz.ch/content/dam/ethz/special-interest/mavt/dynamic-systems-n-control/idsc-dam/Research\\_Onder/Downloads/qss.zip](https://www.ethz.ch/content/dam/ethz/special-interest/mavt/dynamic-systems-n-control/idsc-dam/Research_Onder/Downloads/qss.zip)
- [8] Calculate CO2 emissions from fossil fuel combustion. *Green Clean Guide* [online]. 2011 [cit. 2017-01-12]. Available from: <http://greencleanguide.com/calculate-co2-emissions-from-fossil-fuel-combustion/>
- [9] *Specific Energy and Energy Density of Fuels* [online]. [cit. 2017-01-13]. Available from: <https://neutrium.net/properties/specific-energy-and-energy-density-of-fuels/>
- [10] *Agreement concerning the adoption of uniform technical prescriptions for wheeled vehicles, equipment and parts* [online]. [cit. 2017-01-13]. Available from: <http://www.unece.org/trans/main/wp29/wp29regs101-120.html>
- [11] *Agreement concerning the adoption of uniform conditions of approval and reciprocal recognition of approval for motor vehicle equipment and parts* [online]. [cit. 2017-01-13]. Available from: <http://www.unece.org/trans/main/wp29/wp29regs81-100.html>
- [12] Kia Rio – technické informace. In: *Kia* [online]. 2015 [cit. 2017-01-12]. Available from: <http://www.kia.com/cz/kampane/ceniky-a-katalogy/>
- [13] Technická specifikace 500L. In: *Fiat* [online]. 2015 [cit. 2017-01-12]. Available from: <http://www.fiat.cz/UserFiles/technika/500L%20CZ.PDF>

- [14] Swift. In: *Suzuki* [online]. 2016 [cit. 2017-01-12]. Available from:  
<http://www.suzuki.cz/auto/swift/cenik.pdf>
- [15] Ceník nová DS 3. In: *My Citroen* [online]. 2016 [cit. 2017-01-12]. Available from:  
[http://www.mycitroen.cz/Resources/Content/CZ/07\\_PDF\\_gallery/09\\_cenik\\_VP/Cenik\\_DS\\_3.pdf](http://www.mycitroen.cz/Resources/Content/CZ/07_PDF_gallery/09_cenik_VP/Cenik_DS_3.pdf)
- [16] Ceník Ibiza. In: *Seat* [online]. 2015 [cit. 2017-01-12]. Available from:  
[http://www.seat.cz/media/Kwc\\_Basic\\_DownloadTag\\_Component/670-3952-list-3112-link-linkTag-child/default/227e9ce7/1482306470/seat-cenik-ibiza-v08-nahled-12-16.pdf](http://www.seat.cz/media/Kwc_Basic_DownloadTag_Component/670-3952-list-3112-link-linkTag-child/default/227e9ce7/1482306470/seat-cenik-ibiza-v08-nahled-12-16.pdf)
- [17] Katalog Fiesta. In: *Ford* [online]. 2016 [cit. 2017-01-12]. Available from:  
<http://m.ford.cz/KatalogyKeStazeni>
- [18] Brožura Clio. In: *Renault* [online]. 2016 [cit. 2017-01-12]. Available from:  
<https://www.cdn.renault.com/content/dam/Renault/CZ/pdf/brozura/clio-brozura.pdf>
- [19] Škoda Fabia a Fabia Combi. In: *Škoda Auto* [online]. 2016 [cit. 2017-01-12]. Available from:  
<http://www.skoda-auto.cz/SiteCollectionDocuments/skoda-auto/ke-stazeni/fabia-katalog.pdf>
- [20] Hyundai i20. In: *Hyundai* [online]. 2016 [cit. 2017-01-12]. Available from:  
<https://www.hyundai.cz/files/download/model/i20-2014/hyundai-i20-tech-specs-2016-290316.pdf>
- [21] Jazz. In: *Honda* [online]. 2016 [cit. 2017-01-12]. Available from:  
[https://secure.honda.cz/content/dam/local/czech-republic/brochures/cars/CZ%20Jazz%20katalog\\_2016.pdf](https://secure.honda.cz/content/dam/local/czech-republic/brochures/cars/CZ%20Jazz%20katalog_2016.pdf)
- [22] Mazda 2. In: *Mazda* [online]. 2015 [cit. 2017-01-12]. Available from:  
[https://www.mazda.cz/assets/czech/cars/brochures/ANM2/Mazda2\\_Brochure\\_CZ.pdf](https://www.mazda.cz/assets/czech/cars/brochures/ANM2/Mazda2_Brochure_CZ.pdf)
- [23] Nissan Micra. In: *Nissan* [online]. 2016 [cit. 2017-01-12]. Available from: [https://www.nissan-cdn.net/content/dam/Nissan/cz/brochures/Pricelists/NEW\\_MICRA\\_CZ.pdf](https://www.nissan-cdn.net/content/dam/Nissan/cz/brochures/Pricelists/NEW_MICRA_CZ.pdf)
- [24] Nový Nissan Note. In: *Nissan* [online]. 2016 [cit. 2017-01-12]. Available from:  
[https://www.nissan-cdn.net/content/dam/Nissan/cz/brochures/Pricelists/NEW\\_NOTE\\_CZ.pdf](https://www.nissan-cdn.net/content/dam/Nissan/cz/brochures/Pricelists/NEW_NOTE_CZ.pdf)
- [25] Peugeot 208. In: *Peugeot* [online]. 2016 [cit. 2017-01-12]. Available from:  
<http://peugeot.ecpaper.cz/osobni/208/208/Peugeot-208-cenik/data/Peugeot-208-cenik.pdf>
- [26] Polo. In: *Volkswagen* [online]. 2016 [cit. 2017-01-12]. Available from:  
<https://www.volkswagen.co.uk/assets/common/pdf/brochures/polo-gp-brochure.pdf>
- [27] Yaris. In: *Toyota* [online]. 2017 [cit. 2017-01-12]. Available from:  
[https://pdf.sites.toyota.cz/cenik\\_yaris.pdf](https://pdf.sites.toyota.cz/cenik_yaris.pdf)
- [28] A1. In: *Audi* [online]. 2015 [cit. 2017-01-12]. Available from:  
[http://www.audi.cz/media/Kwc\\_Basic\\_DownloadTag\\_Component/14221-85955-58982-85958-58984-85961-140091-downloadTag/default/ec800e09/1474276579/a1-a1sportback-katalog.pdf](http://www.audi.cz/media/Kwc_Basic_DownloadTag_Component/14221-85955-58982-85958-58984-85961-140091-downloadTag/default/ec800e09/1474276579/a1-a1sportback-katalog.pdf)
- [29] Alfa Romeo Mito. In: *Alfa Romeo* [online]. 2014 [cit. 2017-01-12]. Available from:  
[https://www.alfaromeo.com.au/vehicles/Mito-Buyers-Guide\\_v6-No-MSRP.pdf](https://www.alfaromeo.com.au/vehicles/Mito-Buyers-Guide_v6-No-MSRP.pdf)