

Czech Technical University in Prague
Faculty of Transportation Sciences

Josef Černý

**Service Board Design for a Traction Battery of
a Battery Electric Vehicle
(Master's thesis)**

2016



CZECH TECHNICAL UNIVERSITY IN PRAGUE

Faculty of Transportation Sciences

Dean's office

Konviktská 20, 110 00 Prague 1, Czech Republic

K620.....Department of Transport Telematics

MASTER'S THESIS ASSIGNMENT

(PROJECT, WORK OF ART)

Student's name and surname (including degrees):

Bc. Josef Černý

Code of study programme code and study field of the student:

N 3710 – IS – Intelligent Transport Systems

Theme title (in Czech): **Návrh servisní desky trakční baterie elektromobilu**

Theme title (in English): Service Board Design for a Traction Battery of a Battery
Electric Vehicle

Guides for elaboration

During the elaboration of the master's thesis follow the outline below:

- Study passive and active balancing of cells connected in series into traction battery
- Discuss principle of an individual cells charging
- Propose algorithm of the cells balancing with an additional charger
- Design HW and SW of the service board for the balancing of series cells based on BMS data
- Discuss the results

Graphical work range: Printed Circuit Board design drawings

Accompanying report length: At least 55 pages

Bibliography: Glaize C., Genies S.: Lithium Batteries and Other Electrochemical Storage Systems, ISTE, UK, 2013
Leso M., Sadil J.: Analýza a návrh aplikace akumulátorů pro elektromobil, Elektro 6/2013, p. 6-11
Záhlava V.: OrCAD 10, Grada, 2004
Matoušek D.: P.s m. Atmel ATmega16,4. díl, BEN, 2006

Master's thesis supervisor: **Ing. Jindřich Sadil, Ph.D.**
doc. Ing. Martin Leso, Ph.D.

Date of master's thesis assignment: **July 21, 2015**
(date of the first assignment of this work, that has be minimum of 10 months before the deadline of the theses submission based on the standard duration of the study)

Date of master's thesis submission: **June 1, 2016**
a) date of first anticipated submission of the thesis based on the standard study duration and the recommended study time schedule
b) in case of postponing the submission of the thesis, next submission date results from the recommended time schedule

doc. Ing. Pavel Hrubeš, Ph.D.
head of the Department
of Transport Telematics

prof. Dr. Ing. Miroslav Svítek, dr. h. c.
dean of the faculty

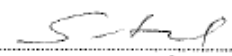

I confirm assumption of master's thesis assignment.

Bc. Josef Černý
Student's name and signature

Prague July 21, 2015

Declaration

I have no relevant reason against using this schoolwork in the sense of § 60 of Act No121/2000 concerning the authorial law.

Place, date

Prague, 31.5.2016

Name and signature

Josef Černý

Declaration

I declare that I have accomplished my final thesis by myself and I have named all the sources I had used in accordance with the guideline about the ethical rules during preparation of university final theses.

Place, date

Prague, 31.5.2016

Name and signature

Josef Černý

Full bibliographical identification

Černý, J. (2016). *Service board design for a traction battery of a battery electric vehicle*. Prague: Czech Technical University in Prague, Faculty of Transportation Sciences. Master's Thesis Supervisors: Ing. Jindřich Sadil, Ph.D., doc. Ing. Martin Leso, Ph.D.

Key terms

BEV, individual balancing, traction battery, Service board

Abstract

The thesis describes a design of a new additional balancing system called the Service board. This balancing system differs from conventional balancing methods, such as passive and active ones, because of its original architecture and individual approach to every battery cell. These facts ensure economically beneficial balancing with the highest precision. Since the author uses an individual approach to balancing, the Service board is meant for maintenance purposes rather than a substitution of the conventional balancing system for everyday charging. The Service board is designed for a specific case study of Citroën Saxo, although it can be connected to every battery electric vehicle.

Acknowledgement

The author would like to thank Ing. Jindřich Sadil, Ph.D., and doc. Ing. Martin Leso, Ph.D., for their constructive feedbacks to the thesis. All mutual discussions about the design of the Service board have been especially valuable to the author.

Content

1	Introduction.....	12
1.1	Motivation.....	13
1.2	Expected features of the Service board	14
2	Balancing methods.....	16
2.1	Passive balancing.....	17
2.2	Active balancing	18
2.2.1	Buck-boost.....	18
2.2.2	Single windings transformer balancing topology	19
2.3	Individual balancing	20
2.4	Comparison of balancing methods	21
3	BEV and Traction batteries.....	23
3.1	BEV Citroën saxo	23
3.2	BMS of Citroën saxo	25
3.2.1	Passive balancing with discharge transistors	25
3.2.2	Problem description	26
3.3	Battery cells	27
3.3.1	Cell parameters	28
3.3.2	Charge/Discharge cycle	29
4	Hardware solution	31
4.1	Conceptual model	31
4.2	Wi-Fi block.....	32
4.3	Microprocessor block	34
4.3.1	Ports description	35
4.4	Multiplexors block.....	38

4.5	Relays block.....	40
4.6	Charger Block.....	41
4.7	Power supply block.....	44
5	Software solution	46
5.1	The Service board algorithm	46
5.2	Voltage measurement + AD converter	48
5.3	Change of battery cell	50
5.4	Shift registers control.....	51
5.5	On-board unit's program	53
6	Results and discussion	54
7	Conclusion	58
8	References.....	59
	List of appendixes	60

List of tables

Table 1: Expected features of the Service board	14
Table 2: Advantages and disadvantages of cell battery balancing methods (Daowd, Noshin, Bossche, & Mierlo, 2011).....	22
Table 3: LiFeYPO ₄ parameters (EV-Power.eu, nedatováno).....	28
Table 4: Defined commands of communication.....	33
Table 5: Wi-Fi programmer's connector.....	34
Table 6: PORTA.....	36
Table 7: PORTB.....	36
Table 8: PORTC.....	37
Table 9: PORTD.....	38
Table 10: The Charger characteristic.....	42
Table 11: Voltage supplied parts	44

List of figures

Figure 1: Cell balancing (Daowd, Noshin, Bossche, & Mierlo, 2011)	16
Figure 2: Common passive balancing (Kristaps, 2014)	17
Figure 3: Buck-boost d.c converters (BBC) cell balancing topology (Daowd, Noshin, Bossche, & Mierlo, 2011).....	19
Figure 4: Single windings transformer balancing topology (Daowd, Noshin, Bossche, & Mierlo, 2011).....	20
Figure 5: Individual balancing - electrical scheme.....	21
Figure 6: Citroën Saxo disposition (modified, http://moto.pl/MotoPL/51,88389,7010645.html?i=3).....	24
Figure 7: Passive balancing with the discharge transistors	25
Figure 8: process of passive balancing	26
Figure 9: Photo of LiFeYPO ₄ (EV-Power.eu, nedatováno).....	28
Figure 10: Discharge and charge characteristic of LiFeYPO ₄	29
Figure 11: Principle of the LiFePO ₄ cell operations (Glaize & Geniès, 2013).....	30
Figure 12: Conceptual model	32
Figure 13: Wi-Fi programmer	33
Figure 14: ATmega32 (Atmel Corporation).....	35
Figure 15: JTAGICE connector (Atmel Corporation).....	37
Figure 16: Multiplexer.....	39
Figure 17: Shift register	40
Figure 18: Relay connection.....	41
Figure 19: Intermittent charging.....	42
Figure 20: Charging characteristic of the Service board	43
Figure 21: SPI communication (Microchip).....	44
Figure 22: The Service board algorithm.....	47
Figure 23: Voltage measurement electrical scheme	48
Figure 24: Voltage measurement algorithm	49
Figure 25: Cell connection algorithm	51
Figure 26: Shift registers algorithm.....	52
Figure 27: On-board control program	53
Figure 28: Prototype of the Service board.....	56

Abbreviations

BEV	Battery electric vehicle
BMS	Battery management system
SMD	Surface Mount Device
SOC	State of charge

1 INTRODUCTION

Not only does the battery electric vehicle have a great future ahead, but it also has an impressive history. The first idea of the battery electric vehicle (BEV) was originally realized by Thomas Davenport. The BEV was built in 1834 and it used non-rechargeable batteries. Up until the end of the 19th century, the BEVs held the land speed record. At that time, the very first car dealer specialized exclusively on BEVs. The fact that there was no access to electricity in the countryside in the beginning of the 20th century – in combination with the invention of the electric starter for combustion engines – resulted in total domination of combusting engines over the electric ones. This situation buried all efforts for BEV development for several decades. In the late 70's, the BEVs were back in the game with the invention of new rechargeable batteries and increasing awareness of pollution.

In these days, battery technologies promise increasing live cycles, extended battery life and recharging within short periods of time. Aside from these extraordinary parameters, what if a battery cell fails? The cells in battery boxes are connected into the series with an aim to achieve ideal conditions for saving a large amount of energy. Besides, a well-known proverb says: “The chain is only as strong as its weakest link.” That is the reason why balancing methods were developed. These methods are trying to keep all cells in the same condition. But what can we do if the conventional balancing methods are not sufficient?

The aim of this thesis is to propose a new service balancing system called the Service board, based on an approach of individual balancing. In contrast to conventional methods of balancing, such as the active balancing methods (based on a process of active transmission energy between cells) or the passive methods (which transform the excess energy into heat), the proposed individual balancing system is equipped with its own power source. This guarantees effectiveness of the balancing process, without any unnecessary energy loss and with the highest precision.

The individual balancing methods offer a possibility to connect each battery cell to the power source separately. This approach automatizes the manual process that requires opening of the battery box, identifying the wrong battery cell and recharging the cell onto a certain voltage level. The Service board serves exclusively for maintenance purposes when failure occurs. It is not designed to supplement other conventional balancing methods but to

cooperate with them or to inspect them. The Service board is *de facto* a fully working battery management system (BMS).

As an outcome of this thesis, a hardware design of the Service board will be created together with a suitable software solution. The hardware design of the Service board will be created by using Orcad 10.5 tool. A 8-bit microcontroller will be used as a master control unit of the Service board and it will be programmed in AVR studio 4. The hardware and software designs have to be equipped with safety functions preventing the battery cells from a risk of damage – especially in cases of cell overcharging, of a short-circuit over cell, or simply when the microcontroller stops working. The Service board should also be utilized with a wireless module through which the data and the control signals are exchanged with an on-board unit inside the BEV.

The Service board should be able to work in two modes: firstly, balancing the battery cells automatically without any human intervention, and secondly, letting the operator choose which cell should be balanced at the moment. A proposal of a graphical interface for a touchscreen on-board unit is also a part of the design. This interface will be utilized with control buttons and information about the state of charge.

1.1 MOTIVATION

The Service board is primarily designed for BEV Citroën Saxo that is owned by one of this thesis' supervisors doc. Ing. Martin Leso, Ph.D. A failure has occurred in the BEV after several thousand km and one of the battery cells had to be replaced. This led to misbalanced states between battery cells. The differences between the new cell and the old ones have been continuously widened and the current battery management system – based on a passive balancing method – struggled to handle them (the problem is closely described in chapter 3.2.2 Problem description). It led to more and more frequent disassembling of the battery boxes and balancing of the cells by an additional charger. The procedure of opening the battery boxes is quite complicated as the boxes can weight up to 200kg and are not designed for frequent disassembling.

The BEV driving distance had been shortened and the battery cells were constantly misbalanced. One of the ways to regain the lost performance was to buy a whole packet of new cells. In that moment the idea of automatized maintenance individual balancing system arose, because it would have been very ineffective and expensive to buy a whole new packet

of battery cells due to a failure of one battery cell. The Service board can be connected to the battery cells via a connector placed on the battery boxes created solely for the purpose of the Service board. The maintenance balancing system aligns the level of voltage to the exact same level with precision up to 0,002V. After this procedure, the BEV works more efficiently, it prolongs its distance, saves energy and extends a life cycle of the battery cells. Since the Service board will be utilized with more precise measurement of voltage than the current BMS, there is no need to connect the new system to the BMS in Citröen Saxo. Therefore, the Service board is not dependent upon any of the BEV's systems at all.

1.2 EXPECTED FEATURES OF THE SERVICE BOARD

Table 1: Expected features of the Service board

No.	Features
1	Complementary balancing system.
2	Measurement of the voltage level.
3	Measurement of the current level.
4	Proper power source of balancing.
5	Connection to each battery cell separately.
6	Wireless communication with the current BMS and the board computer in the BEV.
7	Capability of the manual and automatic balancing.

1. Complementary balancing system

The Service board is designed for the BEV with existing BMS. The purpose of the Service board is not to substitute already established BMS, but to check whether the BMS works properly and also to balance the battery cells at higher precision than the present BMS does. Therefore, the idea of the Service board usage is to deal with corresponding failures and to balance with higher precision.

2. Measurement of the voltage level

The Service board has its own methods to measure the voltage level of the battery cells. This measurement is by one digit more accurate than the former measurement provided by the BMS. The Service board is utilized with A/D convertor with precision up to 0,001V.

3. Measurement of the current level

The Service board is able to measure a current during the balancing cycle. For the current measurement, the same A/D convertor is used. The precision of the current measurement is up to 0,1A. As the power source is a supply of stable current, the level of current has only an informative character. Higher precision is not necessary.

4. Proper power source of balancing

The power source of the battery cells balancing delivers a stable current during the process of cells balancing. The source is controlled by a microprocessor on the Service board in order for it not to do any harm to the battery cells and to ensure maximum efficiency.

5. Connection to each battery cell separately

In terms of an individual approach to the battery cells, each cell is connected to the Service board separately.

6. Wireless communication with the current BMS and the board computer in the BEV

The Service board is utilized with a wireless communication protocol to exchange information about the state of the battery cells or the state of the balancing process with the control unit in the BEV. The Service board is controlled by using this wireless protocol from the BEV's control unit.

7. Capability of the manual and automatic balancing

The Service board provides a choice either of manual or automatic balancing. With automatic balancing, the Service board automatically selects the order of the cells during the process of balancing. The second option – manual balancing – means that the user can choose which cell will be balanced.

2 BALANCING METHODS

The balancing of battery boxes is a rather comprehensive topic. It requires knowledge from fields such as chemistry, physics, mathematics and electronics. Several methods have been already invented, as it is indicated in the next figure. The following chapter does not describe each of those methods, solely because the topic would deserve its own thesis. That is why, in this chapter, only the main differences between active and passive balancing methods are presented closely.

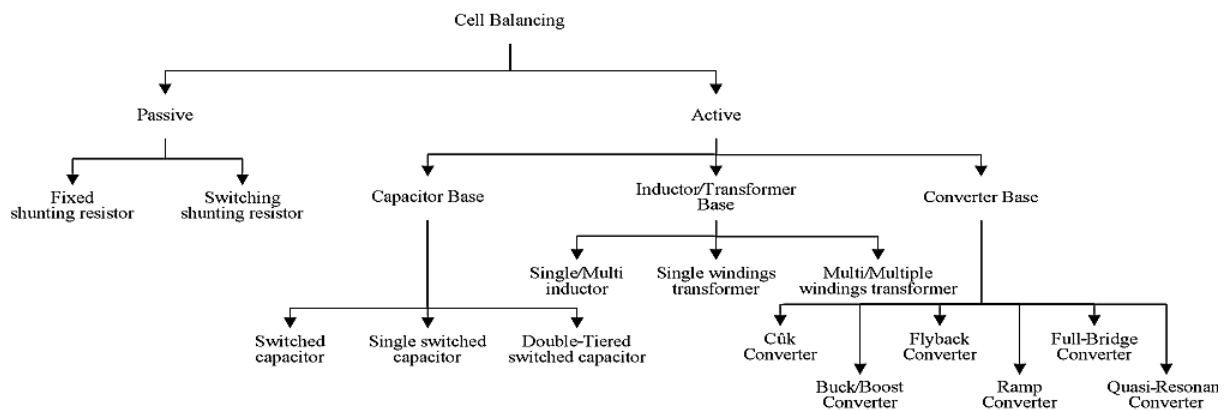

Figure 1: Cell balancing (Daowd, Noshin, Bossche, & Mierlo, 2011)

The active balancing has its core in the active way of transmitting energy. The stronger cells supply the weaker ones with voltage. This method is usually quite time-challenging, especially when it is required to transfer energy from the first cell to the last one. In this case, the energy travels from the first cell to the second, then from the second to the third etc., until it reaches the last one.

The opposite technique is the passive balancing method. The passive method does not transfer energy from one cell to another. During the process of cells charging, when the stronger cells are already fully charged and the weaker ones are not, the fully charged cells are shorted via resistor and the excess energy is transformed into heat. This method is easier and also cheaper than the active one. Nevertheless, the created loss is expensive and changes, such as temperature changes, can do harm to the battery cells. The remaining method, less known and explored, is called individual balancing. This method is constructed especially for maintenance purposes and cannot stand alone as the BMS in BEV. Still, it does not create unnecessary heat losses and is fairly quick. This method is designed in a way that it is

possible to balance only one cell at the time but with a higher accuracy, efficiency and current (hence it makes the process quicker) than the two methods mentioned above.

2.1 PASSIVE BALANCING

One of the most common methods to implement the passive balancing process of battery cells is known as the shunting resistor balancing method. For the purpose of this thesis, the shunting resistor method is used as a prime example of passive balancing. A functional diagram of this method is shown in the next figure. The fundamental idea of this method is to connect each cell with a switch that allows the cell to bond with a resistive element. When the cell reaches a certain threshold voltage level, the resistive element connects across the cell via the switch. As a result, the cell is discharging until its voltage level decreases below certain voltage limit. Then the switch changes its state and the cell is charged again. The excess energy (the loss) is then transformed via the resistor element into heat.

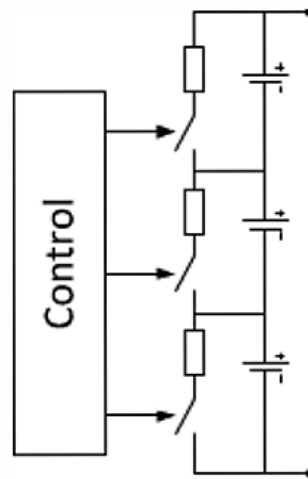

Figure 2: Common passive balancing (Kristaps, 2014)

This method is quite popular in many applications, mostly thanks to its simple and low-cost implementation. Passive methods are commonly used for balancing relatively small cells, such as the ones in laptop computer battery pack. Thanks its simplicity and favourable price, it is common to found this balancing method in BEVs as well.

2.2 ACTIVE BALANCING

Conversely to the passive balancing, the active balancing methods do not create such a big loss in the form of heat. These methods are based on active transport of energy among cells. Instead of energy combustion across fully charged cells, the excess energy is used to charge other cells. Consequently, the fully charged cell supplies the battery cells circuit with its own energy. Therefore, this cell serves as a power supply for the less charged ones. These methods of active balancing are more benevolent, in terms of used battery cells technology. They are not dependent on chemical characteristics of the cells and can be used for most types of battery cells.

As you can see from Figure 1, the family of active balancing is much bigger than the family of passive balancing. It is hard to present features of this family, because every method has a different approach to solving the problem. Two methods that have similar features and ideas to the Service board design are described below.

2.2.1 BUCK-BOOST

Buck¹-Boost² DC Converter topology can work either with groups of battery cells (Modules) or with a single battery cell. The excess energy is saved into an external battery and afterwards transferred to the weakest battery cell.

¹ Step down

² Step up

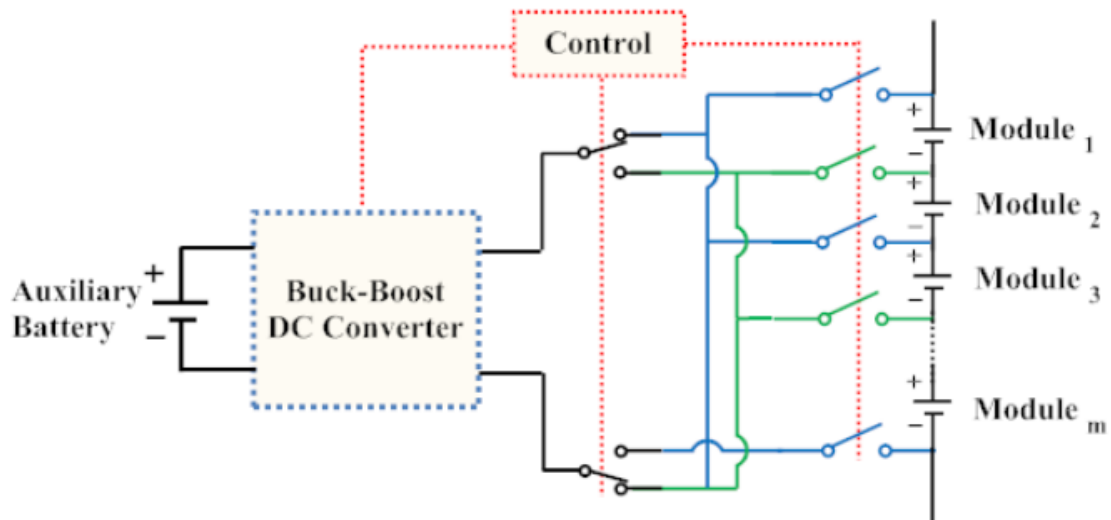

Figure 3: Buck-boost d.c converters (BBC) cell balancing topology (Daowd, Noshin, Bossche, & Mierlo, 2011)

This topology has high demands on control, in terms of a high complexity of the algorithm. Consequently, this fact increases the price. However, its high efficiency and suitability for modular design is what makes this topology so popular.

2.2.2 SINGLE WINDINGS TRANSFORMER BALANCING TOPOLOGY

The single windings transformer balancing topology has two ways of balancing cells. First technique is based on transferring energy from all battery cells to the weakest ones through the switching transformer. The second technique is different; the excess energy is transferred from the strongest cell into the whole battery pack.

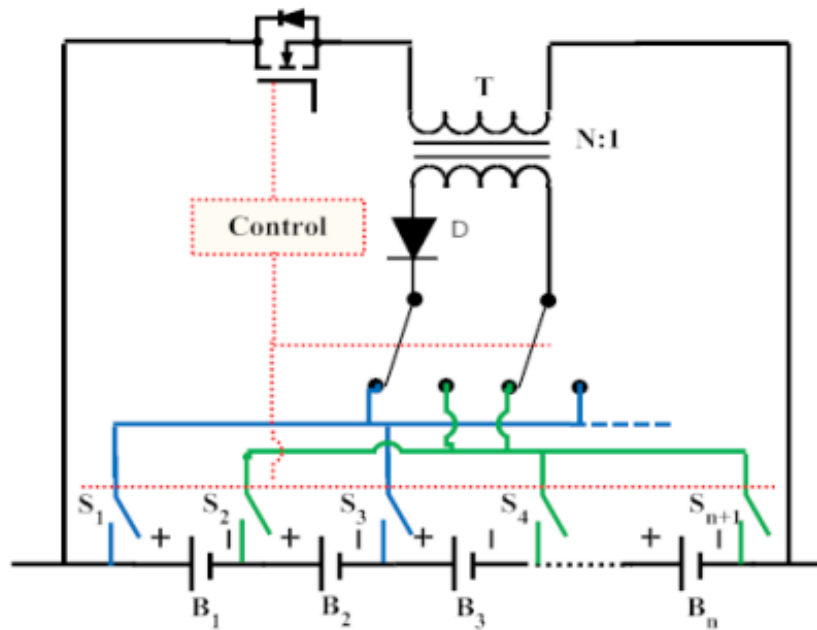

Figure 4: Single windings transformer balancing topology (Daowd, Noshin, Bossche, & Mierlo, 2011)

This method is quite inflexible in terms of battery cells number. By changing the number of battery cells, the transformer core has to be appropriately altered.

2.3 INDIVIDUAL BALANCING

The proposed individual balancing is rather a type of the active balancing than the passive one. It works without burning the excess energy into the form of heat. Therefore, it does not correspond with the passive balancing. Then again, the individual balancing does not work with the active transferring of energy between the cells in the same way as the active balancing does. It uses its own power source to balance the cells. Accordingly, it could be also called an individual charging. For this reasons, it is neither the active balancing, nor the passive one and would thus deserve its own category – individual balancing.

Nevertheless, this method can never fully substitute a battery cell charger in BEV. Individual balancing is able to balance/charge only one cell at the same time. The time needed to charge every cell from 0 to 100% would be up to n times longer, where n is a number of battery cells. What's more, the charger for series connected cells requires a cable with an area approximately 1.5 mm^2 dependent on the amount of current. With individual balancing used as a charger, it would require n times bigger area of cable due to n times higher current (we

can compare it to the parallel connection), where n is a number of cells. These facts exclude the possibility of the usage of individual balancing instead of a primary charger.

The simplified electrical scheme of the proposed individual balancing is present in Figure 5.

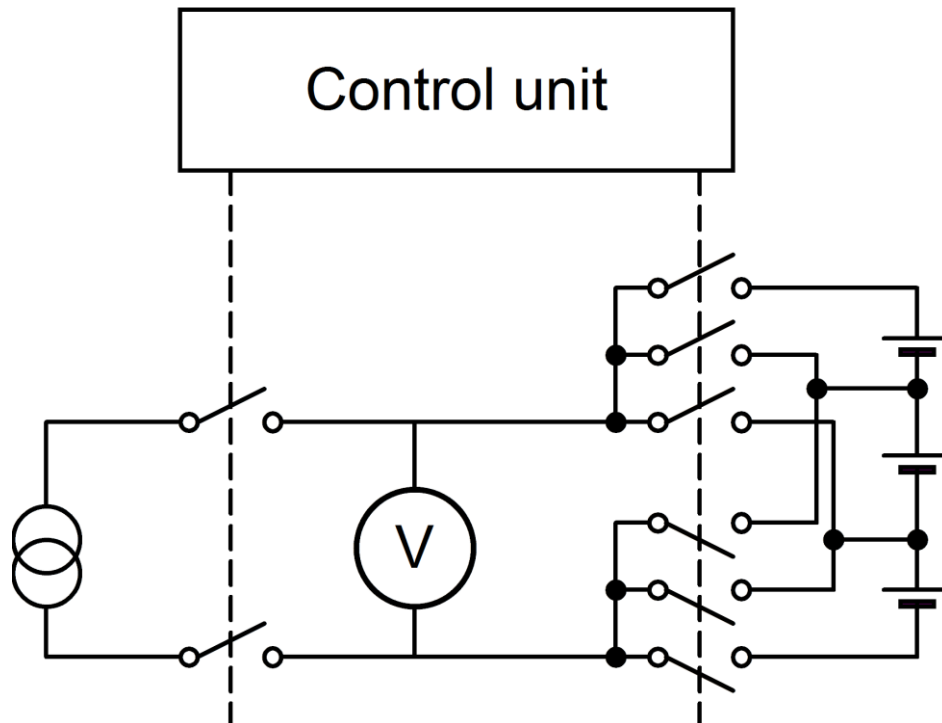

Figure 5: Individual balancing - electrical scheme

The presented individual balancing requires $2 \cdot n$ switchers, where n is a number of the battery cells. Thanks to an individual approach, it allows a higher precision than other methods, but is able to balance only one cell at the same time.

2.4 COMPARISON OF BALANCING METHODS

As a summary of this chapter, the conclusion of research done by Daowd, Noshin, Bossche and Mierlo (2011) will be presented. They have tested all methods shown in the tree graph in Figure 1, and evaluated their advantages and disadvantages.

Table 2: Advantages and disadvantages of cell battery balancing methods (Daowd, Noshin, Bossche, & Mierlo, 2011)

Scheme	Advantage	Disadvantage
1. Fixed Resistor	• Cheap. Simple to implement with a small size.	• Not very effective. Inefficient for its high energy losses.
2. Shunting Resistor	• Cheap, simple to implement and Fast equalization rate. • Charging and discharging but not preferable for discharging. • Suitable for HEV but for EV a 10mA/Ah resistor specified.	• Not very effective; Relatively high energy losses • The requirement for large power dissipating resistors. • Thermal management requirements.
3. Switched Capacitor	• Simple control. Charging and discharging modes. • Low voltage stress, no need for closed loop control.	• Low equalization rate. • High switches number.
4. Single Switched Capacitor	• Simple control. Charging and discharging modes. • One capacitor with minimal switches. EV and HEV app.	• Satisfactory equalization speed. • Intelligent control is necessary to fast the equalization.
5. Double Tiered Switched Capacitor	• Reduce balancing time to quarter than the switched capacitor. • Charging and discharging modes. EV and HEV applications.	• Satisfactory equalization speed. • High switches number.
6. Modularized Switched capacitor	• Low voltage and current stress. • Charging and discharging modes	• Complex control is needed. • Satisfactory equalization speed.
7. single Inductor	• Fast equalization speed.	• Complex control is needed. Switches current stress. • Filtering capacitors are needed for high switching frequency.
8. Multi Inductor	• Fast equalization speed. • Good efficiency	• Less complex control. Needs accurate voltage sensing. • Charging mode only. Switches current stress. • Filtering capacitors are needed for high switching current.
9. Single Windings Transformer	• Fast equalization speed. • Low magnetic losses.	• High complexity control. Expensive implementation. • To add one or more cells the core must be change.
10. Multi Windings Transformer	• Rapidly balancing. No closed-loop controls are required. • Suitable for both EV and HEV applications	• High cost. Complexity control. • The core will be changed if cell or more are added.
11. Multiple Transformers	• Fast equalization speed. Can be modularized • EV and HEV applications. New cells easily added.	• High cost. Complexity control. • Satisfactory efficiency due to magnetic losses.
12. Modularized Switching Transformer	• Fast equalization speed. Suitable for both EV and HEV. • Low voltage and current stress.	• High cost. • Complexity control.
13. Cuk Converter	• Suitable for both EV and HEV applications. • Efficient equalization system.	• Complexity control. Accurate voltage sensing needed. • Satisfactory equalization speed.
14. Buck-Boost Converter	• Good equalization speed. • Easy for modular design.	• High cost • Intelligent control needed.
15. Flyback Converter	• Easy implemented for large number of cells. • EV and HEV application. Suitable modularized system.	• Voltage sensing needed. • Satisfactory equalization speed.
16. Ramp Converter	• Soft switching along with a relatively simple transformer.	• Complex control. Satisfactory equalization speed.
17. Full-Bridge Converter	• Fast equalization speed. • Ideal for transportation applications	• High cost • Intelligent control needed.
18. Quasi-Resonant Converter	• Low switches current stress that increases its efficiency. • Simple implementation.	• High cost • Complex and intelligent implementation needed.

From the previous table it is obvious that it is not easy to choose the correct method, because each one has its own strong and weak points. Similarly, it is quite difficult to find points of intersection in terms of generalizing one or another family of methods. In the following table, you can find pros and cons which can be applied to the majority of methods as they were distinguished as an active, passive or individual group of balancing methods.

	Active Balancing	Passive balancing	Individual balancing
Price	-	+	-
Simplicity	-	+	-
Energy loss (heat)	+	-	++
Non-dependent on chemical characteristics	+	-	+
Effectiveness	+	-	++
Precision	+	-	++
Capable balance more than one battery cell at a time	+	+	-

3 BEV AND TRACTION BATTERIES

This chapter contains information about BEV Citroën Saxo for which the Service board was primarily designed.

3.1 BEV CITROËN SAXO

- Year of production: 2001
- Electric commutator engine 20kW
- 42 battery cells
- Range circa 100km

The BEV is equipped with 42 battery cells in three battery boxes. The rear box contains 22 cells (in Figure 6 number 8) and the two front ones (in Figure 6 number 2) contain 4 (upper box) and 16 cells (lower box). Used battery cells LiFeYPO_4 are closely described in the chapter 3.3. Each battery cell can be charged up to 3.8V. Continuously, the car can dispose up to 159.6V.

The main control unit of BEV Citroën is SAGEM system (Figure 6 number 3) that coordinates every function in BEV from charging with BMS (Figure 6 number 9) to steering booster. It communicates with on-board touchscreen computer equipped with Windows XP, which is placed on the middle panel inside the car. The on-board unit can communicate with SAGEM unit, BMS unit and also wirelessly with the Service board. For the purposes of the Service board, the on-board computer is provided with touchscreen graphic application with information about the SOC of the battery cells and several control buttons for charging options.

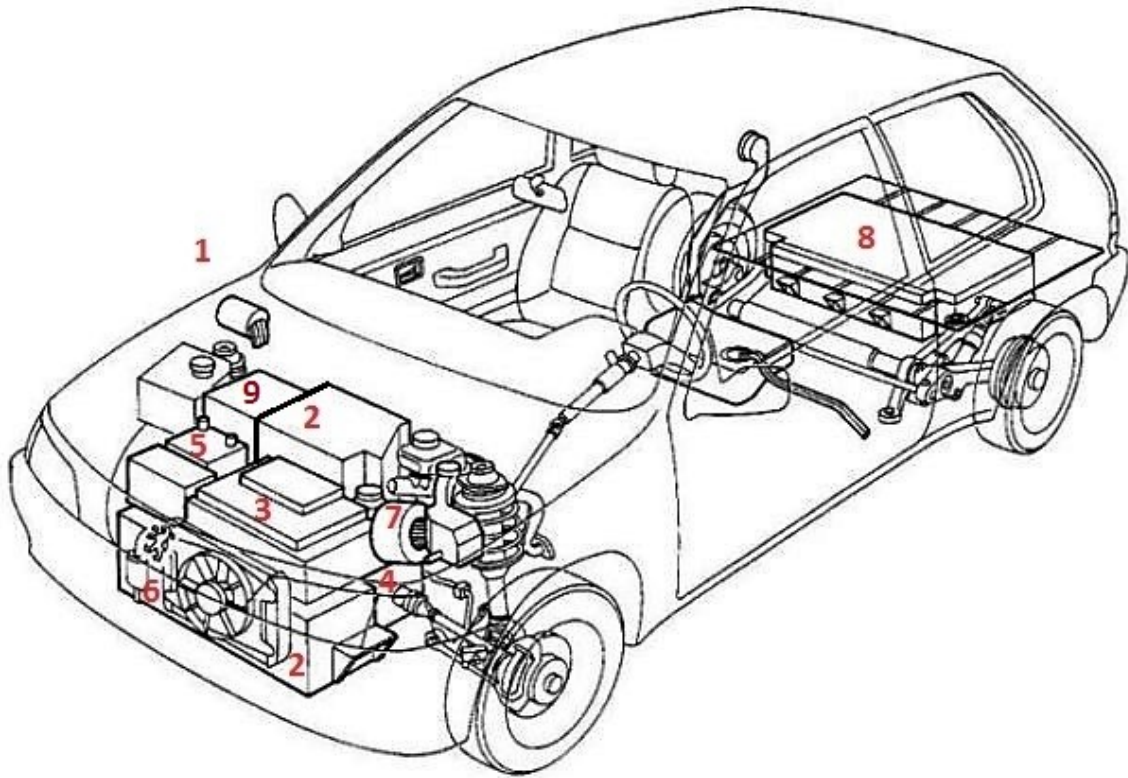

Figure 6: Citroën Saxo disposition (modified, <http://moto.pl/MotoPL/51,88389,7010645.html?i=3>)

Description notes of Figure 6:

1. Power socket
2. Two front battery boxes (4 cells and 16 cells)
3. SAGEM
4. Electric engine
5. Board battery 12V
6. Water cooler of battery boxes
7. Air engine cooler
8. Rear battery box (22 cells)
9. BMS

3.2 BMS OF CITROËN SAXO

Battery management system (abbreviated to BMS) is an electronic system inside BEV. It controls the process of charging and balancing of the rechargeable battery cells.

3.2.1 PASSIVE BALANCING WITH DISCHARGE TRANSISTORS

BEV Citroën Saxo uses a passive balancing system, a similar system to the one presented in chapter 2.1 Passive balancing. The excess energy is burned in the resistor via the discharge transistor. So, when the cell reaches certain threshold voltage level, the transistors burn the excess energy in the resistors.

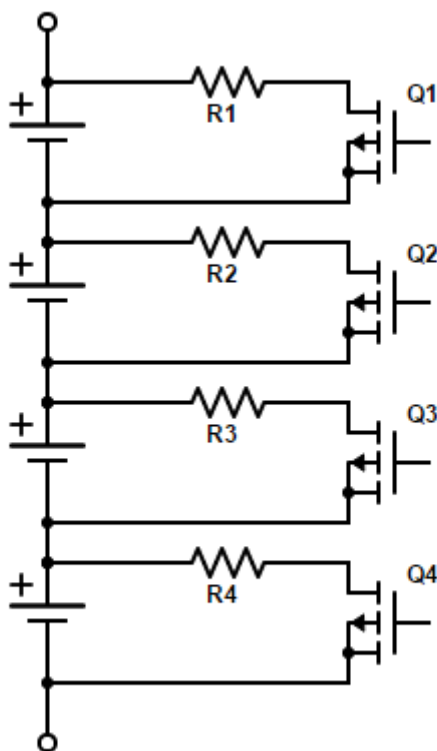

Figure 7: Passive balancing with the discharge transistors

This system usually works more or less without a problem until one cell has to be replaced with a new one. Consequently, unequal conditions for charging and balancing are created.

All 42 cells are connected into the series. As a result, all cells are charged and balanced at the same time. A problem occurs when some of the cells differ (i.e. are newer, older, more used, exposed to higher temperature, etcetera) from the others. These differences change the chemical characteristic of the battery cell, resulting into even bigger dissimilarities with each

cycle of the charging process. The discharge transistors (Figure 7) are capable of 2A maximum. According to the charging process in Figure 8, after one cell is fully charged, the others are being continuously charged only by 2A, otherwise the transistors would be burned and a risk of cell damage would arise.

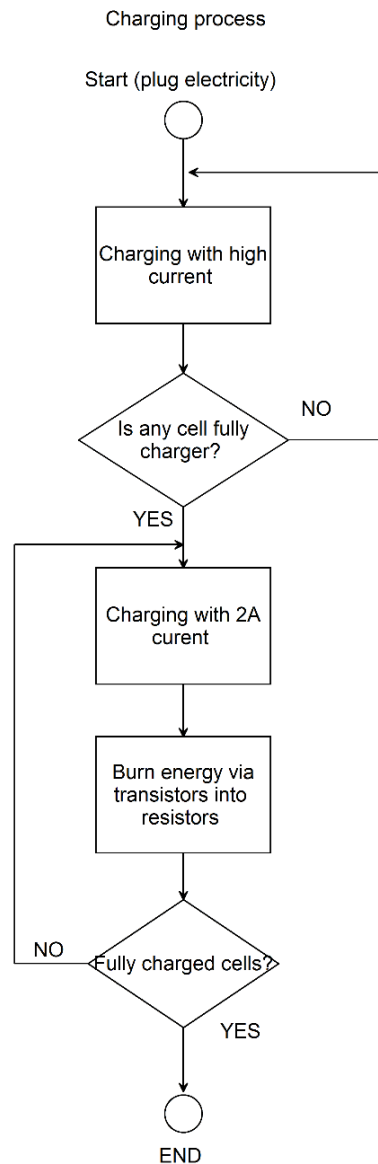

Figure 8: process of passive balancing

3.2.2 PROBLEM DESCRIPTION

The reason for inventing a new additional balancing system is described as follows.

After driving 10 000km with Citroën Saxo, a failure on one of the cells occurred. It led to a replacement of this specific cell with a new one – and thus the unequal condition for charging

and balancing was created. Since then, the problem with unequal charging has become even more prominent.

Example of charging process: The car is discharged and cannot drive any longer. One cell, the newest one, has voltage level at 2,8V (this could be enough for another 20km), but the other 41 cells have voltage level under 2,6V. The BEV is plugged into electricity and the charging process begins. The strongest cell is naturally fully charged very quickly, especially when compared to the other cells. When the strongest cell has its maximum 3,8V, the others have 3,3V and the SAGEM system switches from high current to 2A current. Therefore, it would take another few hours before the discharge transistor of the strongest and already charged cell is fully loaded. The created heat from the resistor also leads to a risk situation, where the transistor is overheated and the whole charging process has to be stopped due to a possible damage to battery cell. Consequently, the BEV ends the charging process with one cell charged to 3,8V (i.e. fully charged) and the rest at 3,7V, which again decreases the driving distance and shortens the battery cells life cycle.

A contrary example: The BEV has fully charged 41 of its battery cells, but one is still not at the maximum level. In the rear cell box the situation will be the worst. The 22 battery cells are all burning the excess energy into the resistors. The 22 battery cells \times 2A \times 3,8V (charging voltage) create in total 167,2W of energy in the box of the size of a small cabinet. This heat is dangerous not only for the discharging transistors, but it can also make permanent changes of chemical reactions inside the battery cells.

With the new additional balancing system (Service board), there is no threat of such a damage since there is no heat loss. Moreover, the Service board balancing current is almost three times higher than 2A, which could in many cases lead to a faster balancing process.

3.3 BATTERY CELLS

The proposed Service board is created for 42 cells based on a Lithium-ion iron phosphate technology with an Yttrium addition (LiFeYPO₄). Since the technology is the same for the battery cells with or without Yttrium, this chapter explains the technology generally, based on better-known technology of LiFePO₄ (without Yttrium).

3.3.1 CELL PARAMETERS

The cells based on LiFePO_4 technology are high power lithium cells, original Winston Battery products with capacity of 160Ah. One cell weights 5.8kg, which makes a total of 243.6kg of 42 battery cells in the BEV without BMS components. The price is circa 220\$ per one cell. The nominal voltage of the cell is 3.2V and the operation voltage is between 2.8V and 3.8V. Although the maximum charging voltage is 4V, it is recommended not to overstep the operation voltage. The operation temperature is from -45°C to 85°C . These battery cells have no memory and thus can be recharged at any state of discharge.



Figure 9: Photo of LiFeYPO_4 (EV-Power.eu, nedatováno)

Other notable parameters of the LiFePO_4 cell:

- they have good chemical and thermal stability,
- they are cheap and easy to produce.

Table 3: LiFeYPO_4 parameters (EV-Power.eu, nedatováno)

Parameter	Value
Capacity	160Ah
Weight	5.8 kg
Price	220 \$
Nominal voltage	3.2 V

Operation voltage	2.8 V 3.8 V
Maximum charging voltage	4 V
Operation temperature	-45° C +85° C

3.3.2 CHARGE/DISCHARGE CYCLE

The LiFeYPO_4 provides low resistance with good electrochemical performance. This is achieved by phosphate cathode material. The lithium battery cells are usually more tolerant to full charge conditions; this is especially valid for the lithium-phosphate ones, low self-discharge and very good safety behaviour.

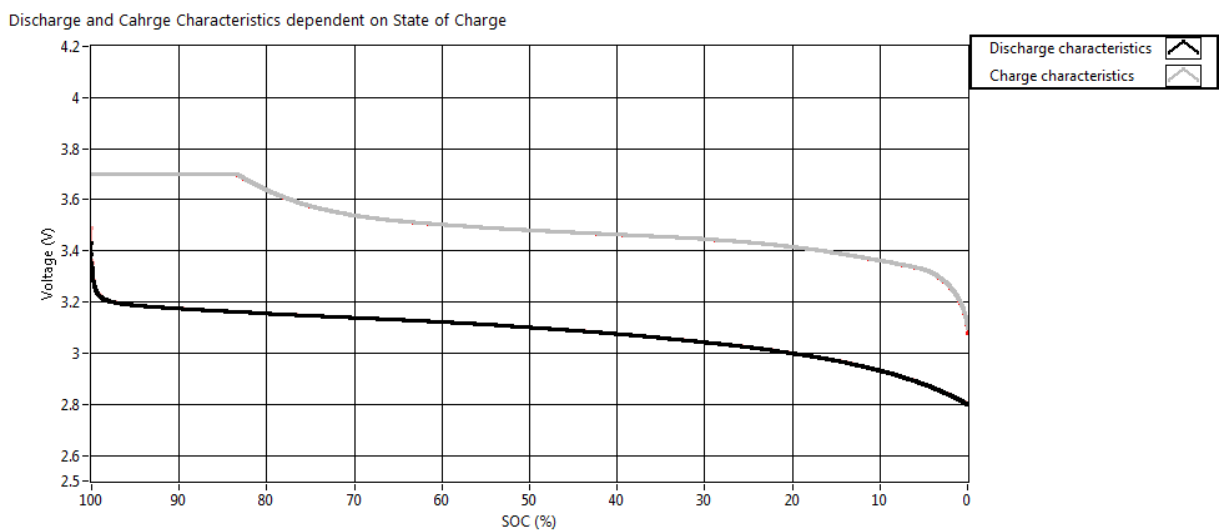

Figure 10: Discharge and charge characteristic of LiFeYPO_4

Unfortunately, the temperature has big impact on chemical operations of these cells. Cold temperatures or reversely extremely high temperatures reduce the performance and significantly shorten the battery life cycle. The charge/discharge cycle is shown in Figure 10. The cycle was measured by stable temperature of 25°C. During the discharge cycle, the sudden drop of in voltage level is clearly visible in the moment of load connection. This effect works on both sides as it is shown in Figure 19, where the intermittent charging was performed. The chemical principle of LiFePO_4 is revealed in Figure 11.

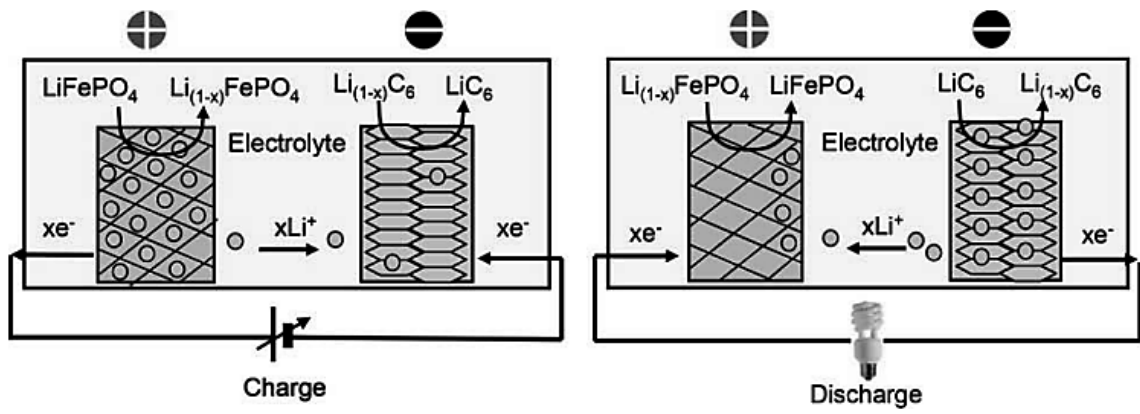

Figure 11: Principle of the LiFePO₄ cell operations (Glaize & Geniès, 2013)

4 HARDWARE SOLUTION

4.1 CONCEPTUAL MODEL

This chapter contains a conceptual model of the proposed balancing system (Service board) and its description. The whole system is composed of 6 function blocks:

- Wi-Fi – transfers information between the on-board computer of BEV and the Service board.
- Microprocessor – the control unit of the Service board.
- Multiplexors – an extension of microprocessor’s output, also contains informative LEDs of the state of the charging process.
- Relays – actuators which connect charger with a specific battery based on microprocessor’s algorithm.
- Charger – power source designed for cell balancing.
- Power supply – module that creates voltage of 3.3V, 5V and 12V. It supplies all components of the Service board with voltage and also provides galvanic isolation.

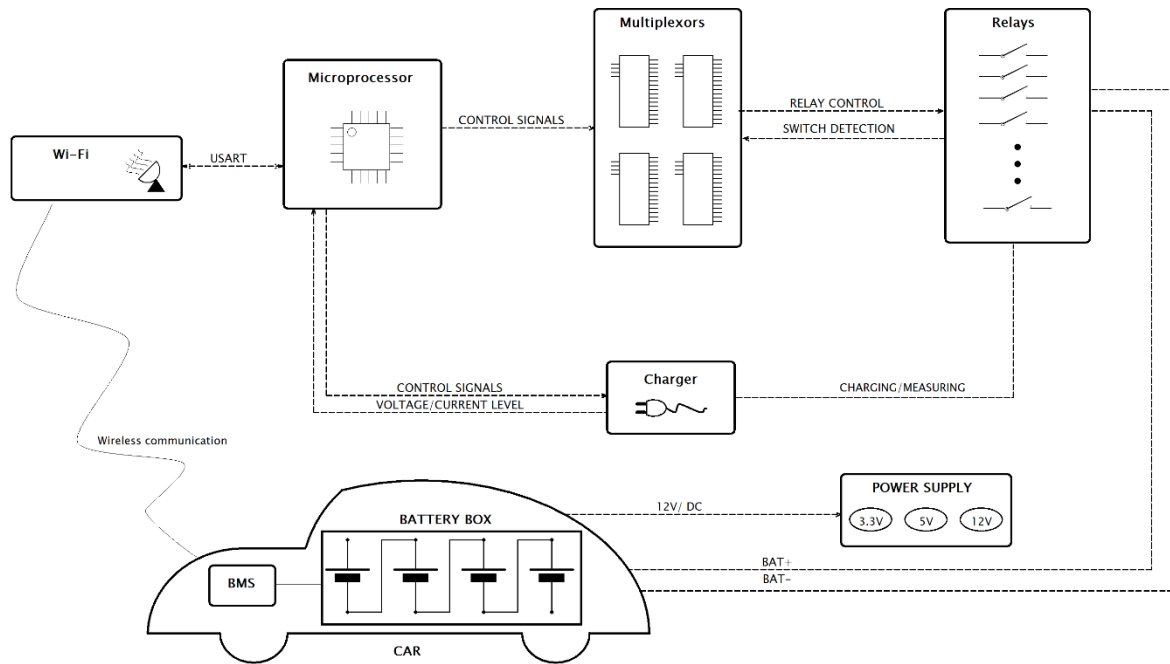

Figure 12: Conceptual model

The Service board's interface with BEV consists of a 12V power supply, an individual connection to each battery cell and a wireless communication between microprocessor of the Service board and the board computer of BEV.

4.2 WI-FI BLOCK

The Wi-Fi block serves as a medium between the microprocessor (the control unit of the Service board) and the on-board computer equipped with a graphic application controlled by a touchscreen. The communication is adjusted to exchange data only between these two devices, no other element has an access to this data. The security of the data transfer is guaranteed via specific IP address for data exchange and WPA2-PSK security of Wi-Fi network.

The communication is based on a set of commands developed especially for purposes of the Service board (Table 4). The commands are transferred in real time to ensure higher precision and cells safety.

Table 4: Defined commands of communication

Incoming commands		Outgoing commands	
Command	Explanation	Command	Explanation
S	Stop charging process	Cx	Chosen battery cell no. x
A	Automatically chose battery cell until every cells are fully charged	Vx	Voltage of battery cell
Mx	Charge battery cell no. x	Ax	Charging current
		R	Balancing process is running

A Wi-Fi module ESP8260 is used as a core of this block. This module provides all benefits of the wireless Wi-Fi communication protocol on 2,4GHz and still preserves its small proportions, which are crucial for SMD application.

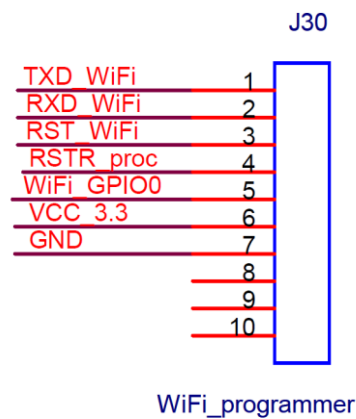

Figure 13: Wi-Fi programmer

The Wi-Fi block disposes of a programmable connector. This connector is used solely for maintenance purposes, such as testing or adjusting a program of the Wi-Fi module ESP8260. The connection of pins is shown in Figure 13 and Table 5.

Table 5: Wi-Fi programmer's connector

Pin	Name	Function
1	TXD_WiFi	Sent data (logic 3,3V)
2	RXD_WiFi	Receive data (logic 3,3V)
3	RST_WiFi	Wi-Fi module reset
4	RSTR_proc	Processor reset
5	WiFi_GPIO0	Programmer pin
6	VCC_3.3	DC 3,3V
7	GND	Ground
8	NC	---
9	NC	---
10	NC	---

NC – not connected

4.3 MICROPROCESSOR BLOCK

The microcontroller ATmega32 together with 16 MHz crystal are used as the heart of the Service board. The ATmega32 is an 8-bit RISC processor with Harvard architecture. It disposes of 32 input/output pins and many hardware features. For the purpose of this thesis, hardware tools are used as timers, serial and SPI communication and watchdog. The Service board requires 28 connected pins; the rest is routed to a connector for optional purposes. Pins PC2 – PC5 are attached to JTAGICE programmable connector.

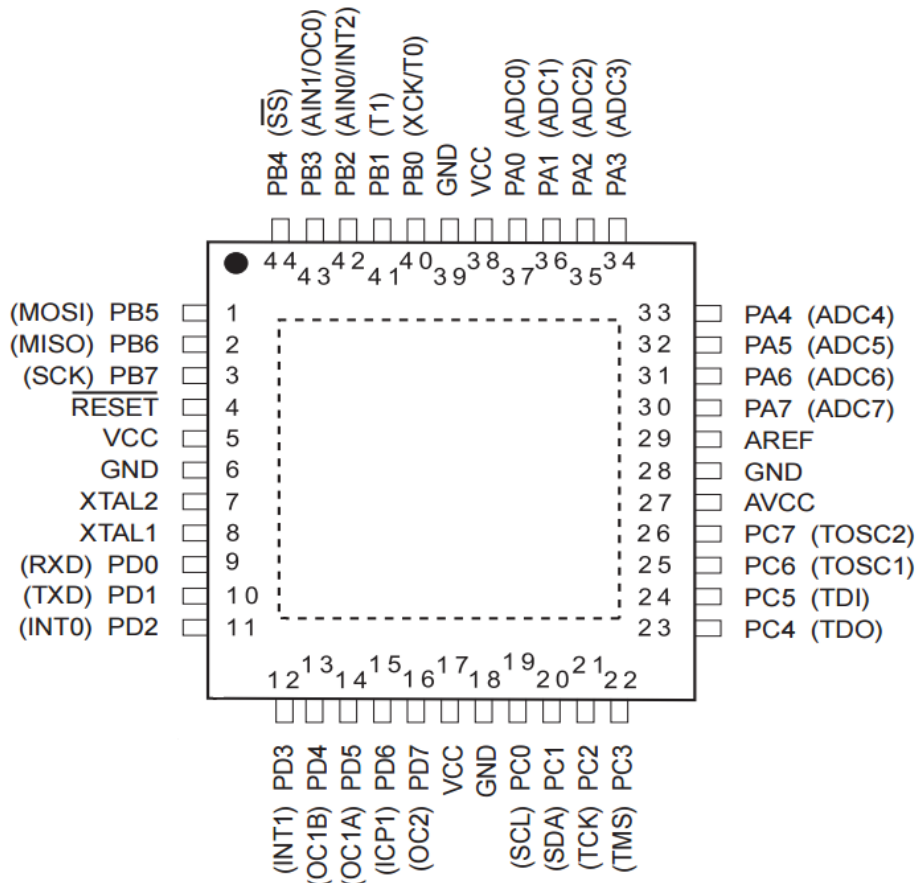

Figure 14: ATmega32 (Atmel Corporation)

4.3.1 PORTS DESCRIPTION

The setting of Ports PA0 – PA3 determines which cell will be connected. These ports lead to multiplexors, an extension of the outputs. Up to 16 cells can be connected to the service desk. Therefore, these ports decide in regards to binary logic: when all ports are empty, it stands for cell no. 1, and when all ports are set to 1, it stands for cell no. 16.

When port PA4 is set to 1, the functions of the connecting multiplexors are enabled and the cell specified by ports PA0 – PA3 can be connected. It is essential to oscillate by PWM with PD5, otherwise the cell cannot be connected.

The ports PA5 and PA6 check if the plus or ground of battery cell is connected. Value 1 stands for “connected” and 0 for “disconnected”. The Port PA7 has to be set to 1 for this function.

When port PA7 is set to 1, the functions of the inspecting multiplexors are enabled.

Table 6: PORTA

PA0	vystup0	Select of cell connection	O
PA1	vystup1		O
PA2	vystup2		O
PA3	vystup3		O
PA4	R_vystup_EN	Enable of cell connection	O
PA5	Dohled_OUT	Start connecting inspection	O
PA6	Dohled_IN	Check if the cell is connected	I
PA7	Dohled_EN	Enable inspection of Correct connection	O

I – input, O – output

Ports PB0 and PB1 control the indicating LEDs. The green light stands for a proper working process and the red one for a failure state.

Ports PB2 and PB3 are routed to a connector for optional applications.

Ports PB4 – PB7 are intended for SPI communication when the microprocessor is set as the master unit. These ports are connected with A/D converter for measuring voltage and current. The SPI data transfer protocol is shown in Figure 21.

In Figure 21, the abbreviation \overline{CS} stands for a chip selection – port PB4, CLK stands for a serial clock – port PB7, D_{IN} is connected to the master output – port PB5 and D_{OUT} to the master input – port PB6.

Table 7: PORTB

PB0	LED RED	Signalizing led of the state of microprocessor	O
PB1	LED GREEN	Signalizing led of the state of microprocessor	O
PB2	Connector	---	NF
PB3	Connector	---	NF
PB4	nSS	Chip select – SPI A/D converter	O
PB5	MOSI	Serial data IN – SPI A/D converter	O
PB6	MISO	Serial data OUT – SPI A/D converter	I
PB7	SCK	Serial clock – SPI A/D converter	O

I – input, O – output, NF – no function

Port PC0 serves for purposes of LED outputs, controlled by two shift registers. When the PC0 is set to 0, the transfer of data into the shift registers can start. After transferring the last bit, the PC0 has to be set to 1 to end the data transfer.

When the value of port PC1 is set to 1, the output of shift registers is enabled. Value 0 forbids the shift register outputs.

PORTS PC2 – PC5 are routed to JTAGICE connector. The connection of the pins is in the following figure.

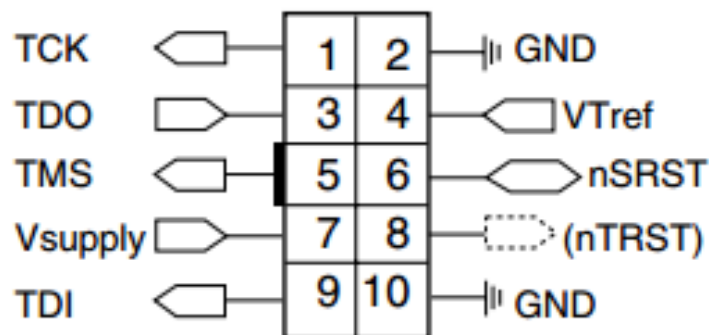

Figure 15: JTAGICE connector (Atmel Corporation)

Port PC6 indicates if the Charger is running (logical 1) or not (logical 0).

Value 1 on port PC7 turns on the Charger, whereas value 0 turns it off.

Table 8: PORTC

PC0	LED STR	Strobe – Shift register	O
PC1	LED OE	Output enable – Shift register	O
PC2	TCK	JTAGICE MKII	I/O
PC3	TMS		I/O
PC4	TDO		I/O
PC5	TDI		I/O
PC6	Detekce_dobijece	Charger running detection	I
PC7	Rele_dobijece DC_ON	START/STOP charger	O

I – input, O – output

Ports PD0 and PD1 are managed by microprocessor’s hardware functions for serial communication. The communication between the microprocessor and the on-board unit runs wirelessly through Wi-Fi module.

Port PD2 controls two high-voltage switches that supply the Charger with 12V from the main power source.

Port PD3 is routed to a connector for optional applications.

Ports PD4 and PD5 are oscillating to switch specific relays connected to battery cell. This safety function is controlled by PWM. When the microprocessor gets stuck in any part of the program, the relay is automatically disconnected to do no harm to the battery cells.

The data can be transmitted through port PD6 into the shift registers.

Port PD7 controls the clock for purposes of the shift registers.

Table 9: PORTD

PD0	RXD	Receive data	I
PD1	TXD	Send data	O
PD2	Rele dobijece	Charger relay	O
PD3	Connector	---	NF
PD4	R_vystup1	Safety lock for charge pump controlled by PWM	O
PD5	R_vystup0	Safety lock for charge pump controlled by PWM	O
PD6	LED DATA	Data – Shift register	O
PD7	LED CLK	Clock – Shift register	O

I – input, O – output, NF – no function

4.4 MULTIPLEXORS BLOCK

The microprocessor utilizes the multiplexors block as an extension of its inputs and outputs. The whole block contains four 16-channel multiplexer (Figure 16) and two 8-channel shift registers (Figure 17). These peripherals extend the amount of inputs and outputs by 32 inputs and 32 outputs via the four multiplexers plus 16 outputs via the two shift registers. In total, it makes an increase of 32 inputs and 48 outputs more.

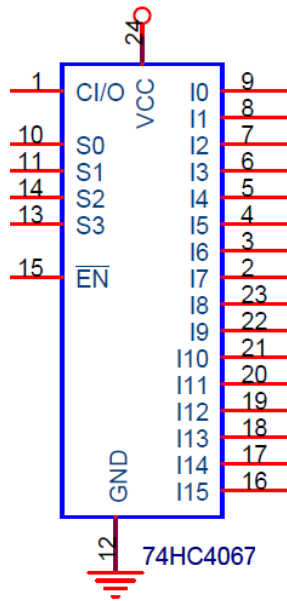

Figure 16: Multiplexer

The two output extending multiplexers determine which cell will be connected by ports PA0 – PA3 (see 4.3.1 Ports description). These ports are routed to pins S0 – S3. Both multiplexers are routed almost in the same way. Yet, pin CI/O (Port PD5) that specifies the value of the multiplexer’s output has to oscillate in the opposite direction. In other words, while the first multiplexor sends value 1, the second has to be sending opposite binary value 0. These values are changed by using PWM modulation. It is a simple safety element, which keeps the charge pump (4.5 Relays block) running.

The other two multiplexers, the input ones, are for an inspection of proper connection battery cells’ pluses and minuses. The control of these multiplexors is the same as in the previous case. The two ports PA0 – PA3 are connected to pins S0 – S3.

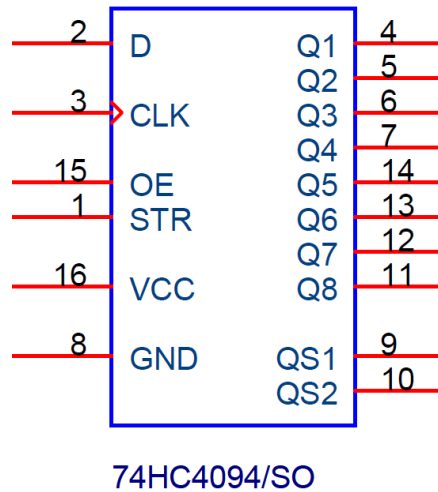

Figure 17: Shift register

The two shift registers are connected in series. The last data bit of the first shift register is the first data bit of the second shift register. The pin connection of shift registers is closely described in chapter 4.3.1 Ports description. The shift registers are in process only when battery cells are connected. Its purpose is to visually show on the Service board which battery cell is connected. When the relevant LED switches on, the battery cell is connected. If the LED is flashing, the charging process is running.

4.5 RELAYS BLOCK

This block contains a set of two relays and one charge pump for each battery cell. As it is shown in Figure 5: Individual balancing - electrical scheme, positive and negative pins of the cell are connected separately, each by its own relay. Still, it is not necessary to have a cable for each pin since the cells are connected in series. For that reason, the Service board uses the cable either for a positive pin of cell no. n or a negative pin of cell no. $n-1$ (see Figure 18: Relay connection). It reduces the amount of cables between the battery box and the Service board to $n+1$ cables, where n is the number of cells.

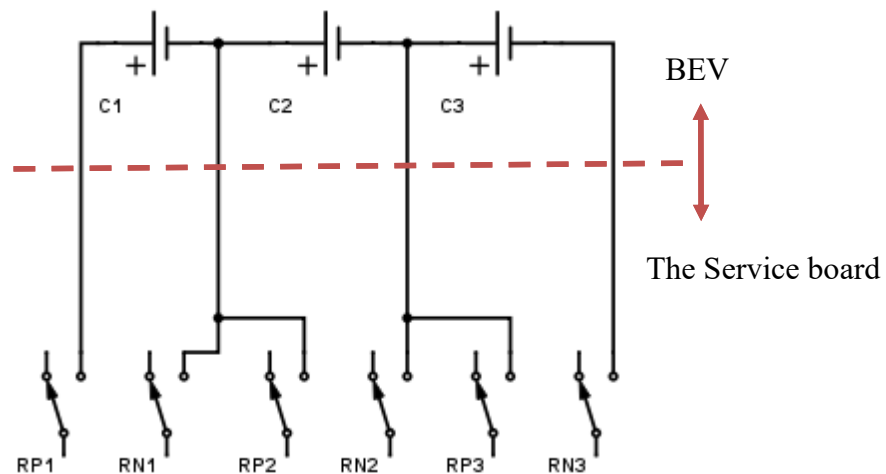

Figure 18: Relay connection

The charge pump controls the common pin of two relays for one cell at a time. However, the safety inspection controls the proper connection of every relay separately. The charge pump provides high safety function in case of the microprocessor's failure. When the charge pump does not receive oscillating signal in a specified frequency, then it immediately disconnects the battery cell. This function ensures a protection against overcharging of the battery, against the microprocessor getting stuck, and against the short-circuit, which could occur if two battery cells are charged at the same time. The second threat is also excluded since the hardware solution of the Service board does not allow to be connected to more than one battery cell.

The relays block interfaces with BEV through cables connected to the battery cells. It does not matter if all slots for battery cells are connected to the Service board or not. The microprocessor software will not work with empty slots and will use only the connected ones.

4.6 CHARGER BLOCK

This block contains all elements needed for a proper process of the battery cells recharging. It disposes with voltmeter and ammeter (A/D converter), high voltage fuse and the Charger providing stable current during charging.

The Charger can be controlled in two ways. According to the scheme in Figure 1, there is a relay that attaches/detaches the Charger to/from the Relays block. The second possibility of

how to run/stop the Charger, is via Port PC7 (Chapter 4.3.1). To ensure safety of the battery cells, both of these functions have to be used to run the balancing process. Port PC6 inspects if the relay was properly switched.

During the standard balancing procedure, the Charger is once per specified period turned off (Figure 19) via port PC7 to measure the accurate voltage of battery cell. More about voltage measuring process can be found in chapter 5.2 Voltage measurement + AD converter.

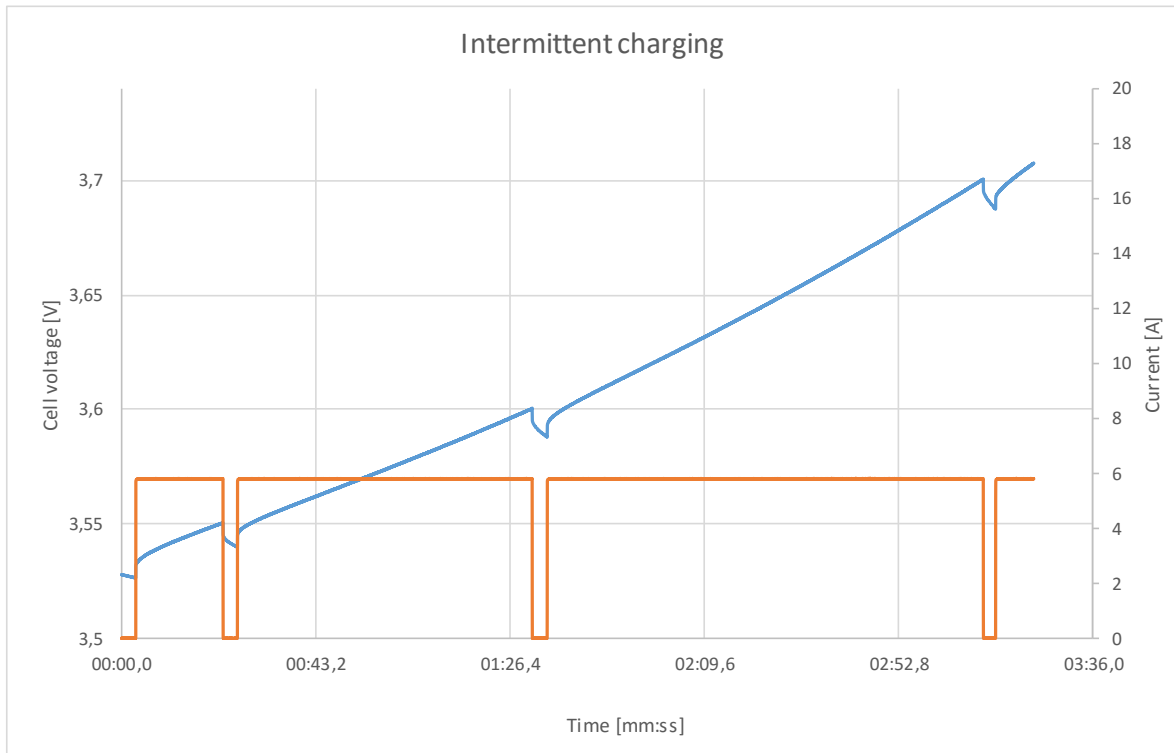

Figure 19: Intermittent charging

The modified Demo circuit DC1696 is used as the Charger. Originally, this demo circuit provided with output characteristic 3,3V and 5A. By replacing some components on this circuit, we achieved output parameters described in Table 10.

Table 10: The Charger characteristic

Max circuit voltage	8,75V
Current	5,7A
Efficiency	88%
Power output	30W

A higher output voltage than it is recommended for charging battery cells is chosen, because it is calculated with loss at the cables. Also, not every battery cell is at the same place. Consequently, the loss will be different for each cell.

Before implementing, the Charger was tested in a way that he charged a battery cell from a fully discharged state to a fully charged state. During charging, the battery cell was charging by stable current and voltage. The charging characteristic is shown in Figure 20.

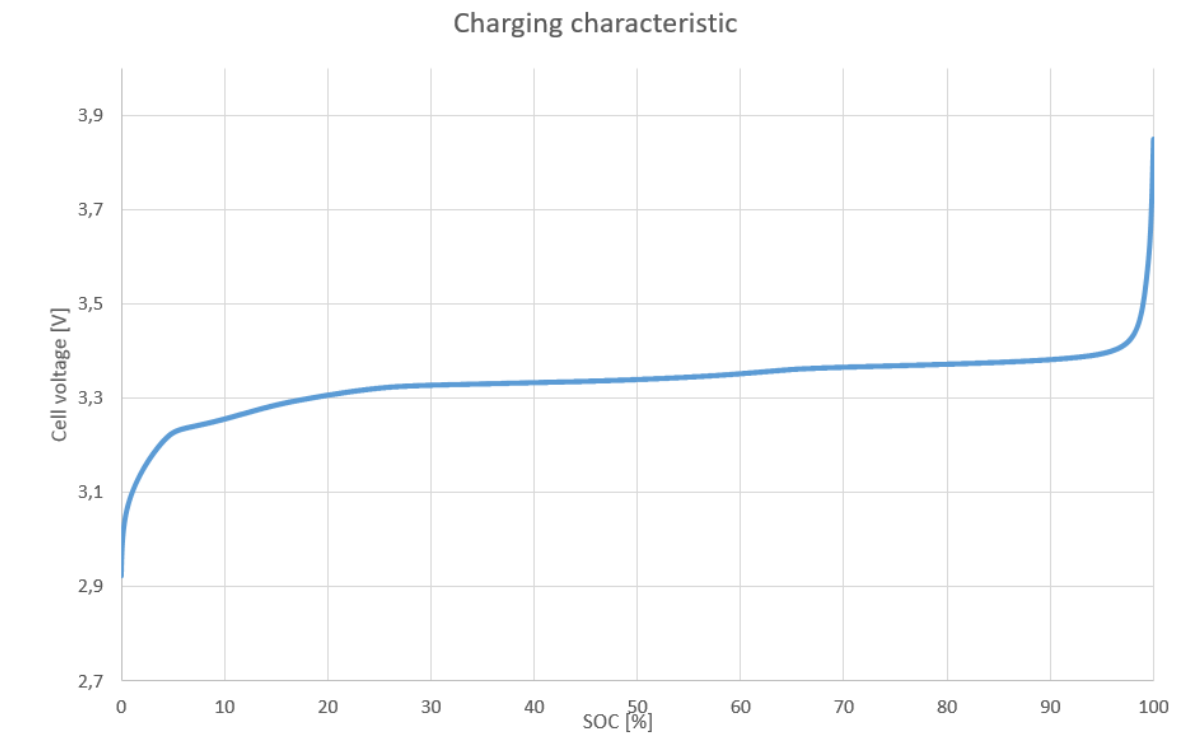
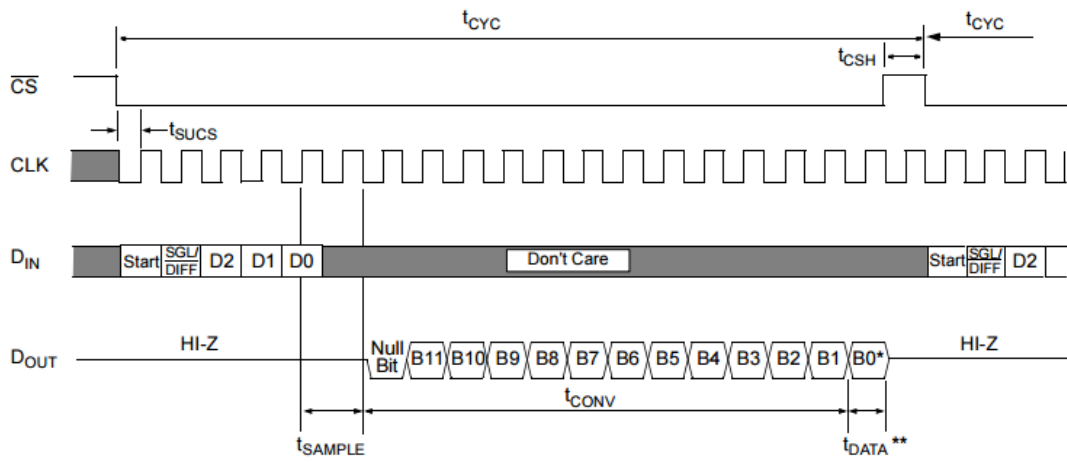

Figure 20: Charging characteristic of the Service board

The data from measurement instruments are translated through 12-bit A/D convertor and sent via SPI communication into the Microprocessor. The SPI communication protocol is shown in Figure 21. The most important bits are D0, D1 and D2, which transfer information about selected channel and mode. The Service board uses comparison mode to measure voltage and absolute mode for current. The comparison mode compares the voltage of ground with the measured value on the battery cells. The absolute mode only measures the value on a single channel input.



* After completing the data transfer, if further clocks are applied with \overline{CS} low, the A/D converter will output LSB first data, followed by zeros indefinitely (see Figure 5-2 below).

** t_{DATA} : during this time, the bias current and the comparator power down while the reference input becomes a high impedance node, leaving the CLK running to clock out the LSB-first data or zeros.

Figure 21: SPI communication (Microchip)

4.7 POWER SUPPLY BLOCK

The power supply block has only one aim and that is to supply all parts on the Service board with stable voltage. It provides 12V, 5V and 3,3V. The Voltage consumption of the components can be found in the Table 11.

Table 11: Voltage supplied parts

Nominal voltage	Supplied parts
12V	<ul style="list-style-type: none"> Charger (Charger block) Charger's relays (Charger block) Charge pump (Relays block) Output relay (Relays block)
5V	<ul style="list-style-type: none"> Microprocessor (Microprocessor block) Multiplexors (Multiplexor block) Shift register + LEDs (Multiplexor block) Logical value convertor (Wi-Fi block) AD converter + ammeter (Charger block) Reference voltage (Charger block)
3,3V	<ul style="list-style-type: none"> Logical value convertor (Wi-Fi block) Wi-Fi module (Wi-Fi block)

The Power supply block is utilized with one galvanic isolated 12V power source and two Step - down voltage regulators providing 5V and 3,3V. The main 12V power source is supplied from BEV's on-board battery. This battery nominal voltage could be from 11V to 14V, depending on the BEV's condition. For this reason, the main 12V power source was chosen with a range of input voltage from 9 to 18V to provide stable 12V during the whole balancing procedure. This source is capable to supply power up to 75W. Nevertheless, the Service board does not take more than 40W (circa 30W is consumed on balancing).

The Charger takes the energy for cell balancing from the main 12V power source, i.e. from the on-board battery itself. That means it is important to ensure that the on-board battery is connected into the electricity site during ongoing service balancing.

5 SOFTWARE SOLUTION

This chapter describes the software side of the Service board. The software for microprocessor was created by using a tool called AVR studio and the software for on-board unit with tools by NI Labview.

5.1 THE SERVICE BOARD ALGORITHM

The Service board is using an endless loop. After the start of the program, the microprocessor runs initialization procedures, such as ports setting, timers setting, communication setting and basic voltage measurement of all cells to determine the SOC. All other functions are called by hardware interrupts. The simplified algorithm is revealed in Figure 22.

After the procedures initialization, the program waits for a control signal from the on-board unit placed in BEV. According to Table 4, the control signal could take form of three different values.

First control signal means to stop any running process, especially the balancing. During this procedure, the microprocessor detaches every relay with the aim to prevent the risk of damage of the battery cells caused by overcharging. The program then waits again in the main loop for the control signals.

Second control signal is for an automatic control. In this mode, the microprocessor decides which cell will be balanced first, second etc., until all cells are fully charged. The process of connecting new battery cell is described in chapter 5.3 Change of battery cell. This process calls also another process, such as the process that starts the balancing or the voltage measurement process (see chapter 5.2 Voltage measurement + AD converter). After everything is set up, the program goes back to the main endless loop and waits until the new control signal comes or the cell is fully charged.

The last of control signals is a mode called manual control. The user can choose the cell which he wants to balance first. The program uses the same procedures as in the automatic mode. After the chosen cell is fully charged, the program switches into the automatic mode to complete the whole balancing process.

User can send the control signal in any moment right after the initializing process has ended. The microprocessor uses the serial communication with interrupts. As a result, the program

is stopped in a specific moment, the control signal is received and new chosen mode can start.

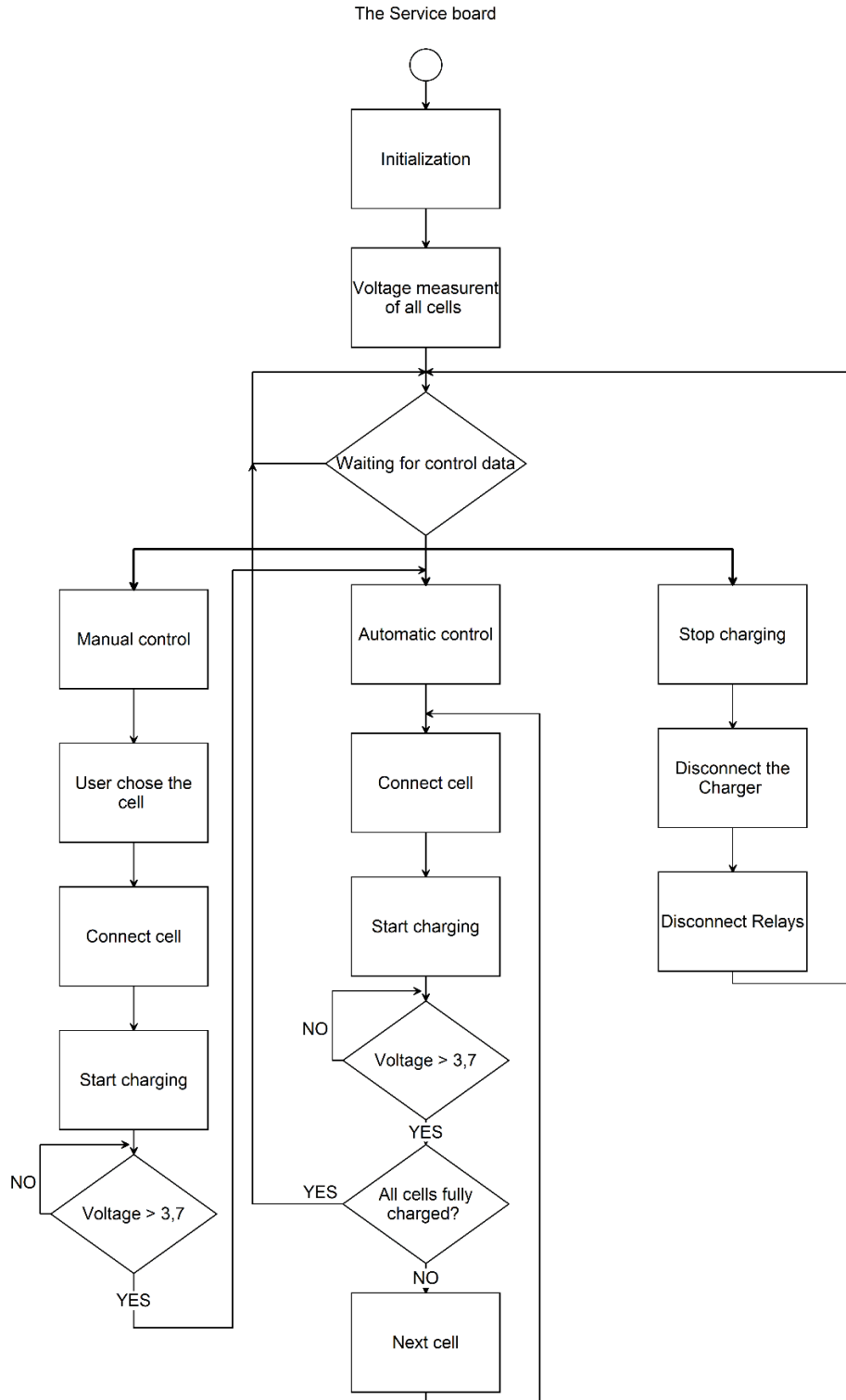

Figure 22: The Service board algorithm

5.2 VOLTAGE MEASUREMENT + AD CONVERTER

The Service board measures cell voltages by two different approaches. As it is implied in Figure 5, during the balancing process, the Charger is connected to the same cables as the AD converter (voltmeter). Consequently, when the Charger is running and in the same time the voltage measurement is required, the obtained value is the voltage on battery and the losses on cables (through which the current flows).

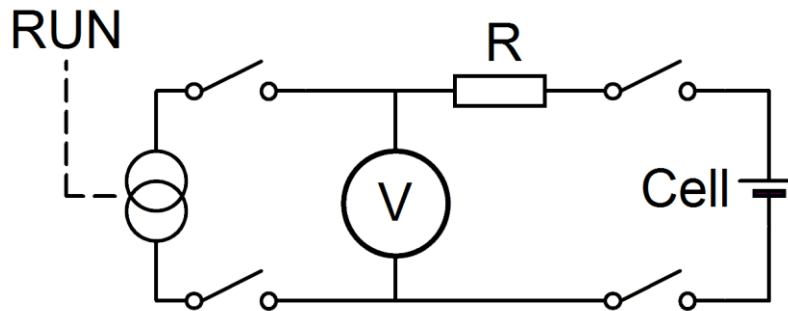

Figure 23: Voltage measurement electrical scheme

Figure 23 indicates that it is necessary to detach the Charger to achieve the voltage measurement without any losses (without the flowing current). That can be reached in two ways. First, by detaching the high voltage relays which takes some time in units of seconds. As is it revealed in Figure 19, the voltage level rapidly decreases during this time and the value may not be accurate enough. Another possibility is to control the Charger by RUN pin right from the microprocessor. It stops the Charger immediately and we can measure the voltage without any losses.

However, it is important for the balancing not to turn off the Charger too frequently as it would prolong the time of balancing. In the other case, when the voltage is measured with small frequency, the Service board does not know about the actual voltage in the moment and an overcharging of the cell can occur. Regarding these facts, the Service board uses two different ways of voltage measurement.

The first way of voltage measurement, which is shown in Figure 24, will be called via interruption every minute. This measurement procedure reads the value of AD converter and obtains information about voltage occurred on cell together with losses on the cables. The procedure then turns the Charger off for a moment and reads values from AD converters again. In that moment, it obtains value without any losses. Therefore, the cable's loss can be

calculated and stored for further purposes. At the end of the procedure, the original state of the Charger is restored.

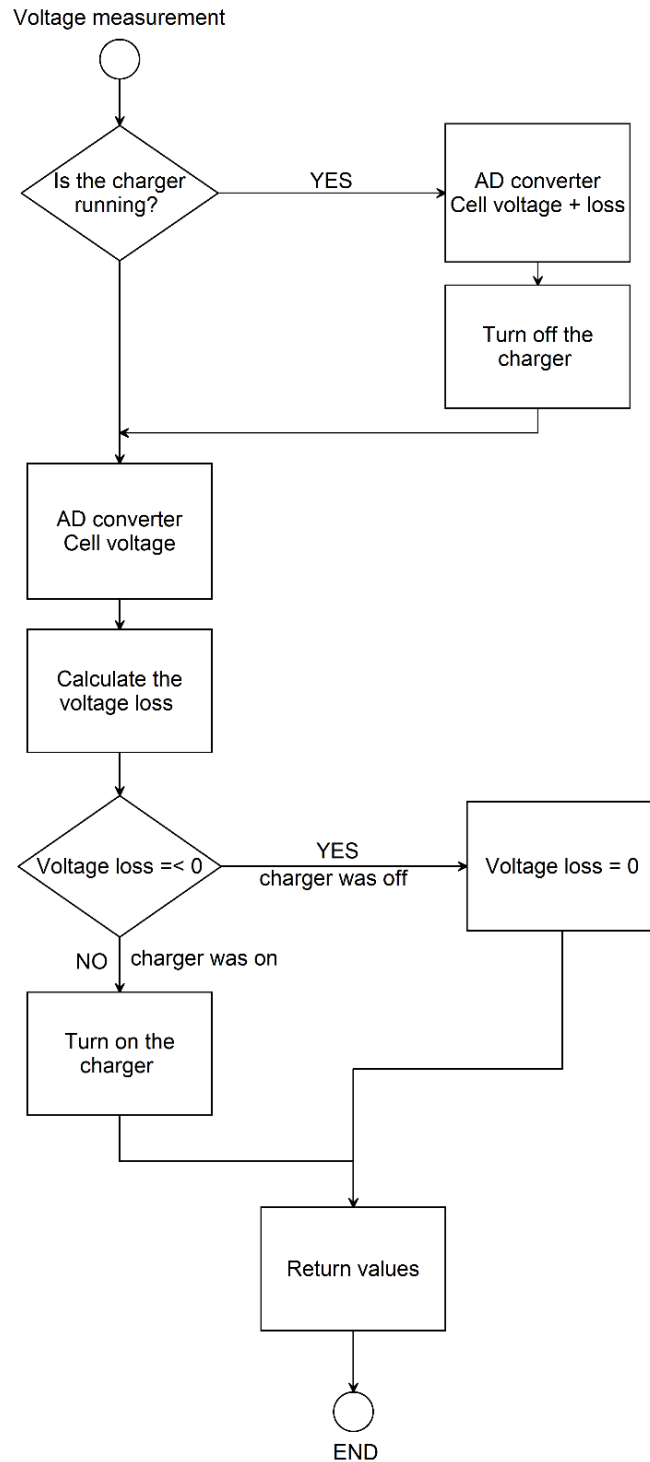

Figure 24: Voltage measurement algorithm

The second type of measurement takes place every second. It is called via timer interruption – the same way as the previous one. This measurement consists of reading the value from AD converter. Since the loss on the cables is already known and updated within specified period, the actual voltage on battery cell can be calculated by formula:

$$V_{cell} = V_{measured} - V_{loss}$$

The accurate and precise measurement can be easily achieved whenever it is necessary. The AD converter is able to transfer the digital data with precision of 12 bits. The voltage reference (voltage range) is 4,08V and the achievable precision is up to 0,001V.

$$V_{\Delta} = \frac{V_{reference}}{2^{12}}$$

To ensure the most precise result, the value is measured ten times and the average value is calculated.

The current measurement has range from -20A to 20A. It uses the same AD converter as in the case of voltage measurement. Therefore, the smallest recognized value is up to 0,01A.

5.3 CHANGE OF BATTERY CELL

When the procedure for changing the battery cell is called, the program tries to disconnect any connected cell first. The next step is to inspect if the cell was really disconnected. If it is, the procedure continues to the next step which is setting the shift registers; otherwise the error state occurs and the program is stopped.

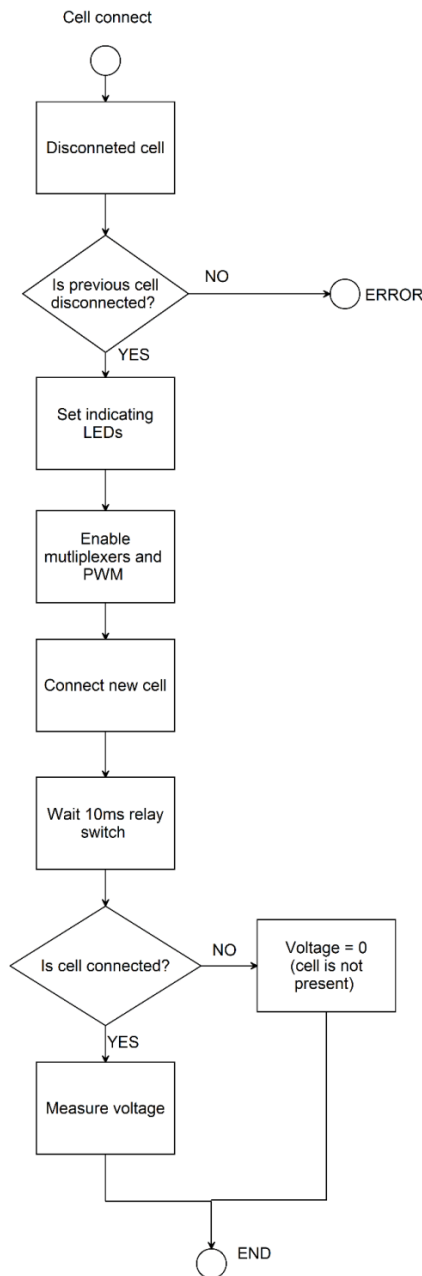

Figure 25: Cell connection algorithm

After the indicating LEDs are set by shift registers (see 5.4 Shift registers control), the microprocessor enables the PWM and sets the multiplexors which will result in the connection of a new cell. The last step of the procedure is an inspection of a proper connection.

5.4 SHIFT REGISTERS CONTROL

This procedure can be called only from the procedure of changing the battery cell. Its purpose to the Service board is to visually show which output is connected and used.

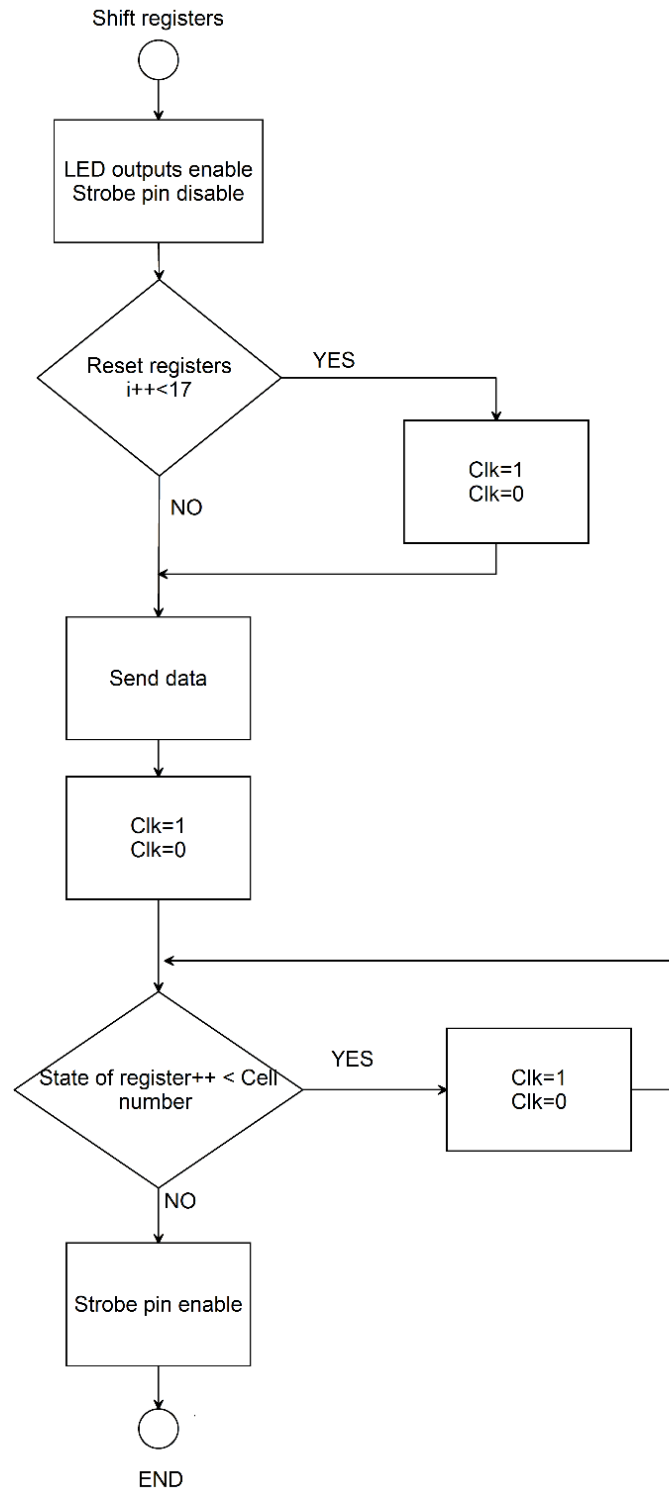

Figure 26: Shift registers algorithm

The shift registers are connected into series; hence the last bit of the first register is used as a first bit for the second register. At the beginning of the procedure, it is necessary to reset the registers to be sure that there is no leftover data from previous usage of the shift registers left. Then, the one single data bit is sent to the first register while the clock is set to one and

back to zero. After that, the clock is set and reset $n-1$ times, where n is the number of a specific cell. This whole procedure is bound by pulling the strobe pin (port PC0) down and up again.

5.5 ON-BOARD UNIT'S PROGRAM

The on-board program disposes of four graphs which show the actual voltage of all battery cells (every graph is intended for four battery cells). The actual value is also shown at the bottom of the program in cylinders represented by battery cells. The program is equipped with a scrolling menu (where the user can choose to which COM port they want to be connected), an LED indicating about the state of charging and buttons STOP and Automatic mode. There is also a possibility to choose a specific cell for balancing, which will result in the manual mode.



Figure 27: On-board control program

6 RESULTS AND DISCUSSION

The current passive balancing system installed in the BEV transforms excess energy from the battery cell into heat. This system is able to manage battery cells balancing with the same conditions (same temperature of surroundings, same age and length of usage, same capacity) in a satisfying way. However, the balancing process of battery cells cannot cope with different conditions. By heating them at high temperature with every single balancing cycle, it can lead to the deepening of differences between cells. In extreme cases, high temperature can lead to either overheating of the battery cells, incineration of the discharge transistor (which controls the balancing function), or simply to leaving the battery cells unbalanced (due to a necessity to cool down the overheated discharge transistor and to turn off the process of balancing). Since the battery cells are quite unbalanced most of the time, the performance, driving distance and battery life of the BEV decrease rapidly. The additional balancing system for maintenance purposes was created while taking into account all the problems mentioned above. The system is called Service board.

The new balancing system has similar core to the active balancing methods, which use active transmission of energy among the battery cells. Nevertheless, the Service board differs in the usage of additional charger as a power source for the balancing and in an individual approach to every battery cell. The disadvantage of the individual approach is that only one cell per time can be balanced – otherwise a shortcut can occur. On the other hand, this is the first system which allows to balance a specific battery cell from the whole chain of battery cells. The Service board is designed for maximum of 16 battery cells. In case there are 42 battery cells, such as inside Citroën Saxo, the Service board has to be used three times to ensure that all cells are equally balanced. The Service board is connected to the battery cells via a special connector, which provides on-board voltage and an access to every cell separately. The individual balancing method uses series connection of the battery cells. Consequently, only $n+1$ cables (where n is a number of the battery cells) are necessary for accessing all battery cells.

Since the Service board is designed as a maintenance balancing system, it should be connected only to already charged BEV. According to the concept, after the connection of the Service board to the BEV, the software measures a state of charge of all battery cells. This information is then sent into an on-board unit, where a human operator can choose the proper reaction. The touchscreen menu, which is a part of the on-board unit, is programmed

in NI Labview environment. It is provided with transparent graphs about the past and present state of the battery cells and several control buttons for choosing the mode of the balancing or for stopping the balancing. The unbalanced battery cells are usually within the range of 3.5V to 3.7V. The time needed to balance one cell from 3.5V to fully charged state is about 3 or 5 minutes per one cell with precision up to 0,002V, which is not achievable with any other conventional balancing system. The human operator does not have to be present during the maintenance balancing. The process of choosing a new battery cell is automatized and the Service board selects the next battery cell automatically.

The hardware design is divided into six blocks according to their functions: the Wi-Fi block, the Microprocessor block, the Relays block, the Charger block and the Power supply block. Since only a prototype was made, the Wi-Fi block stayed unmounted. Instead, the Serial to USB convertor was used to control the Service board. The absence of the Wi-Fi module had no influence on a proper function of the Service board, since the same protocol was used. 8-bit microcontroller ATmega32, programmed to control every function, was used as a heart of the Microprocessor block and the whole Service board as well.

The Relays block provides a physical connection of every battery cell with the Service board. The block is equipped with inspection tools to detect whether the battery cells are properly connected/disconnected and with a safety function called the charged pump, which is frequently used in most safety applications all over the world, such as in nuclear plants. For the purposes of the prototype, only one set of components for one battery cell was mounted. The Charger block offers power source with stable current during balancing. The last block called the Power supply block serves as a galvanic isolator and supplies the whole Service board (including the Charger) with voltage.

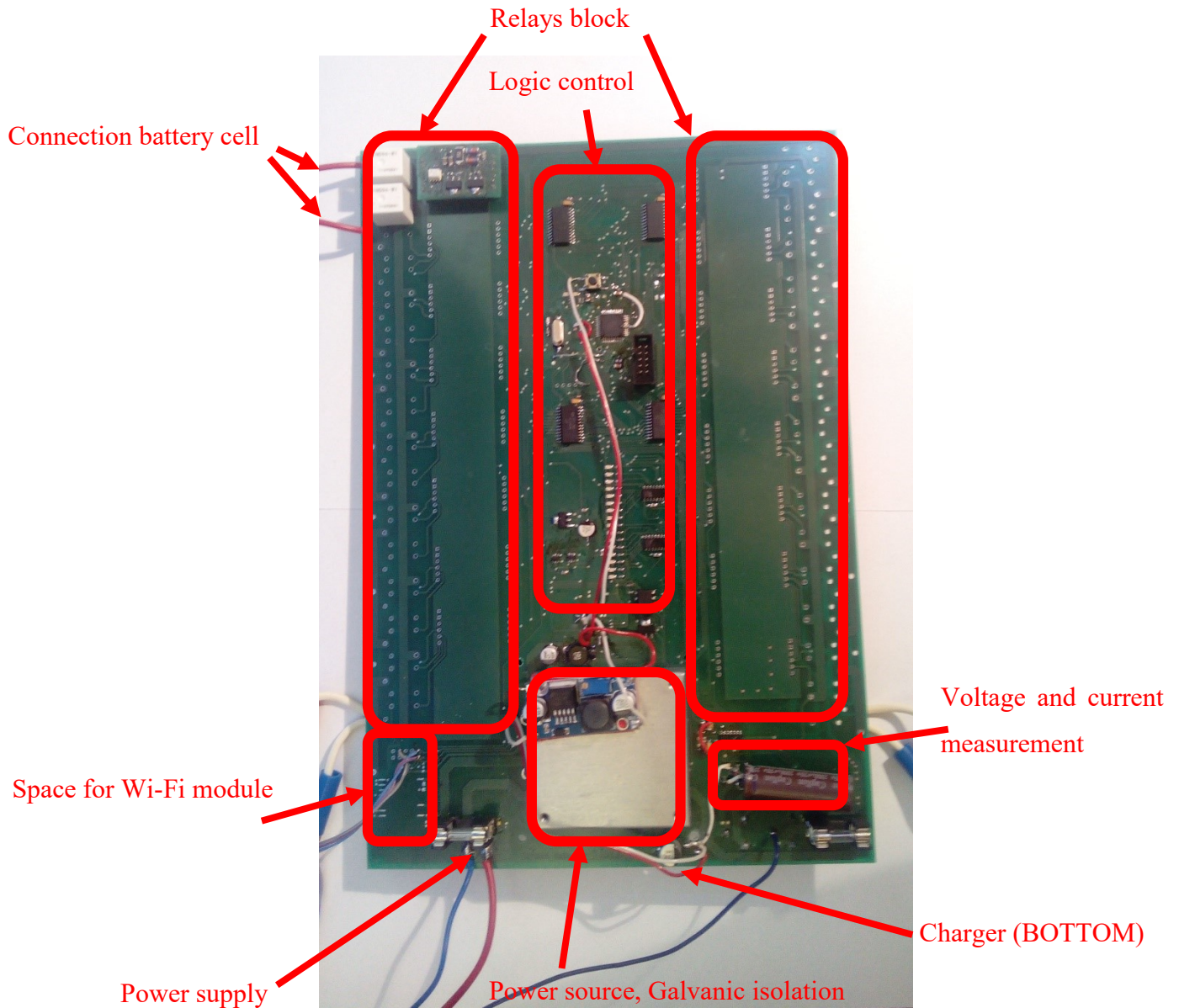

Figure 28: Prototype of the Service board

The Service board is quite a complex and complicated device. The design that the author of this thesis had created was crafted by an external company. With the supervision of doc. Ing. Martin Leso, Ph.D., the author mounted components onto the Service board in the laboratory of the Faculty of Transportation sciences. A few design mistakes occurred during the process of mounting the components. The less important and also the most common errors related to the usage of wrong package dimensions of components. Problems that happened to be more problematic concerned missing connections or insufficient thickness of wires. It led to the substitution of the 5V step-down convertor with an external one. The Charger had to be relocated to the bottom of the Service desk due to inappropriate dimensions. Despite all problems, all hardware components were brought into operation and successfully tested.

The results of the Charger testing can be found in the chapter 4.6 Charger Block. The power supply of the Charger and the whole Service board is from the main 12V on-board battery. For smooth balancing, it is necessary that the BEV's on-board battery is connected into the electricity site. This solution was chosen because of the presence of 12V power supply inside the battery boxes. The Service board could then be easily plugged in to the battery boxes via a connector providing an access to all battery cells and voltage from the on-board battery.

The Service board prototype has not been tested in a real situation yet, it was tested exclusively in the laboratory conditions. The aim of this thesis was not to run the Service board, only to propose its design. To create a prototype was beyond the scope of this thesis. The production of PCBs (one desk of the Service board and 16 charge pumps) cost 3 200Kč, components 5 620Kč (see Appendix M). In total, the price was 8 820Kč without the labour cost.

7 CONCLUSION

The aim of this thesis was to invent a new balancing method of battery cells in a battery electric vehicle (BEV). The utilization of the new balancing method is proposed exclusively for maintenance purposes in the BEVs. This method is primarily designed for BEV Citroën Saxo that is already equipped with a passive balancing system and lithium phosphate battery cells.

The goal was to design the hardware and the software solution for the new, individual balancing method; the outcome is called the Service board. The assignment has been successfully fulfilled. Moreover, the printed circuit board prototype of the Service board was manufactured and mounted by components. The hardware design was made by the Orcad 10.5 tool and crafted by an external company. Components were mounted and tested at the faculty laboratory under supervision. A few errors occurred during the process of components mounting, but they were mainly caused by the complexity of the Service board.

The Service board brings a whole new possibility of extending the battery life, prolonging the driving distance and keeping the BEV performance at high level. It is constructed specifically for the BEV Citroën Saxo. Nonetheless, the system is interoperable with every BEV. The Service board can be used either during a regular state inspection of vehicle or as an addition balancing system. Its original individual approach ensures the highest precision of the balancing process.

8 REFERENCES

- Atmel Corporation. (n.d.). *ATmega16*. Retrieved from Atmel: www.atmel.com/images/doc2466.pdf
- Atmel Corporation. (n.d.). *AVR® JTAG ICE User Guide*. Retrieved from Atmel: <http://www.atmel.com/images/doc2475.pdf>
- Daowd, M., Noshin, O., Bossche, P. V., & Mierlo, J. V. (2011). Passive and active battery balancing comparison based on MATLAB simulation. *Vehicle Power and Propulsion Conference (VPPC), 2011 IEEE* (pp. 1-7). Chicago: IEEE.
- EV-Power.eu. (n.d.). *GWL/Power WB-LYP160AHA LiFeYPO4 (3.2V/160Ah TALL)*. Retrieved from EV-Power.eu - Your Complete Power Solutions: <http://www.ev-power.eu/Winston-40Ah-200Ah/WB-LYP160AHA-LiFeYPO4-3-2V-160Ah.html>
- Glaize, C., & Geniès, S. (2013). *Lithium Batteries and other Electrochemical Storage Systems*. London: ISTE Ltd.
- Kristaps, V. (2014). Redesign of passive balancing battery management system to active balancing with integrated charger converter. *Electronic Conference (BEC), 2014 14th Biennial Baltic* (pp. 241 - 244). Tallinn: IEEE.
- Microchip, T. I. (n.d.). *2.7V 4-Channel/8-Channel 12-Bit A/D Converters*. Retrieved from Microchip: <http://ww1.microchip.com/downloads/en/DeviceDoc/21298c.pdf>
- During writing the thesis, author also benefited from knowledge gained from datasheets to all components (see appendix M) and from following literature:
- LESO, M. and SADIL, J. (6/2013). Analýza a návrh aplikace akumulátorů pro elektromobil. In *Elektro*. P. 6–11.
- MATOUŠEK, D. (2006). *Práce s mikrokontroléry ATMEL AT89C2051: [měření, řízení a regulace pomocí několika jednoduchých přípravků]*. Praha: BEN - technická literatura.
- ZÁHLAVA, V. (2004). *OrCAD 10*. Praha: Grada.

LIST OF APPENDIXES

Appendix A – Charger

Appendix B – Microprocessor

Appendix C – Multiplexer

Appendix D – Power Supply

Appendix E – Relay

Appendix F – Wi-Fi

Appendix G – Servisni_deska_EV_TOP

Appendix H – Servisni_deska_EV_BOT

Appendix I – Drill Chart

Appendix J – Charge pump schematic

Appendix K – Charge pump Left

Appendix L – Charge pump Right

Appendix M – Bill of material

Appendix N – On-board unit software

Appendix O – Software of microprocessor

Appendix A – Charger

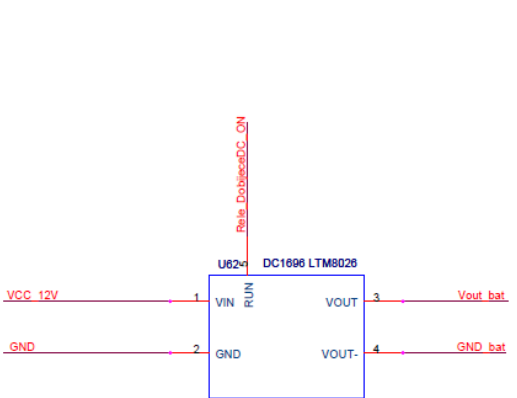
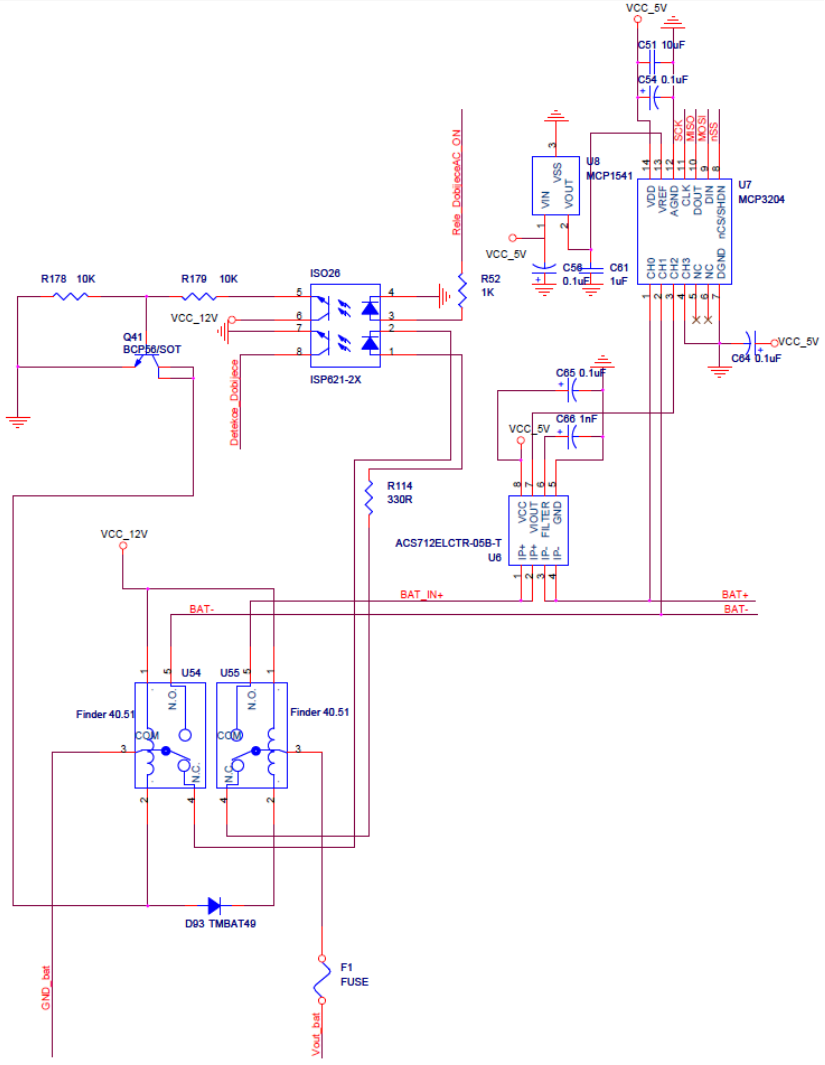

- GND << GND
- VCC_12V << VCC_12V
- VCC_5V << VCC_5V
- VCC_3.3 << VCC_3.3
- BAT+ << BAT+
- BAT- << BAT-
- SCK << SCK
- MISO << MISO
- MOSI << MOSI
- nSS << nSS
- Rele_DobijecDC_ON << Rele_DobijecDC_ON
- Rele_DobijecAC_ON << Rele_DobijecAC_ON
- Detekoe_Dobijec << Detekoe_Dobijec
- NAPAJENI+ << NAPAJENI+
- NAPAJENI- << NAPAJENI-

Appendix B – Microprocessor

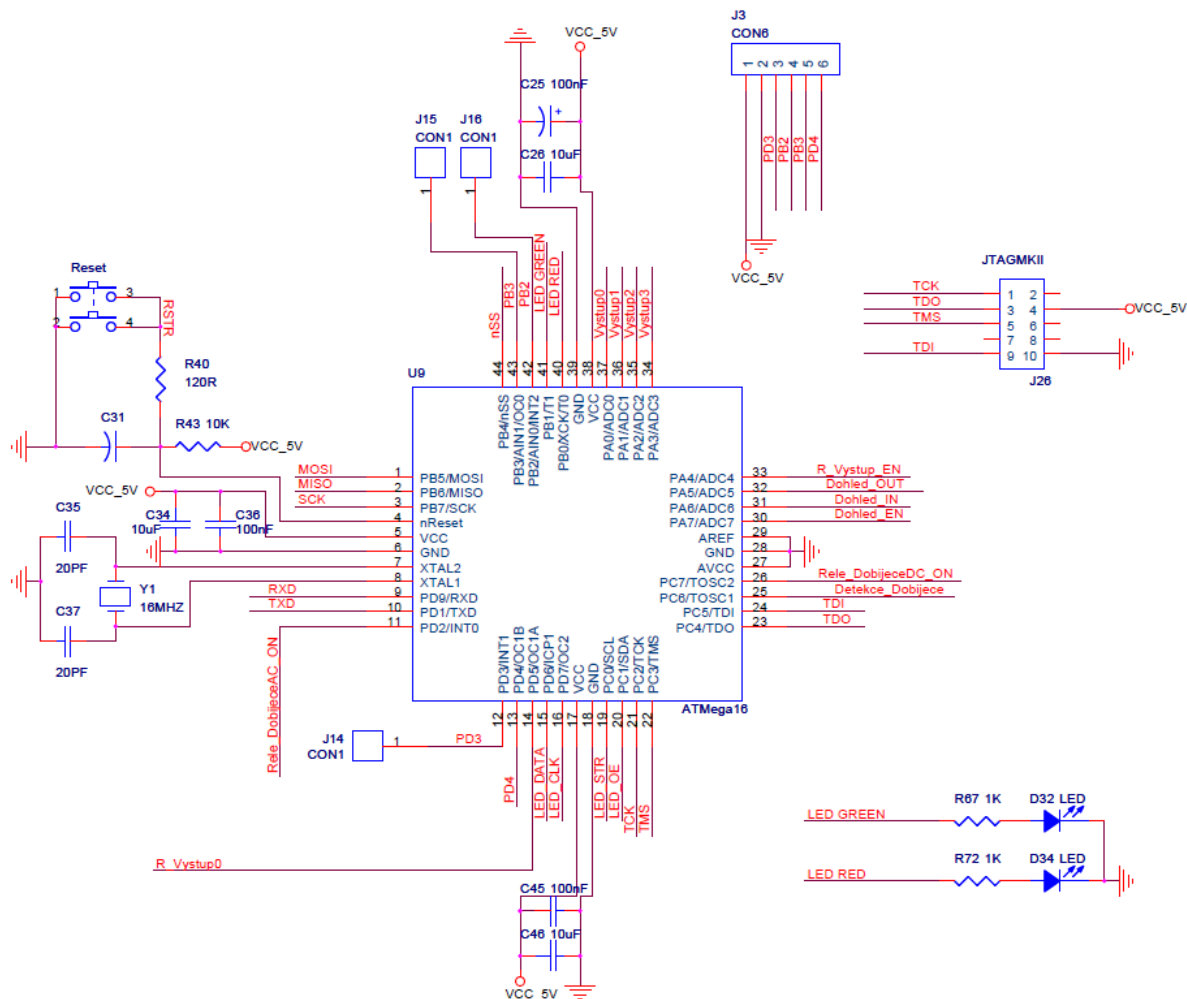

- GND << GND
- VCC_12V << VCC_12V
- VCC_5V << VCC_5V
- VCC_3.3 << VCC_3.3
- SCK << SCK
- MISO << MISO
- MOSI << MOSI
- nSS << nSS
- Vystup0 << Vystup0
- Vystup1 << Vystup1
- Vystup2 << Vystup2
- Vystup3 << Vystup3
- R_Vystup_EN << R_Vystup_EN
- Dohled_OUT << Dohled_OUT
- Dohled_IN << Dohled_IN
- Dohled_EN << Dohled_EN
- LED_OE << LED_OE
- LED_STR << LED_STR
- LED_CLK << LED_CLK
- LED_DATA << LED_DATA
- R_Vystup0 << R_Vystup0
- R_Vystup1 << R_Vystup1
- TXD << TXD
- RXD << RXD
- Rele_DobijeeDC_ON << Rele_DobijeeDC_ON
- Rele_DobijeeAC_ON << Rele_DobijeeAC_ON
- Detekoe_Dobijee << Detekoe_Dobijee
- RSTR << RSTR

Appendix C – Multiplexer

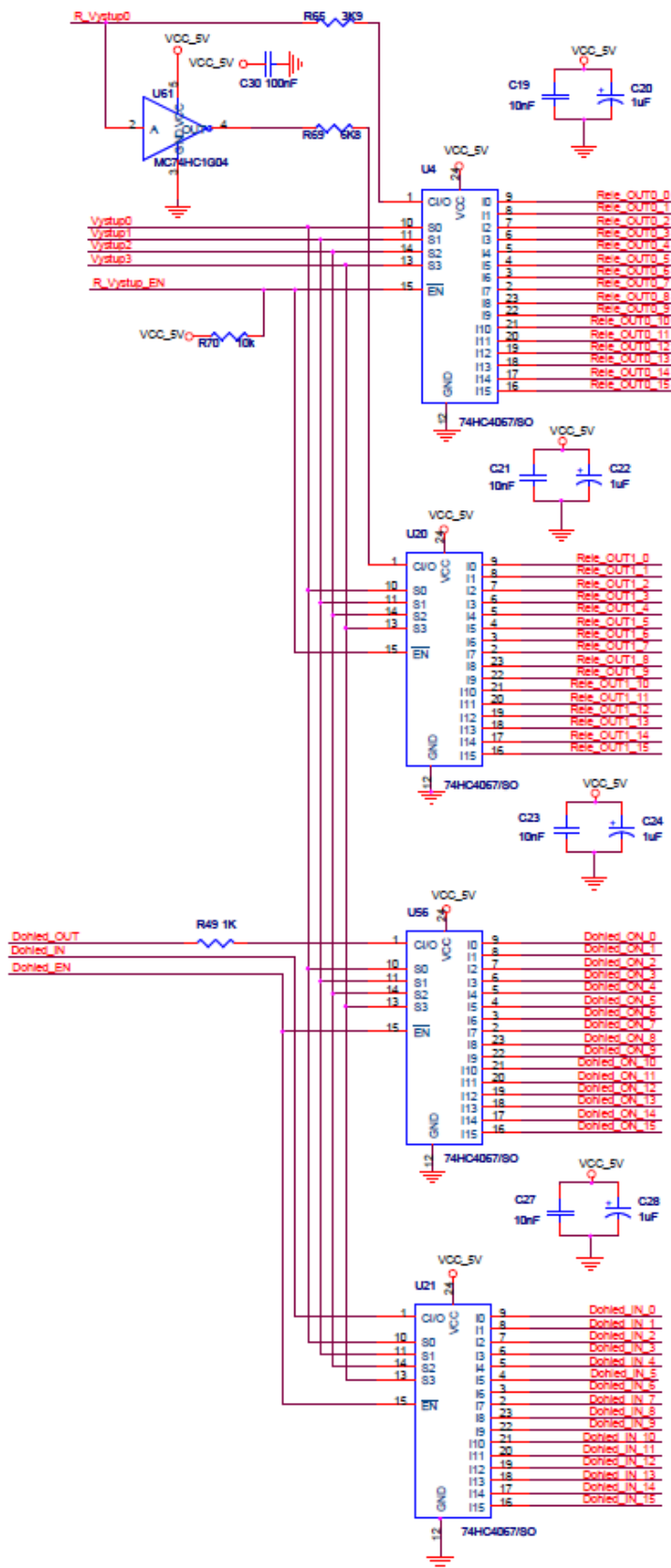

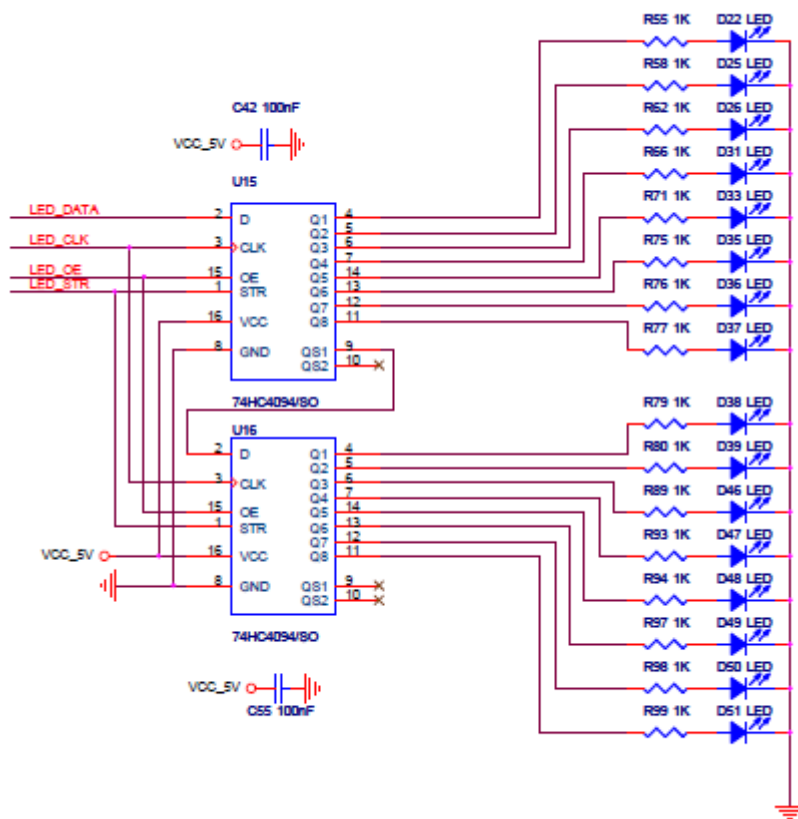

- GND << GND
- VCC_12V << VCC_12V
- VCC_5V << VCC_5V
- VCC_3.3 << VCC_3.3
- R_Vystup0 << R_Vystup1
- R_Vystup0 << R_Vystup0
- Vystup0 << Vystup0
- Vystup1 << Vystup1
- Vystup2 << Vystup2
- Vystup3 << Vystup3
- R_Vystup_EN << R_Vystup_EN
- Dohled_OUT << Dohled_OUT
- Dohled_IN << Dohled_IN
- Dohled_EN << Dohled_EN
- LED_OE << LED_OE
- LED_STR << LED_STR
- LED_CLK << LED_CLK
- LED_DATA << LED_DATA
- Rele_OUT0_0 << Rele_OUT0_0
- Rele_OUT0_1 << Rele_OUT0_1
- Rele_OUT0_2 << Rele_OUT0_2
- Rele_OUT0_3 << Rele_OUT0_3
- Rele_OUT0_4 << Rele_OUT0_4
- Rele_OUT0_5 << Rele_OUT0_5
- Rele_OUT0_6 << Rele_OUT0_6
- Rele_OUT0_7 << Rele_OUT0_7
- Rele_OUT0_8 << Rele_OUT0_8
- Rele_OUT0_9 << Rele_OUT0_9
- Rele_OUT0_10 << Rele_OUT0_10
- Rele_OUT0_11 << Rele_OUT0_11
- Rele_OUT0_12 << Rele_OUT0_12
- Rele_OUT0_13 << Rele_OUT0_13
- Rele_OUT0_14 << Rele_OUT0_14
- Rele_OUT0_15 << Rele_OUT0_15
- Rele_OUT1_0 << Rele_OUT1_0
- Rele_OUT1_1 << Rele_OUT1_1
- Rele_OUT1_2 << Rele_OUT1_2
- Rele_OUT1_3 << Rele_OUT1_3
- Rele_OUT1_4 << Rele_OUT1_4
- Rele_OUT1_5 << Rele_OUT1_5
- Rele_OUT1_6 << Rele_OUT1_6
- Rele_OUT1_7 << Rele_OUT1_7
- Rele_OUT1_8 << Rele_OUT1_8
- Rele_OUT1_9 << Rele_OUT1_9
- Rele_OUT1_10 << Rele_OUT1_10
- Rele_OUT1_11 << Rele_OUT1_11
- Rele_OUT1_12 << Rele_OUT1_12
- Rele_OUT1_13 << Rele_OUT1_13
- Rele_OUT1_14 << Rele_OUT1_14
- Rele_OUT1_15 << Rele_OUT1_15
- Dohled_ON_0 << Dohled_ON_0
- Dohled_ON_1 << Dohled_ON_1
- Dohled_ON_2 << Dohled_ON_2
- Dohled_ON_3 << Dohled_ON_3
- Dohled_ON_4 << Dohled_ON_4
- Dohled_ON_5 << Dohled_ON_5
- Dohled_ON_6 << Dohled_ON_6
- Dohled_ON_7 << Dohled_ON_7
- Dohled_ON_8 << Dohled_ON_8
- Dohled_ON_9 << Dohled_ON_9
- Dohled_ON_10 << Dohled_ON_10
- Dohled_ON_11 << Dohled_ON_11
- Dohled_ON_12 << Dohled_ON_12
- Dohled_ON_13 << Dohled_ON_13
- Dohled_ON_14 << Dohled_ON_14
- Dohled_ON_15 << Dohled_ON_15
- Dohled_IN_0 << Dohled_IN_0
- Dohled_IN_1 << Dohled_IN_1
- Dohled_IN_2 << Dohled_IN_2
- Dohled_IN_3 << Dohled_IN_3
- Dohled_IN_4 << Dohled_IN_4
- Dohled_IN_5 << Dohled_IN_5
- Dohled_IN_6 << Dohled_IN_6
- Dohled_IN_7 << Dohled_IN_7
- Dohled_IN_8 << Dohled_IN_8
- Dohled_IN_9 << Dohled_IN_9
- Dohled_IN_10 << Dohled_IN_10
- Dohled_IN_11 << Dohled_IN_11
- Dohled_IN_12 << Dohled_IN_12
- Dohled_IN_13 << Dohled_IN_13
- Dohled_IN_14 << Dohled_IN_14
- Dohled_IN_15 << Dohled_IN_15

Appendix D – Power Supply

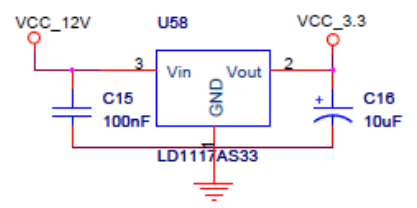
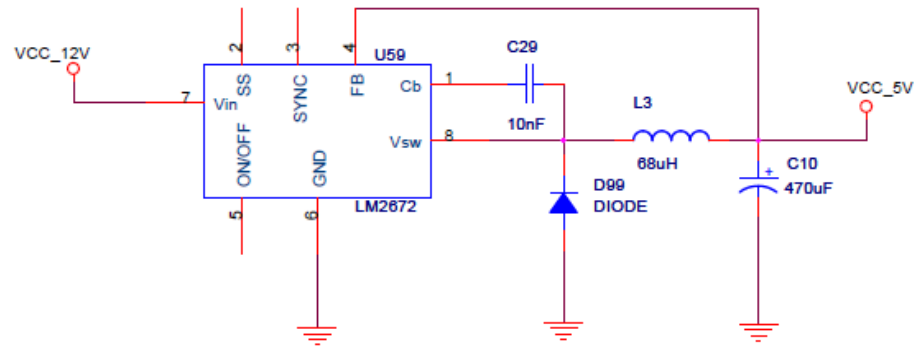
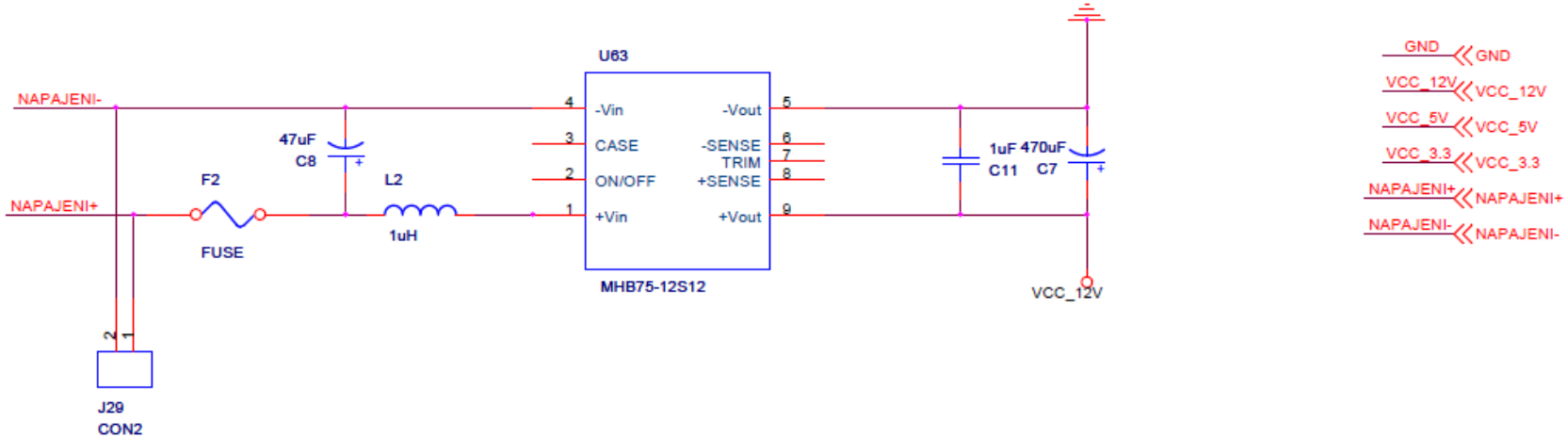

Appendix E – Relay

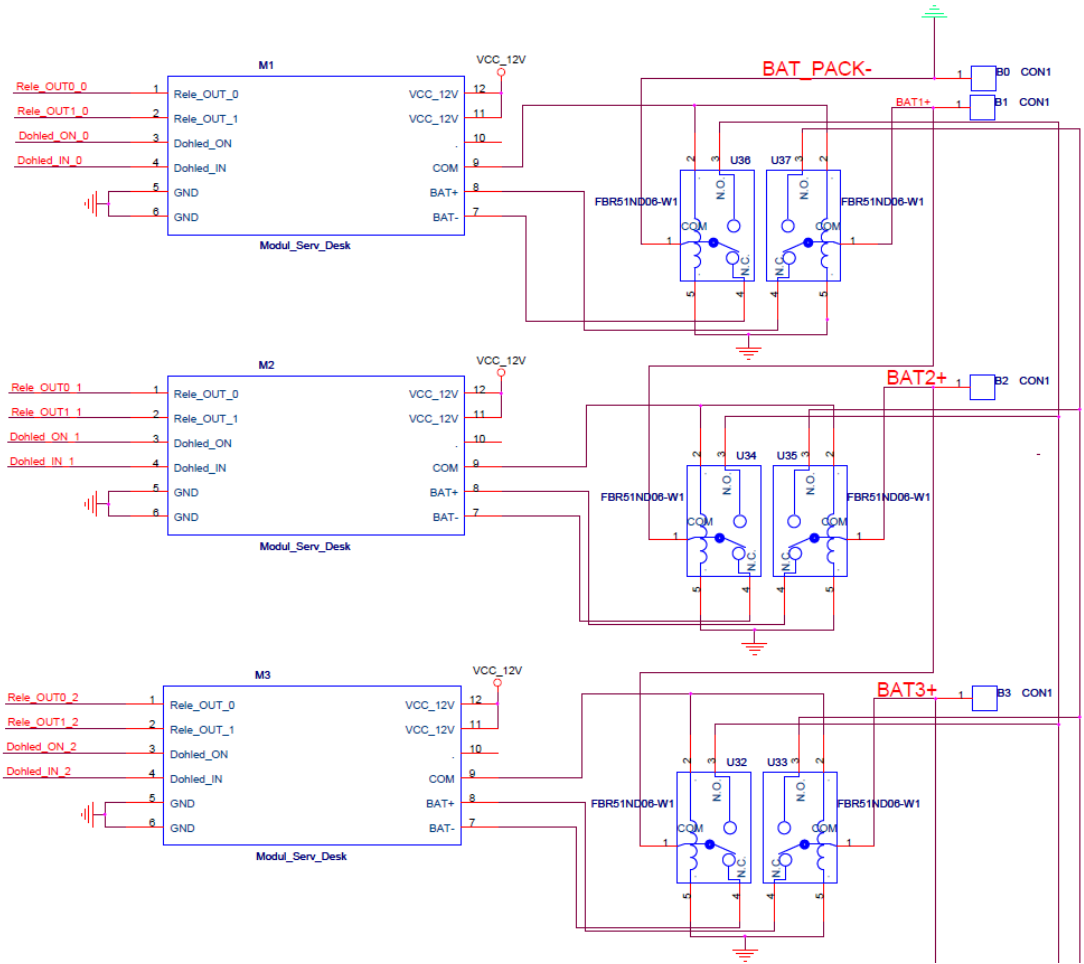

Only first three from sixteen modules.

GND << GND
VCC_12V << VCC_12V
VCC_5V << VCC_5V
VCC_3.3 << VCC_3.3

BAT+ << BAT+
BAT- << BAT-

Rele_OUT0_0 << Rele_OUT0_0
Rele_OUT0_1 << Rele_OUT0_1
Rele_OUT0_2 << Rele_OUT0_2
Rele_OUT0_3 << Rele_OUT0_3
Rele_OUT0_4 << Rele_OUT0_4
Rele_OUT0_5 << Rele_OUT0_5
Rele_OUT0_6 << Rele_OUT0_6
Rele_OUT0_7 << Rele_OUT0_7
Rele_OUT0_8 << Rele_OUT0_8
Rele_OUT0_9 << Rele_OUT0_9
Rele_OUT0_10 << Rele_OUT0_10
Rele_OUT0_11 << Rele_OUT0_11
Rele_OUT0_12 << Rele_OUT0_12
Rele_OUT0_13 << Rele_OUT0_13
Rele_OUT0_14 << Rele_OUT0_14
Rele_OUT0_15 << Rele_OUT0_15

Rele_OUT1_0 << Rele_OUT1_0
Rele_OUT1_1 << Rele_OUT1_1
Rele_OUT1_2 << Rele_OUT1_2
Rele_OUT1_3 << Rele_OUT1_3
Rele_OUT1_4 << Rele_OUT1_4
Rele_OUT1_5 << Rele_OUT1_5
Rele_OUT1_6 << Rele_OUT1_6
Rele_OUT1_7 << Rele_OUT1_7
Rele_OUT1_8 << Rele_OUT1_8
Rele_OUT1_9 << Rele_OUT1_9
Rele_OUT1_10 << Rele_OUT1_10
Rele_OUT1_11 << Rele_OUT1_11
Rele_OUT1_12 << Rele_OUT1_12
Rele_OUT1_13 << Rele_OUT1_13
Rele_OUT1_14 << Rele_OUT1_14
Rele_OUT1_15 << Rele_OUT1_15

Dohled_ON_0 << Dohled_ON_0
Dohled_ON_1 << Dohled_ON_1
Dohled_ON_2 << Dohled_ON_2
Dohled_ON_3 << Dohled_ON_3
Dohled_ON_4 << Dohled_ON_4
Dohled_ON_5 << Dohled_ON_5
Dohled_ON_6 << Dohled_ON_6
Dohled_ON_7 << Dohled_ON_7
Dohled_ON_8 << Dohled_ON_8
Dohled_ON_9 << Dohled_ON_9
Dohled_ON_10 << Dohled_ON_10
Dohled_ON_11 << Dohled_ON_11
Dohled_ON_12 << Dohled_ON_12
Dohled_ON_13 << Dohled_ON_13
Dohled_ON_14 << Dohled_ON_14
Dohled_ON_15 << Dohled_ON_15

Dohled_IN_0 << Dohled_IN_0
Dohled_IN_1 << Dohled_IN_1
Dohled_IN_2 << Dohled_IN_2
Dohled_IN_3 << Dohled_IN_3
Dohled_IN_4 << Dohled_IN_4
Dohled_IN_5 << Dohled_IN_5
Dohled_IN_6 << Dohled_IN_6
Dohled_IN_7 << Dohled_IN_7
Dohled_IN_8 << Dohled_IN_8
Dohled_IN_9 << Dohled_IN_9
Dohled_IN_10 << Dohled_IN_10
Dohled_IN_11 << Dohled_IN_11
Dohled_IN_12 << Dohled_IN_12
Dohled_IN_13 << Dohled_IN_13
Dohled_IN_14 << Dohled_IN_14
Dohled_IN_15 << Dohled_IN_15

Appendix F – Wi-Fi

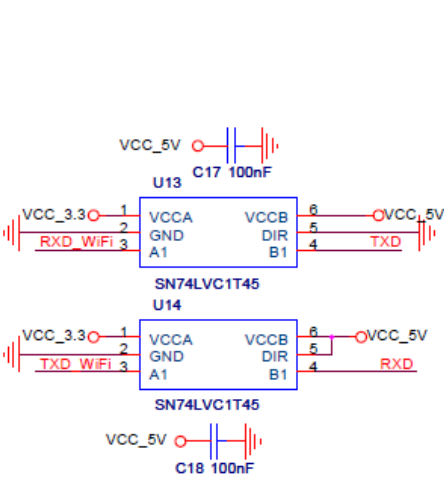

- GND <<< GND
- VCC_12V <<< VCC_12V
- VCC_5V <<< VCC_5V
- VCC_3.3 <<< VCC_3.3
- TXD <<< TXD
- RXD <<< RXD
- RSTR_proc <<< RSTR

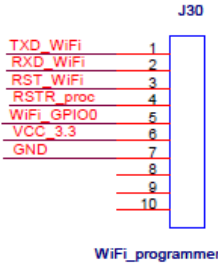
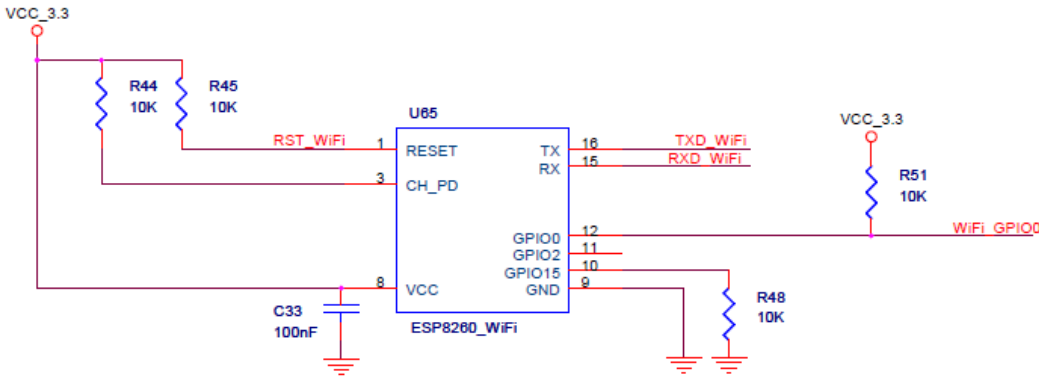

Appendix G – Servisni_deska_EV_TOP

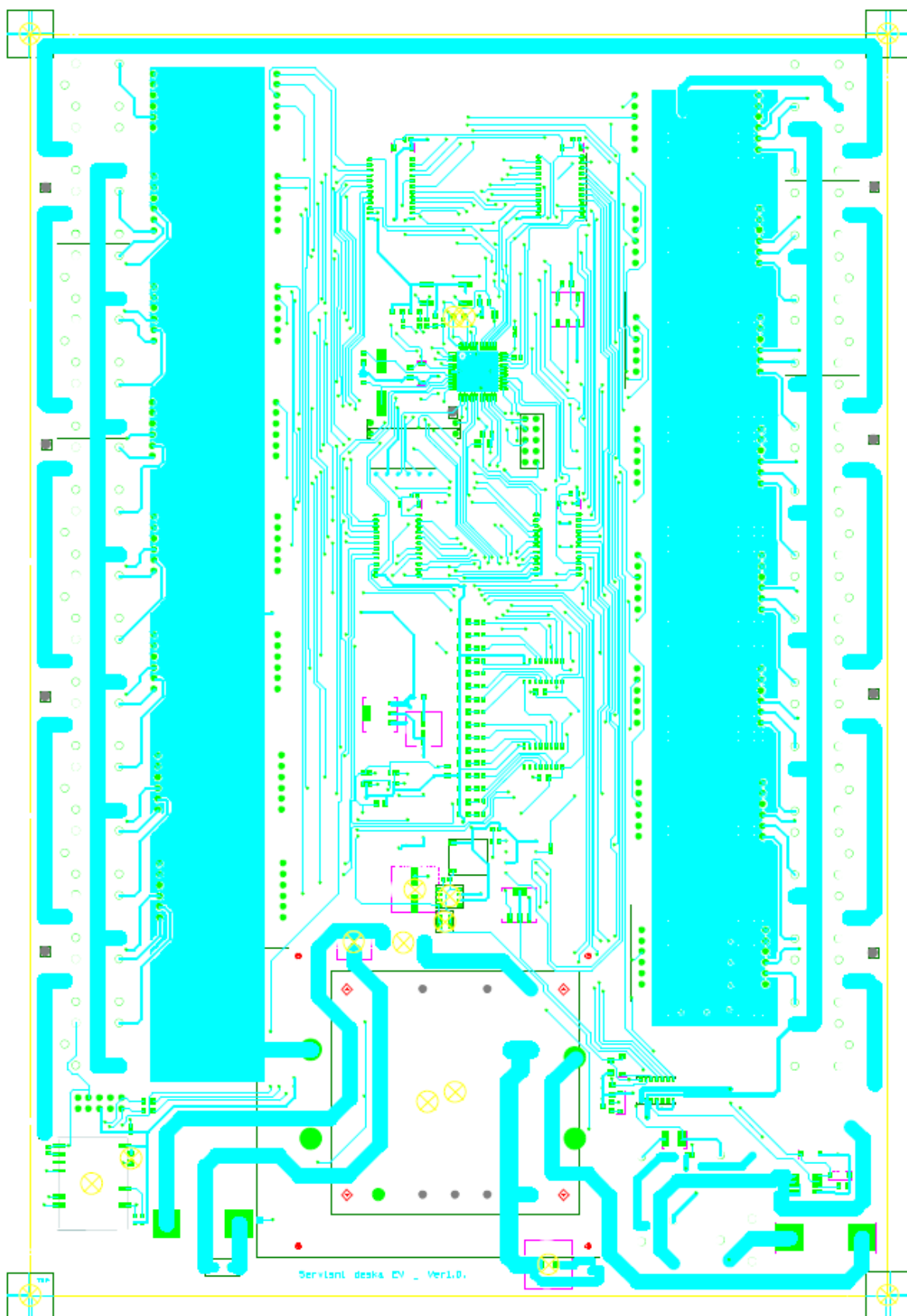

Appendix H – Servisni_deska_EV_BOT

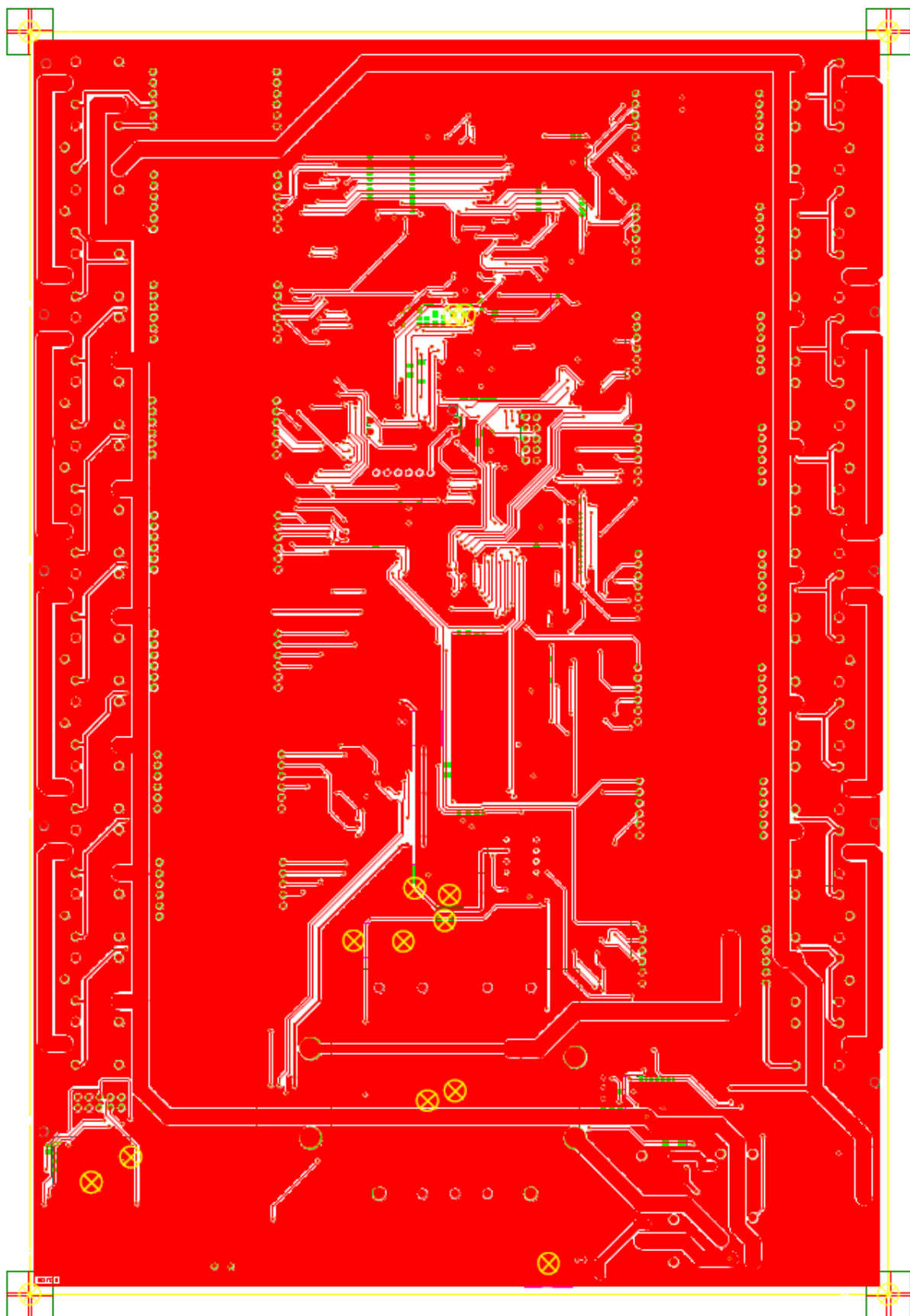

Appendix I – Drill Chart

DRILL CHART				
SYM	DIAM	TOL	QTY	NOTE
○	0.500 mm		480	
+	0.600 mm		8	
⊠	0.900 mm		222	
×	1.100 mm		11	
⊕	1.400 mm		128	
△	1.500 mm		50	
⊗	1.600 mm		10	
+	2.100 mm		2	
⊕	2.500 mm		4	
◇	3.200 mm		4	
×	4.200 mm		4	
TOTAL			923	

Appendix J – Charge pump schematic

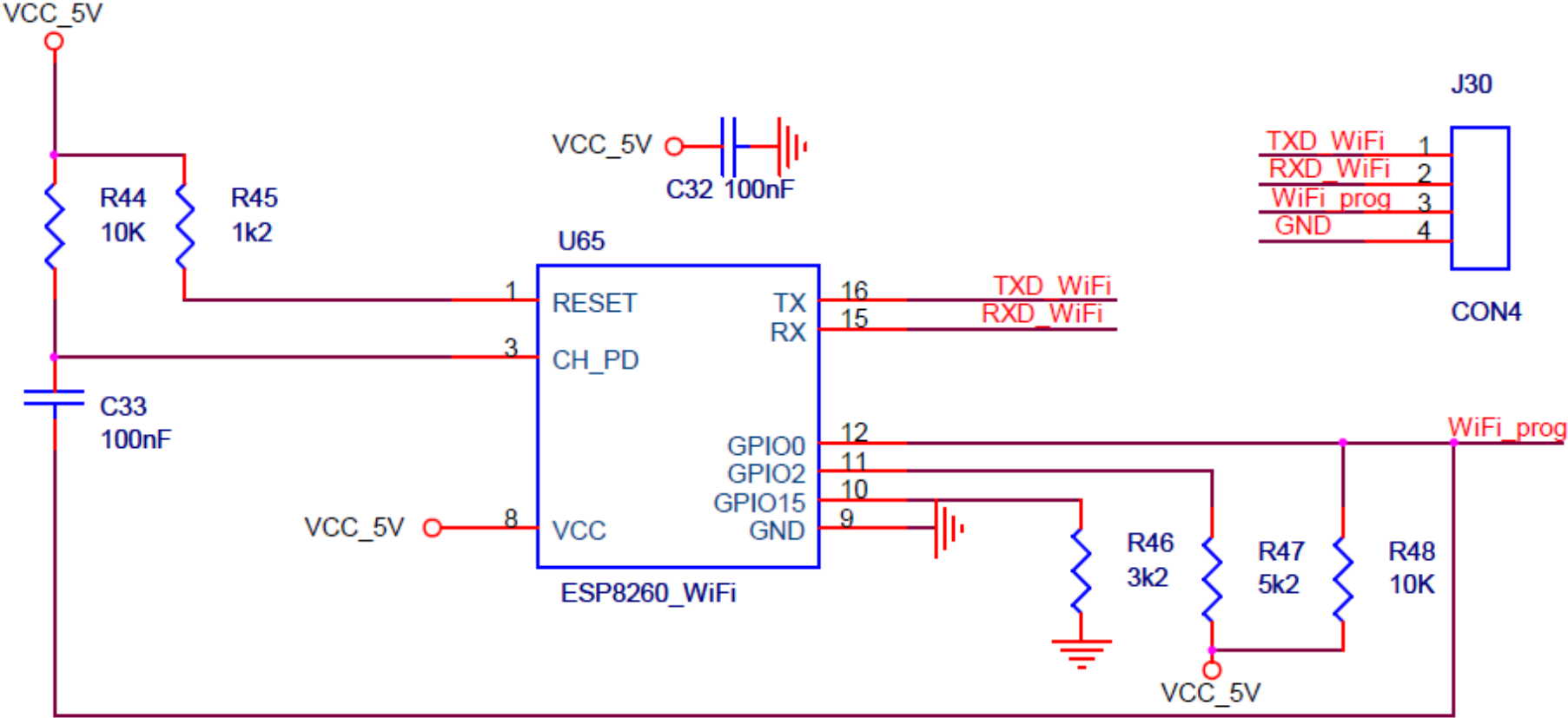

Appendix K – Charge pump Left

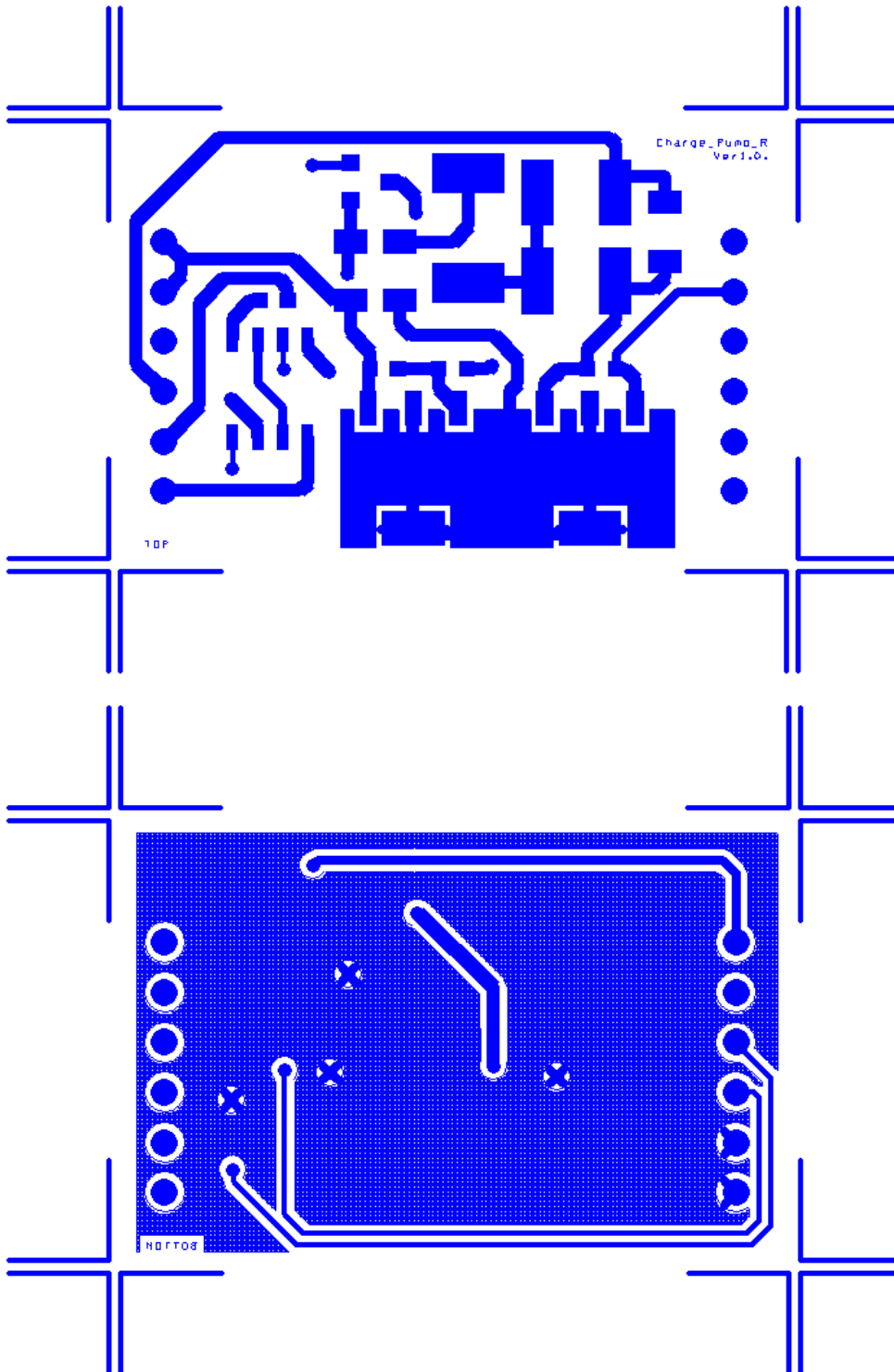

Appendix L – Charge pump Right

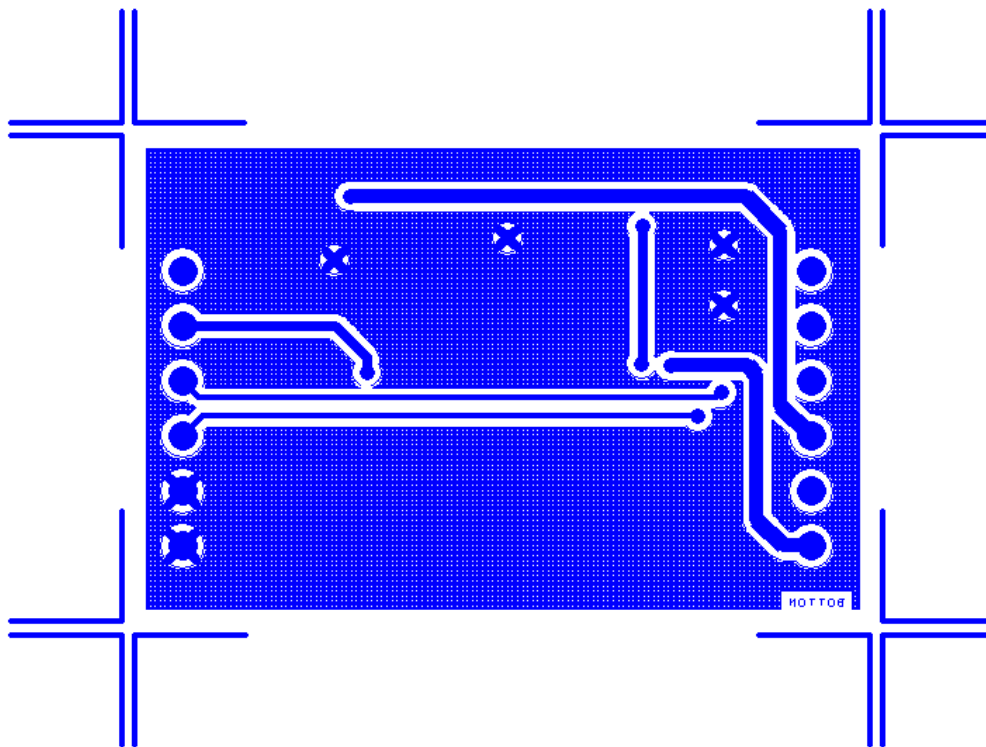
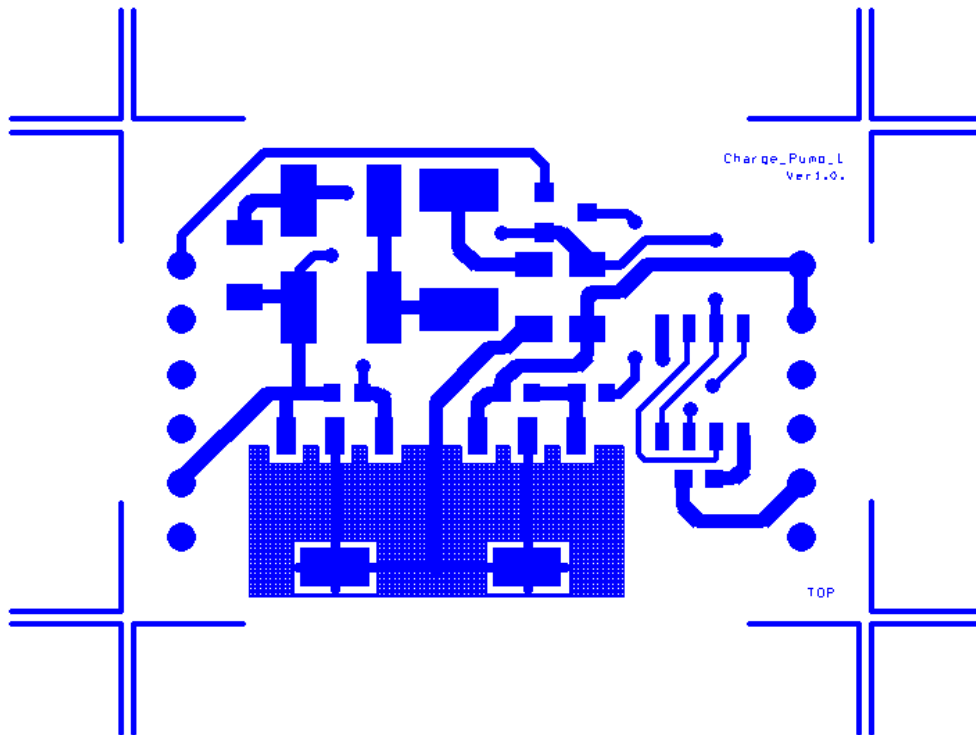

Appendix M – Bill of material

Charge pumps modules

Number of
PBCs: 16

Total price [Kč]
: 863,244

Bill Of Materials April 2,2016 9:00:19

Item	Total quantity	Reference	Part	Catalog number	Price [Kc/part]	Package
1	48	R2,R3,R4	10K	HP03-10K5%	0,185	0603
2	16	R1	330R	HP03-330R5%	0,185	0603
3	16	R5	15R/2W	WF25P150JTL	1,132	2512
4	32	C1,C2	4.7u/50V	12065C475KAT2A	3,445	1206
5	16	C3	1u/50V	12065C105KAZ2A	1,31	1206
6	32	D1,D2	TMBAT49	TMBAT49FILM	7,2	
7	16	Q1	BCV47	BCV47.215	1,615	SOT23
8	16	Q2	BCP53/SOT	BCP53-16.115	2,882	SOT223
9	16	Q3	BCP56/SOT	BCP56-16.115	2,702	SOT223
10	16	U1	Opto 2x _ MOCD207M	MOCD207M	7,56	
11	32	J1,J2	Connector 6x1, 2.54mm	826926-6	5,95	

The Service board

Number of PBCs: 1

Total price [Kč] : 4757,65

Bill Of Materials April 2,2016 9:00:19

Item	Total quantity	Reference	Part	Catalog number	Price [Kc/part]	Package
1	4	C26,C34,C46,C51	10uF	CSMD10U1206X	1,52	1206
2	2	C11,C61	1000nF/25V	08053C105KAZ2A	0,89	0805
4	1	C8	47uF/50V	SC1H476M6L07KVR	1,72	Ø6,3X6,2mm
	1	C66	1nF	SH18B102K500CT	2,24	0603
5	5	C20,C22,C24,C25,C28	1uF	T491A105K020AT	1,87	capacitor_A
6	11	C15,C17,C18,C25,C30,C32 C33,C36,C42,C45,C55	100nF	CC0805JRX7R9BB104	0,161	0805
7	1	C31	4.7u/10V	0805ZC475KAT2A	1,63	0805
8	2	C35,C37	22pF	CL21C220JBANNNC	0,16	0805
9	4	C54,C56,C64,C65	0.1uF	T491A104K035AT	4,439	capacitor_A
11	2	C7,C10	low esr 470uF/16V	EEEFK1C471P	11,04	Ø8X10,2mm
11	1	C16	low esr 10uF	EEEFK1J100P	5,63	Ø6,3X6,2mm
12	5	C19,C21,C23,C27,C29	10nF	CL10B103JB8NNNC	0,129	0603
13	16	D22,D25,D26,D31,D33, D35,D36,D37,D38,D39, D46,D47,D48,D49,D50,D51	LED yellow	HSMY-C170	1,49	0805
14	1	D32	LED green	HSMG-C170	1,49	0805
15	1	D34	LED red	HSMS-C170	1,49	0805
16	1	D93	TMBAT49	TMBAT49FILM	7,2	MELF
17	1	D99	60V/3,5A	30WQ06FNPBF	10,59	T0255AA
18	2	F1, F2	FUSE 10A/250VAC	0034.1526	6,75	5x20mm

19	2	FUSE HOLDER	SHURTER 0031.8221	0031.8221	13,3291	
20	1	ISO26	ISP621-2X	ISP621-2X	9,08	
21	1	J29	CON2			
22	1	J3	CON6			
23	18	J5,J6,J7,J8,J9,J10,J11, J12,J13,J14,J17, J18,J20,J21,J22,J23,J24,J25	CON1			BAT_PAD
24	2	J15,J16	CON1			
25	1	J26	JTAGMKII			
26	1	L2	1uH	DL16-1	7,579	inductance_B
27	1	L3	68uH	DL22-68	17,26	inductance_B
28	1	Q41	BCP56/SOT SW PUSHBUTTON-	BCP56-16.115	3,079	SOT223
29	1	Reset	DPST	B3FS-1050	11,24	B3FS-1050
30	1	R40	120R	HP03-120R	0,319	0603
31	8	R43,R44,R,45,R48,R51,R70,R178,R179	10K	HP03-10K5%	0,185	0603
32	20	R49,R52,R55,R58,R62, R66,R67,R71,R72,R75,R76, R77,R79,R80,R89,R93,R94, R97,R98,R99	1K	HP03W5J0102T5E	0,184	0603
35	1	R65	3K9	PRW05WJP392B00	3,164	THT
36	1	R69	6K8	PMR03SJ0682A19	3,211	THT
37	1	R114	330R	HP03-330R5%	0,185	0603
38	4	U4,U20,U21,U56	74HC4067/SO	74HC4067D	13,38	SO24
39	1	U6	ACS712ELCTR20AT	ACS712ELCTR20AT	92,65	SO8
40	1	U7	MCP3204	MCP3204-CI/SL	76,04	SOIC
41	1	U8	MCP1541	MCP1541T-I/TT	12,08	SOT23
42	1	U9	ATMega16	ATMEGA16L-8AU	170	TQFP44
43	2	U13,U14	SN74LVC1T45	SN74LVC1T45DBVT	16,3	SOT23
44	2	U15,U16	74HC4094/SO 35-75W, 89%,12 V, 6,25A	74HC4094D.652	4,46	SO16
45	1	U63	LM2672-5.0/ 1A	MHB75-12S12	1670	
46	1	U59	LM2672-5.0/ 1A	LM2672 5.0	107,1	
47	32	U22,U23,U24,U25,U26,U27,	FBR51ND06-W1	FBR51ND06-W1	52	---

		U28,U29,U30,U31,U32,U33, U34,U35,U36,U37,U38,U39, U40,U41,U42,U43,U44,U45, U46,U47,U48,U49,U50,U51, U52,U53				
48	1	Y1	16MHZ	16.00M-SMDHC49S	9,587	
49	1	U58	LD1117AS33	LD1117AS33	4,546	SOT223
50	1	U62	Battery charger	DC1696 LTM8026		
51	3	U54,U55	FINDER 50.51	40.51.9.012.0000	42,6	
52	1	U61	7404HC _ NOT	MC74HC1G04DTT1G	1,15	SOT23-5
53	1	U65	WiFi	ESP8266		
54	2	Breaking socket header, double row		CONNFLY DS1021- 2*5SF11		
55	1	Breaking socket header, single row		CONNFLY DS1021- 1*10SF11		

Appendix N – On-board unit software

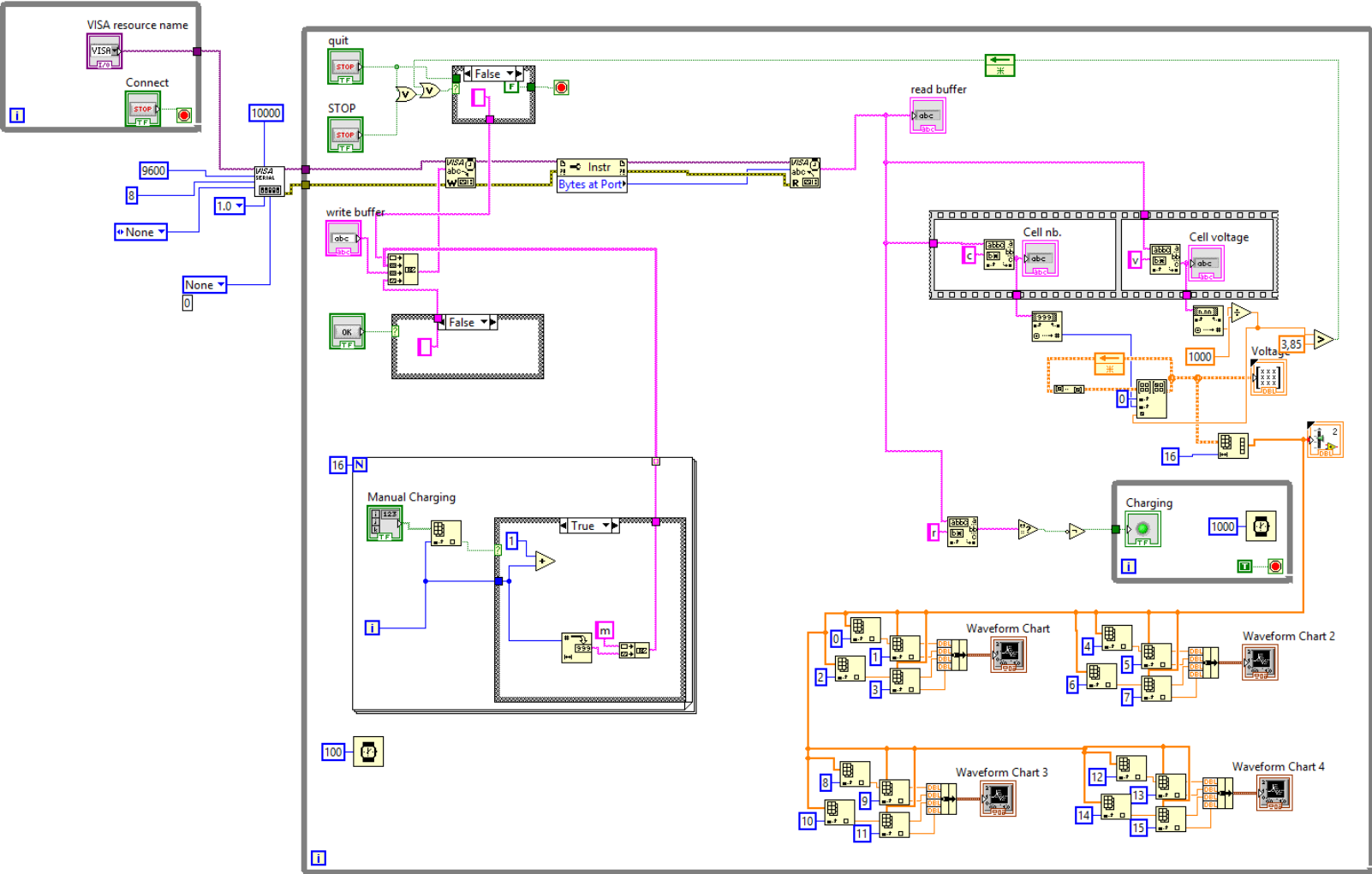

Appendix O – Software of microprocessor

```
#include <avr/io.h>
#include <avr/interrupt.h>
#include <stdio.h>
#include <stdlib.h>
#include <stdio.h>
#include <string.h>
#define F_CPU 16000000UL // -> delay.h)
#include <util/delay.h>
#include <avr/wdt.h> //watchdog
#include <math.h>

#define SetPin(Port, Bit)  Port |= (1 << Bit)
#define ClearPin(Port, Bit)  Port &= ~(1 << Bit)

unsigned int state_shregister=0;

unsigned int error_st=0;

unsigned int change=0;
unsigned int charging=0;
unsigned int charging_counter=0;

int data1=0;
int data2=0;
int data3=0;

float current=0;

float voltage_loss=0;

unsigned int LED_Counter=0;
unsigned long long LED_Counter2=0;
unsigned int LED_Counter3=0;
#define LED_Counter_Period 500

#define max_cell 16
float voltage[max_cell];
int cell_number=0;

volatile unsigned char receivedByte;
volatile unsigned char newByte;

//prototypes
void init();
void timer_init();
void usart_init();
void voltage_measurement(unsigned int cell);
float voltage_avg(void);
void current_avg();
void shift_register(unsigned int cell);
void cell_connect(unsigned int cell);
void error_state();
void automat();
void manual();
void stop();
unsigned char uart_getc(void);
void uart_putc(unsigned char data);
```

```

void USART_creating(char* StringPtr);
unsigned char spi_tranceiver (unsigned char data_SPI);

```

```

////////////////////////////////////
////////////////////////////////////USART INTERUP////////////////////////////////////
ISR(USART_RXC_vect) {
    receivedByte = uart_getc();
    newByte = 1;// new char information
};

////////////////////////////////////
////////////////////////////////////TIMER0 INTERUP////////////////////////////////////
ISR(TIMER0_OVF_vect) {
    TCNT0 = 0x06; //reload counter value

//period 0,5 second

if (LED_Counter++>LED_Counter_Period) {

    if (error_st==0) {
        PORTB ^= 0x02; //GREEN
    }

    else {
        PORTB ^= 0x01; //RED
    };

    LED_Counter=0;
    LED_Counter3++; };

//period 60 seconds
if (LED_Counter2>(60))
{
    voltage_measurement(cell_number); //measure voltage loss
    LED_Counter2=0;
};

//period 1 second
if (LED_Counter3>2)
{
    char str[16];
    uart_putc('c');
    itoa(cell_number, str, 10);
    USART_creating(str);
    uart_putc('v');
    long vol = round(voltage[cell_number]*1000);
    itoa(vol, str, 10);
    USART_creating(str);

    if (charging == 1)
    {
        uart_putc('r');
    };

    LED_Counter2++;
    LED_Counter3=0;
};

```

```

};

/////////////////////////////////////////////////////////////////
/////////////////////////////////////////////////////////////////MAIN PROGRAM/////////////////////////////////////////////////////////////////
int main(void){
  init();

  wdt_reset();// watchdog
  wdt_enable(WDTO_1S);

  //mapping
  for (cell_number=0;cell_number<17;cell_number++) {
    cell_connect(cell_number); };
  PORTA = 0b10010000; //turn off
  ClearPin(PORTC, PC1); //disable LEDs

  while (1) {
    wdt_reset();
    voltage[cell_number]=voltage_avg();

    if (newByte == 1) {
      newByte = 0;
      switch(receivedByte){
        case 's':
          stop(); break;
          case 'a':
            automat(); break;
          case 'm':
            manual(); newByte = 0; break;
        };};

    if (change == 1){
      cell_connect(cell_number);
      change = 0;
      SetPin(PORTC, PC7); //charger
      SetPin(PORTD, PD2); //charger relay
      charging=1;
    };

    if ((voltage[cell_number]) > (voltage_loss + 3.7)) {
      cell_number++;
      change = 1;
      if ((charging_counter++) > 16) {
        stop(); };
      };
    };
  return (0); };

/////////////////////////////////////////////////////////////////
/////////////////////////////////////////////////////////////////INIT/////////////////////////////////////////////////////////////////
void init(void){
  DDRA = 0b10111111;
  PORTA = 0b10010000; //PA5 - outup disable
  DDRB = 0b10110011; //MOSI, SCK
  PORTB = 0b11010000;
  DDRC = 0b10000011; //PC7 CHARGER
  PORTC = 0b01000001; //PC6 pull up, PC1 strobe
  DDRD = 0b11110110;

```

```

PORTD = 0x00;

timer_init();
usart_init();

charging_counter=0;
change=0;
charging=0;

// Initialization SPI
// Enable SPI, Set as Master
// Prescaler: Fosc/16, Enable Interrupts/ MOD3
SPCR=0x5F;

};

////////////////////////////////////
////////////////////////////////////TIMER INIT////////////////////////////////////
//TIMER0 initialize - prescale:64
// WGM: Normal
// desired value: 1KHz
// actual value: 1.000KHz (0.0%)
void timer_init() {
sei();
//TIMER0
TIMSK = 0x01; //Nastavení TOIE0 - povolení interupu counter 1
TCCR0 = 0x00; //stop
TCNT0 = 0x06; //set count
OCR0 = 0xFA; //set compare
TCCR0 = 0x03; //start timer

//TIMER1 PWM 62,5kHz
OCR1A=100;
OCR1B=127;
ICR1H=0;
ICR1L=255;
TCCR1A |= (1<<COM1A1)|(1<<COM1B1)|(1<<COM1B0)|(1<<WGM11);
TCCR1B |= (1<<CS10)|(1<<WGM12)|(1<<WGM13);
};
////////////////////////////////////
////////////////////////////////////USART INIT////////////////////////////////////
//USART 9600Bd, zadna partia, 1stop bit
void usart_init() {
UBRRL = 0x67;
UBRRH = 0b00000000;
UCSRB = 0b10011000; //RXCIE, RXEN, TXEN
UCSRC = 0b10000110; //URSEL write to UCSRC, UCSZ1, UCSZ2 - 8data bit
newByte = 0;
};

////////////////////////////////////
////////////////////////////////////SPI DATA TRANSFER////////////////////////////////////
unsigned char spi_tranceiver (unsigned char data_SPI)
{
SPDR = data_SPI; // Load data into the buffer

while(!(SPSR & (1<<SPIF) )); //Wait until transmission complete
return(SPDR); // Return received data
};

```

```
////////////////////////////////////  
////////////////////////////////////VOLTAGE AVG////////////////////////////////////
```

```
float voltage_avg(void)  
{  
int k=0;  
float voltage_sum=0;  
  
for(k=1;k<11;k++)  
{  
ClearPin(PORTB, PB4);  
data1=spi_tranceiver(0b00000100);  
data2=spi_tranceiver(0b00000000);  
data3=spi_tranceiver(0b00000000);  
SetPin(PORTB, PB4);  
  
data2&=0b00001111;  
  
voltage_sum += ((4.08*(data2+data3))/4096);  
  
};  
voltage_sum = voltage_sum/10;  
  
return (voltage_sum);  
};
```

```
////////////////////////////////////  
////////////////////////////////////CURRENT AVG////////////////////////////////////
```

```
void current_avg() {  
float current_sum=0;  
  
ClearPin(PORTB, PB4);  
data1=spi_tranceiver(0b00000111);  
data2=spi_tranceiver(0b10000000);  
data3=spi_tranceiver(0b00000000);  
SetPin(PORTB, PB4);  
  
data2&=0b00001111;  
  
current_sum = ((4.08*(data2+data3))/4096);  
  
if (current_sum >= 2.5)  
{  
current = (current_sum-2.5)*8;  
}  
else  
{  
current = (2.5 - current_sum)*(-8);  
};  
};
```

```
////////////////////////////////////  
////////////////////////////////////VOLTAGE MEASUREMENT////////////////////////////////////
```

```
void voltage_measurement(unsigned int cell)  
{
```

```

float voltage_charger=0;
int power_state = 0;
int power_state_rele =0;

power_state = PINC;
power_state &= 0b01000000; //mapping, 1=off
power_state_rele = PIND;
power_state_rele &= 0b00000100;

if ((power_state == 0b00000000) && (power_state_rele == 0b00000100))
{ //charger ON
voltage_charger=voltage_avg();
PORTC &= 0b01111111; //Charger OFF
charging=0;
_delay_ms(10);
};

voltage[cell]=voltage_avg();
voltage_loss=voltage_charger-voltage[cell];

if (voltage_loss <= 0) {
voltage_loss=0;
}
else {
PORTC |= 0b10000000; //zapnutí zdroje
charging=1;
};
};

////////////////////////////////////
////////////////////////////////////CELL CONNECTION////////////////////////////////////

void cell_connect(unsigned int cell) {
int dohled_in_state;
int dohled_out_state;

shift_register(cell);
PORTA &= 0b11100000; //outputs disable, disconnect cell
_delay_ms(10); //time relay switch

ClearPin(PORTA, PA7); //inspection enable
SetPin(PORTA, PA5); //inspection ON
dohled_in_state = PINA;
dohled_in_state &= 0b01000000;
ClearPin(PORTA, PA5);
SetPin(PORTA, PA7);

if ((dohled_in_state) != (0b01000000)) //cell did not disconnect
{
//error_state(); //not used in Prototype version - shortcut
voltage[cell]=-1;
}

else
{
PORTA &= 0b11100000; //disconnect cell
PORTA |= cell; //cell selection
ClearPin(PORTA, PA4); //output enable
_delay_ms(10); //time relay switch
}
}

```

```

ClearPin(PORTA, PA7); //inspection enable
SetPin(PORTA, PA5); //inspection ON
dohled_in_state = PINA;
dohled_in_state &= 0b01000000;
ClearPin(PORTA, PA5);
SetPin(PORTA, PA7);
voltage[cell]=voltage_avg();
};

if (dohled_in_state == 0b01000000) //cell did not connect-relay failure
{
    error_state();
};

};
/////////////////////////////////////////////////////////////////
/////////////////////////////////////////////////////////////////SHIFT REGISTER/////////////////////////////////////////////////////////////////
void shift_register(unsigned int cell) {
SetPin(PORTC, PC1); //output enable
ClearPin(PORTC, PC0); //strobe
int i=0;

for(i=state_shregister;i<16;i++)
{ //erasing shift register
SetPin(PORTD, PD7);
ClearPin(PORTD, PD7); //clock
};

SetPin(PORTD, PD6); //send data

SetPin(PORTD, PD7); //clock
ClearPin(PORTD, PD7); //position 0

ClearPin(PORTD, PD6); //no data

for(state_shregister = 0;state_shregister < cell;state_shregister++)
{
SetPin(PORTD, PD7);
ClearPin(PORTD, PD7); //clock
};

SetPin(PORTC, PC0); //end of transmission
};

/////////////////////////////////////////////////////////////////
/////////////////////////////////////////////////////////////////USART/////////////////////////////////////////////////////////////////
unsigned char uart_getc(void)
{
while (!(UCSRA & (1<<RXC)));
return UDR;
};

//Poslani znaku
void uart_putc(unsigned char data)
{
while (!(UCSRA & (1<<UDRE)));
UDR = data;
};

```

```

};

void USART_creating(char* StringPtr){

while(*StringPtr != 0x00){
    uart_putc(*StringPtr);
    StringPtr++;}

}

////////////////////////////////////
////////////////////////////////////CONTROL////////////////////////////////////

void automat()
{
    change = 1;
};

void manual()
{
while (newByte == 0)
{
if (newByte == 1)
    {
        cell_number = receivedByte - '0'; // ASCII code offset
        change=1;
    };
};
return;
};

void stop()
{
change=0;
charging=0;
ClearPin(PORTA, PA4);
init();
};

////////////////////////////////////
////////////////////////////////////ERROR////////////////////////////////////
void error_state() {
error_st=1;
SetPin(PORTA, PA4); //outputs
ClearPin(PORTC, PC7); //charger
ClearPin(PORTD, PD2); //charger relay
charging=0;
};

```