

**CZECH TECHNICAL  
UNIVERSITY  
IN PRAGUE**

**FACULTY  
OF MECHANICAL  
ENGINEERING**



**BACHELOR'S  
THESIS**

**2023**

**AYMAN  
ANAM**

---



# BACHELOR'S THESIS ASSIGNMENT

## I. Personal and study details

Student's name: **Anam Ayman** Personal ID number: **498471**  
Faculty / Institute: **Faculty of Mechanical Engineering**  
Department / Institute: **Department of Energy Engineering**  
Study program: **Theoretical Fundamentals of Mechanical Engineering**

## II. Bachelor's thesis details

Bachelor's thesis title in English:

**High-capacity accumulation of electricity from renewable sources**

Bachelor's thesis title in Czech:

**Vysokokapacitní akumulace elektrické energie z obnovitelných zdrojů**

Guidelines:

- 1) Preparation of a study on renewable sources of electricity and possibilities of electricity storage;
- 2) Development of a balance of electricity production from the selected renewable energy source in correlation with the time dependence of electricity consumption from the grid and a proposal for appropriate electricity storage;
- 3) Evaluation of the feasibility and economic aspects of the proposed storage method.

Bibliography / sources:

Name and workplace of bachelor's thesis supervisor:

**Ing. Matěj Vodička Department of Energy Engineering FME**

Name and workplace of second bachelor's thesis supervisor or consultant:

Date of bachelor's thesis assignment: **17.04.2023** Deadline for bachelor thesis submission: **16.06.2023**

Assignment valid until: **31.12.2024**

Ing. Matěj Vodička  
Supervisor's signature

prof. Ing. Michal Kolovratník, CSc.  
Head of department's signature

doc. Ing. Miroslav Španiel, CSc.  
Dean's signature

## III. Assignment receipt

The student acknowledges that the bachelor's thesis is an individual work. The student must produce his thesis without the assistance of others, with the exception of provided consultations. Within the bachelor's thesis, the author must state the names of consultants and include a list of references.

\_\_\_\_\_  
Date of assignment receipt

\_\_\_\_\_  
Student's signature

## **DECLARATION**

I declare that this thesis is my own work and has not been submitted in any form for another degree or diploma at any university or other institution of tertiary education. Information derived from the published or unpublished work of others has been acknowledged in the text and a list of references given.

In Prague at .....

.....  
Author's signature

## **Annotation sheet**

**Author's name: Ayman Anam**

**Title of thesis: High-capacity accumulation of electricity from renewable sources**

**Academic year: Third year**

**Department: Department of Energy Engineering**

**Supervisor: Matěj Vodička**

<b>Bibliographic data:</b>	Number of pages: 61
	Number of figures: 26
	Number of tables: 11
	Number of appendixes: 0

## **Acknowledgements**

I would like to express my gratitude that everyone who is involved in the development of my Bachelor project, especially my supervisor professor Matěj Vodička, who has assisted and guided me with valuable information during my project. Besides, I would like to thank professors who helped me to get through this academic study program, my friends.

## **Abstract**

In today's conditions where energy supply is increasing day by day, it is unavoidable to turn to sustainable renewable energy sources to meet energy needs. This bachelor's thesis is dedicated to research on renewable energy and high-capacity accumulation of electricity. The first part is about the overall approach to renewable energy sources, the second part is about how can be electrical energy stored and the third part presents a comparison of typical day/annual production characteristics in correlation with the trend of the electricity demand. The final part of the thesis encompasses an in-depth economic evaluation of select accumulation storage systems. This evaluation aims to assess the cost-effectiveness of these systems by scrutinizing their financial performance over their operational lifetimes. The primary objective is to determine whether, within the expected lifespan of the storage system, it can generate adequate revenue to recover the initial investment cost.

## Table of Contents

<b>1. Introduction.....</b>	<b>8</b>
<b>1.1. What is renewable energy? .....</b>	<b>8</b>
<b>1.2. Benefits of Renewable Energy [3].....</b>	<b>10</b>
<b>1.3 Disadvantages of Renewable Energy [3].....</b>	<b>10</b>
<b>2. Wind energy.....</b>	<b>10</b>
<b>2.1. What gives wind its mass?.....</b>	<b>12</b>
<b>2.2. Wind energy characteristics.....</b>	<b>12</b>
2.2.1 Wind power [5].....	12
2.2.2. Air density .....	13
2.2.3. Wind speed .....	14
<b>3. Wind turbines .....</b>	<b>16</b>
<b>3.1. Classification of wind turbines .....</b>	<b>16</b>
3.1.1 Parts: .....	18
<b>Horizontal axis aind turbines (HAWTs).....</b>	<b>19</b>
3.1.2. Wind turbine configuration [5].....	20
<b>3.2 Vertical-axis wind turbines (WAWTs) [4] [5] .....</b>	<b>21</b>
<b>4. Linear momentum theory .....</b>	<b>23</b>
<b>4.1. Energy extraction; Lanchester-Betz-Zhukowsky theory .....</b>	<b>24</b>
<b>4.2. Thrust (axial force) on wind turbines. ....</b>	<b>25</b>
<b>5. Storage technologies .....</b>	<b>27</b>
<b>5.1 Pumped-hydroelectric energy storage (PHES) .....</b>	<b>27</b>
<b>5.2. Compressed air energy storage (CAES) .....</b>	<b>31</b>
<b>5.3 Battery energy storage (BES) .....</b>	<b>33</b>
<b>5.4 Flow battery energy storage (FBES).....</b>	<b>37</b>
<b>5.5 Flywheel energy storage (FES) .....</b>	<b>39</b>
<b>5.5 Hydrogen energy storage system (HESS).....</b>	<b>40</b>
<b>5.6 Other Characteristics of storages .....</b>	<b>43</b>
The Use of Hydrogen Greatly Reduces Pollution .....	45
Risks of leakage and explosions .....	45
Hydrogen can be stored for extended periods without significant degradation. ....	45
<b>6. Electricity balance and demand .....</b>	<b>46</b>
<b>6.1. Electricity production and supply in Denmark from 2000 to 2022.....</b>	<b>46</b>
<b>6.2. Denmark electricity production in 2022 every month.....</b>	<b>47</b>
6.2.1. Denmark electricity production in 2022 every month including the Lead acid battery. ....	49
6.2.2. Denmark electricity production in 2022 every month including the Hydrogen storge. ....	50
<b>6.3. Denmark Electricity Production for one week between 13-19/03/2023 .....</b>	<b>52</b>
<b>7. Economic evaluation.....</b>	<b>54</b>
<b>8. Conclusion.....</b>	<b>57</b>

## List of Tables

Table 1 Different high accumulation storages characteristics (22–26)(27).....	43
Table 2 Advantages and disadvantages of Pumped Storage Hydropower Plants (28).....	43
Table 3 Advantages and Disadvantages of CAES System (29) .....	44
Table 4 Advantages and Disadvantages of Storage Batteries (29).....	44
Table 5 Advantages and Disadvantages of Flywheel (29).....	45
Table 6 Advantages and Disadvantages of Hydrogen energy storage system (30).....	45
Table 7 Data of Table 1 Data of Denmark electricity production in 2022 every month (31) .	48
Table 8 The differences between Wind production and output from the storage and the actual state of charge of the Lead acid battery storage. (31) .....	50
Table 9 The differences between Wind production and output from the storage and the actual state of charge of the Hydrogen storage. (31).....	52
Table 10 Data of Denmark electricity production in the first week of August 2022 (34).....	53
Table 11 Price of electricity every month of the year 2022 (27).....	55

## List of Figures

Figure 1 Types of renewable energy sources [9] .....	9
Figure 2 Idealized atmospheric circulations (4).....	11
Figure 3 Wind speed map of Denmark](6) .....	15
Figure 4 Classification of wind machines and devices: (a) horizontal axis; (b) vertical axis; (c) concentrators.(3).....	17
Figure 5 A horizontal-axis wind turbine configuration. (4).....	20
Figure 6 Several typical types of vertical-axis wind turbines: (a) Darrius; (b) Savonius; (c) Solarwind TM; (d) Helical; (e) Noguchi ; (f) Maglev ; (g) Cochrane (4) .....	21
Figure 7 Lanchester-Betz-Zhukowsky model of the expanding airstream through the turbine rotor, modelled as an actuator disk. (3).....	24
Figure 8 Thrust on wind turbines (3) .....	25
Figure 9 Energy storage technologies. (8) .....	27
Figure 10 Pumped-hydroelectric energy storage (10) .....	28
Figure 11 Wendefurth Pumped-storage Power Plant (11).....	29
Figure 12 Compressed Air Energy Storage (CAES) (12).....	31
Figure 13 Working Compressed Air Energy Storage (CAES)(12) .....	32
Figure 14 LA battery(14).....	34
Figure 15 NiCd battery (15).....	35
Figure 16 Structure of NAS Energy Storage System(16).....	36
Figure 17 Flow battery energy storage (17).....	37
Figure 18 Inside of Flow battery energy storage (18).....	38
Figure 19 Flywheel energy storage(19) .....	39
Figure 20 Hydrogen storage(21) .....	41
Figure 21 Electricity production and supply in Denmark from 2000 to 2022 (31) .....	46
Figure 22 Denmark electricity production in 2022 every month (31) .....	48
Figure 23 Denmark electricity production in 2022 every month including the Lead acid battery (31).....	49
Figure 24 Denmark electricity production in 2022 every month including the Hydrogen storage. (31) .....	51
Figure 25 Denmark electricity production for one week between 1-8/03/2023 (34) .....	53
Figure 26 Price of electricity every month of the year 2022 (27).....	54

# 1. Introduction

In modern power systems, electricity accumulation is critical in overcoming the issues faced by intermittent renewable energy sources and fluctuating electricity demand. As the globe moves toward a cleaner and more sustainable energy landscape, the use of renewable energy sources such as wind and solar power has grown substantially. Renewable energy sources, however, are intrinsically variable and intermittent, depending on factors such as weather and time of day. This fluctuation makes it difficult to maintain a consistent and reliable electrical supply.

The primary purpose of this thesis is to investigate the significance of electricity accumulation and its potential for improving power system stability and efficiency. The purpose of this thesis is to explore and assess several energy storage technologies as possible alternatives for successful power accumulation. The thesis intends to provide insights into the appropriate utilization of energy storage devices for power accumulation by researching their performance, features, and economic viability.

## 1.1. What is renewable energy?

Renewable energy is energy derived from natural sources that are replenished at the same rate than consumed. generated from sources such as the sun and wind that are naturally filled and do not run out. Renewable energy is often used to generate electricity, heat and cool homes and water, and for transportation. Non-renewable energy, specifically, comes from finite sources that may be expended, such as fossil fuels like coal, and oil. (1)



## Types of renewable energy sources:

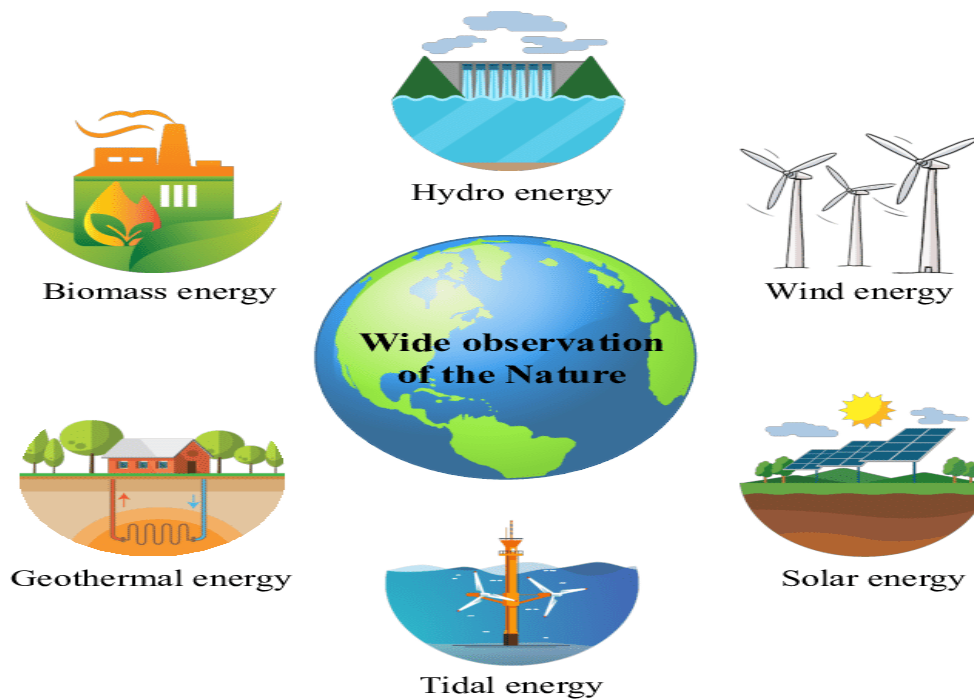

*Figure 1 Types of renewable energy sources (2)*

- 1) Solar energy: The sun's energy turned into electricity and heat energy by solar panels and collectors.
- 2) Wind energy: Kinetic energy of wind converted into electricity using wind turbines.
- 3) Biomass: Energy obtained from plant and animal remains which can be used for example for production of electricity, heat, or alternative products.
- 4) Geothermal energy: Heat energy of the Earth that can be utilized for heat supply or converted into electricity by steam turbines.
- 5) Ocean energy: Oceanic thermal and tidal energy converted into electricity by turbines and other systems.
- 6) Hydropower: Gravitational potential energy of water converted into electrical energy using a hydraulic turbine.

## **1.2. Benefits of Renewable Energy**

1. Renewable energy sources will not run out
2. Reduced carbon emissions and air pollution from energy production
3. Renewable energy could be extracted with limited resources.
4. Renewable technologies create lots of jobs
5. Renewable technologies require less maintenance cost(3)

(3)

## **1.3 Disadvantages of Renewable Energy [3]**

1. Renewable energy is not available round the clock
2. The efficiency of renewable technologies is low
3. The initial cost of renewable energy is high
4. Renewable energy sites require a lot of space

(3)

## **2. Wind energy**

Solar energy produces wind energy as a by-product. On one side (the side facing the sun), the Earth receives heat from the Sun while cooling on the other.

The uneven heating of the Earth atmosphere causes wind movement. Because of the decrease in density, air rises in the heated regions and is replaced by cooler, slightly denser wind, causing movement. Rising hot air is a common and basic occurrence.

Furthermore, because the earth rotates on its own axis, there is a tangential component of wind movement, which gives rise to easterly or westerly wind directions known as trade winds. Wind movements vary locally because of the presence of mountains and other features, such as vegetation or forest cover. Wind speeds generally increase with height, with horizontal components significantly greater than vertical components. Wind speed varies dramatically with time, from seconds to seasons and years, and over distances of 1 km, particularly in hilly terrain. (4)(5)

Another important factor influencing wind direction and speed is the earth's self-rotation. The Coriolis force, produced by the earth's self-rotation, deflects the direction of atmospheric movements. Wind is deflected to the right in the north atmosphere and to the left in the south atmosphere. The Coriolis force varies with latitude; it is zero at the equator and reaches maximum at the poles.

Furthermore, the amount of wind deflection depends on the wind speed; slowly blowing wind is deflected only slightly, whereas stronger wind is deflected more.

The Hadley cell, the Ferrel cell, and the Polar cell are three types of cells. Each cell has its own unique circulation pattern.

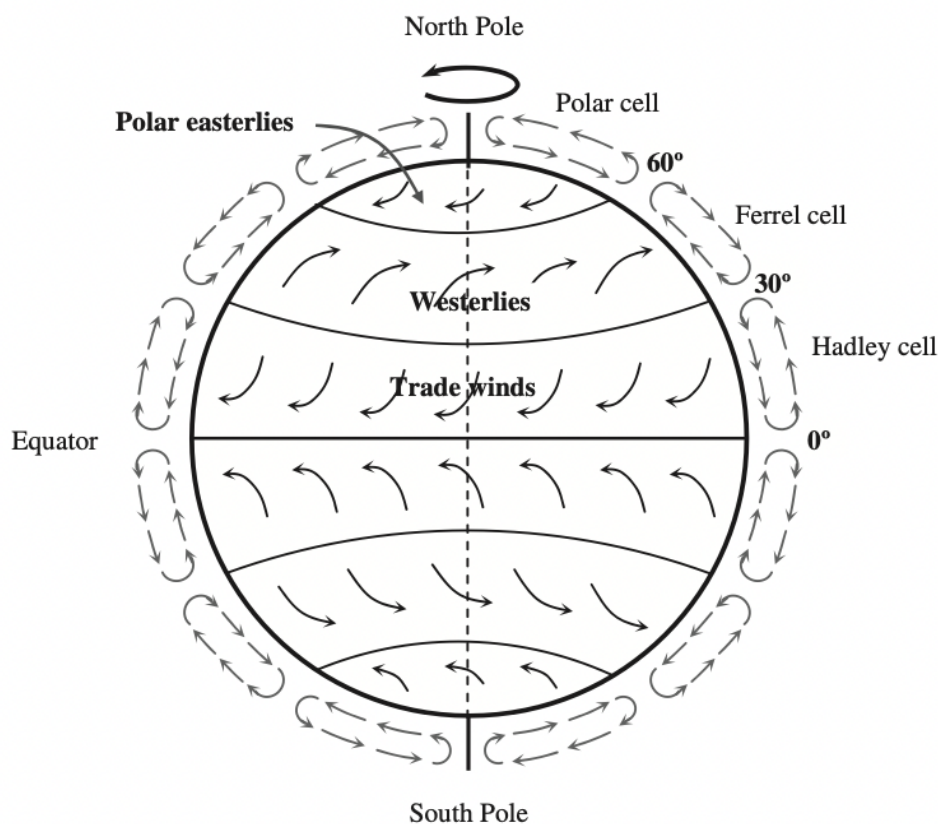

Figure 2 Idealized atmospheric circulations (5)

Between the equator and north latitude 30°, the Hadley cell circulation dominates tropical and subtropical northern hemisphere climates. Hot air rises at the equator and moves northward. The northeast trade winds are caused by Coriolis force. Around north latitude 30°, Coriolis force balances pressure gradient force. West winds have resulted. The air deposited in the upper atmosphere creates the subtropical high-pressure belt and sinks back to the Earth's surface, separating into two parts.

West winds have resulted. The air accumulated in the upper atmosphere forms the subtropical high-pressure belt and sinks back to the Earth's surface, splitting into two components: one returns to the equator to complete the Hadley cell loop, and the other moves toward the North Pole to form the Ferrel cell circulation between north latitude 30° and 60°. At north latitude 60°, the air collides with the North Pole's cold air. Coriolis force deflects air here, creating westerlies. Polar cells circulate between the North Pole and 60° north. The earth's cold air moves from the North Pole to the equator. At 60° north latitude, the Coriolis force pushes airflow southwest. (4)(5)

## 2.1. What gives wind its mass?

Wind is made entirely of air molecules in the atmosphere. The air molecules in the atmosphere include carbon dioxide, oxygen, nitrogen, water vapor, and other gases, all of which are matter and thus have mass-containing atoms. When the density, temperature, and pressure of the atmosphere change, the mass of the atmosphere changes. All these variables have a direct impact on one another. (6)

## 2.2. Wind energy characteristics

Wind energy is a type of kinetic energy that exists in the passage of air. Wind energy can be transformed into electrical energy by power conversion equipment, or it can be utilized directly to pump water, sail ships, or grind grain. (5)

### 2.2.1 Wind power (5)

Kinetic energy exists whenever an object of a given mass moves at a constant translational or rotational speed. When air is in motion, its kinetic energy can be calculated as

$$E_k = \frac{1}{2}mu^2 \quad (1)$$

where  $m$  is the air mass and  $u$  are the average wind speed over a given time. Wind power can be calculated by separating the kinetic energy in wind with respect to time, i.e.

$$P_w = \frac{dE_k}{dt} = \frac{1}{2} \dot{m} u^2 \quad (2)$$

The wind mass flowrate is calculated when wind passes through a wind turbine and causes the blades to rotate.

$$\dot{m} = \rho A u \quad (3)$$

where  $\rho$  is the density of the air and  $A$  is the swept area of the blades. Substituting (3) into (2), the available power in wind  $P_w$  can be expressed as:

$$P_w = \frac{1}{2} \rho A u^3 \quad (4)$$

Because wind power output is proportional to the cube of mean wind speed, a minor change in wind speed can result in a big change in wind power. [5]

### 2.2.2. Air density

One of the key characteristics that has a direct impact on wind power generation is air density, which may be determined using the equation of state:

$$\rho = \frac{P}{RT} \quad (5)$$

where  $\rho$  denotes the local air pressure,  $R$  the gas constant (287 J/kg-K for air), and  $T$  the local air temperature in  $K$ .

According to the hydrostatic equation, when there is no vertical motion, the pressure difference between two heights is created by the mass of the air layer:

$$dp = -\rho g dz \quad (6)$$

where  $g$  is the gravitational acceleration

$$\frac{dp}{p} = -\frac{g}{RT} dz \quad (7)$$

is obtained by combining eqs (5) and (6).

The acceleration of gravity  $g$  decreases with the height above the earth's surface  $z$ :

$$g = g_o(1 - \frac{4z}{D}) \quad (8)$$

where  $g_o$  is the acceleration of gravity at the earth's surface and  $D$  is the earth's diameter. However, because  $D$  is substantially larger than  $4z$ , the fluctuation in height can be ignored for the acceleration of gravity  $g$ .

Furthermore, temperature is inversely proportionate to height. Assuming  $dT/dz = c$ , we can deduce that

$$p = p_o(\frac{T}{T_o})^{-g/cR} \quad (9)$$

where  $p_o$  and  $T_o$  are the ground air pressure and temperature, respectively.

Combining equations (6) and (9), we get

$$\rho = \rho_o(\frac{T}{T_o})^{-g/cR} = \rho_o(1 + \frac{cz}{T_o})^{-(g/cR+1)} \quad (10)$$

This equation shows that the density of air drops nonlinearly as one rises above sea level.

### 2.2.3. Wind speed

Wind speed is one of the most important factors in wind power generating. In truth, wind speed fluctuates throughout time and space, depending on a variety of factors such as geography and weather. Because wind speed is a random parameter, observed wind speed data is usually analysed statistically. (4)(5)

Sine waves are frequently used to describe the diurnal fluctuations in average wind speeds. One of the wind characteristics is wind direction. Statistical data of wind directions collected over a long period of time is critical in wind farm site selection and wind turbine layout. The 'length' or 'run' of the wind passing a 10 m high cup anemometer in 10 minutes is a common meteorological measurement of wind speed. Such measurements can be done hourly, but they are normally taken less frequently. Such statistics provide little information on variations in wind speed and direction, which are required for effectively predicting wind turbine performance. (4)(5)

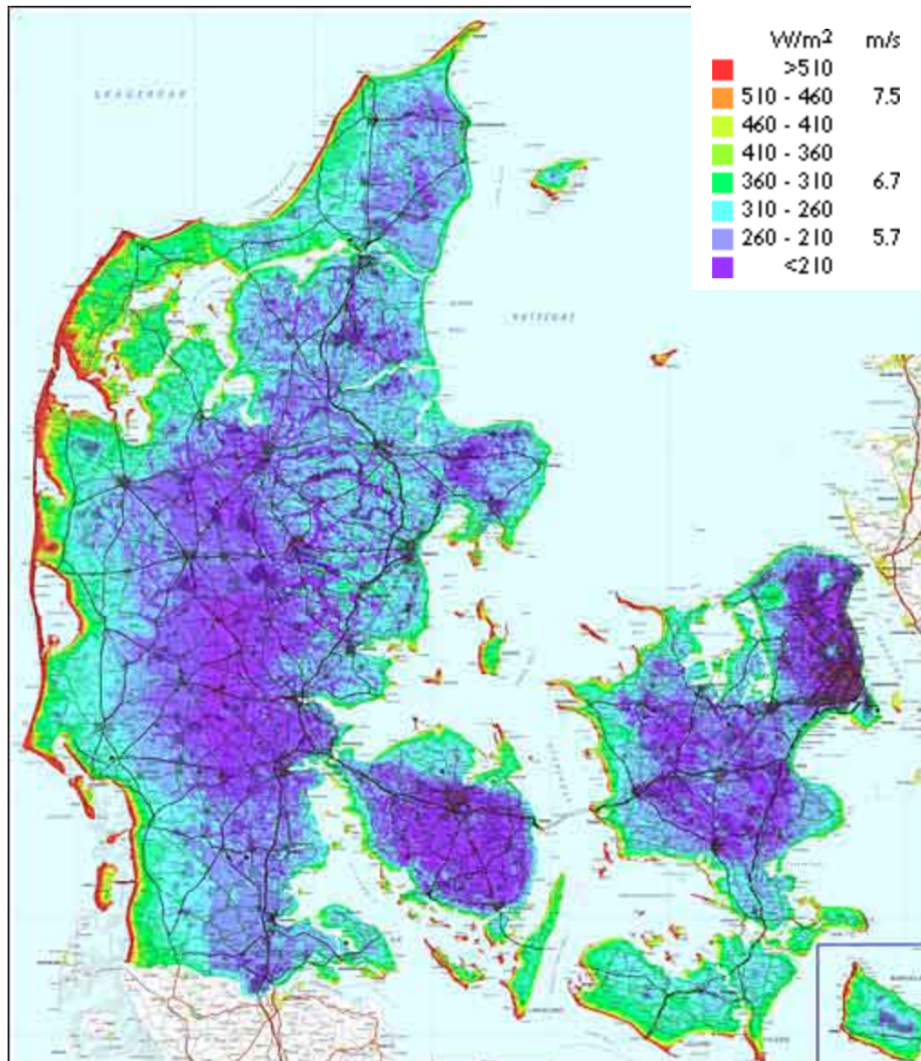

*Figure 3 Wind speed map of Denmark](7)*

This map of Danish wind speeds considers local geography (speed-up effects) and roughness. We can easily observe that the prevailing wind direction in Denmark is west and southwest since west and southwest facing coastal sites have by far the highest energy component of the wind (the red and yellow areas).

Denmark has comparatively low average wind speeds of 4.9-5.6 m/s measured at a height of 10 m. Onshore wind resources are greatest in the western half of the country and on eastern islands with south or west facing coasts. (7)

## 3. Wind turbines

A modern wind turbine is an energy-converting equipment that converts wind kinetic energy into mechanical energy, which is then converted into electrical energy. Wind turbine design has come a long way in the last three decades, thanks to modern technical advancements.

Advances in aerodynamics, structural dynamics, and micrometeorology are expected to lead to a 5% annual increase in wind turbine energy yield. (4)(5)

Various wind turbine concepts have been created and built-in order to maximize wind energy output, reduce turbine costs, and improve turbine efficiency and durability.

### 3.1. Classification of wind turbines

Wind turbines are categorised based on their turbine generator configuration, airflow route relative to the turbine rotor, turbine capacity, generator-driving pattern, power supply method, and turbine installation site. (4)(5)

Figure 4 displays a horizontal axis wind turbine blade section; the same characteristics apply to vertical axis turbines. The segment rotates at  $u_0$  perpendicular to the wind. Due to its movement, the blade section encounters air at relative velocity  $v_r$ .

When the blade disturbs air, two forces act: The dragging force  $F_D$  represents relative velocity  $v_r$ . Lift force  $F_L$  perpendicular to  $F_D$ .  $F_L$  doesn't always go up and come from an airplane wing's comparable force.

These are typically wind turbines with a few blades each. The fastest wind aerogenerators have fewer blades, contrary to popular belief. It is technically conceivable to create a windmill with only one blade. For weight distribution balance, a single-bladed windmill needs a counterbalance on the other end. Most wind aerogenerators generate energy using two, three, or four blades (4)(5)



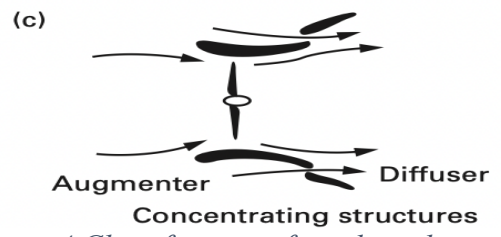
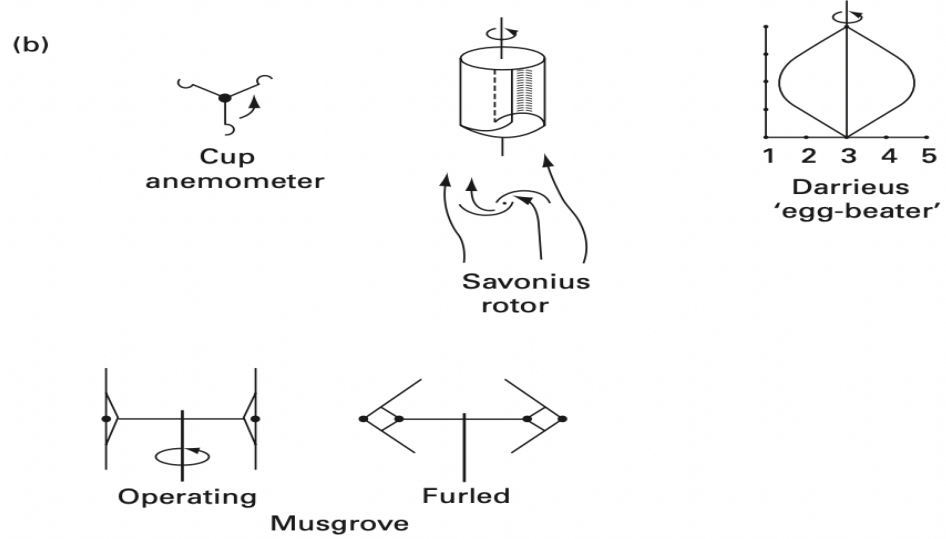
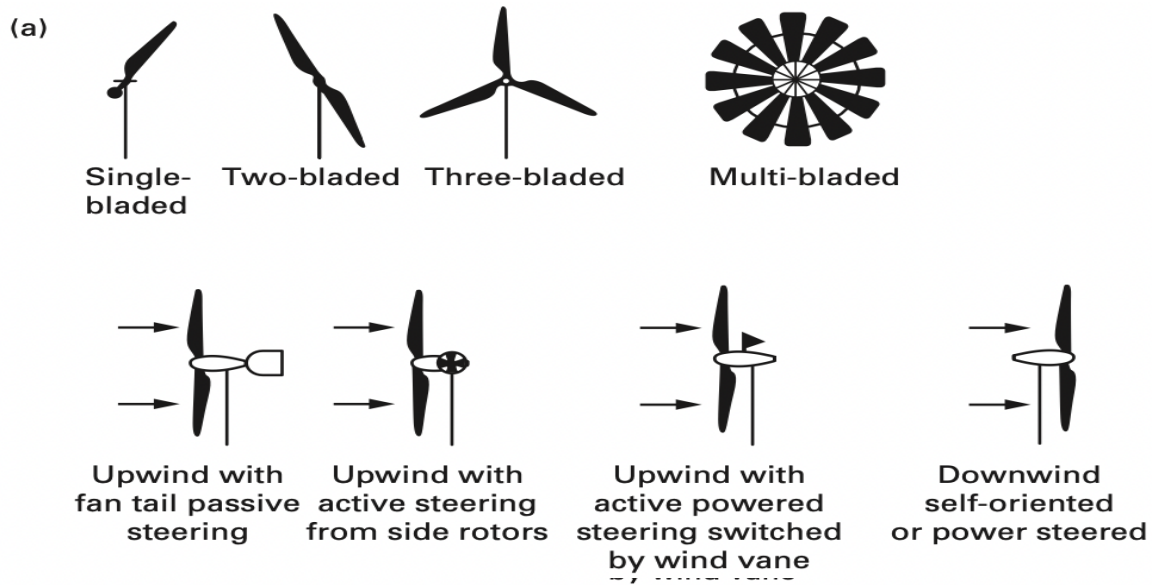

Figure 4 Classification of wind machines and devices: (a) horizontal axis; (b) vertical axis; (c) concentrators.(4)

### **3.1.1 Parts:**

- **Guide wire**

Guide wire is typically used in vertical axis wind turbines to hold the rotor shaft in place and to minimize mechanical vibration. (8)

- **Hub**

The hub is the rotor's centre, to which the rotor blades are joined. The most common materials are cast iron and cast steel. (8)

- **Rotor**

The rotor is the heart of a wind turbine, and it is made up of numerous rotor blades connected by a hub. It is the turbine component that oversees receiving wind energy and converting it into mechanical motion. The amount of energy that the rotor can extract from the wind grows as the overall diameter of the rotor design increases. (8) As a result, turbines are frequently designed around a specific rotor diameter and the expected energy that can be extracted from the wind.

- **Blades**

Rotor blades are vital to wind turbines. Aluminium, fiber glass, and carbon fiber are used because of their excellent strength-to-weight ratio. The rotor's design is affected by blade designs. Rotor blades "grab" wind and transform it into hub rotation. Two blades are used by VAWT. Blades of drag (Savonius wind turbine). (8)

Types of lift force blades (Darrieus and Giromill wind turbine) axis wind turbines (HAWT)

- **Shaft**

The shaft is the portion that the turbine blades turn. It is then linked to the generator within the main housing. (8)

- **Brake**

Dumping generator energy into a resistor bank converts turbine spinning kinetic energy into heat, slowing a small wind turbine. If the generator's kinetic load suddenly drops or is too small to keep the turbine speed within limits, this technique works.

Cyclic braking slows blades, increasing stalling and decreasing efficiency. In stronger gusts, the turbine's rotation can be maintained at a safe speed while keeping (nominal) power output. Large grid-connected wind turbines rarely use this technology.

Some turbines have a mechanical brake on the low-speed shaft between the turbine and the gearbox, while others have it on the high-speed shaft between the gearbox and the generator.

(8)

In strong gusts or overspeed, a mechanical drum or disk brake stops the turbine. As a backup to the rotor lock, this brake stops the turbine for maintenance. Blade furling and electromagnetic braking reduce turbine speed by 1 or 2 rotor RPM before using such brakes. Because mechanical brakes can cause nacelle fires. At rated RPM, the brake increases turbine load. The main control box powers these hydraulic mechanical brakes

- **Gear**

The gear box's main role is to take a low rotational speed from the shaft and raise it to increase the rotational speed of the generator. Planetary, helical, parallel shaft, spur, and worm gear stages are examples of gear stages. In several phases, two or more gear kinds can be mixed. They are constructed from aluminium alloys, stainless steel, and cast iron. (8)

- **Generator**

Generators generate electricity from rotational mechanical energy. Wind energy systems have used many generators. Commercial-sized horizontal-axis wind turbines' generators are in nacelles on towers behind the rotor hub. Wind turbines create electricity using asynchronous machinery directly connected to the grid. Wind generators revolve between 5 and 20 rotations per minute, while directly coupled devices rotate between 750 and 3600. Thus, a gearbox connects the generator and rotor hub. This decreases generator weight and cost. (8)

- **Base**

### **3.2. Horizontal axis wind turbines (HAWTs)**

The hub and blades of two- or three-bladed HAWTs are the most common energy generators. Three-bladed rotors are smoother and quieter than two-blades. Two-bladed turbines "wobble" while three-bladed ones spin smoothly. Full-scale field tests of asymmetric single-bladed rotors with counterbalances revealed too many issues for commercial use. Gearing and generators are in a tower nacelle. Water pumping and other low-frequency mechanical power uses multi-blade rotors with strong starting torque in light winds.

All wind turbines have wings-like blades (and, but less so, to airplane propellers). (4, 5)

Fig.4 shows lift as the main driving force. (c). Rotor blades can face the tower upwind or downwind. To follow the wind without oscillation, the rotor must yaw. Upwind turbines need tails or electric motor drives to keep their course. Downwind turbines are supposed to self-orient, but the tower causes wind shadow and blade path turbulence. This perturbation generates structure cyclic stresses, noise, and output fluctuations. Upwind and downwind machines with rotor diameters over 10 m control yaw with electric motors (4, 5).

### 3.2.1. Wind turbine configuration

Three-bladed horizontal-axis turbines dominate modern large wind turbines. The nacelle on top of a wind tower stores most of a wind turbine's components. The primary shaft connects the gearbox to the rotor hub.

Gearbox output shaft connects the electricity generator rotor. Thus, the rotor hub's moderate speed is increased to the generator rotor's high speed.

The pitch control system pitches each blade separately to maximize its angle of attack in normal operation and safeguard turbine components (blade, tower, etc.) in emergencies. The yaw control system uses wind blade input to keep the turbine facing the wind. (4, 5)

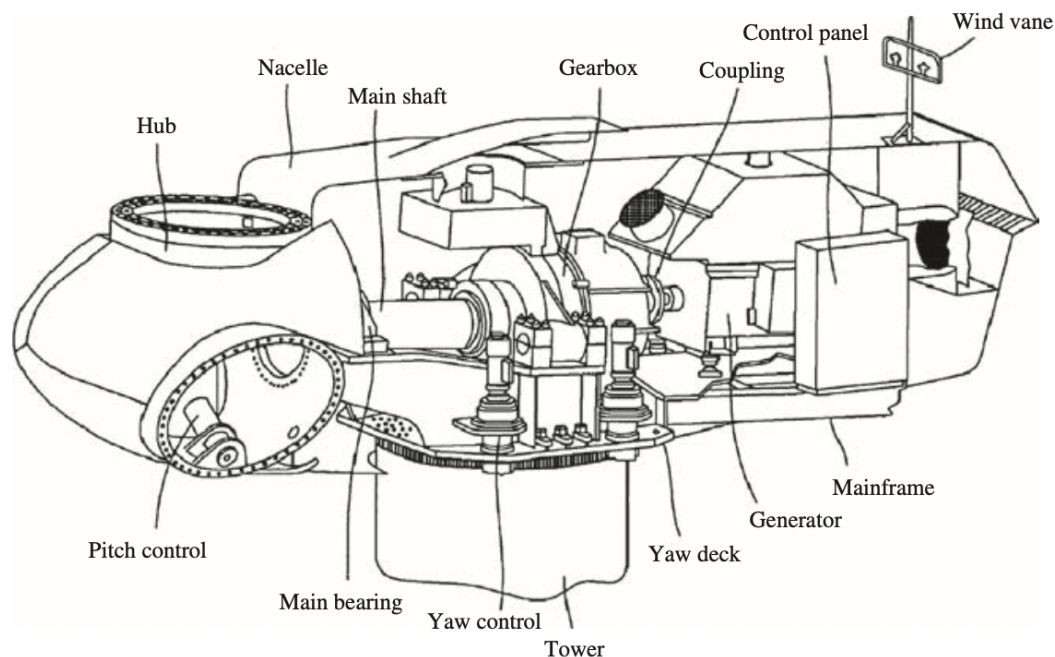

Figure 5 A horizontal-axis wind turbine configuration. (5)

### 3.3 Vertical-axis wind turbines (VAWTs) (4, 5)

A machine receive wind from any direction by turning about a vertical axis, whereas a horizontal axis machine must spin (i.e., turn in the horizontal plane to face the wind). Vertical axis wind turbine generators are expected to have gearboxes and generators at ground level.

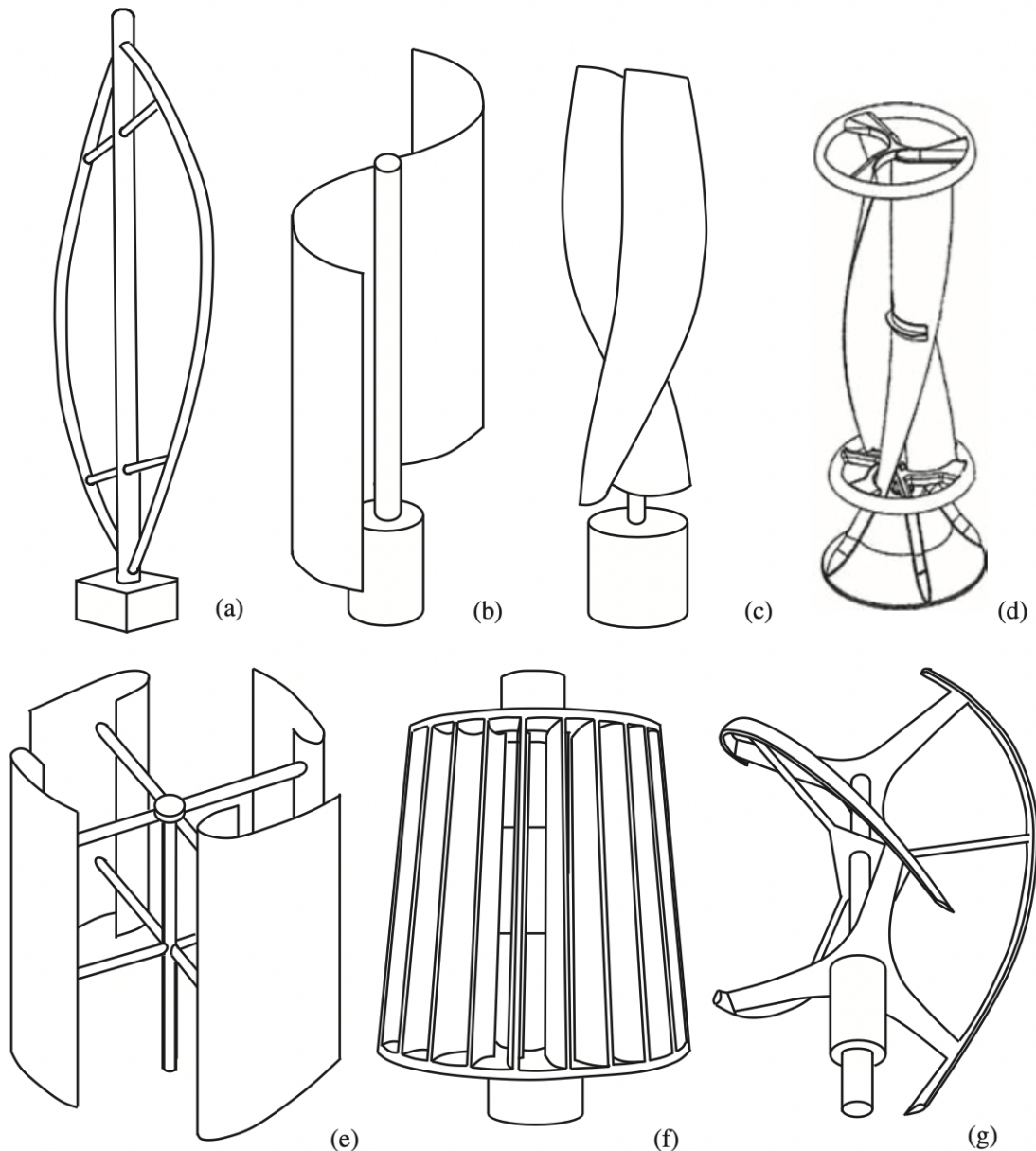

Figure 6 Several typical types of vertical-axis wind turbines: (a) Darrius; (b) Savonius; (c) Solarwind TM; (d) Helical; (e) Noguchi ; (f) Maglev ; (g) Cochrane (5)

#### Types of VAWTs:

1. Cup anemometer: This device operates based on drag force. Because of the cups' shape, there is a nearly linear relationship between rotational frequency and wind speed, so

counting the number of rotations per period correlates to the average wind speed over that time. The instrument is a standard anemometer for collecting meteorological data. (5)

2. Savona's rotor: (turbo machine). The wind moves in a complicated pattern through and around the two curved sheet air foils. Drag is the primary driving force. Like all drag machines, it has a low operating tip speed ratio. This makes it less suitable for electricity generation than devices with higher tip speeds since a high shaft speed is generally preferred to minimize the gearbox's step-up ratio requirement of a rotor coupling to a conventional electrical generator. The building is simple and inexpensive. Because of the high starting torque produced by the high solidity, Savonis rotors can be used for water pumping. (5)

3. Darrieus rotor: Darrieus' breakthrough was to dramatically increase the VAWT blades' velocity above the freestream wind velocity, allowing lift forces to be exploited to improve VAWT performance above drag-only versions.

The "eggbeater" geometry of the Darrieus turbine, seen in Fig. 7a, minimizes blade bending moments induced by centrifugal forces. The Troposkein's curving blade resembles a skipping rope without gravity, hence its name.

Due to inadequate torque to overcome friction at start-up, the Darrieus family can't self-start. At low rotational speeds, lift forces on the blades are modest, and for two-bladed machines, the torque generated at start-up is almost same for each stationary blade, regardless of the rotor azimuth angle relative to the incoming wind direction. Darrieus rotor blades are stuck at most azimuth angles at low tip speed ratios. Thus, large commercial machines must be driven at a high tip speed to accelerate the rotor in each wind velocity.

Two-bladed Darrieus machines can self-start unexpectedly, which is beneficial but can cause problems. (5)

4. Musgrove rotor: Its blades are vertical for power generation but tip or turn about a horizontal point for control or shutdown. All models are designed for high-wind shutdown. (5)

The Darrieus and Musgrove rotors' lift forces produce optimum turbine torque when a blade moves twice per rotation across the wind, pulsing the rotation. One application generates electricity. The generator can start the rotor, which isn't self-starting.

Vertical axis machines eliminate gravity-induced stress/strain cycles on blades, allowing them to be much larger. The vertical main shaft at ground level can connect small machine gearing and generators. However, huge machinery requires a long main shaft with significant torque. The generator should be raised to the center of rotation, like a horizontal axis machine. VAWTs have three main drawbacks: (1) many vertical axis machines have fatigue failures due to the various natural resonances in the structure; (2) wind rotational torque fluctuates periodically throughout each cycle, causing undesirable power periodicities at the output; and (3) guyed tower support is difficult. Thus, most operational machines have horizontal rather than vertical axes. (4, 5)

## **4. Linear momentum theory**

In this subsection, we determine the fundamental relationships between power, thrust, and torque for working wind turbines. Wind turbines are installed in open areas where strong winds blow over long periods of time. A wind turbine's output is limited because the air that flows through it cannot be directed to a location where none exists. The air must have enough momentum to continue moving downwind of the turbine. (4)

## 4.1. Energy extraction; Lanchester-Betz-Zhukowsky theory

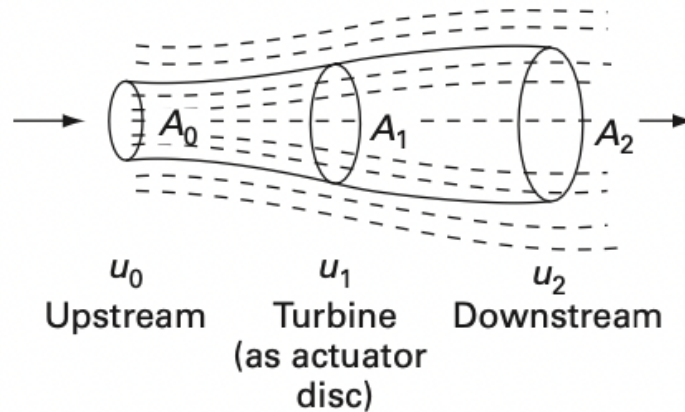

Figure 7 Lanchester-Betz-Zhukowsky model of the expanding airstream through the turbine rotor, modelled as an actuator disc. (4)

In Fig. 7, an upstream wind column with cross-sectional area  $A_1$  of the turbine disk has kinetic energy passing per unit time of:

$$P_0 = 1/2\rho A_1 u_0^3 \quad (4)$$

Here,  $\rho$  denotes the air density and  $u_0$  the unaffected wind speed. This is the wind's power at speed  $u_0$ . The air density  $\rho$  is only weakly affected by height and weather conditions. Wind speed increases with height, is influenced by local topography, and varies dramatically over time.

No turbine can catch more than  $16/27$  (59.3%) of the kinetic energy in wind, according to Betz's law. Practical utility-scale wind turbines reach a maximum efficiency of 75-80% of the Betz limit. [9]

$$P = 0,5C_p\rho\pi R^2 v^3$$

Where:

$C_p$  is the coefficient of performance [%]

$\rho$  is air density [Kg/m<sup>3</sup>]

R is the blade length [m]



$V$  is the wind speed [m/s]

The rotor is modelled as an 'actuator disk' across which air pressure changes as energy is extracted. As a result, the wind's linear momentum and kinetic energy drop; it is this loss of linear momentum and kinetic energy that is now being investigated. Angular momentum is not considered, despite the turbine turning and wakes and vortices occurring in the airstream. The model also assumes no frictional energy loss. Despite these simplifications, the model is quite useful.

## 4.2. Thrust (axial force) on wind turbines.

Strong winds must not knock a wind turbine over. The thrust on a horizontal axis machine is focused on the turbine axis and is referred to as the axial thrust  $F_A$  (see Fig. 8 (a)). This thrust generates an overturning torque, which is resisted by the tower foundation, which is made of a huge reinforced concrete block embedded in the earth. (4, 5)

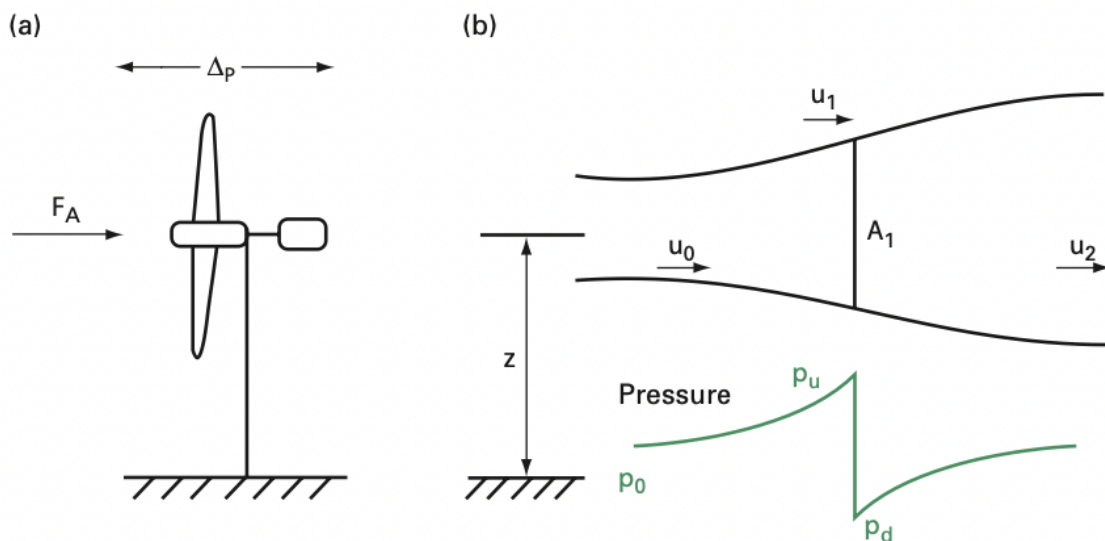

Figure 8 Thrust on wind turbines (4)

The force provided by this model for wind impacting a solid object with frontal area  $1/2 * (\rho A_1 u_0)$ . The axial force (or thrust) coefficient  $C_F$  is the fraction of this force experienced by the actual turbine, so that:

$$F_A = 1/2 * (\rho A_1 u_0^2) C_F \quad (11)$$

$$C_F = 4a(1 - a)(12)$$

where the axial induction factors  $a$  is

$$a = (u_0 - u_1)/u_0 = (u_0 - u_2)/2u_0 \quad (13)$$

Due to edge effects, the maximum value of  $C_F$  on a solid disk is around 1.2 rather than 1.0. Nonetheless, linear momentum theory indicates that when extracting power, the turbine appears to the wind as a near-solid disk. It is highly incorrect to estimate the forces on a rotating wind turbine by imagining the wind passing unaffected through the spaces between the blades. When the turbine extracts power efficiently, these gaps are not visible to the wind, and extraordinarily huge thrust forces occur. (4)

Because wind turbine thrust forces increase as  $(A_1 u_0)$ ., control strategies are used to protect the machines at wind speeds greater than about *15 to 20 m/s*, such as:

1. turning (yawing) the rotor out of the wind.
2. lessening power extraction and thus thrust by pitching the blades or extending spoil flaps.
3. if blade pitch is fixed, the blades are designed to become inefficient and self-stalling in high wind speeds.
4. to stop the rotation by blade pitching and/or braking.

Method (3) is possibly the safest and least expensive; nevertheless, self-stalling blades have a lower power coefficient and do not provide optimal power extraction or smooth power regulation.

Method (2) is favoured for big commercial machines using blade pitching (rather than spoil flaps), because power performance can be optimized and regulated in severe winds, and the rotation can be stopped if necessary. (4)

## 5. Storage technologies

Because it is a highly ordered form of energy that can be efficiently transformed into other forms, electricity has a wider range of applications than other forms of power. It can, for instance, be turned into heat or mechanical form with an efficiency of nearly 100%. Since heat energy is a disrupted kind of energy in particles, it can't be changed into power with such extraordinary effectiveness. As a result, a typical fossil thermal power plant's overall thermal-to-electrical conversion efficiency is less than 50%. Large-scale electricity storage is difficult, which is a problem. Today, almost all electric energy is used as it is created. This is not a problem in traditional power plants, because fuel consumption is continually changed in response to load requirements. Wind and photovoltaics (PVs), both intermittent power sources, cannot supply load demand at all times, 24 hours a day, 365 days a year. As a result, energy storage is a desirable element to include in such power systems. It has the potential to dramatically enhance load availability, which is a critical need for any power system.(9)



*Figure 9 Energy storage technologies. (9)*

### 5.1 Pumped-hydroelectric energy storage (PHES)

Pumped hydro is the oldest and largest commercially viable energy storage technology, with existing plants ranging in size from 100 to 1000 MW. Traditional pumped hydro employs two vertically divided reservoirs of water. Energy is stored by transporting water from the lower reservoir to the higher reservoir and extracted by letting the water return to the lower

reservoir (see Fig. 10). The fundamental physics principle of potential energy governs how energy is stored.

Although pumped hydro is largely used to shape electric utilities, it is fundamentally a mechanical energy storage method. Electric pumps move water from the lower reservoir to the upper reservoir during off-peak hours. The flow of water is reversed to create energy as needed. Some high-dam hydropower facilities can store water as pumped hydro storage. Although theoretically feasible, the expense of employing flooded mine shafts or other cavities for underground pumped storage is likely to be prohibitively expensive. If a sufficient higher reservoir can be built nearby, the open sea can likewise serve as the lower reservoir. (5, 10)

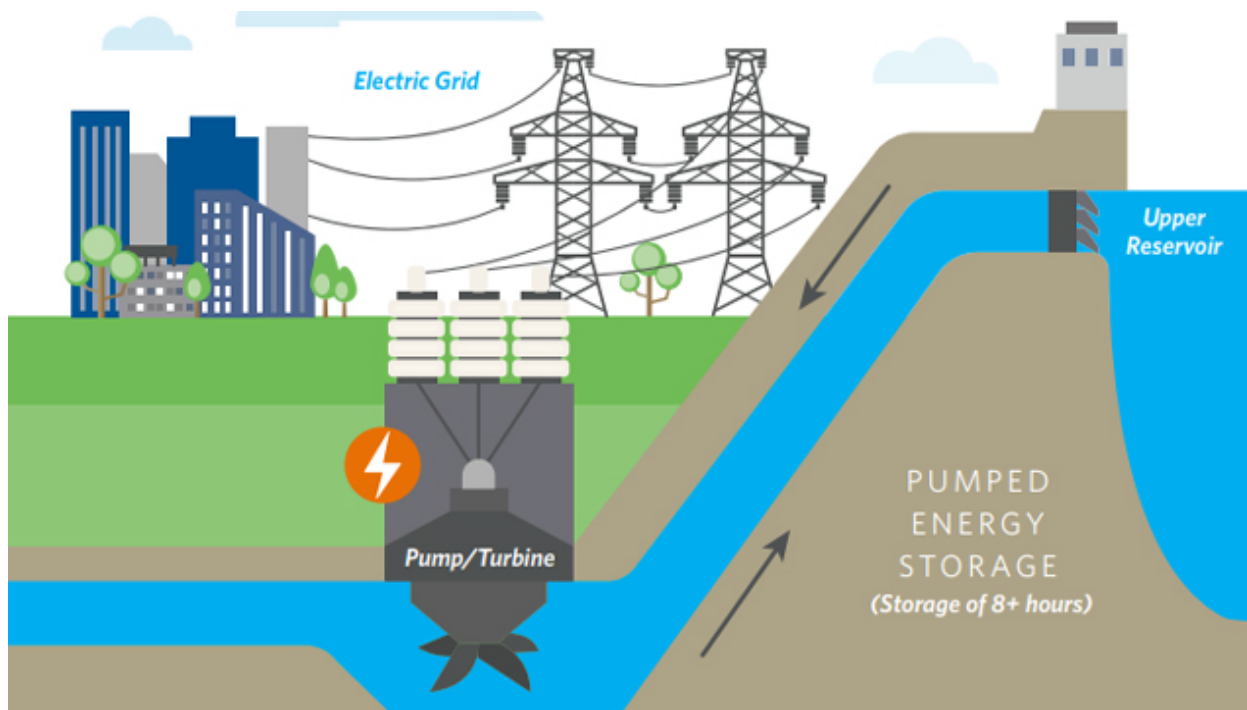

*Figure 10 Pumped-hydroelectric energy storage (11)*

Operating pumped storage facilities have an efficiency range of 50-85%, with more contemporary systems at the higher end. However, this is now being improved with the introduction of variable speed machines. The effectiveness of the pump/turbine unit utilized in the facilities is what limits it. The storage substance for PHES units has always been fresh water. (See Fig. 11).



*Figure 11 Wendefurth Pumped-storage Power Plant (12)*

The hydraulic head—the vertical distance that separates the upper and lower reels—of a typical PHES facility is 300 meters. The energy stored (kWh) is a function of the reservoir volume and hydraulic head, while the power capacity (kW) is a function of the flow rate. The following relationship can be used to determine a PHES facility's mass power output:

$$P_C = \rho g Q H n$$

where  $P_C$  is the power output in  $W$ ,  $\rho$  is the water's mass density in kilograms per cubic meter,  $g$  is the acceleration caused by gravity in meters per second,  $Q$  is the flow rate through the turbines in meters per second,  $H$  is the effective head in meters, and  $n$  is the efficiency.

[5][9]

Additionally, the following equation can be used to determine the storage capacity of the PHES:

$$E_s = V d g h$$

$V$  is the volume of water raised (in cubic meters)

$d$  is the density of water (1000 kg/m<sup>3</sup>)

$g$  is the acceleration due to gravity (9.8 m/s<sup>2</sup>)

$h$  is the elevation difference between the reservoirs (in meters), also known as the head.

It is obvious that the head and volume of the reservoirs affect both the power and storage capacity. The largest hydraulic head rather than the largest upper reservoir should be considered while designing facilities. [9] Because less material needs to be removed to create the necessary reservoirs, smaller piping is required, resulting in smaller boreholes during drilling, and the pump turbine is physically smaller, it is much less expensive to build a facility with a large hydraulic head and small reservoirs than one of the same capacities. Currently, approximately 90 GW, or around 3% of the world's total generating capacity, are housed in more than 240 PHES facilities worldwide. Electrical energy from individual facilities' power plants with ratings between 30 and 4000 MW can be stored for up to 15 GWh. (5, 10)

## **Applications of PHES**

PHES has a fast reaction time and a large storage capacity, making it excellent for load levelling applications where the plant can adjust its effective load on the system from the full name plate rating in the positive direction (pumping) to the negative direction (producing). Facilities can react in 10 minutes or less from full shutdown to full power. On standby, full power can be reached in 10–30 s. (5)

Since variable speed machines were introduced, PHES systems may now regulate frequency in pumping and generation modes (this has always been available in generating mode). This permits PHES units to absorb power more cost-effectively, making the facility more useful, increasing efficiency by 3% [3], and extending its life. Due to its enormous power capacity and discharge time, PHES can be employed for peak generation and black starts. (5)

## 5.2. Compressed air energy storage (CAES)

A CAES facility has a power train motor that drives a high-pressure turbine (HPT), a low pressure turbine (LPT), and a generator (see Fig. 12).

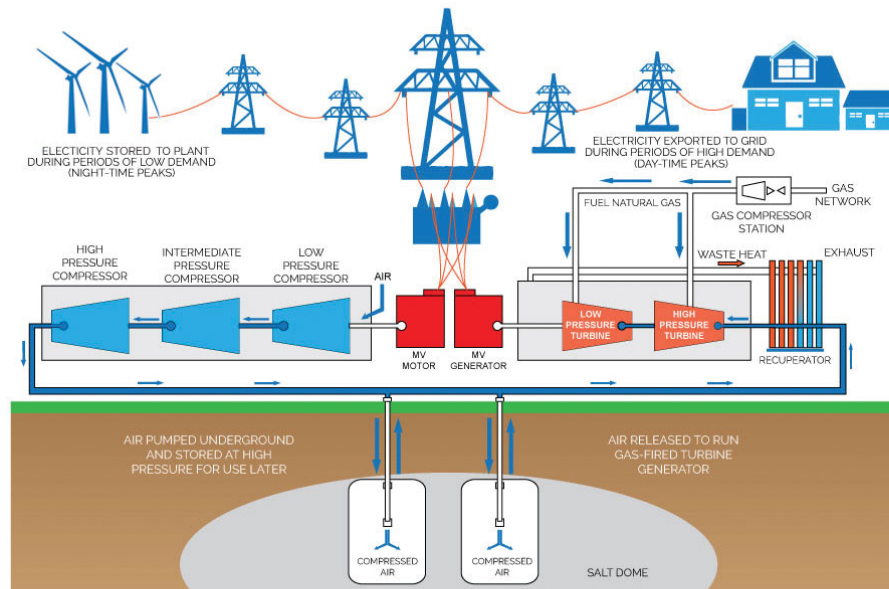

Compressed Air Energy Storage (CAES)

Figure 12 Compressed Air Energy Storage (CAES) (13)

Compressed air and fuel burned in the combustion chamber drive the turbine blades in the expander, which generates power. A compressor integrated on the same shaft as the turbine is used in conventional gas turbines. The compressor that delivers air to the combustion chamber uses about 60% of the mechanical power that the expander generates.

A CAES facility separates the compressor's work, stores the compressed air, and then injects it into a simplified combustion turbine at a later time. The expansion turbine and the combustion chamber are the only components of the simplified turbine. Because compressed air contains potential energy, this simplified turbine generates significantly more energy from the same fuel than a conventional turbine. The energy that is stored in compression is responsible for the portion of the output energy that is greater than what would have been produced by a conventional turbine. (14)

The heat energy lost during compression limits the storage's net efficiency for a CAES plant. Energy storage has an overall efficiency of about 64% to 75%.

CAES blowers work on framework power during off-peak times and utilize the development turbine to supply top power when required. Because the exhaust air would exit at extremely low temperatures, causing issues with brittle materials and icing, CAES facilities cannot operate without combustion. (See Fig. 13) Biofuel could be used to power the gas turbines if the goal is to generate 100% renewable energy. Even if the system is carbon-neutral, there may still be issues with emissions.(5, 13)



*Figure 13 Working Compressed Air Energy Storage (CAES)(13)*

## **Applications of CAES**

CAES is the only large-scale storage method except PHES. CAES plants can reach 100% in less than 10 min, 10 to 100% in 4 min, and 50 to 100% in 15 s. Thus, it can frequently start and stop and operate as a huge sink for bulk energy supply and demand. A 5°C ambient temperature increase reduces air density, reducing typical gas turbine (GT) efficiency by 10%. Compressed air prevents this effect in CAES. CAES facilities do not overheat like typical GTs when operating at partial load. Due to its adaptability, CAES can control voltage,



load following, and frequency. CAES is now a major wind power energy storage player. Some of the examples are the facility ‘The Hybrid Renewable Energy System project in South Australia and The Yangjiang Nanpeng Island CAES project in China’. Integrating a CAES facility with local wind farms is one option. A CAES facility might compress air using off-peak wind farm power. (5)

## **5.3 Battery energy storage (BES)**

There are three kinds of large-scale BES. These are lead-acid (LA), nickel-cadmium (NiCd), and sodium-sulfur (NaS). These work in the same way as traditional batteries, but on a larger scale: two electrodes are immersed in an electrolyte, allowing a chemical reaction to take place and produce electricity when needed. (5)

### **1. LA battery**

This is the most well-known sort of battery-powered battery utilized today in light of its development and superior execution over-cost proportion, despite the fact that it has the least energy thickness by weight and volume. When a Pb-acid battery is discharged, water and lead sulfate are created, the sulfuric acid electrolyte is diluted by the water, and the electrolyte's specific gravity decreases as the state of charge (SOC) decreases. The reaction that results in the formation of lead and lead dioxide at the negative and positive plates, respectively, is reversed when the battery is recharged, bringing it back to its initial charged state. These advantages come with greater starting costs and shorter lifetimes. (10)

The electrode size and geometry determine LA battery power and energy. LA batteries reach full power in milliseconds. LA batteries have a lifespan of 5 years or 250–1000 charge/discharge cycles, depending on discharge depth, with a DC–DC efficiency of 75–85% (5, 15).

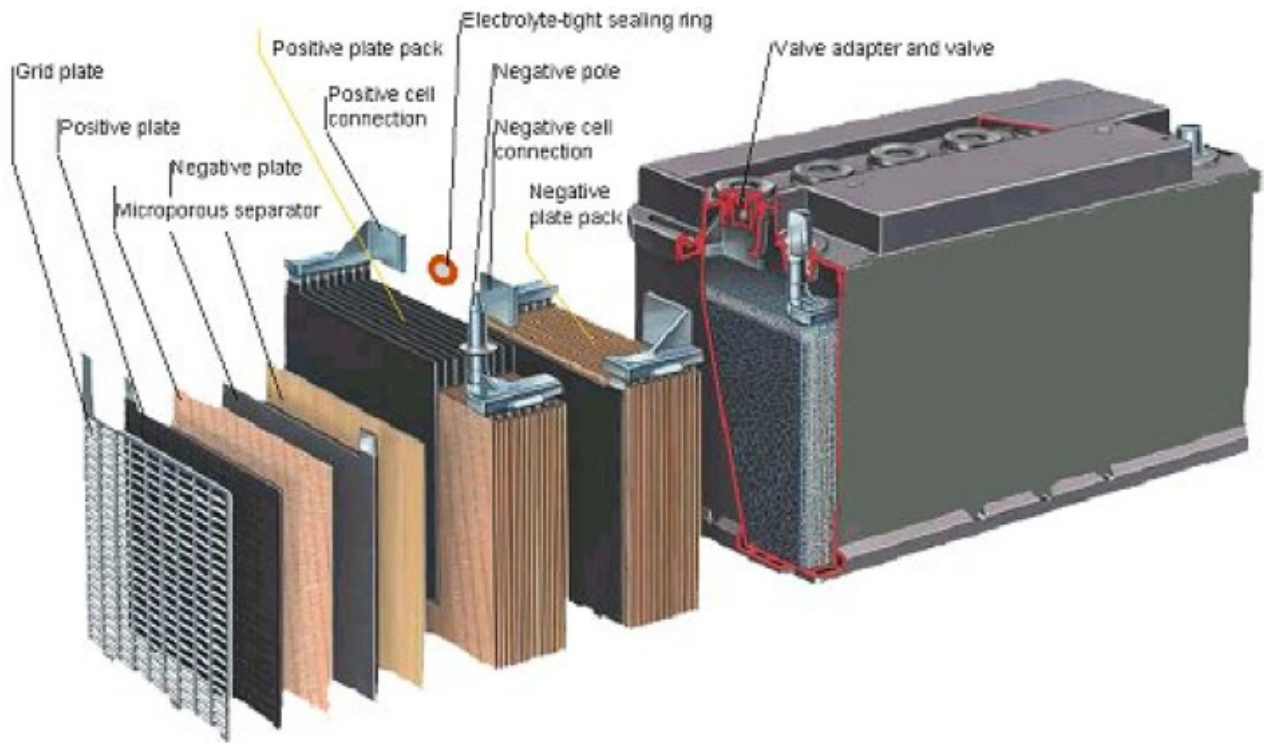

*Figure 14 LA battery(15)*

## **2. NiCd battery**

A NiCd battery has a metallic cadmium negative electrode and a nickel oxyhydroxide positive electrode (see Fig. 15). NiCd battery structure is assembled from the electrode plates with Nylon dividers separators between them. Two different types of NiCd batteries are produced. The first shape consists of sealed batteries and submerged electrodes with liquid electrolytes. NiMH batteries and NiCd batteries are very identical. (10, 16)

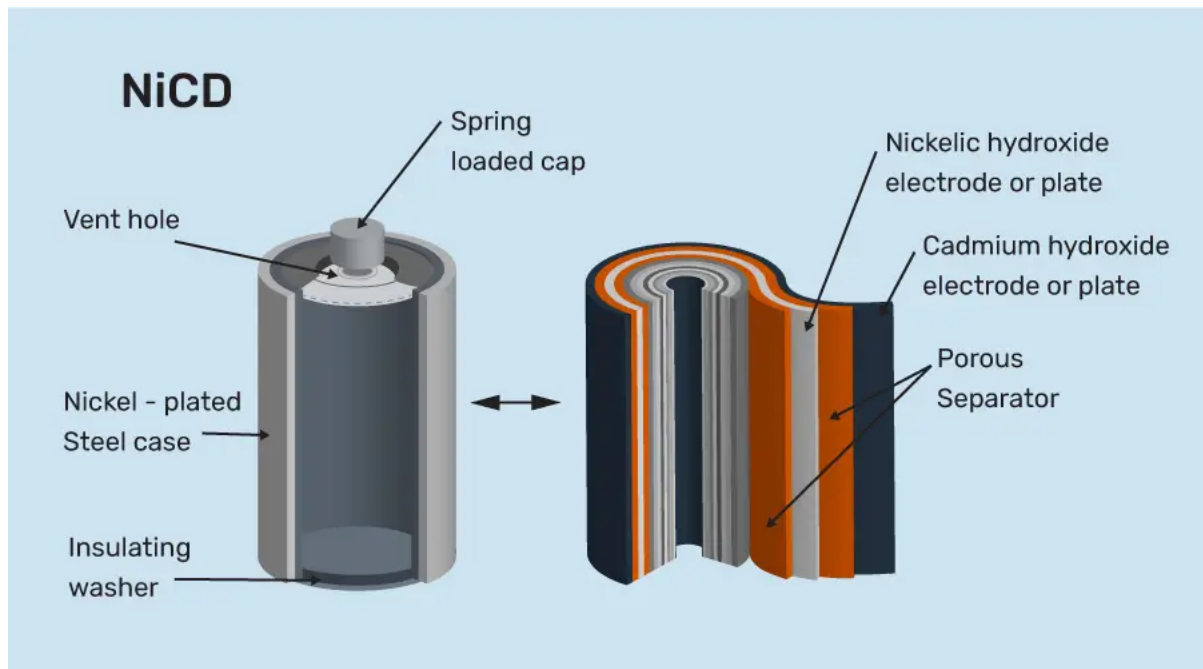

Figure 15 NiCd battery (16)

### Applications of NiCd battery:

Lightweight, portable, and rechargeable sealed NiCd batteries are utilized in commercial electronics like remote controls. Aircraft and diesel engine starters employ vented NiCd batteries for high energy density. NiCd batteries are excellent for providing standby power in challenging circumstances and protecting power quality against voltage drops. Because they can resist high temperatures, NiCd batteries have become popular solar storage. They are typically avoided for energy management systems because they don't work well in reducing peak hours applications. (10)

### 3. NaS battery

A sodium-sulfur (NaS) batteries offer threefold the energy density compared to LA batteries, a longer life cycle, and require fewer services. NaS battery is made up of a solid beta-alumina ceramic electrolyte separated by a liquid (molten) sulfur positive electrode and a liquid (molten) sodium negative electrode. Positive sodium ions flow through the electrolyte and mix with sulfur to generate sodium polysulfides when discharged (see Fig. 16). Initially, "x" in the formula is 5, but once free sulfur is consumed, a more sodium-rich combination of polysulfides that have lower average values of x forms. (10)

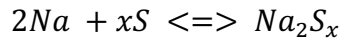

As a result of charging, sodium polysulfides in the positive electrode release sodium ions that return through the electrolyte and recombine as elemental sodium. This process can be reversed. The battery operates at approximately 300°C. At 360 kWh or 430 kWh, a typical NaS unit can produce 50 kW. A NaS battery's typical efficiency of energy ranges from 86% to 89%. The cycle life is fundamentally longer than that of LA or NiCd batteries. The NaS batteries have a 2500-cycle life at 100% Depth of discharge (DoD). As with other batteries, this rises when the DoD is lower; The unit can cycle 4500 times at 90% DoD and 40,000 times at 20% DoD. (17)

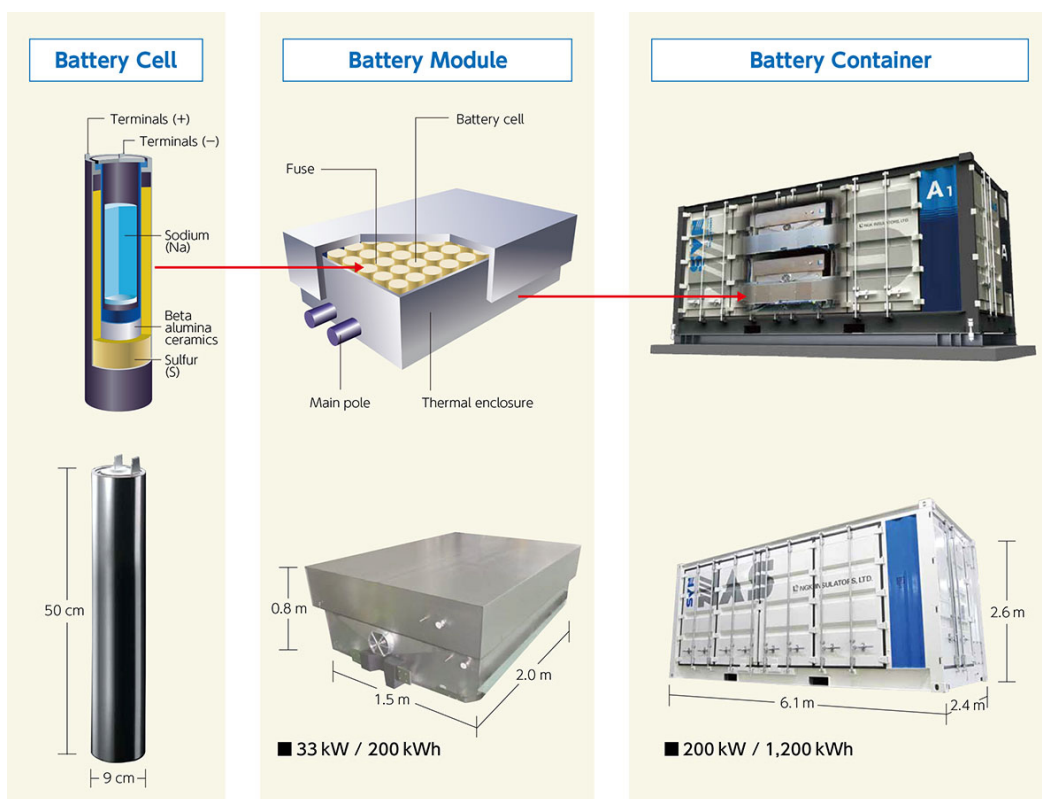

Figure 16 Structure of NAS Energy Storage System(17)

## 5.4 Flow battery energy storage (FBES)

There are three main forms of FBES: zinc-bromine (ZnBr), polysulfide bromide (PSB), and vanadium redox (VR). All of them work in the same way: two charged electrolytes are pumped into the cell stack, where a chemical reaction takes place and produces current when it is needed. (18)

In terms of energy storage, the VR flow battery is a very adaptable technology. It may be utilized for any type of energy storage demand, including UPS, load leveling, peak shaving, communications, electric utilities, and renewable resource integration. The flow batteries' adaptability makes them incredibly helpful for a wide range of applications.



*Figure 17 Flow battery energy storage (18)*

### **Applications of VR flow battery**

In both electrolyte tanks of the VR, compounds of the element vanadium are used. The potential issue of electrolyte cross-contamination is eliminated, and recycling is made simpler, by using vanadium compounds on both sides of the ion-

exchange barrier. Despite their ability to perform for a wide range of applications, VR batteries are only considered where adaptability is critical, such as the incorporation of renewable resources. (18)

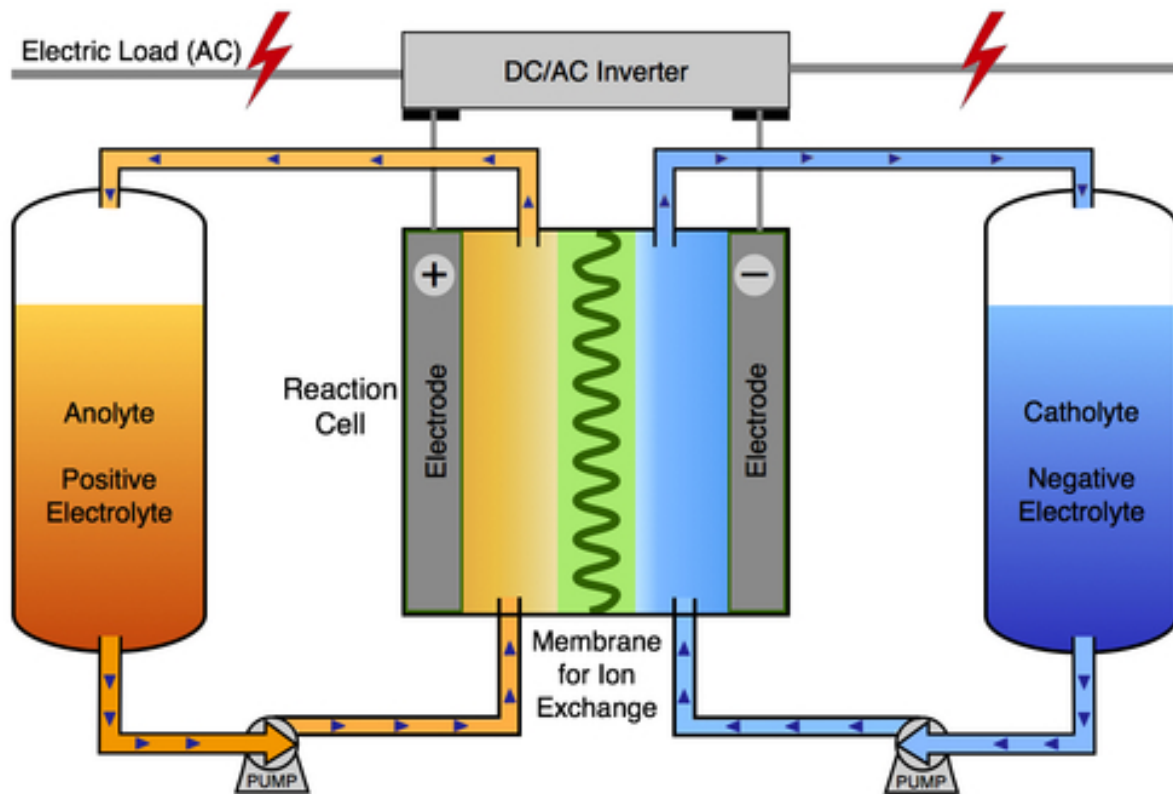

Figure 18 Inside of Flow battery energy storage (19)

### Applications of PSB flow battery

PSB batteries have a very quick reaction time; it may react within 20 ms if the electrolyte is kept charged in the stacks (of cells). PSB batteries can charge or discharge electricity in 0.1 seconds under typical conditions. PSB batteries are thus very valuable for frequency response and voltage regulation.

### Applications of ZnBr flow battery

The foundation for ZnBr flow batteries is a 25 kW, 50 kWh module made up of three 60-cell battery stacks connected in parallel, each having a 2500 cm<sup>2</sup> active cell surface. In addition, ZnBr batteries have a high energy density of 75-85 Wh/kg. As a result, ZnBr batteries are smaller and lighter than other traditional and flow batteries such as LA, VR, and PSB.

## 5.5 Flywheel energy storage (FES)

The vast majority of current flywheel energy storage systems consist of a massive rotating cylinder supported by magnetically levitated bearings on a stator. The flywheel system is operated at a low vacuum level to decrease drag and hence preserve efficiency. The flywheel is connected to a support-mounted motor, meaning it's attached to the electricity supply by electrical components. (See fig 19). (20, 21)

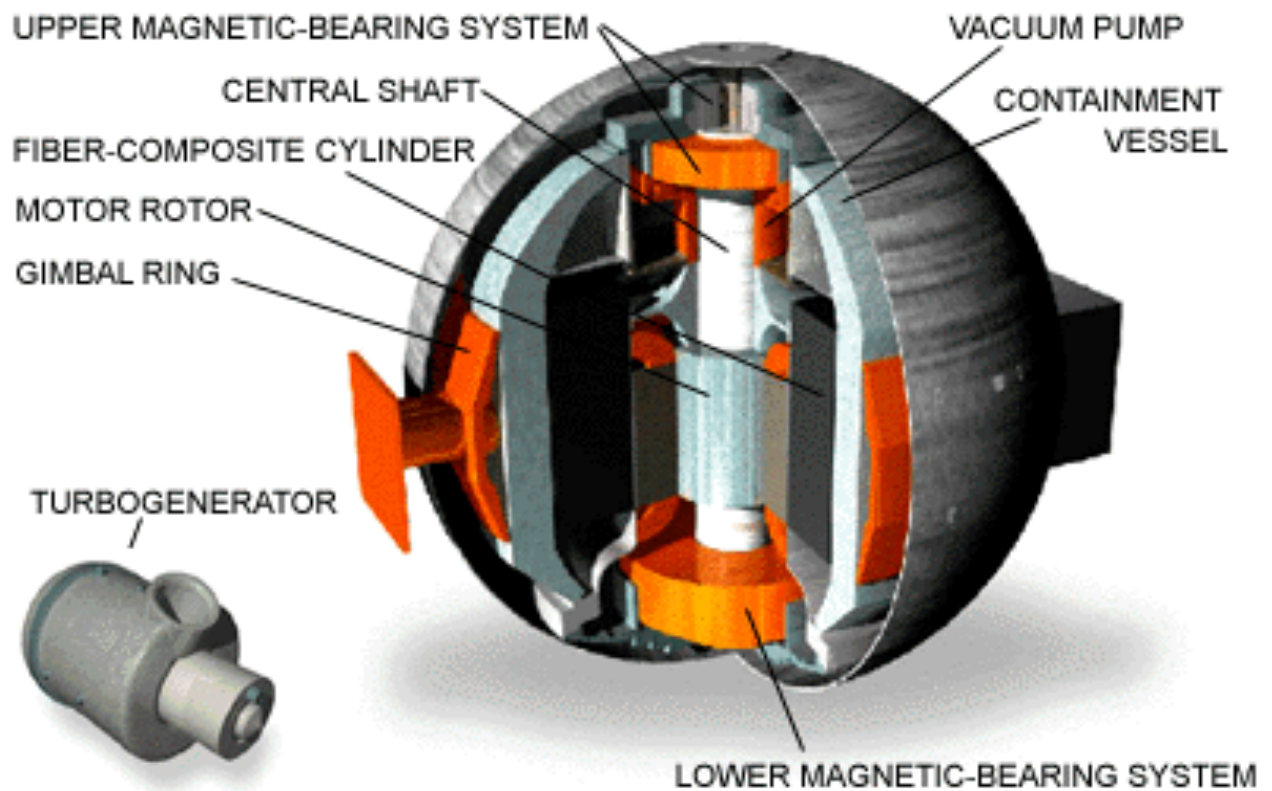

Figure 19 Flywheel energy storage(20)

Flywheel energy storage depends on the rotor. Flywheels store power in proportion to their rotor mass and surface speed squared. Thus, a flywheel stores energy most efficiently by spinning faster, not heavier. Flywheel energy density is energy per mass:

$$E_f = \frac{I \omega^2}{2} = \frac{m_f r^2 \omega^2}{2}$$

Where:

$I$  is the flywheel's moment of inertia ( $kg/m^2$ )

$\omega$  is its angular velocity ( $1/s^2$ )

Flywheels separate power and energy. Optimizing the motor/generator and power electronics yields the required power capacity. Low-speed flywheels use a steel rotor and rotate at about 10,000 rpm. They can deliver 1650 kW for 120 s. [9] High-speed flywheels spin on a lightweight rotor at faster speeds, with some prototype composite flywheels reaching 100,000 rpm. The fastest commercial flywheels spin at roughly 80,000 rpm. They can power 750 kW for an hour. Flywheel efficiency has increased to 80% or 90%. (20, 21)

### **Applications of FES**

Flywheels offer a fast dynamic reaction, a long life, minimum maintenance, and are environmentally benign. They are expected to last approximately 20 years or tens of thousands of cycles. Because the storage medium of flywheels is mechanical, the device can be discharged repeatedly and completely. As a result, flywheels are utilized for power quality enhancements such as uninterruptible power supply (UPS), absorbing waste energy that is particularly beneficial in electric vehicle (EV) applications, and dampening frequency variation, making FES very effective to smooth the uneven electrical output from wind turbines. (5, 10)

## **5.5 Hydrogen energy storage system (HESS)**

HESS, as an energy storage system, serves as a link between the three key sectors of an energy system: power, heat, and transportation. It is the only energy storage system that provides for this level of interconnection between the three sectors, making it a very appealing alternative for integrating huge amounts of intermittent wind energy. HESS has three stages: generate hydrogen, store hydrogen, and use hydrogen. (10, 14)





*Figure 20 Hydrogen storage(22)*

## **Hydrogen production**

Electrolysis can be used to produce diatomic, gaseous hydrogen ( $H_2$ ):  $O_2$  and  $H_2$  are separated from water by applying an electric current. Although oxygen has no inherent energy value, based on the development, the Higher heating value (HHV) of the following hydrogen may feature as much as ninety percent of the utilized electric energy. After that, this hydrogen can be stored and then burned to generate heat, perform work, or power a fuel cell. Low density gaseous hydrogen needs to be compressed in order to provide useful storage. Pressure to a capacity tension of 350 bar, the worth generally expected for automotives, consumes up to 30% of the hydrogen's HHV whenever performed adiabatically. In any case, the misfortune moves toward a lower cutoff of 5% as the pressure moves toward an isothermal ideal. Alternatively, using current technology, hydrogen can be kept in liquid form, which consumes around 25% of the energy and costs approximately 40% of HHV. Fluid capacity isn't feasible for auto applications since compulsory bubble off from the capacity compartment can't be securely delivered in shut spaces. An absorption process can also bond hydrogen to metal hydrides. The energy punishment of capacity might be lower for this interaction, which expects compression to just 30 bars. However, the metal hydride's density can be anywhere from 20 to 100 times that of the hydrogen it stores. Additionally, carbon

nanotubes have received attention as a potential medium for storing hydrogen. Technologies for storing hydrogen are discussed. (10, 14)

## **Storage of hydrogen**

There are several options for storing hydrogen now:

1. Hydrogen compression: Hydrogen can be compressed and stored in containers or subterranean reservoirs. The expense of putting away hydrogen in pressure vessels ranges somewhere in the range of \$11 and \$15 per kWh. However, the cost is only about \$2/kWh in the case of subsurface reservoirs. Despite its simplicity, this method has a low energy density and efficiency of 65-70%. Mechanical compression has also presented challenges. However, this is currently the most widely used method of hydrogen storage for the transportation sector, as the hydrogen is compressed to approximately 350 bars. Even though the energy required for compression is a substantial disadvantage. (5)
2. Liquefied hydrogen: By pressurizing and chilling, hydrogen can be liquefied. Despite improvements in energy density, it still costs four times as much as conventional gasoline. Furthermore, keeping the hydrogen liquid requires a significant amount of energy because it must be kept below 20.27 K. (5)
3. Hydrides of metal: Clathrate hydrate (metal hydride) and nanostructured carbons are two examples of materials that take in molecular hydrogen. Hydrogen may be easily carried and stored by absorbing it in certain materials. When needed, the hydrogen is extracted from the parent material. The energy density is comparable to that of liquid hydrogen. The additional material required to hold the hydrogen is a big issue with this technology, as it adds costs and mass. Because this is still a relatively new technology, further research could make it a viable choice, particularly if the amount of material is lowered. Higher energy densities can be achieved with carbon-based absorption. Because each storage strategy is in its early phases of development, there is no optimum approach at this time, with study being conducted in each area.

## 5.6 Other Characteristics of storages

In this section I will be speaking of different characteristics of each storage and some advantages and disadvantages.

*Table 1 Different high accumulation storages characteristics (23–27)(28)*

Type of storage	efficiency	costs per KWh	reaction time	power	Capacity
Pumped-hydroelectric	50-85%,	5-100\$	15 seconds	3GW	24GWh
Compressed air	64- 75%.	400-500\$	10 minutes	100MW	132 GWh
LA battery	75-85%	80-100\$	milliseconds	120W per cell	100-265 Wh/kg
Flow battery	70- 90%	300-700\$	110ms	100 MW	400 MWh
Flywheel	80- 90%	150-250\$	3s	100 kW to 2 mW	3-133 kWh
Hydrogen energy	65-70%	10\$	Several minutes	79MW	700 GWh

*Table 2 Advantages and disadvantages of Pumped Storage Hydropower Plants (29)*

<b>Advantages</b>	<b>Disadvantages</b>
Long service	Deep rooted arranging and development time
Low losses	Conditions specific to the upper reservoir and the lower reservoir
Relatively high efficiency	Low power and energy density
Capacity to install extremely large storage	Long time to pay off

*Table 3 Advantages and Disadvantages of CAES System (30)*

<b>Advantages</b>	<b>Disadvantages</b>
CAES systems are easily adaptable to any individual site.	The system's efficiency is relatively poor. Some demonstrations have achieved efficiencies of up to 75%, while others have achieved efficiencies as low as 40%.
They can do black starts, which means they can start up from a standstill without relying on the grid for electricity.	Require suitable geological formations..
They can store a lot of energy and produce a lot of power.	Response time is long.
They have high release term at greatest power yield	

*Table 4 Advantages and Disadvantages of Storage Batteries (30)*

<b>Advantages</b>	<b>Disadvantages</b>
They can be made in a variety of sizes and shapes to meet any requirement.	Self discharging
Low price	Temperature changes can accelerate capacity loss.
Batteries are extremely adaptable and can be placed virtually anywhere.	Impact on the environment

*Table 5 Advantages and Disadvantages of Flywheel (30)*

Advantages	Disadvantages
Environmentally friendly	Possibility of an accident at high rotation speed
Unaffected by changes in temperature.	Due to the earth's dynamic orientation, friction causes energy loss.
Long life	Moderately low release time at most extreme power level.
High energy and power densities.	

*Table 6 Advantages and Disadvantages of Hydrogen energy storage system (31)*

<b>Advantages</b>	<b>Disadvantages</b>
The Use of Hydrogen Greatly Reduces Pollution	Risks of leakage and explosions
Hydrogen can be stored for extended periods without significant degradation.	Hydrogen has a relatively low energy density it requires larger storage volumes
	Storage temperature:-253°

## 6. Electricity balance and demand

Denmark benefits from favorable wind resources, particularly in its coastal areas. The country has consistent and strong winds that are well-suited for wind power generation. This natural advantage allows for the efficient utilization of wind turbines and high electricity production potential.

Regarding the need for accumulation storage, wind energy is inherently intermittent and variable, as it depends on wind speed and availability. Accumulation storage systems, such as batteries or other storage technologies, play a crucial role in balancing the supply and demand of electricity and ensuring a stable and reliable power supply.

### 6.1. Electricity production and supply in Denmark from 2000 to 2022

Over the past decade, wind energy has experienced remarkable growth in Denmark, with its contribution to the country's electricity demand steadily increasing. Currently, wind power covers approximately 50 percent of Denmark's electricity demand, making it a significant component of the nation's energy mix. On windy days, Denmark's wind turbines can create more electricity than the country's need, resulting in surplus power.

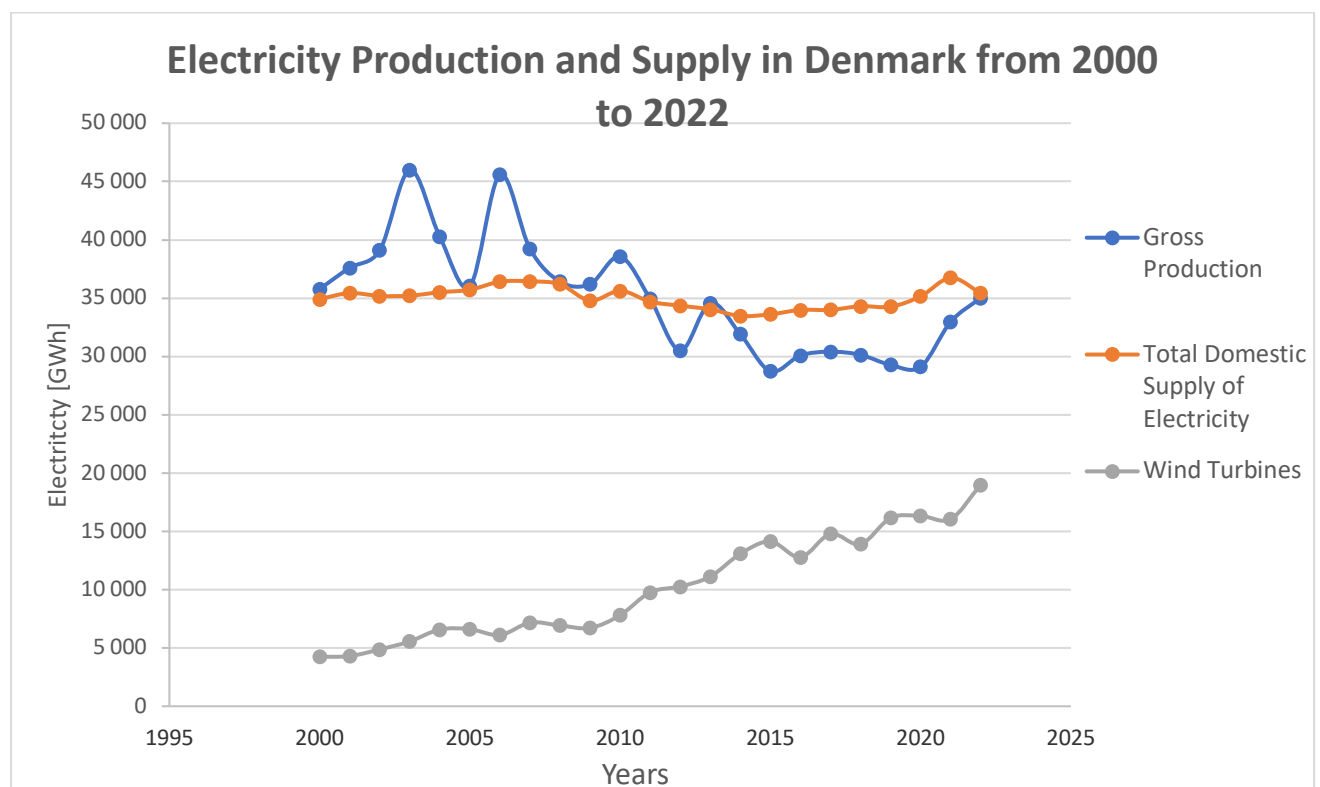

Figure 21 Electricity production and supply in Denmark from 2000 to 2022 (32)

## 6.2. Denmark electricity production in 2022 every month

Wind turbines play a pivotal role in converting wind energy into electrical energy, with their output varying depending on wind speed and availability. To address the inherent variability of wind power output, the choice of energy storage systems becomes crucial. In this context, lead-acid batteries and hydrogen storage have been selected due to their high efficiency and favorable pricing.

During periods of ample wind power generation, when the electricity produced surpasses the immediate demand, the surplus electricity is utilized to charge the lead-acid batteries or hydrogen storage. These storage systems efficiently convert the excess energy into chemical potential, allowing it to be stored for later use when wind power generation falls short of meeting electricity demand.

To ensure the harmony between the energy beneath the wind line (representing the total energy generated by wind sources) and the output of the system line (referring to the energy delivered to satisfy demand or supply requirements), energy storage technologies such as lead-acid batteries and hydrogen storage play a critical role.

By leveraging these energy storage solutions, the discrepancy between wind power generation and demand can be mitigated, leading to a more consistent and reliable supply of electricity. The excess energy captured during high wind power periods is stored in the lead-acid batteries or hydrogen storage, enabling its utilization during times when wind power generation is insufficient to meet the electricity demand.

The determination of electricity storage capacity was derived from analyzing the electricity power generation data in Denmark for the year 2022. The objective of this approach was to calculate the storage capacity required to maintain a consistent difference between the electricity supply from wind power plants and the total electricity supply. This difference would subsequently be supplemented by reliable and stable sources of electricity.

The capacity of the storage system was determined by adjusting the 'Total domestic supply' line to match the area beneath both the 'Wind energy' line and the 'Output of system storage' line. This adjustment ensures that the energy supplied by the storage system is equal to the energy generated by wind sources. As a consequence, a constant difference is observed between the 'Total domestic supply' line and the 'Output of system storage' line. The methodology employed is visually depicted in Figure 22.

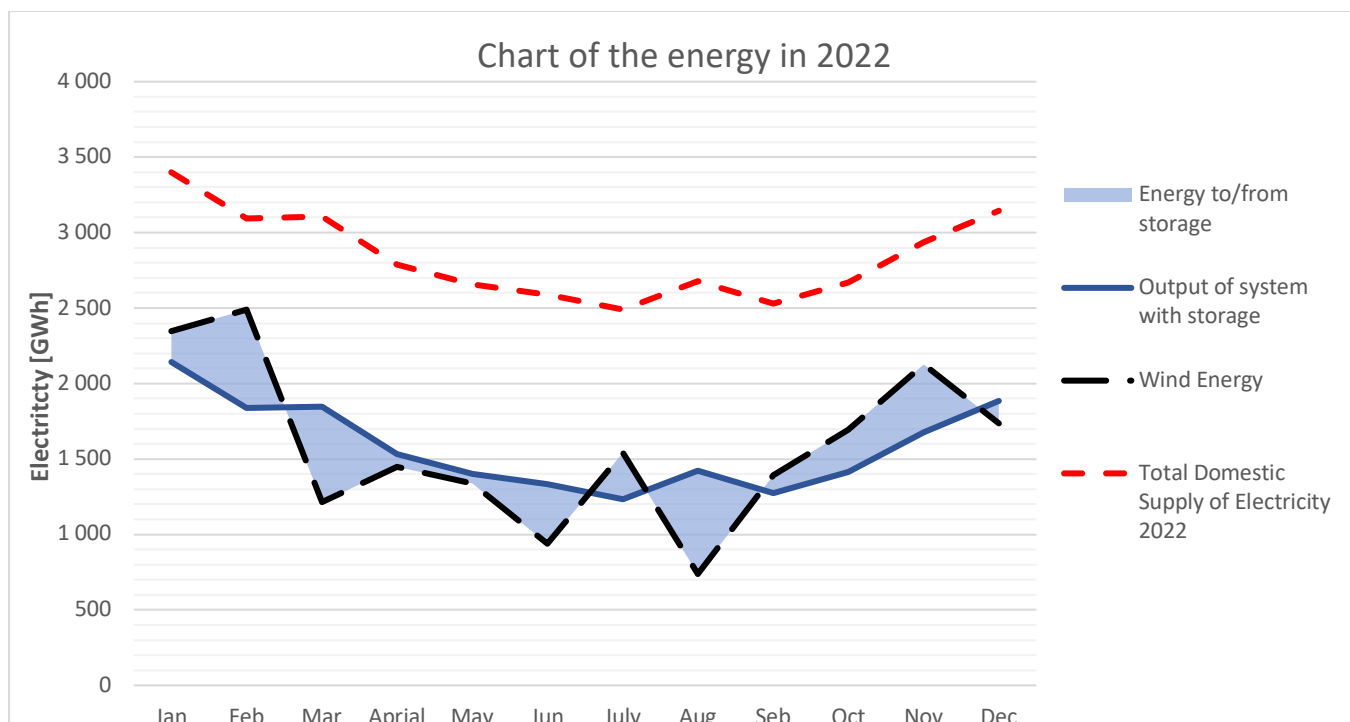

Figure 22 Denmark electricity production in 2022 every month (32)

Table 7 Data of Table 1 Data of Denmark electricity production in 2022 every month (32)

Months	Total Domestic Supply of Electricity, exc. losses [GWh]	Output of system with storage [GWh]	Wind energy [GWh]
Jan	3399.4	2015.9	2347.1
Feb	3095.2	1711.7	2489.4
Mar	3105.6	1722.1	1215.3
April	2790.2	1406.7	1446.1
May	2658.8	1275.3	1336.6
Jun	2589.3	1205.8	936.7
July	2490.2	1106.7	1542.0
Aug	2679.8	1296.3	738.1
Seb	2530.1	1146.6	1393.5
Oct	2670.1	1286.6	1692.3
Nov	2935.6	1552.1	2127.5
Dec	3399.4	1759.1	1737.4



### 6.2.1. Denmark electricity production in 2022 every month including the Lead acid battery.

Including the lead battery efficiency of 80% in the energy storage process affects the lines representing the energy generation and demand in the following ways:

During periods of excess energy generation, when the electricity production from wind power exceeds the immediate demand, the efficiency of the lead battery comes into play. With an efficiency of 80%, only 80% of the surplus energy generated can be effectively stored in the battery. As a result, the energy generation line may show a slight decrease or flattening during these periods since a portion of the generated energy is lost in the storage process. (32)

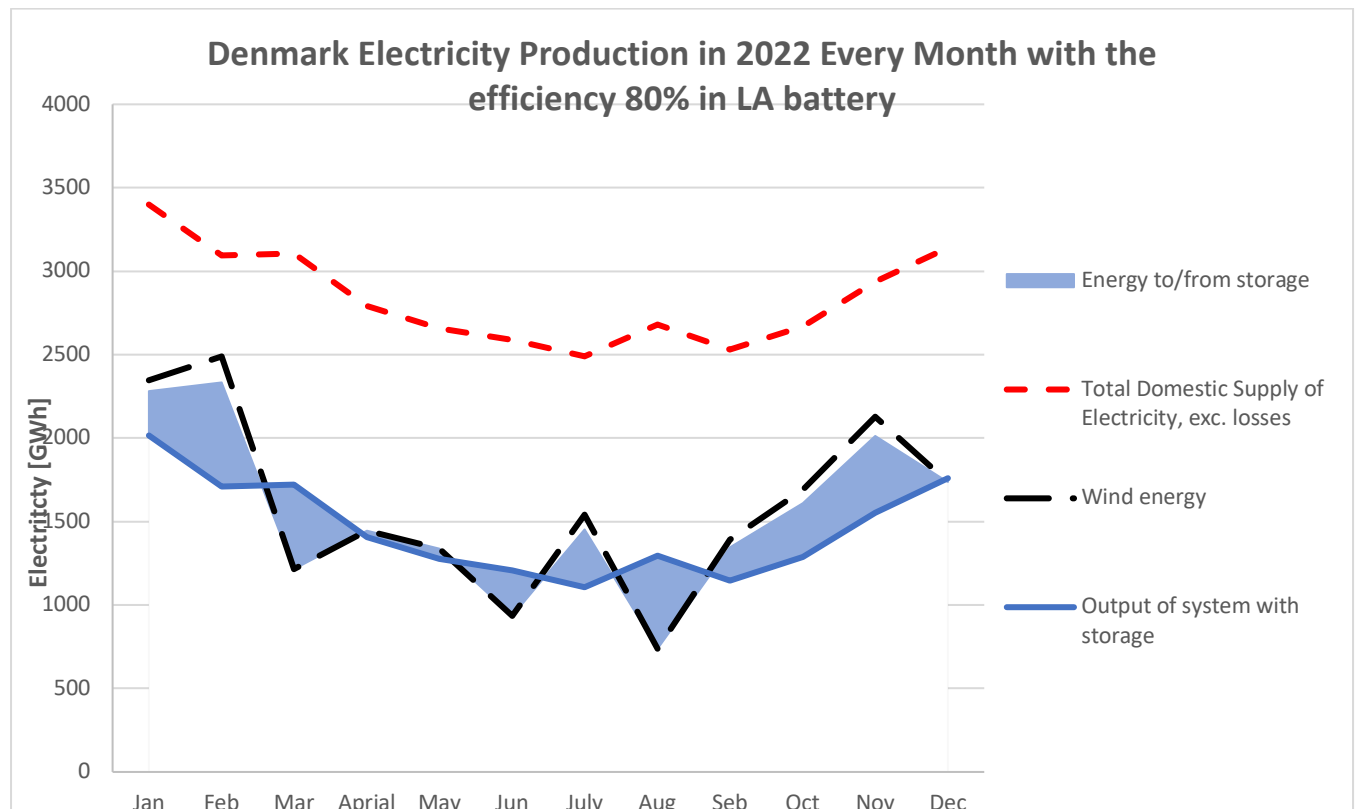

Figure 23 Denmark electricity production in 2022 every month including the Lead acid battery (32)

*Table 8 The differences between Wind production and output from the storage and the actual state of charge of the Lead acid battery storage. (32)*

Months	Energy from/to storage [GWh]	Energy to storage including its efficiency /from storage [GWh]	Energy in the storage [GWh]
Jan	331.2	265.0	265.0
Feb	777.7	622.1	887.1
Mar	-506.8	-506.8	380.3
Aprial	39.4	39.4	419.7
May	61.3	61.3	481.0
Jun	-269.1	-269.1	211.9
July	435.3	348.2	560.2
Aug	-558.2	-558.2	1.9
Seb	246.8	197.5	199.4
Oct	405.8	324.6	524.0
Nov	575.3	460.3	984.3
Dec	-21.8	-21.8	962.5

The price cost to store 1 kWh in Lead-Acid battery cost Between 80-100\$(33) in this data I choose to take 90\$ as the cost of the 1KWh Lead-Acid battery. The maximum energy added to the storage in the year 2022 was in November and can be found in the table of added accumulation storage as 984.3 GWh. The investment cost for a lead-acid battery storage of such capacity will be \$ **88 582 686 039.34**

### **6.2.2. Denmark electricity production in 2022 every month including the Hydrogen storge.**

When we include the hydrogen storage efficiency of 70% when storing the energy, it means that 70% of the energy input into the hydrogen storage system during the charging process is effectively stored, while the remaining 30% is lost as heat or other forms of energy loss.

Including the hydrogen storage efficiency of 70% in the energy storage process impacts the lines representing the energy generation and demand in the following ways:

During periods of excess energy generation, such as when wind power output exceeds the immediate demand, the efficiency of the hydrogen storage system becomes relevant. With an efficiency of 70%, only 70% of the surplus energy generated can be effectively stored in the hydrogen storage. Consequently, the energy generation line may experience a slight decrease or flattening during these periods, as a portion of the generated energy is lost during the storage process. (32)

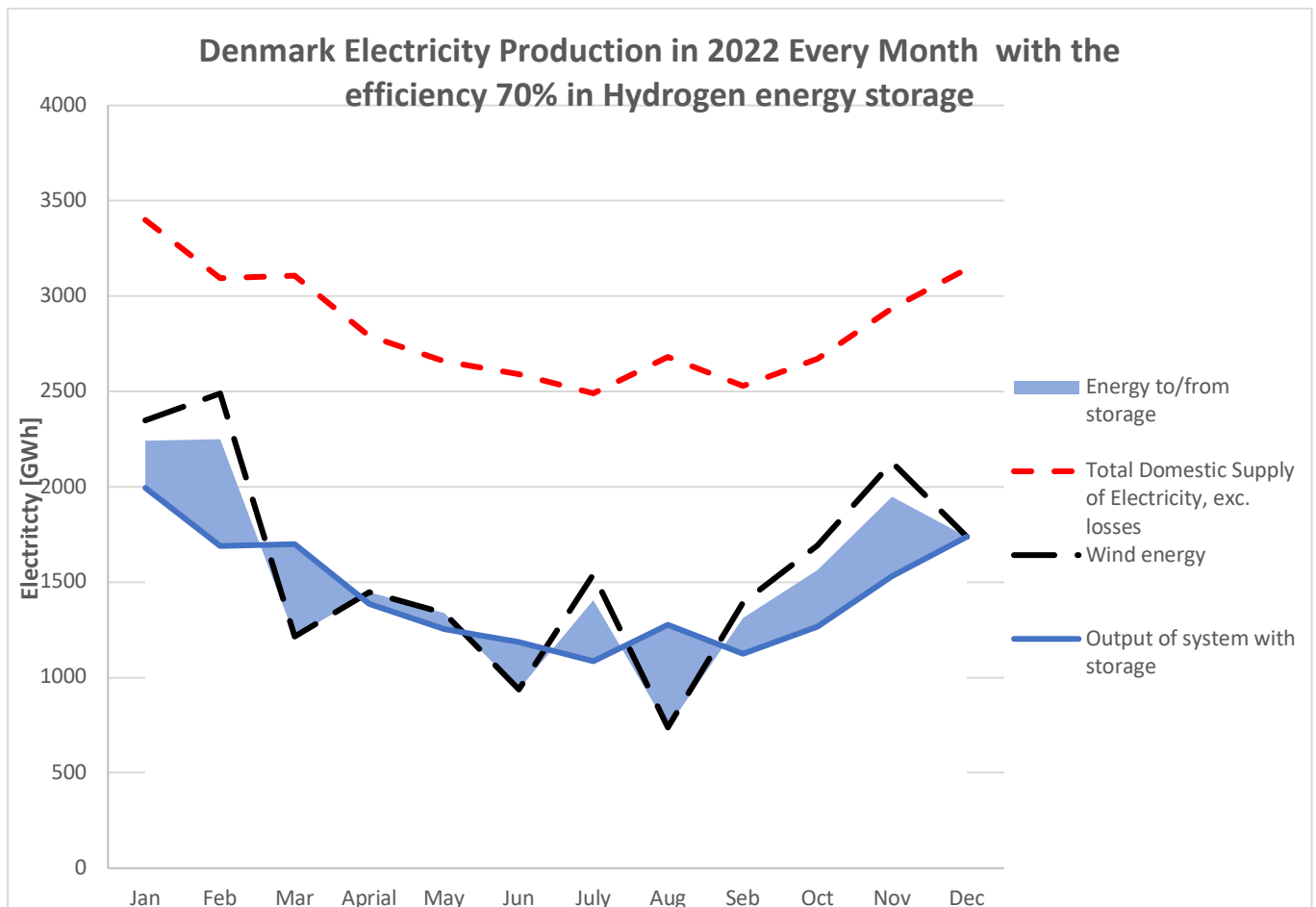

Figure 24 Denmark electricity production in 2022 every month including the Hydrogen storage. (32)

*Table 9 The differences between Wind production and output from the storage and the actual state of charge of the Hydrogen storage. (32)*

Months	Energy from/to storage [GWh]	Energy to storage including its efficiency /from storage [GWh]	Energy in the storage [GWh]
Jan	352.7	246.9	246.9
Feb	799.2	559.4	806.3
Mar	-485.3	-485.3	321.0
Aprial	60.9	60.9	381.9
May	82.8	82.8	464.7
Jun	-247.6	-247.6	217.1
July	456.8	319.8	536.9
Aug	-536.7	-536.7	0.1
Seb	268.3	187.8	188.0
Oct	427.3	299.1	487.1
Nov	596.8	417.8	904.8
Dec	-0.3	-0.3	904.6

The price cost to store 1KWh in Hydrogen storage cost 10\$(34). The maximum energy added to the storage in the year 2022 was in November and can be found in the table of added accumulation storage as 904.8 GWh. The investment cost for a lead-acid battery storage of such capacity will be \$ 9 048 440 888.56.

### **6.3. Denmark Electricity Production for one week between 1-8/08/2022**

This chart is created t to show the variation of wind energy and energy demand in one week. We can see that sometimes the wind energy even exceeds the total demand of energy and the output of the system with storage During these periods of high wind power generation there is a need for an accumulation storage to store the energy and use it on other days where the wind energy production is low like on the date from 01-07 of August.

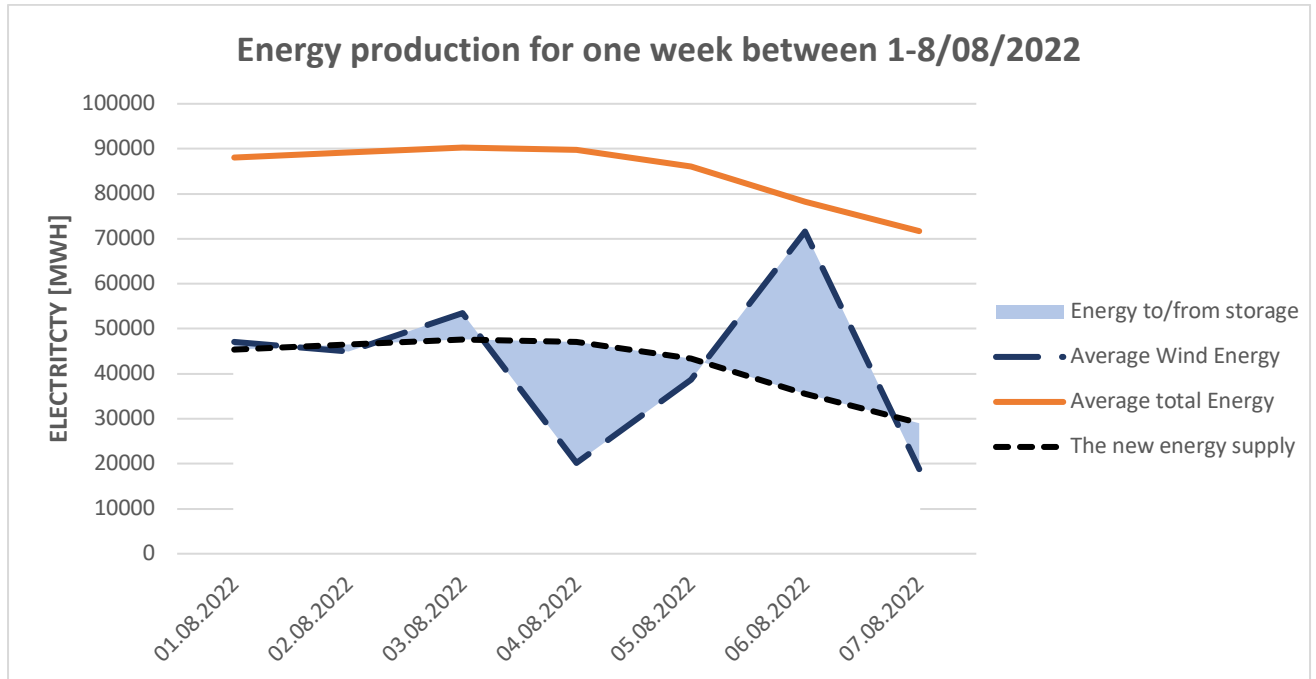

Figure 25 Denmark electricity production for one week between 1-8/08/2022 (35)

Table 10 Data of Denmark electricity production in the first week of August 2022 (35)

Date	Average total Energy [MWh]	Average wind energy [MWh]	Output of system with storage [MWh]	Energy to /from storage [MWh]
01.08.2022	88096.7	47074.8	45428.9	1645.9
02.08.2022	89200.2	44972.2	46532.4	-1560.15
03.08.2022	90273.9	53449.0	47606.1	5842.8
04.08.2022	89697.6	20117.4	47029.85	-26912.4
05.08.2022	86082.9	38620.2	43415.1	-4794.8
06.08.2022	78264.4	71600.0	35596.6	36003.3
07.08.2022	71702.7	18810.2	29034.9	-10224.7

The maximum capacity needed to be stored in the accumulation storage is 36003.3 MWh. If we use the LA-battery as the storage the total price of storing the energy will be \$ 240 302.7. If we use the Hydrogen storage the total price of storing the energy will be \$ 360 033.6. If you only utilize weekly capacity in the yearly balance, it signifies that we are considering a system's capacity on a weekly basis for the entire year.

An annual balance is used for planning or budgeting purposes, and it calculates and allocates resources based on the predicted capacity for the full year. This could include seasonal variations, peak demand periods, and overall patterns.

Using only the weekly capacity may result in resource underutilization or overutilization during specific times of the year. For instance, if weekly capacity is lower than typical

demand during peak seasons, you may encounter shortages or delays in meeting client requests. On the other side, if weekly capacity is greater than average demand during low seasons, you may have excess capacity that is not being used efficiently, resulting in higher expenses.

For more accurate resource allocation and planning, it is generally advised to account annual variations and swings in capacity while creating an annual balance.

## 7. Economic evaluation

In this section, a graph representing monthly electricity prices for the year 2022 will be provided. The goal is to determine whether using the hydrogen and lead-acid storage systems within their specified lives would allow for a break-even or profit when selling electricity to consumers or for domestic use in Denmark.

We will evaluate the financial sustainability of storage investments by comparing power pricing data with predicted earnings from storage systems over their separate lifetimes. The idea is to see if the accumulated earnings from selling power can cover the initial investment expenditures and potentially create profits.

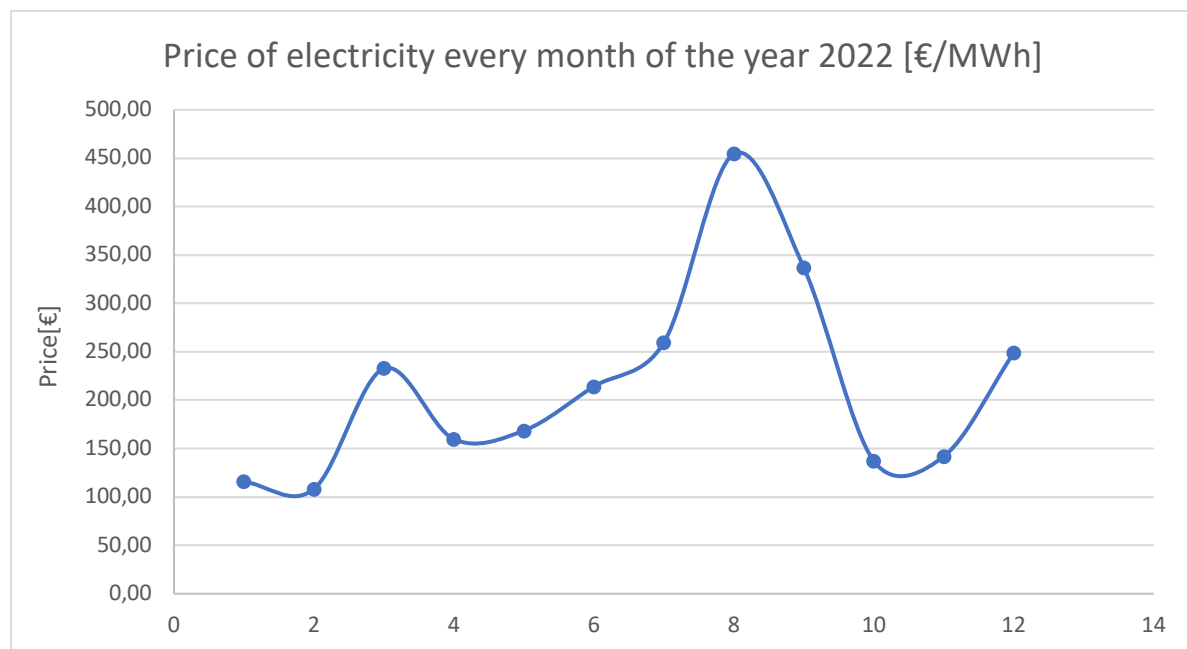

Figure 26 Price of electricity every month of the year 2022 (28)

The correlation between the price chart (Figure 26) and the electricity production chart (Figure 22) for Denmark in 2022 indicates a relationship. When wind energy is stored in the accumulation system, the price of electricity tends to be lower. Conversely, when electricity needs to be discharged from the accumulation system to meet demand, the price of electricity

tends to be higher. This observation suggests a connection between the availability of stored wind energy and its impact on electricity prices.

It can be inferred that the fluctuations observed in the more recent data, as depicted in (Figure 26), may be attributed to other underlying reasons beyond the variability in power generation alone. Factors such as geopolitical events, such as the war in Ukraine and natural gas crises, can have a substantial impact on energy markets and subsequently influence electricity prices. It is worth mentioning that these exceptional circumstances can lead to atypical price fluctuations that may not reflect the general trend observed in other years.

*Table 11 Price of electricity every month of the year 2022 (28)*

Months	Price every month [€]	The price of LA-battery storage every month [€]	The price of Hydrogen storage every month [€]
Jan	115.64	-30644600	-28551516
Feb	108.21	-67317441	-60532674
Mar	232.72	117942496	112939016
April	159.66	-6290604	-9723294
May	168.51	-10329663	-13952628
Jun	214.16	57630456	53026016
July	259.55	-90375310	-83004090
Aug	454.45	253673990	243903315
Seb	336.76	-66510100	-63243528
Oct	137.08	-44496168	-41000628
Nov	141.92	-65325776	-59294176
Dec	248.97	5427546	74691

In my thesis, I have considered the lifetime of a lead-acid (LA) battery to be 10 years to maximize its utilization. Based on this assumption, the total earnings from utilizing the LA battery storage in a single year if found using: sum of energy gained by discharging the storage from the LA-battery  $\times$  price in corresponding month – sum of energy going to the storage including its efficiency  $\times$  price in corresponding month. The amount is found to be **€ 53 384 826.00** Multiplying this annual earning by the battery's assumed lifetime of 10 years results in a total earning of **€ 533 848 260.00** over the given period.

However, it is worth noting that the total earning of € 533 848 260.00 falls significantly short of the price of the LA battery, which is valued at \$88,582,686,039.34. This substantial difference highlights the cost disparity between the battery investment and the total earnings generated over its projected lifetime.

I have considered the lifetime of a hydrogen storage system to be 30 years in order to maximize its utilization. Under this assumption, the total earnings from utilizing the hydrogen storage system in a single year amount to € 50 640 504.00 . Multiplying this annual earning by the storage system's assumed lifetime of 30 years results in a total earning of € 1 519 215 120.00 over the given period.

However, it is important to note that the total revenues of €1,519,215,120.00 do not exceed the initial investment cost of the hydrogen storage system, which is €9,048,440,888.56. This suggests that the earnings may not be adequate to pay the total cost of the storage system, let alone produce a profit.

It is critical to analyze the effects of various boundary conditions, such as electricity prices, storage system investment costs, and efficiency, on the results produced. Sensitivity analysis can assist in identifying the essential parameters that have a major impact on the economic viability and profitability of energy storage. It is feasible to examine the resilience and sensitivity of the results to changes in the operating environment by systematically adjusting these factors and analyzing their influence on the outcomes.

For example, if electricity prices fluctuate significantly or rise over time, the revenue earned by energy storage devices may benefit. Higher electricity costs would increase the value of stored energy during peak demand periods, improving the economic viability of accumulation systems.

Similarly, if investment costs for storage systems fall as a result of technological breakthroughs or economies of scale, the overall profitability of accumulation will improve. Lower initial investment costs would reduce the payback period and raise the possibility of attaining a positive return on investment throughout the lifespan of the storage system.



Furthermore, improvements in storage system efficiencies can help to improve the economic viability of accumulation. Higher efficiency would improve energy use and revenue generation, allowing for more efficient storage technology adoption.

The Danish government has established a long-term goal of achieving energy self-sufficiency through renewable sources by 2050. According to estimates, lead-acid (LA) battery costs might fall to \$35/kWh in 2050 (36), while the cost of storing hydrogen may reduce to \$0.5/kWh (37). The cost of LA battery storage is expected to fall from **\$88,582,686,039.34** to **\$34,448,822,348.63** assuming similar efficiencies, storage lifetimes, and electricity prices as in 2022. Although this is a significant reduction, it is still significantly higher than the total earnings of **€533,848,260.00** over the lifetime of the LA battery.

In contrast, the cost of hydrogen storage systems is projected to decrease from **\$9,048,440,888.56** to **\$452,422,044.43**, indicating a substantial decrease. Furthermore, the total earnings of **€1,519,215,120.00** over the system's lifetime suggest that the hydrogen storage system can achieve a breakeven point and generate profits.

## **8. Conclusion**

Finally, power accumulation is critical in tackling the issues associated with intermittent renewable energy sources and fluctuating electricity demand. The incorporation of renewable energy, such as wind and solar power, has become increasingly crucial as the globe transforms to a greener and more sustainable energy landscape. However, the inherent fluctuation of renewable sources creates challenges in maintaining a steady and consistent electrical supply.

My thesis investigated the economic feasibility and profitability of using lead-acid (LA) batteries and hydrogen storage systems for energy storage. Important insights have been acquired from analysing their distinct lifetimes and incomes.

Regarding the use of LA batteries, the total revenues during the provided period were determined to be **€533,848,260.00** based on a lifetime of 10 years. However, this is substantially less than the cost of the LA battery itself, which is valued at **\$88,582,686,039.34**. The considerable discrepancy between earnings and the cost of the

battery highlights the significant investment required and the difficulty in recouping the expenses.

The use of hydrogen storage devices, on the other hand, yielded total revenues of **€1,519,215,120.00** during the provided period, assuming a lifetime of 30 years. Despite exceeding the annual revenues of the LA batteries, the earnings do not exceed the initial investment cost of the hydrogen storage system, which is **€9,048,440,888.56**. This suggests that, while earnings are possible, they may not be adequate to cover the whole cost of the storage system.

The findings highlight the significance of performing a thorough analysis of the economic consequences of energy storage technologies. To ensure the financial viability and profitability of deploying energy accumulation technologies, it is critical to properly assess parameters such as longevity, initial investment cost, and possible revenues. Further research and analysis are required to investigate various methodologies and optimize economic outcomes, particularly in the rapidly changing environment of energy markets.

The research findings serve as a guide for navigating the path towards a sustainable and economically viable energy future. Moreover, the study highlights the economic advantages of hydrogen storage systems when compared to lead-acid batteries, particularly in terms of cost-effectiveness and profitability. As the Danish government pursues its renewable energy goals, it becomes increasingly important to investigate and assess different ways to energy storage that can provide realistic and economically viable solutions.

## Reference

1. Renewable Energy. Online. [Accessed 28 September 2022]. Available from: <https://www.energy.gov/eere/renewable-energy>
2. Wide observation to renewable energy sources. Online. [Accessed 15 June 2023]. Available from: [https://www.researchgate.net/publication/355433390\\_Effect\\_of\\_wide\\_observation\\_of\\_nature\\_in\\_renewable\\_energy\\_engineering\\_education/figures?lo=1](https://www.researchgate.net/publication/355433390_Effect_of_wide_observation_of_nature_in_renewable_energy_engineering_education/figures?lo=1)
3. HOSSEIN KARAMI LAKEH. What Are the Advantages and Disadvantages of Renewable Energy. Online. 20 May 2022. [Accessed 2 October 2022]. Available from: <https://www.greenmatch.co.uk/blog/2021/09/advantages-and-disadvantages-of-renewable-energy>
4. JOHN TWIDELL AND TONY WEIR. *Renewable Energy Resources*. . Third. 2015.
5. WEI TONG. *Wind Power Generation and Wind Turbine Design*. . 2010.
6. Wind Concept, Causes & Characteristics. Online. 21 January 2022. [Accessed 29 September 2022]. Available from: <https://study.com/academy/lesson/what-is-wind-definition-causes-properties-characteristics.html>
7. Wind Map of Denmark. Online. 1 June 2003. [Accessed 29 September 2022]. Available from: <http://www.drømstørre.dk/wp-content/wind/miller/windpower%20web/en/tour/wres/dkmap.htm>
8. VERTICAL AXIS WIND TURBINE PARTS. Online. [Accessed 2 October 2022]. Available from: <https://www.green-mechanic.com/2013/03/vertical-axis-wind-turbine-parts.html>
9. ISABELLA HASSALL. Storage technologies. Online. 29 May 2015. [Accessed 25 January 2023]. Available from: <https://www.smsglobal.com/blog/clean-energy-battery-life/>
10. MUKUND R. PATEL. *Wind and Solar Power Systems Design, Analysis, and Operation*. . Second. 2006.
11. Pumped Storage Hydropower. Online. [Accessed 27 January 2023]. Available from: <https://www.bv.com/industries/hydropower-hydraulic-structures/pumped-storage-hydropower>
12. Wendenfurth Pumped-storage Power Plant. Online. [Accessed 1 February 2023]. Available from: <https://powerplants.vattenfall.com/wendenfurth/>
13. NICLAS. Compressed Air Energy Storage. Online. [Accessed 11 June 2023]. Available from: <https://sinovoltaics.com/learning-center/storage/compressed-air-energy-storage/>
14. YOGI GOSWAMI. *Energy Efficiency and renewable energy handbook*. . Second. 2016.
15. B. ZOHURI. LA battery. Online. [Accessed 11 June 2023]. Available from: <https://www.sciencedirect.com/topics/agricultural-and-biological-sciences/lead-acid-battery>.
16. The best uses for nickel cadmium (Ni-Cd) batteries. Online. 14 February 2022. [Accessed 29 May 2023]. Available from: <https://www.solarreviews.com/blog/best-uses-for-nickel-cadmium-batteries>
17. NAS Battery System. Online. [Accessed 2 March 2023]. Available from: <https://www.ngk-insulators.com/en/product/nas-configurations.html>
18. Flow battery energy storage . Online. [Accessed 5 March 2023]. Available from: <https://www.cei.washington.edu/education/science-of-solar/flow-battery/>
19. Flow batteries. Online. 28 September 2014. [Accessed 5 March 2023]. Available from: <https://wernerantweiler.ca/blog.php?item=2014-09-28>

20. OVIDIU SANDRU. Flywheel. Online. 6 March 2015. [Accessed 10 May 2023]. Available from: <https://www.greenoptimistic.com/how-to-plan-an-eco-friendly-vacation-20210331/>
21. KEITH R. PULLEN. Flywheel energy storage. Online. 2022. [Accessed 10 March 2023]. Available from: <https://www.sciencedirect.com/topics/engineering/flywheel-energy-storage>
22. Hydrogen storage. Online. [Accessed 12 June 2023]. Available from: <https://www.eagleburgmann.com/en/energy-transition/hydrogen/hydrogen-storage>
23. Pumped Storage Station. Online. [Accessed 12 June 2023]. Available from: [https://en.wikipedia.org/wiki/Bath\\_County\\_Pumped\\_Storage\\_Station#:~:text=The%20Bath%20County%20Pumped%20Storage,storage%20capacity%20of%2024%2C000%20MWh.](https://en.wikipedia.org/wiki/Bath_County_Pumped_Storage_Station#:~:text=The%20Bath%20County%20Pumped%20Storage,storage%20capacity%20of%2024%2C000%20MWh.)
24. compressed air energy storage. Online. [Accessed 12 June 2023]. Available from: <https://www.pv-magazine-australia.com/2022/10/07/worlds-largest-compressed-air-energy-storage-project-goes-online-in-china/#:~:text=Technology%20and%20R%26D-,World%27s%20largest%20compressed%20air%20energy%20storage%20project%20goes%20online%20in,kWh%20of.>
25. NICK LAVARS. largest flow battery. Online. 22 August 2022. [Accessed 12 June 2023]. Available from: <https://newatlas.com/energy/worlds-largest-flow-battery-grid-china/>
26. T. YAMASHITA. Largest Flywheel storage. Online. 18 December 2015. [Accessed 12 June 2023]. Available from: <https://www.rtri.or.jp/eng/publish/newsletter/pdf/53/RTN-53-315.pdf>
27. largest hydrogen storage. Online. November 2021. [Accessed 12 June 2023]. Available from: <https://www.sciencedirect.com/science/article/abs/pii/S1464285921006027#:~:text=The%20world%27s%20largest%20hydrogen%20fuel,and%20heat%20an%20additional%2044%2C000>
28. Average monthly electricity wholesale price in Denmark from January 2019 to March 2023. Online. 2023. [Accessed 12 June 2023]. Available from: <https://www.statista.com/statistics/1271525/denmark-monthly-wholesale-electricity-price/>
29. JANIS ZVIRGZDINS. Advantages and disadvantages of Pumped Storage Hydropower Plants . . June 2020.
30. S. R. SALKUTI. Comparative analysis of storage techniques. Online. June 2018. [Accessed 12 June 2023]. Available from: [https://www.researchgate.net/publication/326056855\\_Comparative\\_analysis\\_of\\_storage\\_techniques\\_for\\_a\\_grid\\_with\\_renewable\\_energy\\_sources](https://www.researchgate.net/publication/326056855_Comparative_analysis_of_storage_techniques_for_a_grid_with_renewable_energy_sources)
31. E. KOONS. Pros and Cons of Hydrogen. Online. 9 February 2023. [Accessed 12 June 2023]. Available from: <https://energytracker.asia/pros-and-cons-of-hydrogen-energy/#:~:text=Hydrogen%20energy%20has%20many%20pros,in%20the%20global%20energy%20transition>
32. Electricity production and supply in Denmark . Online. [Accessed 12 June 2023]. Available from: <https://ens.dk/en/our-services/statistics-data-key-figures-and-energy-maps/annual-and-monthly-statistics.>
33. LA battery cost. Online. [Accessed 30 April 2023]. Available from: [https://www.ultralifecorporation.com/PrivateDocuments/WP\\_li-ion-vs-lead-acid-WEB\\_1](https://www.ultralifecorporation.com/PrivateDocuments/WP_li-ion-vs-lead-acid-WEB_1)
34. Hydrogen Storage price. Online. [Accessed 30 April 2023]. Available from: <https://www.energy.gov/eere/fuelcells/hydrogen-storage>
35. Electricity Balance for a week. Online. [Accessed 12 June 2023]. Available from: <https://www.energidataservice.dk/tso-electricity/ElectricityBalanceNonv>

36. JOHN HOWES. Advanced lead batteries and the \$35/kWh challenge. Online. 15 February 2022. [Accessed 15 June 2023]. Available from: <https://www.innovationnewsnetwork.com/advanced-lead-batteries-35-kwh-challenge/18269/>
37. WILLIAM DRISCOLL. Study backs hydrogen for long-duration storage. Online. 3 July 2020. [Accessed 15 June 2023]. Available from: <https://pv-magazine-usa.com/2020/07/03/nrel-study-backs-hydrogen-for-long-duration-storage/>