

**A (2:1)**

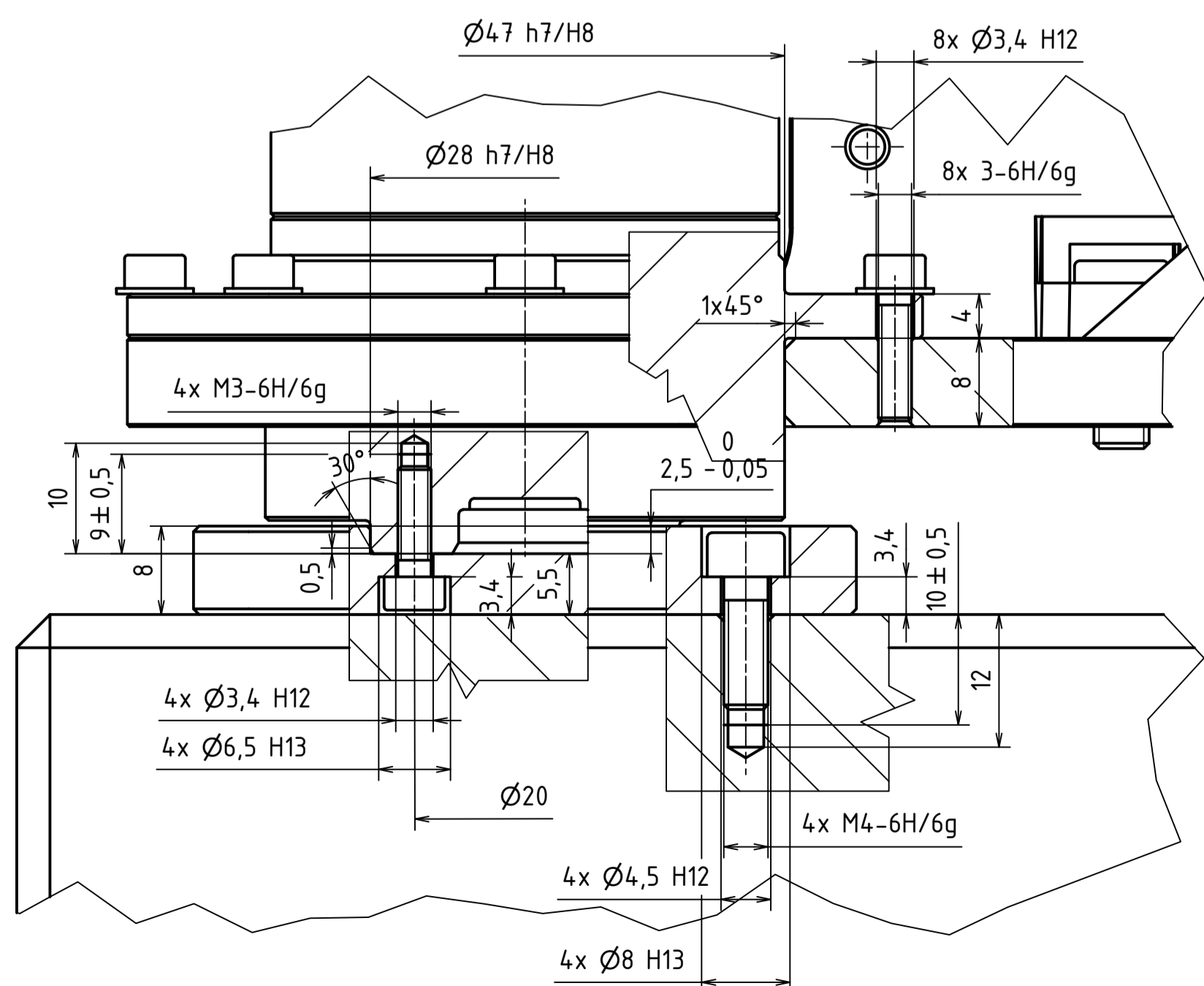

**B (1:1)**

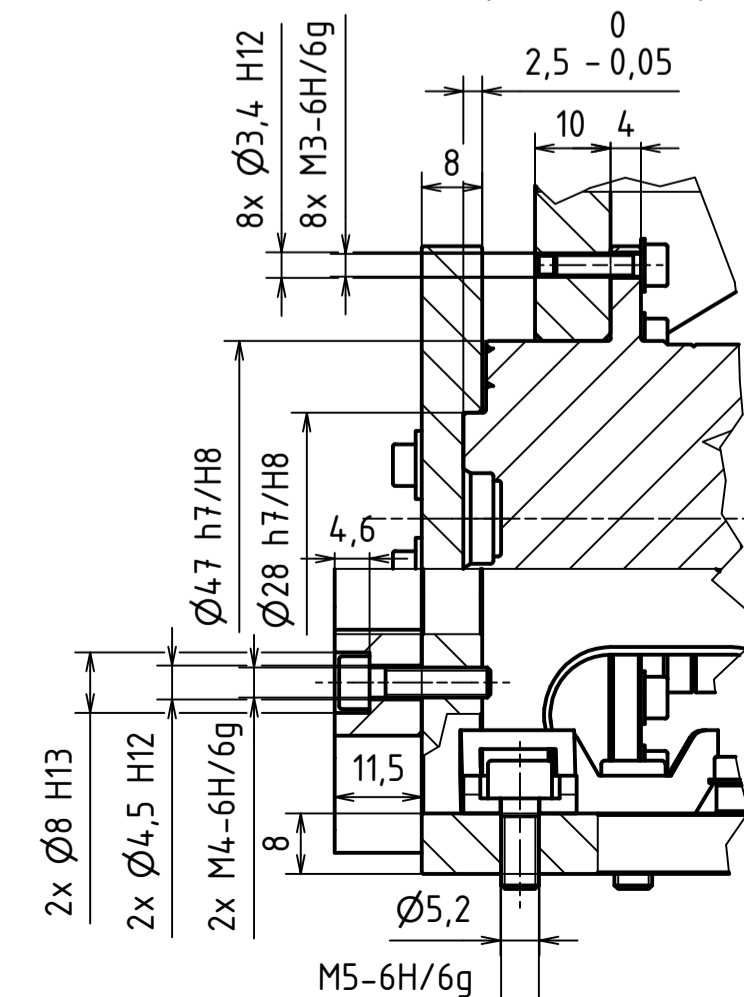

**D (1:1)**

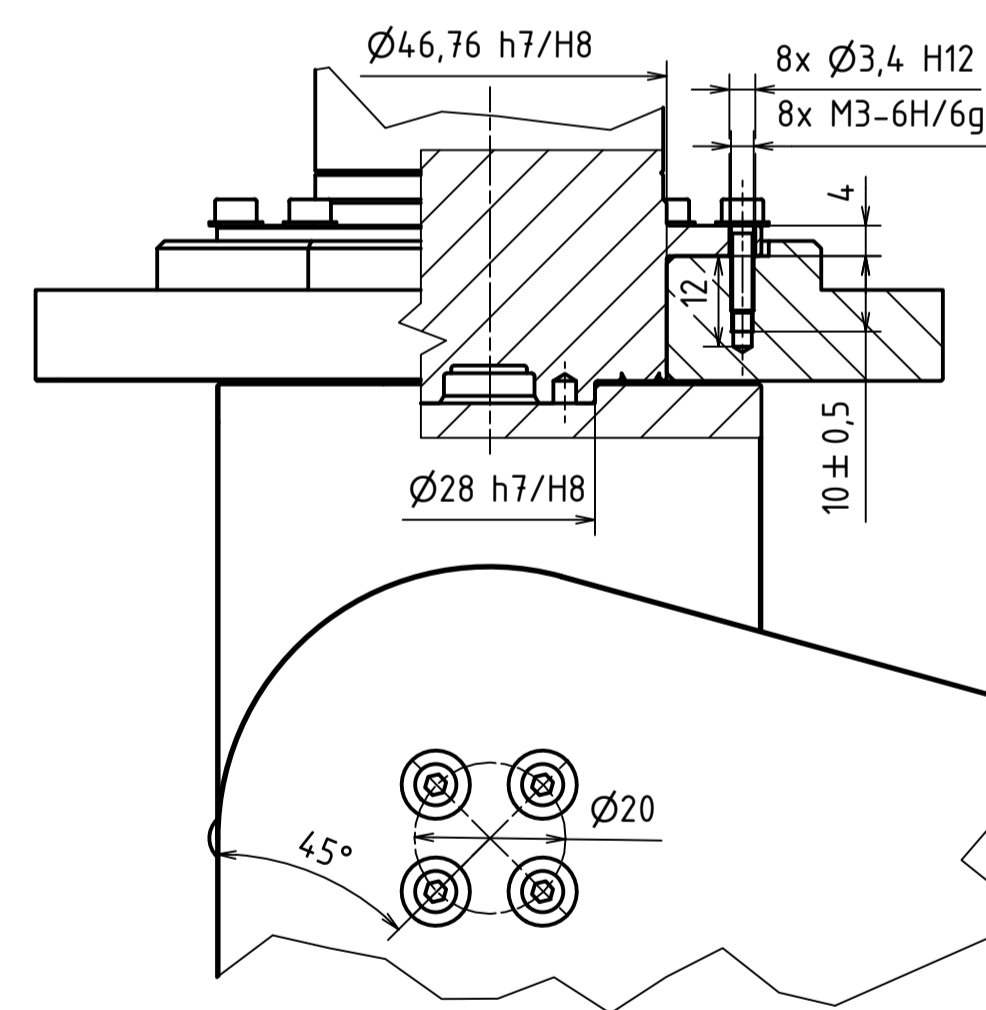

**E (1:1)**

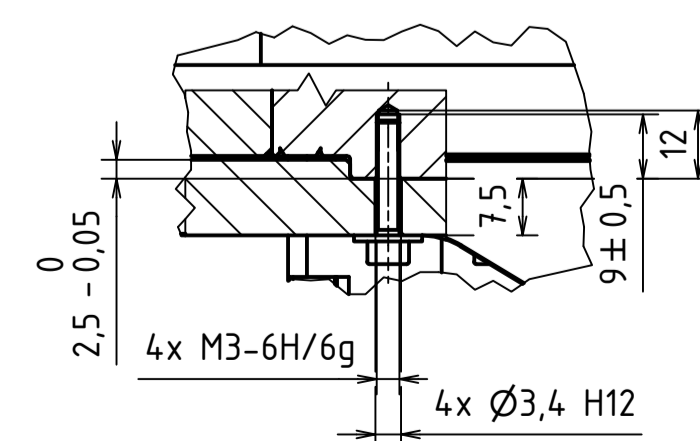

**C (1:1)**

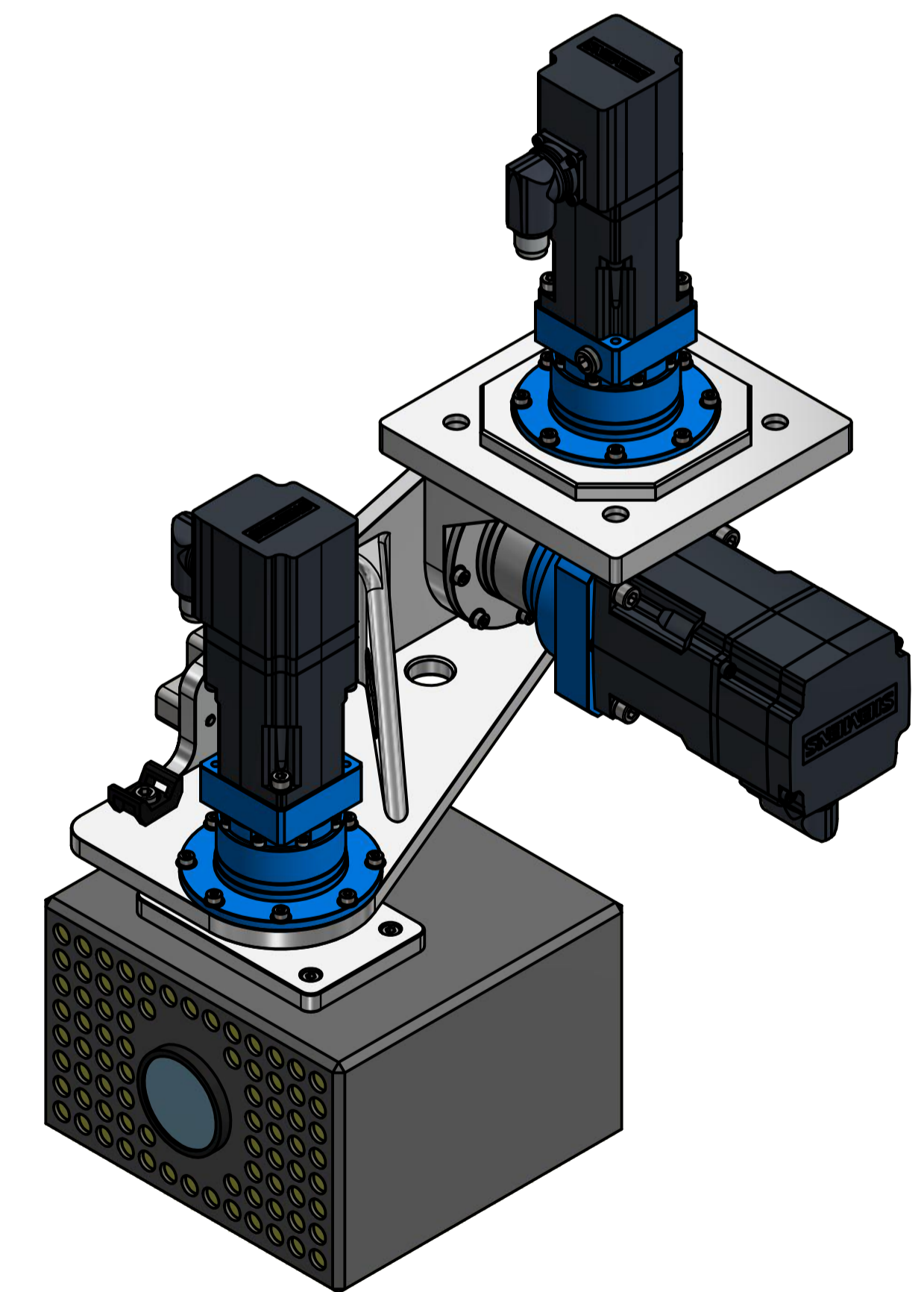
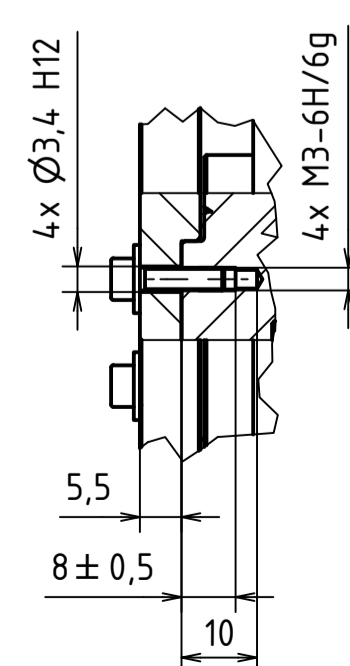

VŠECHNY ŠROUBOVÉ SPOJE ZALEPIT POMOCÍ LOCTITE 243							
NAVBH. MAREK ŠTOSK	Autur	Datum	PRŮŽK	Podpis	Datum	HPOTNOST Není k dispozici	MEŘITVO
KRESLIL MAREK ŠTOSK		21.02.2022	SCHVÁLIL		15.03.2022	SESTAVA DP-01-01-01	1:2,1/2:1
						KUSOVNÍK DP-01-01-01K	PROJITÁN 1:50 E.1
							TP
ČESKÉ VYSOKÉ UČENÍ TECHNICKÉ V PRAZE		FAKULTA STROJNÍ		NAZEV		PODSESTAVA ROTAČNÍCH OS MANIPULÁTORU	
				ČÍSLO VÝKRESU		DP-01-02-01	
LIST: 1/1							