

1

2

3

4

A

A

A-A

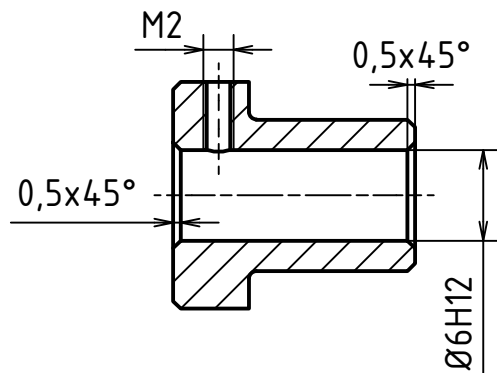

B

B

C

C

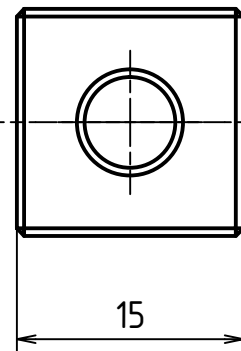
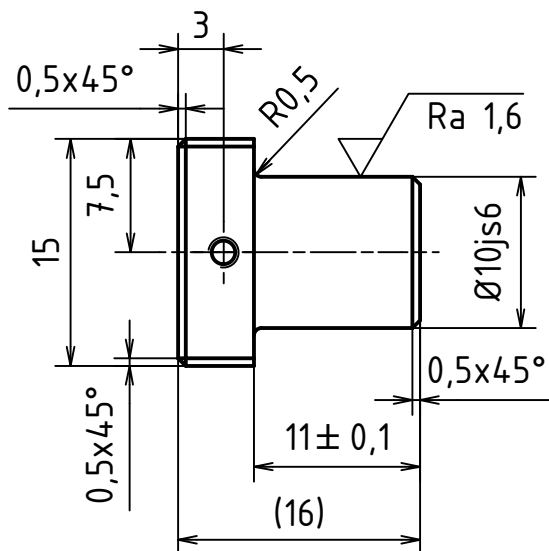

D

D

E

E

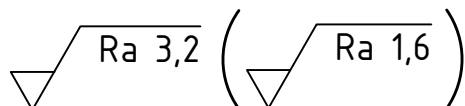

MATERIAL: EN 573-3

POLOTOVAR: Tyč čtvercová ČSN 42 1419 - 15 - 17

TOLEROVÁNÍ DLE ISO 8015

PŘESNOST ISO 2768 - mK

VŠEOB. TOL. ISO 8062 -

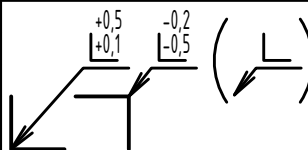

INDEX

ZMĚNA

DATUM

PODPIS

Autor		Datum		Podpis		Datum		HMOTNOST 0,012 kg		MĚŘÍTKO	
NAVRHL	Bui	06.03.2021	PREZK.						SESTAVA	2:1	
KRESLIL	Bui	27.07.2021	SCHVALIL						KUSOVNÍK	PROMÍTÁNÍ: $\begin{matrix} \square \\ \oplus \end{matrix}$ (ISO E.)	

F

F

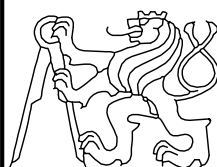

ČESKÉ
VYSOKÉ
UČENÍ
TECHNICKÉ
V PRAZE

FAKULTA
STROJNÍ

NÁZEV

POUZDRO

ČÍSLO VÝKRESU

BP-001-02

LIST: 1 /

1

2

3

4