

Konfigurace pro uchopení rotačního dílce

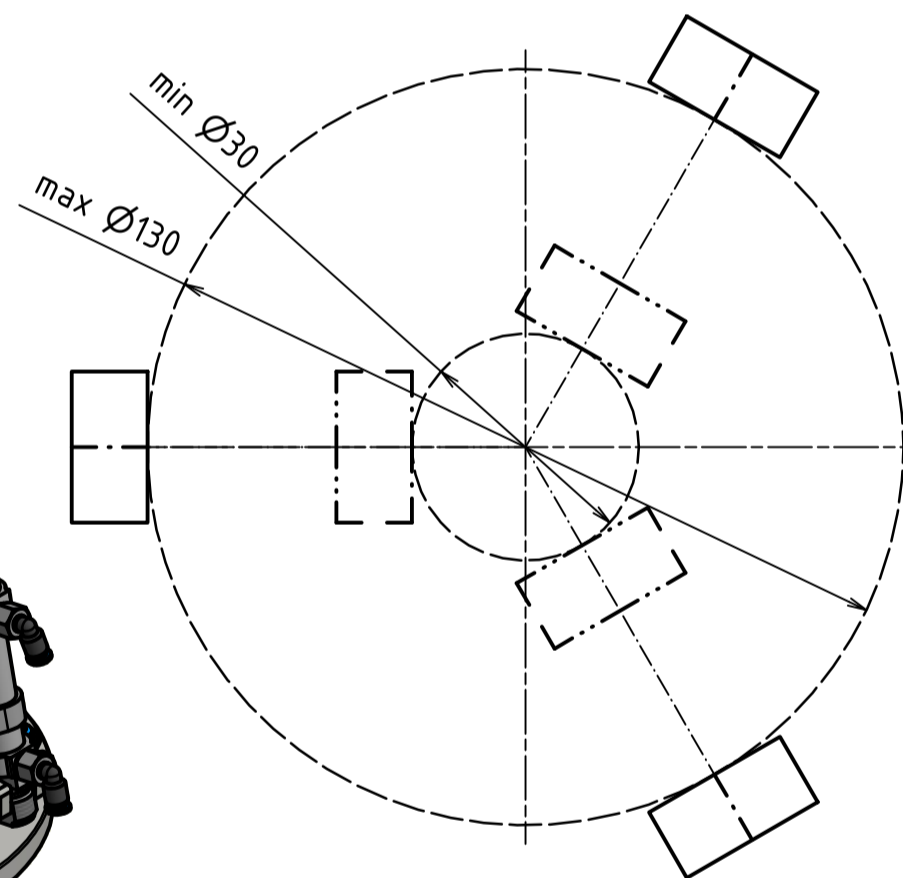

Konfigurace pro uchopení prizmatického dílce

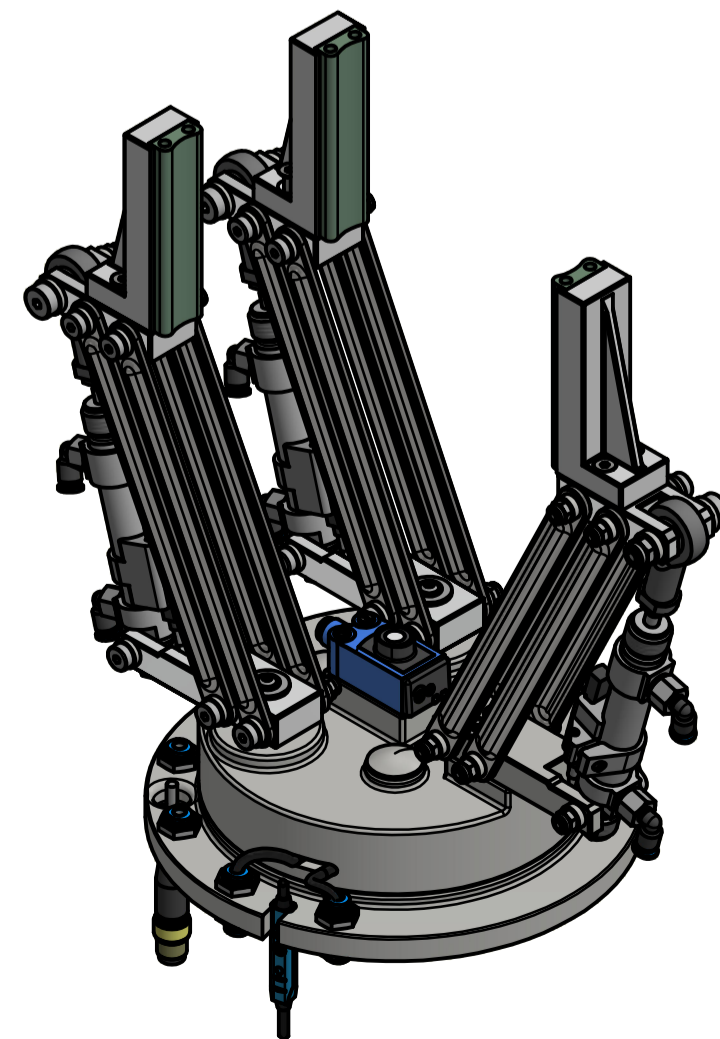
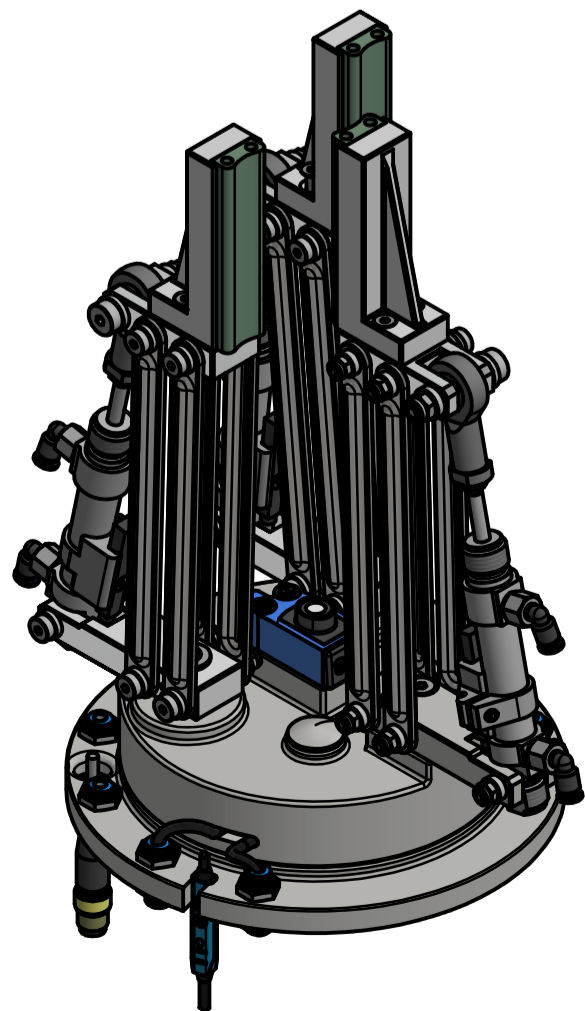
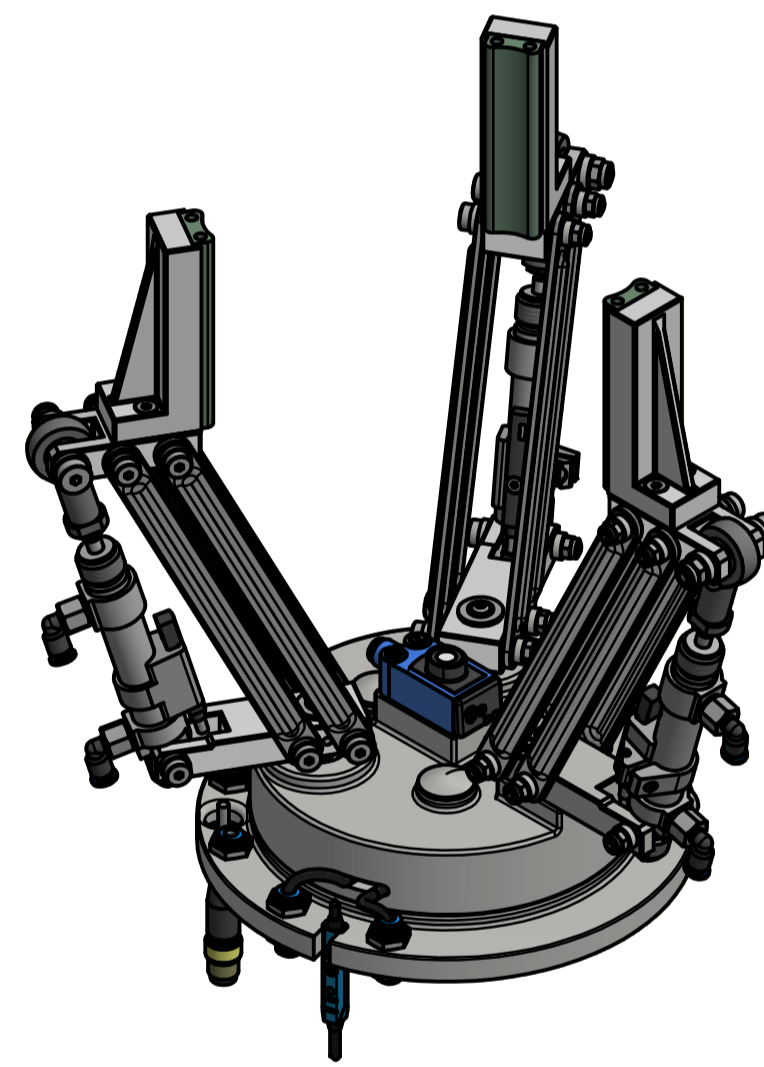
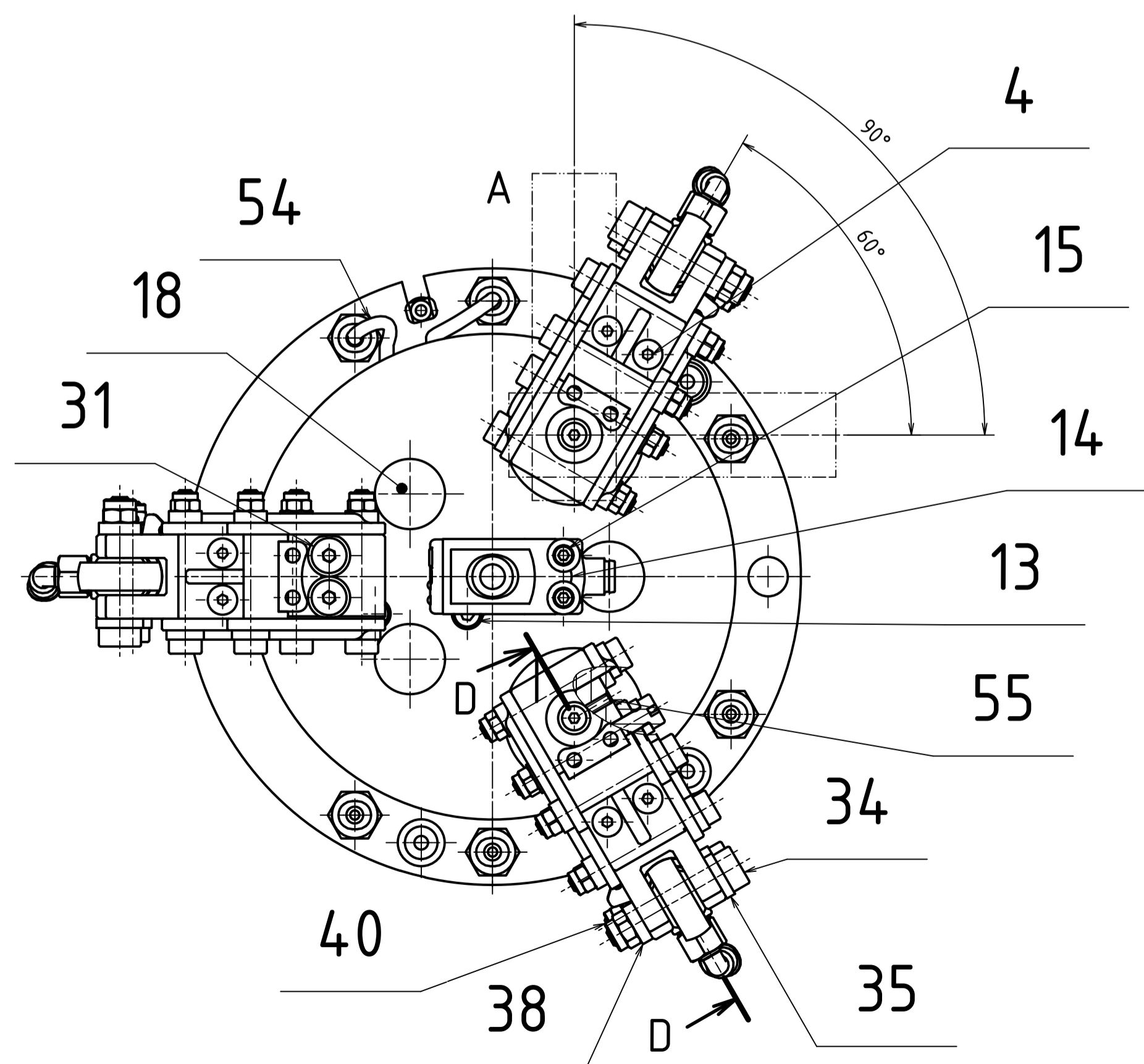
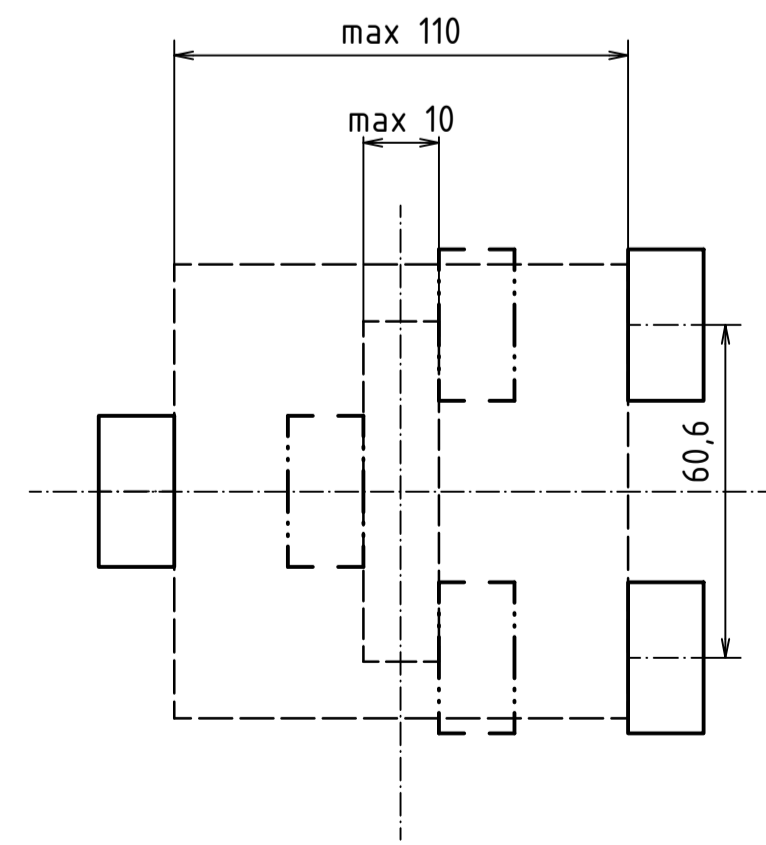

9 E (5 : 1)

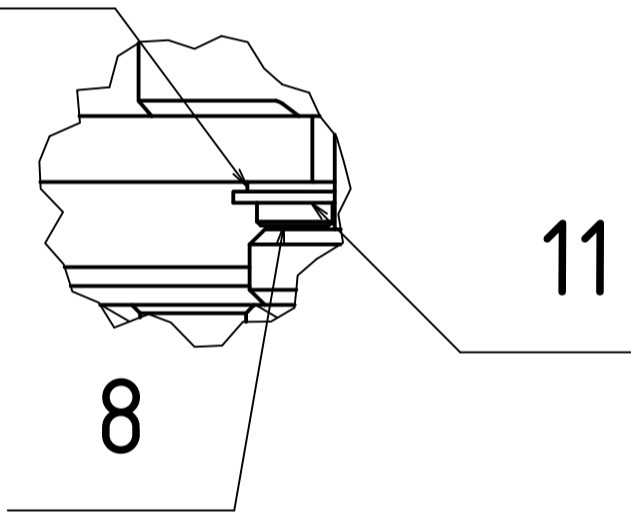

F (5 : 1)

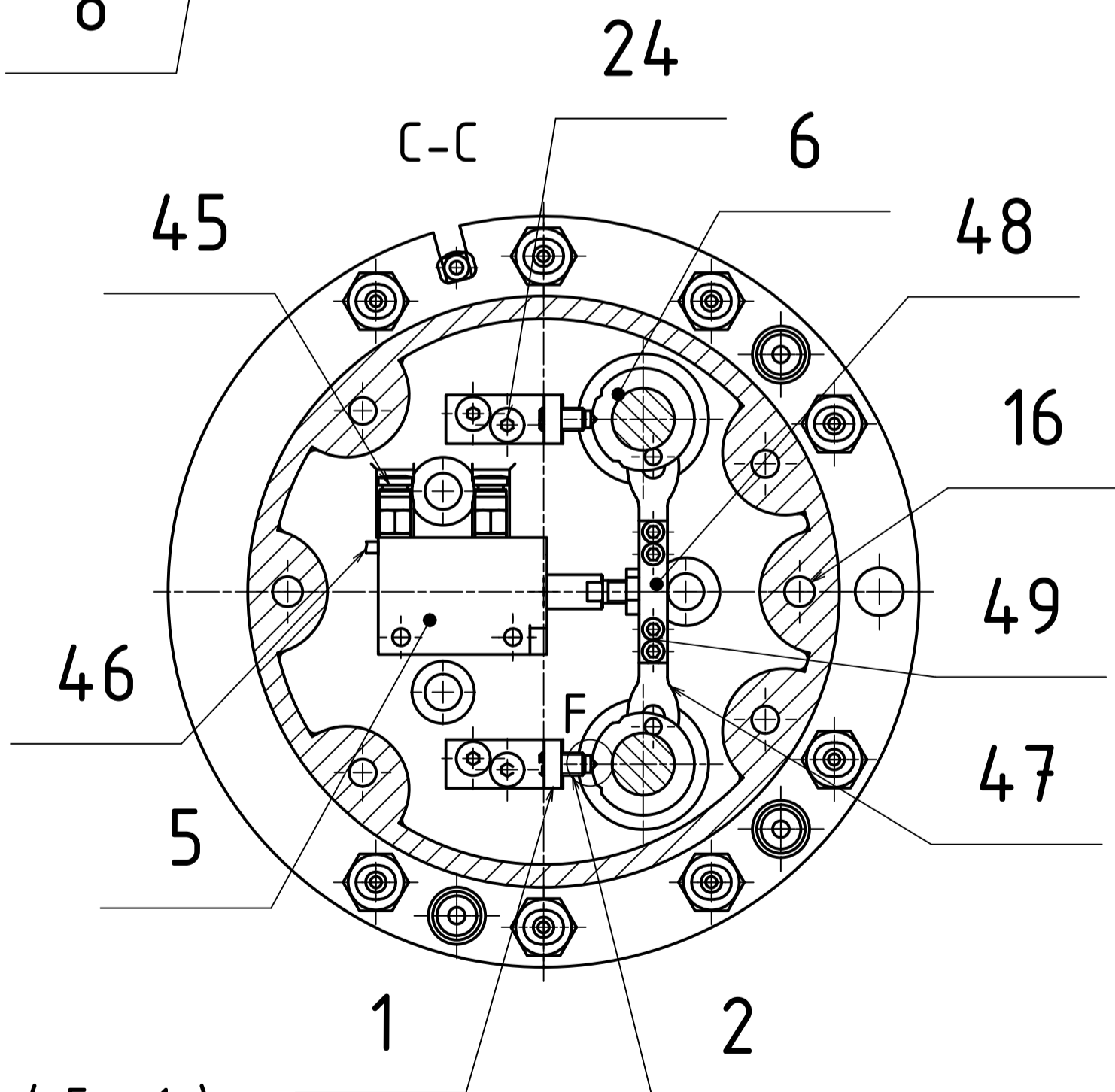
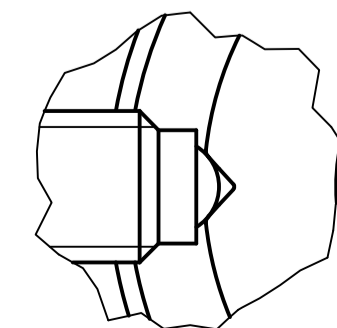

NAVŠEH KRESLÁK	Jaroslav Sedlář	Datum 09.06.2021	PŘEZK SCHVAİL	Podpis	Datum	HMOTNOST 2,532 kg	MEŘITVO 1:1 (1:X)
						SESTAVA KUSOVNIK BP0276-2021-K001	PROJITAN ISO E 1
ČESKÉ VYSOKÉ UČENÍ TECHNICKÉ V PRAZE		FAKULTA STROJNÍ		NAZEV Uchopovací hlavice		ČÍSLO VÝKRESU BP0276-2021-1001	
LIST: 1 / 1							