

Electro-Magnetic Single Disc Clutch

Characteristics

- Electrically operated 12, 24, 103,5 VDC
- Single friction face
- Activated by power on

Utilisation

- Coupling of a pulley or a shaft

Particularities

- No backlash
- For dry use
- No residual torque in disengaged position
- Fixed OM inductor

Adjustments

- Airgap "P" should be adjusted at installation
- Requires wear compensation

Maintenance Manual

- SM 304

Mounting Precautions

- Centre the inductor
- Observe dimension "M"
- Device intended for horizontal or vertical use

Power Supply

- For 24 volts versions only :
 CBC 400-24 - CBC 450-24
 CBC 500-24 - CBC 550-24
 CBC 700 (overexcitation)
 CBC 140-5 + CBC 140-T (24V)
 CBC 140-5 (103,5V)

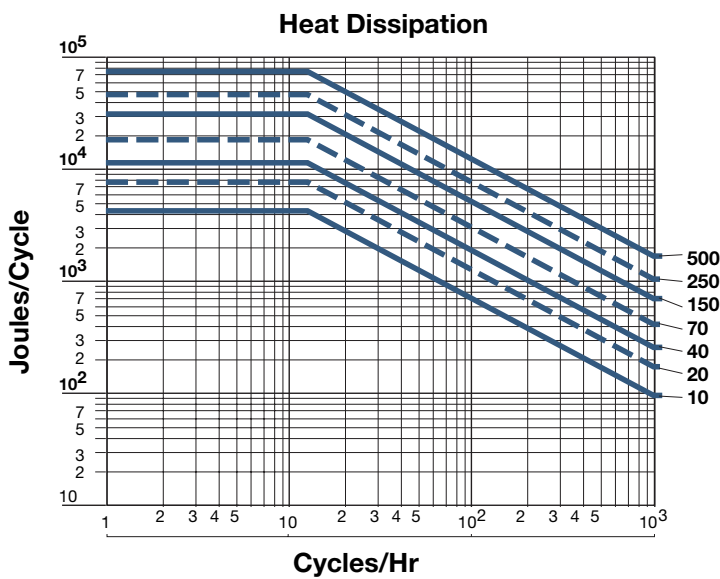

Electro-Magnetic Single Disc Clutch

**EUROstandard
Indirect Drive**

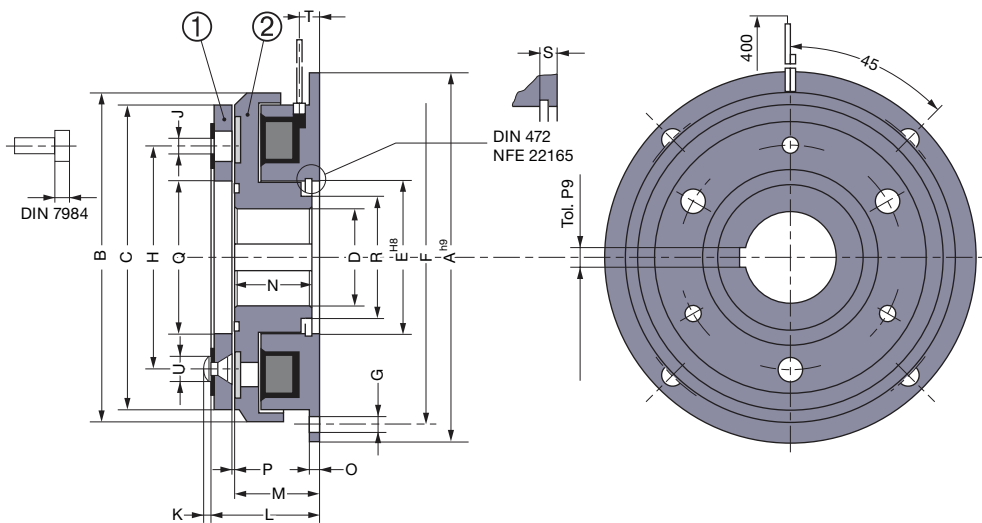

Sizes		10	20	40	70	150	250	500
Nom. Torque	[Nm]	7	15	30	60	120	250	500
Max. Speed	[min ⁻¹]	8000	6000	5000	4000	3000	3000	2000
Power	P20[U=12/24/103,5V] [W]	12,5	17	27	31	44	59	83
	A	80	100	125	150	190	230	290
	B	68	86	107	134	170	213	267
	C	63	80	100	125	160	200	250
	D min	10H8	10H8	14H8	14H7	20H7	25H7	25H7
	D Std	10/15/17	10/17/20	20/25/30	25/30/35	30/40/45	40/50/60	50/60/80
	D max	17H8	22H8	30H8	40H7	50H7	65H7	80H7
	E	35	42	52	62	80	100	125
	F	72	90	112	137	175	215	270
	G For screw	4xM4	4xM5	4xM6	4xM6	4xM8	4xM8	4xM10
	H	46	60	76	95	120	158	210
	J (1) For screw	3xM3	3xM4	3xM5	3xM6	3xM8	3xM10	4xM12
	K	1,5	1,5	2,5	3	3	3	5
	L	28	31	36	40,5	46,5	55,5	64
	M	24	26,5	30	33,5	37,5	44	51
	N	22	24	27	30	34	40	47
	O	2	2,5	3	3,5	4	5	6
	P	0,2	0,2	0,2	0,3	0,3	0,5	0,5
	Q	35	41	52	62	80	100	125
	R	23	28,5	40	45	64	77	100
	S	3,5	4,3	5	5,5	6	7	8
	T	5,6	6,5	9	9,5	11	10	12
	U	6	6	10	12	12	17	20
Inertia	① [kgm ²]	0,00004	0,00012	0,0005	0,0013	0,0049	0,0140	0,0360
Inertia	② [kgm ²]	0,00011	0,00027	0,0008	0,0022	0,0065	0,0195	0,0550
Weight	[kg]	0,5	0,9	1,7	3	5,5	10	18,5
Connection		Leads			Cable			

Connector Options

(Delivered without cable)

2 poles, capacity : 0,5/2,5mm²



Keyway according to ISO R773 / BS 4235 / DIN 6885-1 / NFE 22-175, tolerance P9 (1) Armature, Fixing "J" by screws DIN7984 (not provided)