

Bachelor's thesis

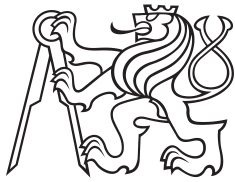

**Czech
Technical
University
in Prague**

F3

**Faculty of Electrical Engineering
Department of Control Engineering**

Motor controller configuration for use in electric formula powertrain

Michal Kopiar

**Supervisor: Ing. Vít Hlinovský, CSc
Supervisor–specialist: Ing. Stanislav Tomášek
Field of study: Cybernetics and Robotics
May 2021**

I. Personal and study details

Student's name: **Kopiar Michal** Personal ID number: **483680**
Faculty / Institute: **Faculty of Electrical Engineering**
Department / Institute: **Department of Control Engineering**
Study program: **Cybernetics and Robotics**

II. Bachelor's thesis details

Bachelor's thesis title in English:

Motor controller configuration for use in electric formula powertrain

Bachelor's thesis title in Czech:

Konfigurace frekvenčního měniče pro trakční motory elektrické formule

Guidelines:

- 1) Investigate commercially available electric motors viable for use in the tractive system of electric formula.
- 2) Perform configuration of provided tractive motor controller for selected motors based on the available documentation.
- 3) Measure and validate the parameters of the selected motor.
- 4) Discuss further possible directions of powertrain development in the eForce Formula Student team.

Bibliography / sources:

- 1) PYRHONEN Juha, Tapani JOKINEN, Valeria HRABOVCOVÁ - Design of rotating electrical machines - Hoboken, NJ, 2008
- 2) LEONHARD Werner - Control of electrical drives. 3rd ed - New York, 2001

Name and workplace of bachelor's thesis supervisor:

Ing. Vít Hlinovský, CSc., Department of Electric Drives and Traction, FEE

Name and workplace of second bachelor's thesis supervisor or consultant:

Date of bachelor's thesis assignment: **28.01.2021** Deadline for bachelor thesis submission: _____

Assignment valid until: **30.09.2022**

Ing. Vít Hlinovský, CSc.
Supervisor's signature



prof. Ing. Michael Šebek, DrSc.
Head of department's signature



prof. Mgr. Petr Páta, Ph.D.
Dean's signature

III. Assignment receipt

The student acknowledges that the bachelor's thesis is an individual work. The student must produce his thesis without the assistance of others, with the exception of provided consultations. Within the bachelor's thesis, the author must state the names of consultants and include a list of references.

Date of assignment receipt

Student's signature

Acknowledgements

This thesis could not originate without the help of my colleagues, friends and family.

I would like to thank my supervisor Ing. Vít Hlinovský, CSc. for sharing his valuable expertise in this field and providing me with consultations and irreplaceable feedback.

I would also like to thank doc. Ing. Pavel Mindl, CSc. for providing and supervising testing in VTP Roztoky laboratories.

Special thanks goes to Ing. Stanislav Tomášek for consulting the topic, sharing his invaluable experience in the field and patience.

Great thanks also goes to Bc. Jakub Sedlář, Bc. Radoslav Štěpánek for providing and helping with mechanical and theoretical aspects of testing and also to Bc. Ondřej Šereda, Ing. Patrik Bachan, Jakub Dvořák, Daniel Štorc and Martin Edl for providing their electrical, electro-mechanical and software expertise which I elaborate on in this thesis.

My thanks also goes to all past and current members of eForce FEE Prague Formula and our sponsors, without whom this project as well as my thesis would not be possible.

And most importantly, I would like to thank my family, girlfriend and friends for all the support I have gotten during my studies.

Declaration

I hereby declare that the presented Bachelor thesis is my own work and that I have cited all sources of information in accordance with the ethical principles when elaborating an academic final thesis.

.....
Michal Kopiar

In Prague, 31. May 2021

Abstract

Design of electric vehicles revolves around powertrain and gives many possibilities to improve it's dynamic properties. This is especially noticeable in Formula Student competition where the focus on dynamic performance is the main objective.

This thesis discusses selection and configuration of the formula powertrain for this season, searches for creative solutions regarding motors, motor controller and cable harnesses, and elaborates on all the work that goes into working powertrain of an electric vehicle.

Verification of the theoretical concept is also included, discussing the testing phase and resulting in proof of concept of a formula powertrain. Lessons learned and additional potential improvements for next racing season are elaborated on.

Further, I will work on integrating this concept into the formula FSE.10, 10th generation of the eForce FEE Prague Formula vehicle, on-track testing and actual FS competition.

Keywords: electric motor, motor controller, powertrain, IGBT, CAN Bus, vehicle dynamics, PMSM , rotational sensor, resolver, hardware development

Supervisor: Ing. Vít Hlinovský, CSc katedra elektrických pohonů a trakce, Technická 1902/2, Praha 6

Abstrakt

Design elektrických vozidel zahrnuje hnací ústrojí a poskytuje mnoho možností, jak vylepšit dynamické vlastnosti vozidla. To je patrné zejména v soutěži Formula Student, kde hlavním cílem je zaměření na dynamické vlastnosti a výkon.

Tato práce diskutuje o výběru a konfiguraci hnacího ústrojí formule pro tuto sezónu, hledá kreativní řešení týkající se motorů, střídačů napětí a kabelových svazků, a zahrnuje veškerou práci, která se týká fungujícího hnacího ústrojí elektrického vozidla.

Zahrnuto je také ověření teoretického konceptu, diskuse o fázi testování a overuje koncept hnacího ústrojí. Poučení z testování a další potenciální vylepšení pro příští závodní sezónu jsou taky rozpracovány.

Dále budu pracovat na integraci tohoto konceptu do formule FSE.10, 10. generace vozu Formule FEE Prgaue Formula, testování na tratí a finální závedení v soutěži FS.

Klíčová slova: elektrický motor, motor controller, hnací ústrojí, IGBT, CAN sběrnice, dynamika vozidla, PMSM, rotačný senzor, reslver, hardwarový vývoj

Překlad názvu: Konfigurace frekvenčního měniče pro trakční motory elektrické formule

Contents

1 Foreword	1		
1.1 Formula Student Competition ...	1		
1.2 Competition rules.....	2		
1.3 eForce FEE Prague Formula team	3		
2 Introduction	5		
2.1 Formula Powertrain	5		
2.2 Accumulator	5		
2.3 Motor controller	7		
2.3.1 Resolvers	9		
2.4 Electric Motor.....	10		
2.5 Vehicle dynamics	11		
2.6 CAN Bus	11		
3 Powertrain Requirements	13		
3.1 Motor requirements	13		
3.2 Motor controller requirements ..	14		
3.3 Selection	15		
3.3.1 Motor	15		
3.3.2 Motor controller	17		
4 Motor controller configuration	19		
4.1 Communication interface	19		
4.2 Wire harnesses	20		
4.3 Discharge circuit.....	21		
4.4 Cooling.....	22		
4.5 Motor stand and attachment ...	23		
4.6 Configuration	26		
5 Testing	27		
5.1 Setup	27		
		5.2 TGM4 motors.....	28
		5.3 Rear TGN5 TG Drives motors .	30
		6 Conclusions	35
		6.1 Results summary	35
		6.2 Possible improvements for next season.....	35
		6.3 Testing challenges and practical lessons learned during testing	36
		6.4 Table of attachments	37
		A Bibliography	39

Figures

1.1 Percentage of points awarded for individual events [2]	2	5.2 Mobile engineer configuration script	29
2.1 Single motor connection schematic	5	5.3 H-26 laboratory testing setup . .	31
2.2 Render of an accumulator currently being built	7	5.4 TGN5 Torque curve	32
2.3 Silicon Carbide high power MOSFET 6-Pack from Vincotech [8]	8	5.5 3 phase current measuring setup	33
2.4 Schematics of Vincotech 10-PG126PA010MR-L820F88T [8] .	9	6.1 3-phase current measuring setup	38
2.5 RE-15-1-A15 resolver from company ltn-servotechnik	9		
2.6 RE-15-1-A15 resolver internal schematics [10]	10		
2.7 TG drives PMSM on the testing stand, during the testing	11		
3.1 2 stage planetary gearbox with motor	16		
3.2 Preliminary torque curve from motor manufacturer	16		
3.3 Manufactured motor casing	17		
3.4 Lenze DCU 60/60	18		
4.1 Tractive system schematic	21		
4.2 Assembled discharge PCB	22		
4.3 Discharge schematics	23		
4.4 Connection between the shaft and the dynamo	24		
4.5 Coupler	25		
4.6 Gearbox example used for testing	25		
5.1 Lenze DCU 60/60 x-ray	28		

Tables

3.1 Key motor parameters.....	17
3.2 Lenze DCU 60/60 parameters ..	18
4.1 Key TGN5 TG Drives parameters	19
5.1 Measured power input and output values during testing	32
5.2 3 phase power measuring	33



Chapter 1

Foreword

With electrification of transport industry, especially in personal vehicles, need for efficient and powerful electric powertrains arose. This also affects Formula Student teams competing in electric vehicle category are especially sensitive to power, efficiency and reliability of self developed powertrains.



1.1 Formula Student Competition

Formula SAE competition first appeared in 1981 in USA. The main reason was need of US automotive companies to be able to recruit already experienced students from universities. Another reason was the search of these automotive companies for creative solutions for complex problems they had to face. They saw the prospect of a few highly motivated students to be potentially able to find new innovative solutions.

The main point of the competition is to build full size, derivable formula car following the preset rules. The car will then compete in multiple disciplines or events getting points based on the event and result the car achieved. Final score is calculated as a sum of points gained from individual events. [1]

Even though the competition is focused around racing in its nature, the main objective and competition scoring revolves around design and engineering creativity.

Competition first started as combustion vehicles only and quickly spun off into Formula Student Germany in Europe where multitude of teams started. Multiple prestigious races started throughout Europe and world Electric vehicle category was added to accompany combustion vehicles in 2010.

Driverless category was later added in 2017. Whereas you can clearly differentiate between electric vehicle and combustion vehicle categories by type of powertrain (Electric motors or combustion motor), driverless class is

unrestricted in choice of powertrain, it can be powered by combustion motor or electric. It still needs to follow rules for that category.

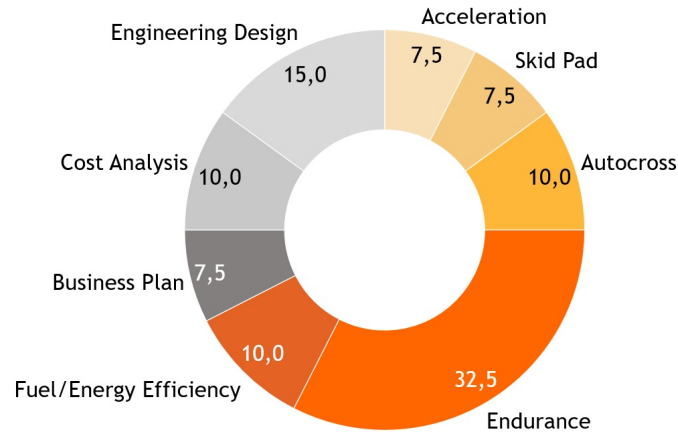

Figure 1.1: Percentage of points awarded for individual events [2]

Points during the race are awarded for dynamic and static events. Dynamic events are actual vehicle performances on-track. In the acceleration event, vehicle is needs to drive 75m from standstill. Scoring then corresponds to the time the vehicle needed to undergo this track. Skid pad event tests the car maximal cornering speed and lateral acceleration of the car. Autocross event measures the time on the 1km track. Endurance discipline is 22 laps around autocross track, measuring around 22km and is by far the most challenging part of the competition and therefore it is rewarded with the most points.

Static events include electrical design report, complex dive into all engineering decisions, simulations and calculations that resulted in the formula that was built. All aspect ranging from chassis, aerodynamics to powertrain and electrical systems are included. These are conducted and evaluated by automotive professionals from many car manufacturers around the world. Other static events are Cost report and Business plan.

1.2 Competition rules

Competition is exceptionally competitive. The main reason Formula Student is so competitive is lack of needlessly restrictive rules. Most of the rules are clearly aimed at maintaining safety. There are little to no rules dictating design or engineering concept as long as it follows safety guidelines.

The main rules restricting electric vehicle powertrain are norms which all wire harnesses and connectors have to follow, precharge and discharge of a tractive system, overcurrent protection, adequate fusing, labeling, temperature monitoring, shutdown circuit and relays.

Significant part of following thesis will rely on these rules as they dictate the main restrictions my concept have to abide by. As rules are yearly updated, this thesis was made following Formula Student Germany 2020/2021 rule book. [3]

1.3 eForce FEE Prague Formula team

eForce FEE Prague Formula as a team started in 2010 as a part of CTU CarTech team. While CarTech team was focused on the combustion competition, eForce, then called CarTech Electric, used resources and knowledge of its combustion counterpart and rebuilt into electric vehicle. In the third competitive season of CarTech Electric, team got re-branded as eForce FEE Prague Formula as it is known now under the banner of Faculty of Electrical Engineering.

Powertrain development has gone through many developmental stages. First vehicle used single BLDC motor with fixed gear ratio, driving just rear wheels with mechanical differential. This was most simple step of converting the combustion vehicle to electric one. Custom built IGBT motor controller controlled the motor.

For vehicles FSE.2 and FSE.3, the team had chosen to run two PMSM without gearbox, because of low RPM range of the motors driving just rear wheels with electrical differential. This came with significant power output increase but added electrical complexity to the system. FSE.4x was the first vehicle with 4 wheel drive driven by 4 fixed geared PMSM and vehicle dynamics unit managing torque vectoring and traction control. For this purpose custom-built dual motor controller with IGBT power switches was developed. Similar setup was used ever since. Front motors were built into wheel hub.

Though the setup was theoretically similar, many improvements were done regarding the weight reduction and vehicle dynamics. After a few years though, this forced reconsideration regarding weight and efficiency of motor-motor controller combination.

Designing new motor controller using SiC technology started around a year ago, but scale of the project forced the team into quick realisation that the project will probably not be sufficiently functional for this season. Buying commercial motor controller for this purpose became the best option.

As for motors, our team got inspired by other Formula Student Electric teams and decided, again for commercially available motors but worked with the company to make custom designed, light weight casing to accommodate one of their rotor-stator options. All of this will be elaborated on further in powertrain requirement section of the thesis.

Chapter 2

Introduction

2.1 Formula Powertrain

Powertrain of an electric vehicle consists of accumulator, power motor controller and electric motor.

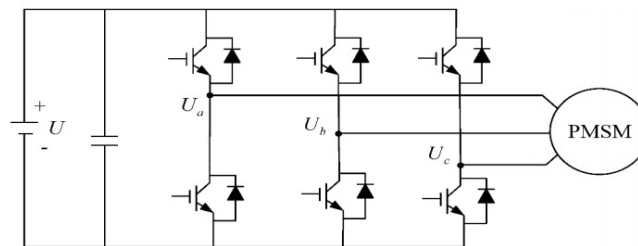

Figure 2.1: Single motor connection schematic

Whereas accumulator functions as energy storage system, motor controller controls the motor and motors convert the electrical energy to the mechanical torque. A brief overview of these functional blocks will follow.

2.2 Accumulator

Accumulator is an energy storage system used to power tractive system as well as low voltage systems of a vehicle. Reversible electrochemical reaction within the cells produces voltage across cell's cathode and anode. Using this voltage difference to produce current or using cells to do work is then discharging the cell, causing it to drop the voltage. This voltage drop can be estimated by battery parameters that include but are not limited to internal battery impedance, nominal and peak voltages, battery capacity.

Similarly, producing negative current with appropriate current source to the cell or using cells to do negative work is charging the cell. Constant current method is one of battery charging methods widely used. This process restores internal cell chemistry to the charged state. Many discharge cycles will hinder maximal cell capacity. Exactly how many cycles there are, will heavily depend on cell type, how the cells will be charged, discharged, frequency of cycles, storage of batteries and capability of surrounding battery management electronic systems.

Limits for peak power drawn as well as maximal voltage are set by competition rules. This is 80kW drawn and 600V peak accumulator voltage. For safe maintenance, battery needs to be divided into segments called stacks. These are connected in series to ensure overall lower voltages and capacities across individual stacks.

Cells used are then connected in series-parallel combination to achieve optimal voltage, while being able to reach peak power being of 80kW on full range of accumulator voltages.

As for the battery pack for this year, we decided to use Melasta - SLPBA942126, LiCoO₂ cells in 144s2p configuration giving us peak voltage 604.8V and 7.4kWh of capacity. Whole battery pack will therefore not be charged to its full voltage to comply with the rules but this small drop will not affect energy stored in accumulator by much.

Complex accumulator management system with cell balancing capability is connected to the battery. This system measures voltages across individual cells, monitors temperatures, includes many safety features like fuses, current measuring hall sensor, high current isolation relays, precharge system with relays and automotive or aerospace connectors with high durability and appropriate ratings. It also includes isolated DC/DC convertor, ensuring galvanic isolation between tractive and onboard low voltage systems and stepping down the voltage of the accumulator to 24V to power all the vehicle's low voltage electronics.

Creation, manufacturing and testing of this accumulator is elaborated on in master's thesis of Petr Hainc, which I am unable to refer to directly, since the thesis is still in progress. References to the previous accumulator designs within the team can be found in Adam Podhrázský's bachelor thesis [4] and masters thesis [5].

Design of the setup can be seen in figure 2.2 where it is possible to see 9 stacks connected in series, each with its own battery management system as well as whole accumulator management system at the top of the picture.

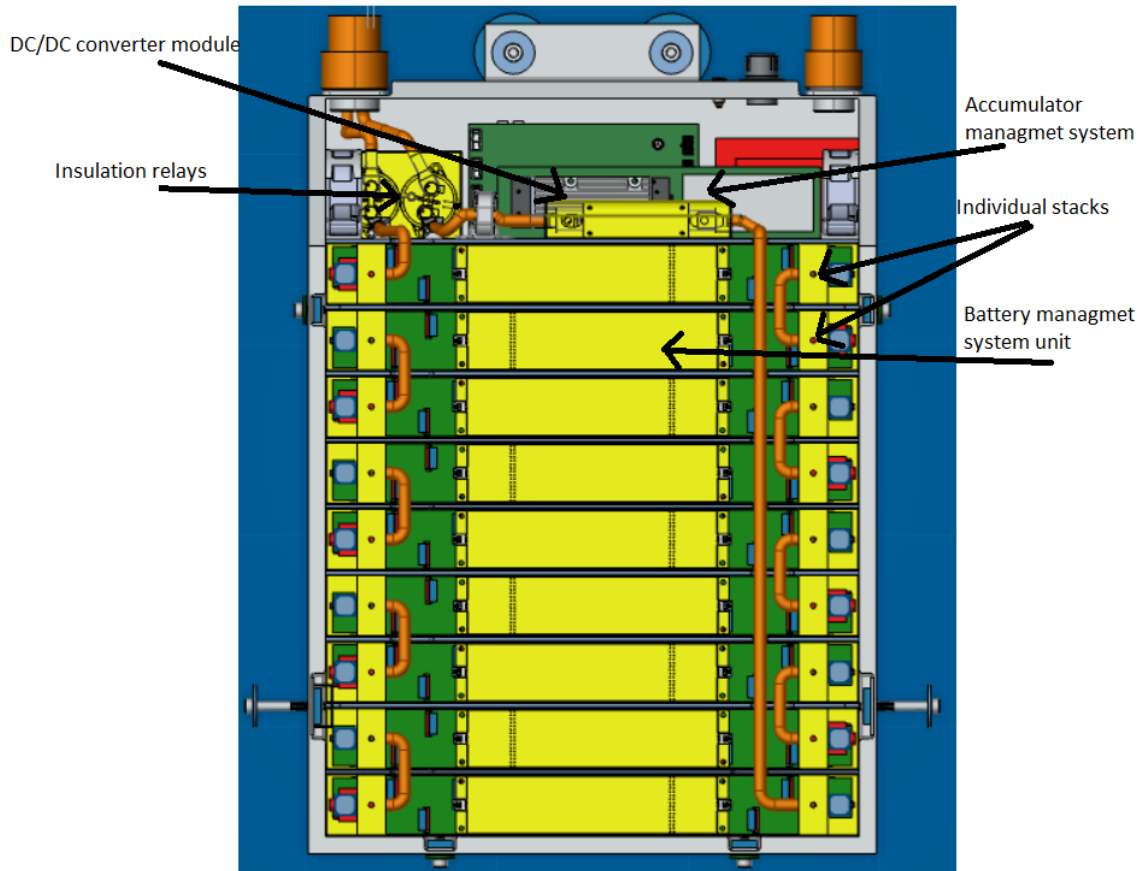

Figure 2.2: Render of an accumulator currently being built

2.3 Motor controller

Motor controller is used to create 3-phase alternating current from accumulator's DC supply. This can be seen as a capacitor and 6 transistors in the figure 2.1. Each single phase is therefore controlled by 2 switches where by switching gates with Pulse Width Modulation a sine wave can produced.

There are a few options for high power semiconductors usable for switching, such as Insulated-Gate Bipolar Transistor(IGBT), Metal Oxide Semiconductor Field Effect Transistor(MOSFET) among others being most common. Input capacitance has to be included to ensure proper function during the systems transient phenoma and to protect the switching silicon from sudden voltage peaks that may occur. This capacitor has to have proper voltage rating for the accumulator, and sufficient capacity.

Exact capacity is hard to determine, because of unknowns within harnesses and parasitic inductance of DC link wires. Therefore it is usually estimated and chosen to be of higher capacitance than estimated, since this does not

cause any electrical downsides. Also low ESR capacitor types are preferred, due to lower parasitic impedance and inductance. For our design though, greater input capacitance means higher weight as well as size and puts higher demands on high voltage DC link discharge circuitry to ensure safety of the whole system. Input capacitance is represented in the TS schematic figure 2.1 [6] There are multiple algorithms that can be implemented into the motor controller in order to drive the motor. Open or closed loop operation are possible. Open loop control can only be used in low-load operations, therefore is not preferred in our use-case.

Closed loop operations are possible with addition of phase current sensing with possibility for sensed or sensorless mode. Sensorless option do require more complex software parametrisation for the exact motor used. Sensed operation is most commonly done by resolvers or encoders in the motor design as well as excitation and evaluation circuitry in the motor controller.

Other angular position sensors do exist, but I will only elaborate more on resolvers, since this is what has been used in eForce vehicles powertrains, I have the most experience using them and they are planned to be included in the current design. Main advantage of resolvers compared to encoder is that resolver is absolute position sensor, while encoder is not.

Information about functionality of motor controllers can be found in Stanislav Tomášek's and Miroslav Ryzek's master's theses [6] [7]



Figure 2.3: Silicon Carbide high power MOSFET 6-Pack from Vincotech [8]

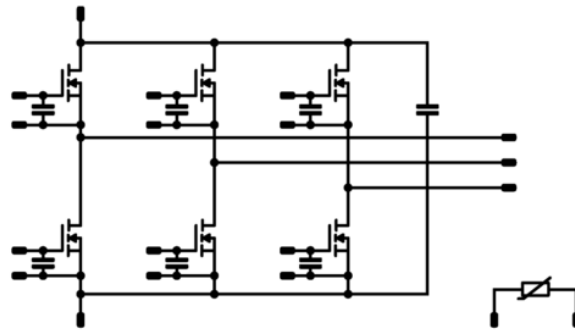

Figure 2.4: Schematics of Vincotech 10-PG126PA010MR-L820F88T [8]

2.3.1 Resolvers

Resolver is transformer, where there is primary and two secondary coils, electrically coupled via rotating core. Excitation signal is sent to the primary coil. This signal is commonly within order of kHz.

Carefully built electrical coupling then results in amplitude change and phase shift of secondary coils. Corresponding sine and cosine of the angle, that the rotational part of the resolver is currently in, being output at the secondary coils. This output signals are of the same frequency as the excitation signal [7]. Example of a resolver can be seen in figure 2.5 as well as its internal schematics in 2.6 [9]

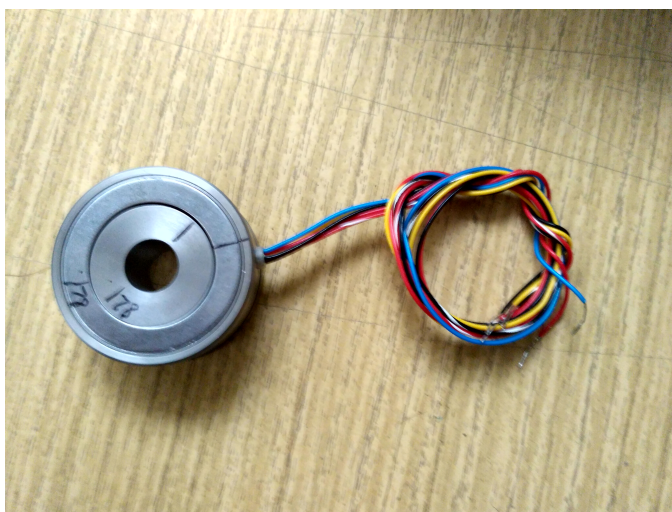
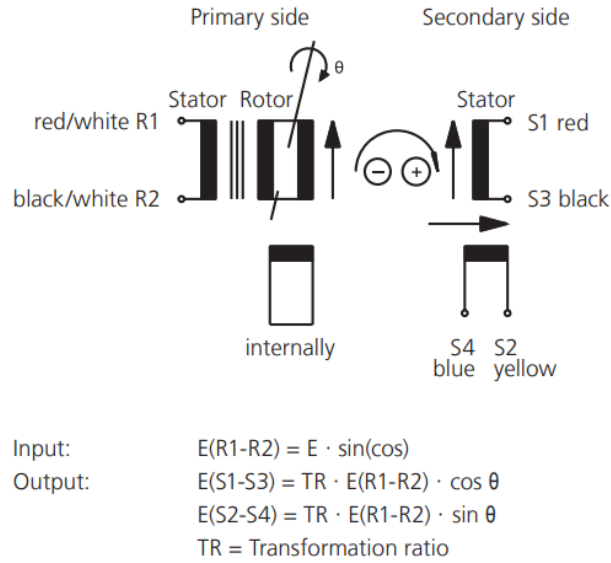

Figure 2.5: RE-15-1-A15 resolver from company ltn-servotechnik



Positive counting direction: Rotor cw as viewed (X→)

Figure 2.6: RE-15-1-A15 resolver internal schematics [10]

2.4 Electric Motor

Electric motor is a type of electrical machine that converts electrical energy to mechanical energy. This is done through magnetic field interaction between wire that current is passing through and other wire or permanent magnets. This interaction between magnetic fields generates torque on the rotor part of the motor. Same process can be reverted in order to create electrical current at motor wires and generate electricity. This process is called regenerative braking. Electric motor consists of rotor and stator. Rotor can be simplified as a rotating part of a motor and stator is therefore static, or not moving part of a motor.

There are many types of electric motors, but further I will talk specifically about permanent magnet synchronous motor or PMSM. Based on the competition rules, weight and efficiency requirements it is considered to be the best choice for our use-case.

PMSM motor consists of permanent magnets in the rotor and windings on the stator. PMSM motors are usually used as servomotors or traction drives. Motor controller is required to drive the motor as well current sensors and angular position sensor provides feedback to the motor controller. This can be achieved in sensed operation via resolvers or encoders or, in sensorless operation as mathematical model of motor in the motor controller to give good estimate of an exact position.

I do consider these drives to be the best choice for the formulas use case, because of their relatively high power to weight ratio, small size. [11]



Figure 2.7: TG drives PMSM on the testing stand, during the testing

2.5 Vehicle dynamics

Vehicle dynamics control unit or VDCU is control unit, responsible for sending torque requests to individual motor controllers and therefore to individual motors. It achieves this by complex software architecture built on simulink models, taking many parameters including but not limited to actual speed based on GPS module and speeds of every motor, accelerometer, gyroscope, steering wheel position, brake and acceleration pedal positions.

After all these variables are evaluated, with frequency of within hundreds of hertz, new torque request are calculated and sent to the individual motor controllers and then motors. VDCU is then responsible to maintain traction control, torque vectoring, active differential, differential braking and recuperation, among others. These commands are sent through communication interface built-in our vehicle. [12]

This extremely brief overview does not explain the complexity of the unit and is elaborated on Marek László's Master's thesis [13]

2.6 CAN Bus

Controller Area Network or CAN is type of bus communication. It is commonly in automotive industry and is also used in our vehicles. CAN is considered to be decentralised network, therefore there is no host computing

unit. Collection of microcontrollers connected to the bus essentially create it. Data is transmitted by so called frames, but only one device at the time. Highest priority message from any device gets the slot to transmit, while other devices wait. The process of determining and sending highest priority frames first is called arbitration. All frames are received by all devices as well as transmitting device.

There are two CAN busses in our vehicle, both connected to each unit. This is to prevent the overload by less significant messages. CAN1 is used for high priority messages essential for driving like car state, torque requirements or brake pedal position. For powertrain, this is the more important bus.

Chapter 3

Powertrain Requirements

3.1 Motor requirements

As we are planning to upgrade from our previous vehicle, we decided that we are going to use 4 identical motors placed in each wheel hub. Since this is going to be unsprung mass, we need those motors to be relatively small and light in order to fit inside the wheel hub. Next we want motors to sum up to at least 80kW of power.

This is to comply with the competition rules. That would mean at least 20kW of maximal motor power, though we want a bit more. Based on our previous experience and simulations, ideal maximal power for a motor will be more around 30kW. To comply with the rules we will never use all 4 motors at full power, but from a vehicle dynamics point, at full power we want more power to be at the rear of the car, therefore rear motors need to be able to handle additional power requirement. For the front motors, the main use of additional power stems from need to regenerate energy while braking. There we are looking to regenerate as much power as possible during braking, decreasing the battery size and weight. There during the recuperation phase, most of the power going through the system back to the battery, will go through front wheels.

As for the torque requirements, we expect to have large torque, but also going to design planetary gearbox with fixed gear. This point shifts our focus towards finding correct motor from looking for exact torque range to RPM range. This is because torque, RPM and power are related in following formula.

$$P = \tau \cdot \omega \quad (3.1)$$

where P is power [W], τ is torque [Nm] and ω is angular velocity [$\frac{rad}{s}$]. For simplicity of calculations I will further convert angular velocity to revolutions

per minute, where $1 \frac{rad}{s} = 9.549RPM$. Further, all angular velocity references will be in RPM (revolutions per minute) units, unless specified otherwise.

Considering the system after the gearing, we want maximal RPM to be around 1400. This number comes from maximal desired vehicle speed, around $130 \frac{km}{h}$ and size of tire used.

We also want to be able to control motor at low vehicle speeds for slow transits and high torque at lower RPM range to achieve fast accelerations. This means that ideally we want to find motor with wide RPM range and then have relatively high gearing ratio.

Next, individual motors should be as efficient as possible. We can compare efficiency map of motor with our on-track testing data to determine how much power we will be losing in our average track RPM and/or torque requirements. Next, even in optimistic scenario of 95% motor efficiency, we are looking at 1.5kW losses on rear motor during 30kW input. So adequate cooling solution needs to be part of the motor casing.

3.2 Motor controller requirements

For this season, we decided to buy one of the industrial motor controllers. This is mainly due to the fact that development of our own motor controllers solution takes a lot of time and we already started the process. Yet it will not be finished for upcoming season, so during this gap year, industrial solution seems to be the way to proceed.

Another reason for the new motor controller was long awaited decision to build 600V tractive system from 400V. This is planned to decrease current in all powertrain parts, achieving higher efficiency as well as decreased weight of conductors and wire harnesses.

Our primary concern when choosing the motor controller is compatibility with motors we choose. Therefore maximal power and angular speed at which it will be able to drive the motor at are crucial. This can be calculated from datasheet specifications of maximal motor controllers output frequency by following formula.

$$\omega = \frac{2\pi \cdot f}{n} \quad (3.2)$$

Where ω is angular velocity of a motor [s^{-1}], f is motor controllers output frequency [Hz] and n is number of pole-pairs of a motor.

Every motor needs to be able to hit its peak power and angular speed with some redundancy. Motor controller must also be able to work with full range

of input voltages that may occur in tractive system, while the battery is fully charged, close to discharged or under heavy load. Same logic also applies for current rating. Full power, during any input voltage that may occur, must not result in more current than the motor controllers rating. In our case that means 600V of maximal tractive system voltage, dropping down to estimated 430V when being close to be discharged and under heavy load. For example 30kW motor would necessitate at least 70A motor controllers current rating under lowest accumulator voltage.

Another important factor from electrical point of view is the variety of algorithms it uses for control. For configuring the powertrain, it will be useful to be able to use sensed control, with resolvers or encoders. But for in car use, unless direct advantages will be shown in sensed control during testing, sensorless options will save us weight on wiring and will be advantageous.

Size and weight also play a big role in choosing the motor controller. This one of the most restraining requirements, since options that would be electrically viable are plentiful. With above mentioned power ratings, single channel motor controllers are the most abundant. Four motors need to be controlled, therefore four conventional motor controllers are an option. There are some dual options, that are built to control two motors simultaneously. Those are usually heavier and larger, but smaller than two single channel controllers. Going for dual channel controllers also reduces amount of power cables for DC link input as well as saves on water cooling lines. Adequate cooling options were built-in most industrial controllers that we were choosing from, and although necessary, did not play a significant role in making final choice.

There were few less important requirements that we considered in our search. Communication method with the motor controller could be fixed with some intermediate custom-made unit, but we prefer solutions with built-in CAN bus interface that we could just plug into. Also, rules of Formula Student competition demand that on request or in any fault state, tractive system of the vehicle must be discharged to under 60V under 5 seconds. But this problem is also solvable by custom PCB that would help built-in discharge in motor controller to meet the goal of 5 seconds.

■ 3.3 Selection

■ 3.3.1 Motor

For motors, we decided to use *Fischer Elektromotorenmodel* : *TI085–052–070–04B7S–07S04BE2*. This is combination of rotor and stator, for which we would need to design and make a custom built case with cooling and space for resolver.

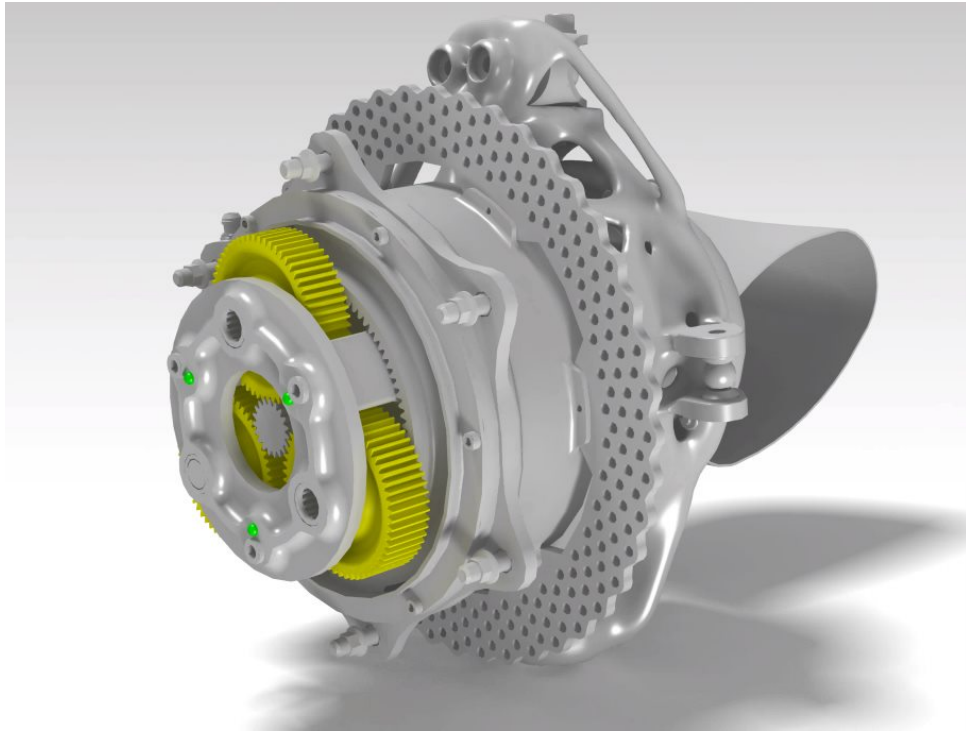

Figure 3.1: 2 stage planetary gearbox with motor

For resolver we decided to use *TLNRE – 15 – 1 – A15*. This option allowed us to make casing without many redundancies and mounting points in precise locations we need. With this, we will build a two-stage planetary gearbox with total gearing ratio of 13.3:1, converting 29.1Nm peak motor torque to 387.03Nm per motor or 1548.12Nm combined for 4 wheels. This gearbox can be seen in figure 3.1. Additional motor parameters can be seen in figure 3.1 and graph 3.2. This graph shows torque curve under different conditions.

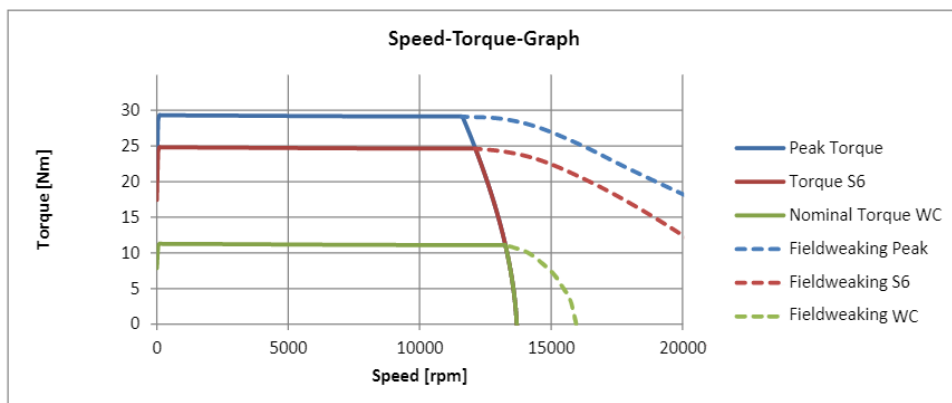

Figure 3.2: Preliminary torque curve from motor manufacturer

Table 3.1: Key motor parameters

Number of polepairs	4
Nominal Torque [Nm]	11.1
Nominal Current [A]	22.6
Nominal Speed [RPM]	13250
Nominal Power [kW]	15.4
Peak Torque [Nm]	29.1
Peak Current [A]	61
Speed at peak Torque [RPM]	11600
Peak Power [kW]	35.4

**Figure 3.3:** Manufactured motor casing

■ 3.3.2 Motor controller

As for motor controller, we decided to go for two, *LenzeSchmidhauserDCU60/60* units. The main advantage of these is the fact that they are dual channel, providing the ability to control two motors at the same time, drastically reducing size requirements and giving us ability to make whole formula much smaller; with 60kW of peak power per channel and wide range of input voltages ranging from 200V to 800V controled via public and/or private CAN interface.

There is in-built discharge circuitry in the motor controller, but it is inadequate to comply with the competition rules [3]. Therefore, custom discharge circuit will be necessary. Other motor controller parameters can be found in table 3.2

Table 3.2: Lenze DCU 60/60 parameters

Peak power per channel [kW]	60
DC-link voltage [V]	200-800
Maximal DC current [A]	104
Nominal Current [A]	58
Switching frequencies [kHz]	4,8,16
Control method	Sensored or sensorless
Max. modulation frequency [Hz]	599

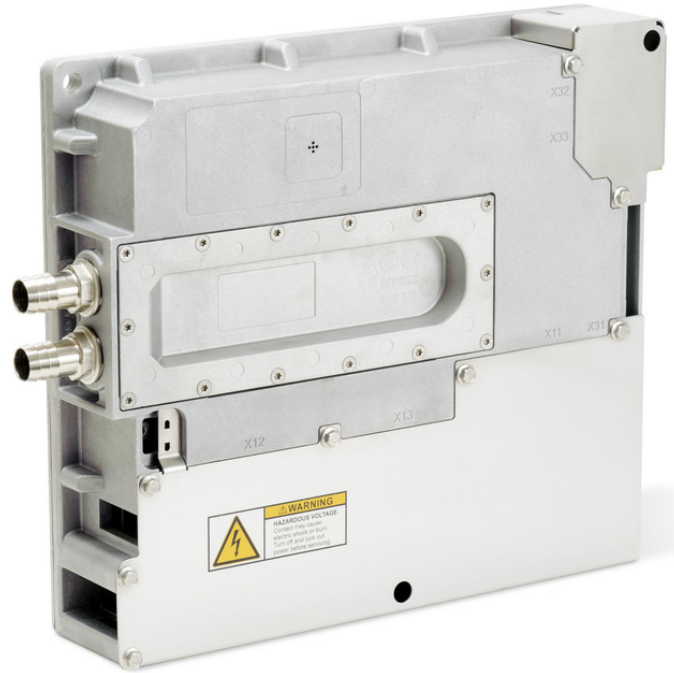
**Figure 3.4:** Lenze DCU 60/60

Maximal modulation frequency of 599Hz is datasheet value for the motor controller. This frequency is insufficient for driving the motor above $940 \text{ rad} \cdot \text{s}^{-1}$ or 8985RPM as per equation 3.1 which is significantly below the motor's angular speed datasheet value. Also according to the datasheet, this value is adjustable and has no effective upper limit. This has been confirmed by the manufacturer. Testing of this hypothesis will be one of my primary concerns.

Chapter 4

Motor controller configuration

Due to the fact that the chosen motor from *FischerElektromotoren* was still in a process of being delivered, We decided to start testing the *LenzeSchmidhauserDCU60/60* with our previous motors from Czech company *TGDrives*. Parameters of *TGN5TGDrives* motors can be found in 4.1

Table 4.1: Key TGN5 TG Drives parameters

Number of polepairs	5
Nominal Torque [Nm]	11.0
Nominal Current [A]	38.2
Nominal Speed [RPM]	3000
Peak Torque [Nm]	47
Peak Current [A]	171
Peak Power [kW]	36

Specifications of this motor are as following: PMSM, 36W peak power, 10 000 RPM peak angular velocity, 5 pole pairs with one pole pair resolver *TLNRE – 15 – 1 – A15*.

4.1 Communication interface

LenzeSchmidhauser has its own computer interface called Mobile Engineer, where upon establishing the communication I was able to configure the motor controller parameters.

Establishing the communication was done via *VECTOR1610CAN* interface. External termination of CAN busses was required with 120Ω resistor. Since the motor controller is made to be able to be controlled on one bus with multiple other *Lenze* motor controllers, different CAN ID needs to be properly assigned to each motor controller unit. This is done through

proper interlock connection within the communication connector on the motor controller. This needs to be calculated through the formula in the Software documentation provided by the manufacturer Lenze.

Motor controller needs power of 24V. Through one of the mobile engineer python scripts we can then set the CAN ID. Correct public, and private bus baud rate needs to be inputted as well as driver for the VECTOR 1610 CAN interface. Through Mobile Engineer software, parametrisation could now start.

4.2 Wire harnesses

Complete powertrain schematics can be seen in figure 4.1. All harnesses were professionally made and shielded. The connectors used were made by *Amphenol* and are all automotive, aerospace or military standard. All conductors and connectors have adequate voltage and current rating.

Wire harnesses used for testing are simplified version of the 4.1 schematics. It is simplified to only two high current cable harnesses. The first is shielded, twisted double link for DC power to the motor controller, with connector as a counterpart to the motor controller insert on the motor controller side. On the other side it consists of 2 crimping lugs.

The second harness connects three phase of the motor controller to the tested motors. Since these testing connectors and wire harnesses are not feasible to be made equivalently to our vehicle due to price, some simplifications were made. The long three phase harness again goes into three crimping eyes that can be bolted to any motor connection without the need of replacing the wires. Three phase wire harness to the motor is also shielded and shielding was connected to the motor casing at the end. For testing purposes this approach had one more advantage i.e. the ability to measure phase voltages.

Other, low power wires were also needed to be made for testing. These consists of motor controller CAN and power wires with adequate interlocks to ensure safety and sensed resolver connection from motor to the motor controller. Within this signal harness, motor temperature sensor was also included.

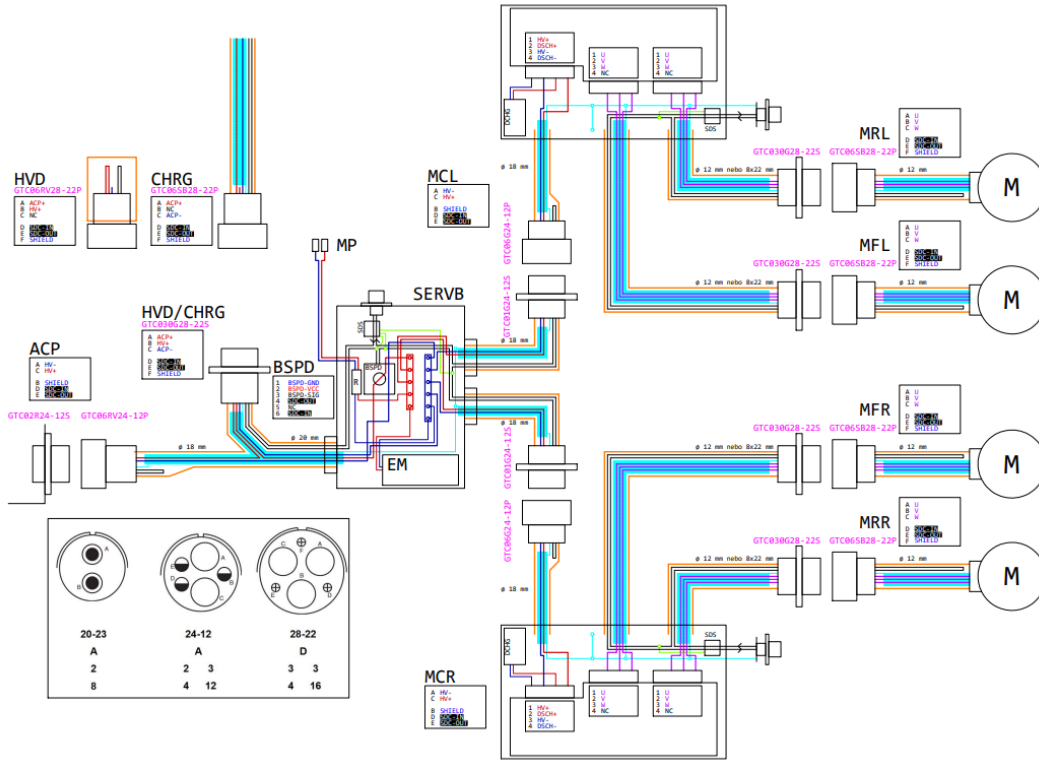

Figure 4.1: Tractive system schematic

4.3 Discharge circuit

As already mentioned, built-in discharge of the motor controller is inadequate. There will be two motor controllers on the DC link with $240\mu F$ of DC capacitance each. Each motor controller will therefore have one dedicated discharge circuit. This circuit is placed within the motor controller enclosure.

In order to comply with the competition rule limit of full discharge within 5 seconds, following assumptions were made. Worst case scenario is represented by fully charged capacitors with the maximal tractive voltage of 600V. Safe voltage is considered to be 60V as per competition rules.

$$V_{new} > V_{max} \cdot e^{-\frac{t}{R \cdot C}} \quad (4.1)$$

Where V_{new} is the value that we discharged to and therefore 60V, V_{max} is the maximal accumulator voltage of 600V, t is time in seconds and is 5s and R and C represent discharge resistors [Ω] and capacitor capacity $C = 240\mu F$ respectively. Solving for R gives us maximal resistance in order to comply with the competition rules.

$$R < \frac{-t}{\ln\left(\frac{V_{new}}{V_{max}}\right) \cdot C} = \frac{-5}{\ln\left(\frac{60}{600}\right) \cdot 0.00024} = 9048\Omega \quad (4.2)$$

$$P_{min} = \frac{U^2}{R} = \frac{600^2}{9048} = 39.8W \quad (4.3)$$

Suitable resistors of $7.5k\Omega$ were chosen with 2 resistors in series and 2 in parallel for total resistance to be still $7.5k\Omega$ but getting desired discharge effect as per 4.1 but splitting the power dissipation equally between 4 resistors. With this setup, total power dissipation will be $48W$ and high voltage system will be discharged in 4.14s. [14]

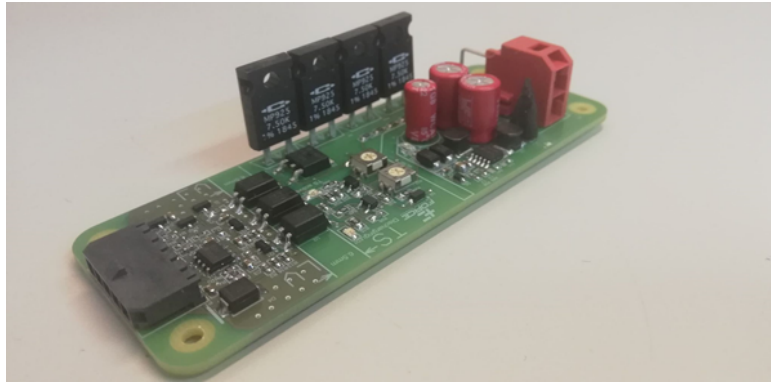

Figure 4.2: Assembled discharge PCB

Other factors consider during the design, like galvanic isolation of HV and LV parts of the board, discharge disable signal to stop discharging since discharge will be turned on by default. Signals from HV side represents discharge on/off/fault state as well as tractive system voltage $>60V/<60V/fault$. These signals are mandatory according the competition rules and are directly connected to the Tractive System Active Light (TSAL). Finished unit can be seen in figure 4.2 and schematic in 4.3.

PDF of schematics will be included in attachments. Most of the credit for discharge circuit goes mainly to Jakub Dvořák whose input and time made this unit.

4.4 Cooling

Both motor and motor controller can be cooling water cooled. In the vehicle, there are two water circuits, one dedicated to the right side and one to the left side. They include catch cans, cooled motors and motor controllers and go back to the radiator. Radiator is positioned on the side of the car and gives us some natural cooling capability. In case that the car is stationary or

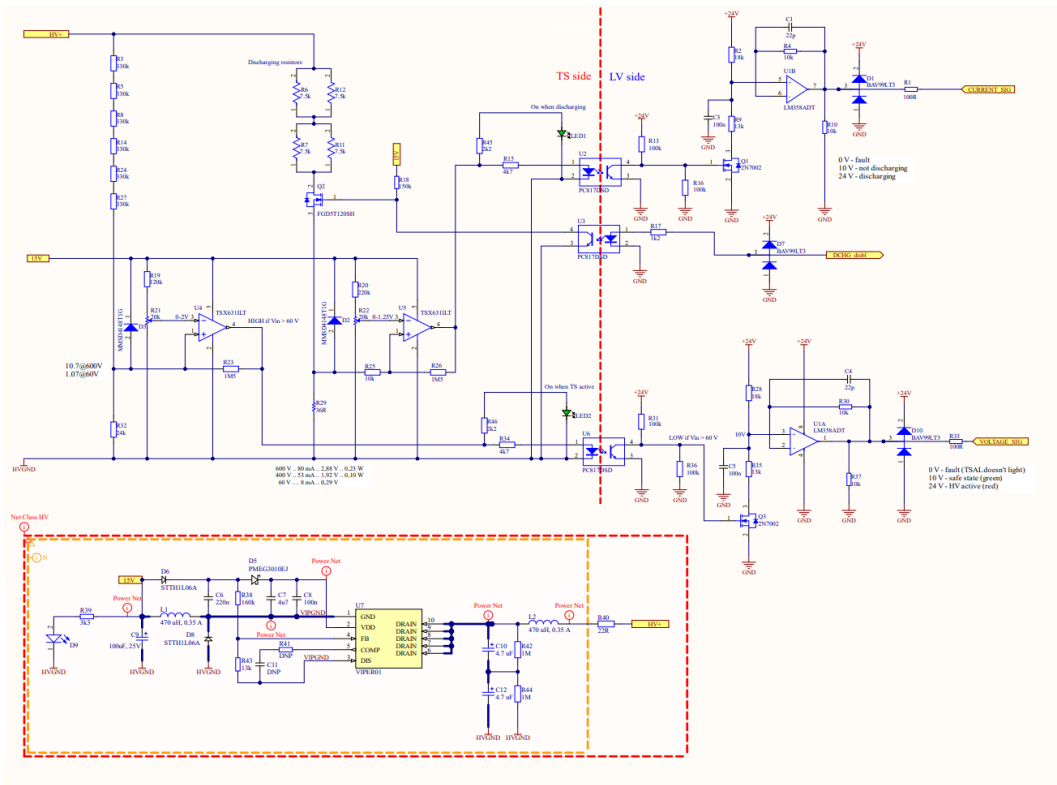

Figure 4.3: Discharge schematics

water circuits heat up more than we would want, there are also fans forcing air through the radiator.

Three cooling testing setups were used. During low-power testing, water cooling was disconnected and only temperatures were monitored. During power testing in CTU FEE H-26 laboratory, reservoir of water with submerged water pump was set up with the water circuit going through motor controller and motor in series. Last setup used was custom cooling setup present in laboratory VTP Roztoky under supervision of doc. Ing. Pavel Mindl, CSc. There is controllable water cooling system with heat exchange in the laboratory. With setup present in the laboratory, we managed to keep water temperature at $6^{\circ}C$.

4.5 Motor stand and attachment

Universal testing stand can be seen in figure 2.7, consisting of steel beams welded together. Large steel plate with an opening in the middle for the motor, is welded to the front side of the construction. Motor is bolted from one side via regular motor attachment with positive locking nuts. Only motor shaft then goes through the large opening on the steel plate of the stand. On the

other side of the steel plate, gearbox is bolted and sealed using silicon to the motor and stand. Gearbox is filled with oil and has an output of cardan joint where universal shaft connects it to the dynamo.

This setup was used in all of the following testing scenarios, with end of the shaft being connected to coupler. The coupler was different and made to achieve good connection with any dynamo that it was connected to. Connection between the shaft and dynamo, coupler and planetary gearbox can be seen in figures 4.5, 4.4, 4.6. Stand was securely connected to the table with bolts.

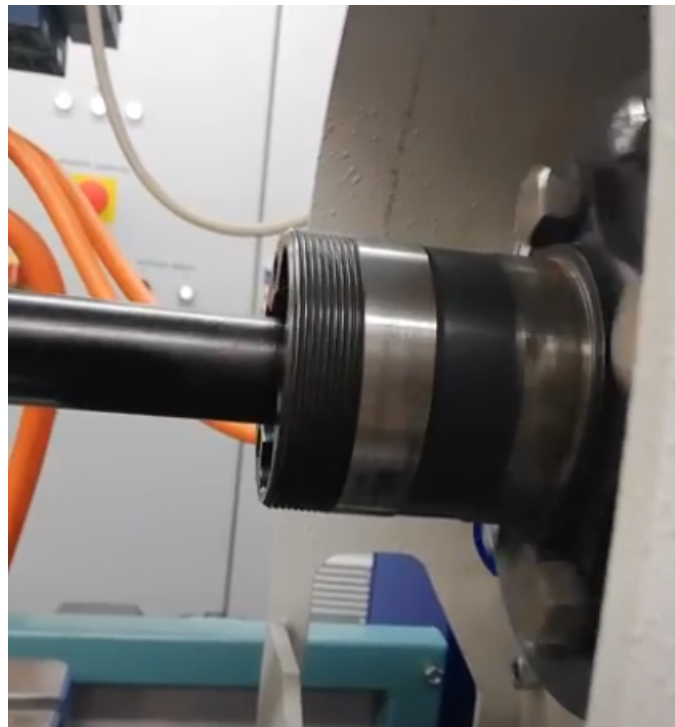

Figure 4.4: Connection between the shaft and the dynamo

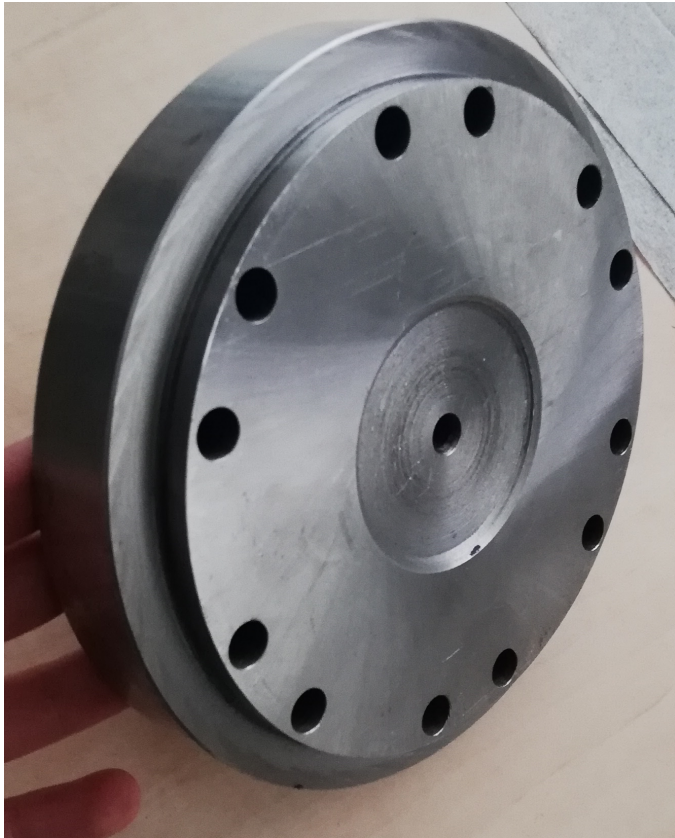

Figure 4.5: Coupler

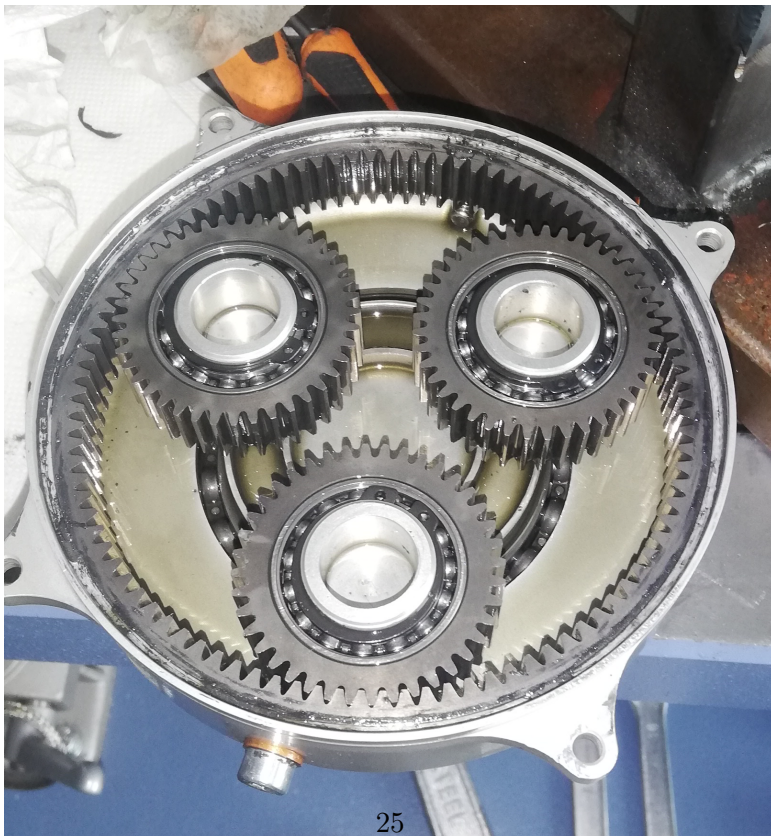

Figure 4.6: Gearbox example used for testing

4.6 Configuration

Mobile Engineer software uses Python 2.7 scripts. There are multiple scripts included with the software and their source code can be adjusted if needed. As for commissioning, following scripts are necessary: VCS/SLVCS (Vector Control Synchronous/Sensor-less Vector Control Synchronous), Resolver settings, Feedback settings, and Speed Controller settings.

Although for our use case, We are going to be controlling motor with torque requests, in *MobileEngineer* software Speed Controller script is used to define some parameters. These do limit torque control and have to be set-up. These include maximal torque built-up meaning maximal change in torque per second, RPM build-up and motor orientation.

With vector synchronous control with resolvers, most of the parameters like nominal torque or nominal current can be gotten from Motor datasheet. Other parameters like stator resistance or Ld/Lq inductance can be measured through the motor controller. This was enough to spin the motor for first time under no-load. Some other parameters were not easily accessible and will be measured and tested further.

There are a few more configuration that there were no scripts for but were required for our use case. These include communication timeout, CAN baudrate and motor speed messages for traction control. These were set-up by exact CAN message format as found in datasheet as well as inputting user override code as a message right afterwards. This code cannot be found in datasheet, and was obtained from manufacturer.

For example, the procedure to change the baud rate of the Public CAN to 500kBd is as following:

- Set APPC Public CAN baudrate from “5” to “6” (APPC Object 4020h/01h)
- Save this setting to internal flash by entering “1234” to Store Parameter Store (APPC Object 4001h/01h)
- Upload store command until “1234” is in again (APPC Object 4001h/01h)
→ store was successful
- Reset KL15 (restart device)

These do refer to the motor controller’s datasheet which can be found in the attachments.

Exact configuration for motors and results are included in following chapter.

Chapter 5

Testing

5.1 Setup

Three motors were planned to be subjected to configuration and testing. FSE.09 front and rear motors as well as new Fischer motors were planned. Actual testing was eventually done only on FSE.09 motors. Reason for this is prolong delivery times by manufacturer. Tested motors are modified versions of *TGN5* and *TGM4* motors from *TGDrives* company.

Since tested motor will be from previous vehicle, 400V is the target voltage. Three different power sources were used for the testing, the first one being laboratory power supply available in our workshop. This power supply is limited by 3kW at 500V. The second one is 400V accumulator from our previous vehicle which can provide full 80kW if need be, but needs to be recharged periodically. Last power source we used was built-in battery simulator in *VTPRoztoky*. Battery simulator is programmable to specifications beyond specifications of our accumulator.

With the testing, x-ray of enclosed motor controller was done to better understand its internal components and its possible workings. This can be seen in figure 5.1. A few markings have been added into the x-ray to better elaborate on the internal workings of motor controller.

1. Film Capacitors on input DC link $240\mu F$
2. Two power IGBT modules with visible water cooling heat-sink right above.
3. Hall sensors for two phase currents per module. Third is therefore calculated in microcontroller.
4. Three phase motor controller output connectors

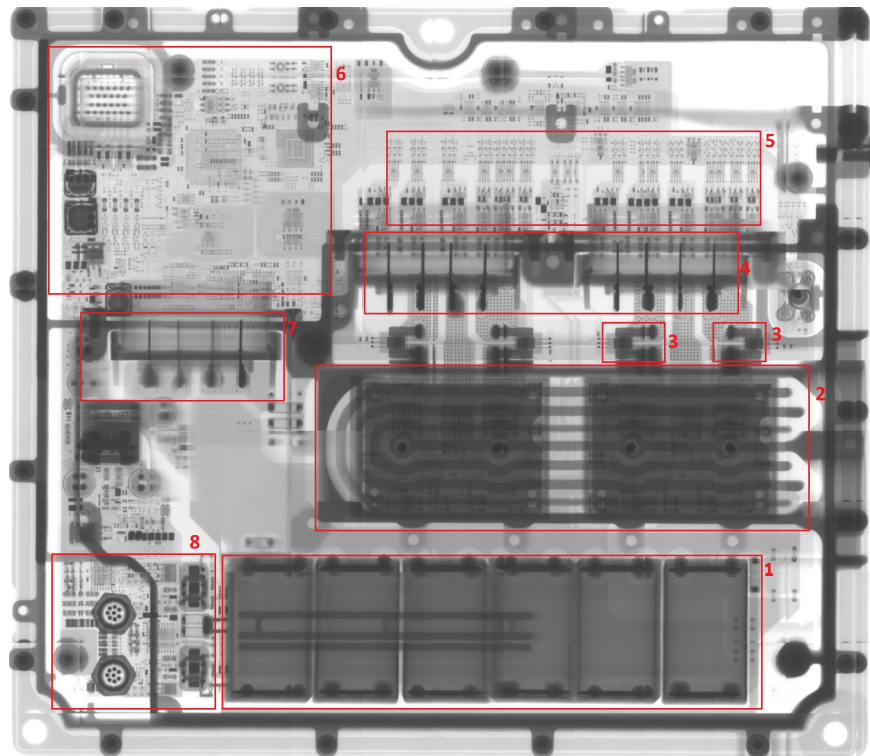

Figure 5.1: Lenze DCU 60/60 x-ray

- 5. Insulated gate drivers for IGBT module
- 6. Control and processing logic
- 7. Input high voltage DC link connector
- 8. Input for angular position sensor.

5.2 TGM4 motors

This motor was used in eForce's previous vehicles as front motor. This was thanks to its small size and weight, with pilots preferring to have more power at the rear wheels. Therefore there was no need for more powerful front motors.

The goals of this motor the testing were following:

- Familiarise myself with the configuration environment.
- Spin the motor without load.
- Observe the system's behavior on the full RPM range.

- Explain and fix any unexpected behavior.

Observing the full RPM range was necessary to test, whether the motor controller can reach output frequencies above its datasheet maximum of 599Hz since the motor has 5 polepairs and maximal angular velocity of up to 10000 RPM therefore should be driven at maximal speed with frequency of 833Hz as per equation 3.2. 3kW power supply in our workshop was sufficient for this testing and was only one used.

Reference datasheet for this motor can be found in the attachments. This motor was not tested under load, since the stand does not accommodate it, and it is not planned to be used in the following season. It served as a low powered 9.7kW proof of concept for motor controller parametrisation. Most of the parameters were copied from motor datasheet to individual configuration windows.

MOBILE Commissioning: Resolver Settings Private CAN

Version: 6.1.0
Revision: 322119

3/4

MOBILE

Configure Resolver

pole pairs of the motor: 5

pole pairs of the resolver:

resolver position offset: rad

invert resolver direction:

[Hide Adv. Settings](#)

calibrate amplitude:

calibrate phase and offset:

dynamic offset factor:

Method 4 (Pole Position Identification) ▾

Configure Method 1 (Externally Tuned Motor)

mech. frequency you'll rotate the motor: Hz

Configure Method 2 (Standstill Alignment)

align current: A

Figure 5.2: Mobile engineer configuration script

Some parameters were constantly changed during the testing and system

behavior was monitored. Safety measures of the motor controller many times prevented us, from adjusting some values outside of reasonable boundaries.

These mainly include resolver settings, which affects pole position and phase sequence. There are multiple methods for pole position identification and they worked to various degree. Problem was that the motor phase order was not marked and it led more to trial and error testing scenario. It is also important to clearly define positive direction of rotation, so that resolver signal will not be interpreted as negative of actual rotation.

Best option we found for the resolver offset alignment is externally turning the motor. For the automatic alignment settings, precise speed of external rotation has to be known. This was sometimes hard to achieve so Mobile Engineer graphing script was used for this, that if used correctly, did not require precise spinning of the motor. Hand turning motor and graphing *dutyU* *dutyV* and *MotorFeedbackPosition* was sufficient. Correct number of detected polepairs can be checked in the graph as *dutyU* and *dutyV* frequency should be polepair-times greater than *MotorFeedbackPosition*, regardless of resolver offset.

Sequence the motor phases can be checked as the maximum of the *dutyU* should be in advance compared to the maximum of the *dutyV*. Exact resolver offset can be then checked by rising zero-crossing of the *MotorFeedbackPosition* should be at the position of the falling zero-crossing of the *dutyU*. If not, manual adjustment has proven to be the most efficient.

After some trial and error, we managed to reach full speed range. Unexpected behavior consisted of motor violently shaking without spinning, wrong direction of spinning and supposedly invisible RPM limit of 3000. Analysing the data pointed to the cause of shaking to be opposite orientation of resolver to the motor spin. This was confirmed by motor working after revisiting steps above. Wrong direction spinning was fixed then by again changing the direction of both resolver and motor, and repeating the calibration of the resolver offset. RPM limit was caused by improper setting of one of the limiting parameters and changing it solved the problem.

Motor and motor controller temperatures were slightly above room temperature without the water cooling attached. Motor ran smoothly and I consider all my goals for this part of testing to be achieved.

■ 5.3 Rear TGN5 TG Drives motors

Even though *TGN5* motors will not be used in new FSE.10 electric vehicle, they will be used in new Driverless vehicle with Lenze DCU60/60 motor controller for driving rear wheels. Testing of these motors was divided into multiple phases: no-load testing, similar to TGM4 motor testing. Limited

load testing was carried out in H-26 CTU FEE laboratory, *VTPRoztoky* under load testing and in-vehicle testing.

First stage of no-load testing went exactly as TGM4 motor testing. Familiarity with the testing apparatus was a significant help. Testing in H-26 laboratory was limited due to the long term malfunction in the available dynamo. Dynamo was then used as flywheel, achieving 6kW in peak power, before requiring to before reaching speed limit. Proof of concept for recuperation or recharging battery from motor was tested here as well.

For recuperation testing, 3kW laboratory power supply was insufficient to provide enough power, and broken the connection when inverse current was applied. With last year's accumulator, testing was successful and negative torque applied to the fast spinning flywheel resulted in negative current through accumulator. This setup was cooled with reservoir and water pump method.

Some problems arose with used transmission used that can be seen in figure 4.6. No major visible defects were observed, but during testing it commonly went 20°C above the water cooled motor, even though it is directly bolted to the motor. During testing, noticeable mechanical sound came from the transmission but when spun manually, it provided little to no resistance as it should. New motor with new transmission should solve this problem, but unusually high temperatures kept occurring throughout testing.

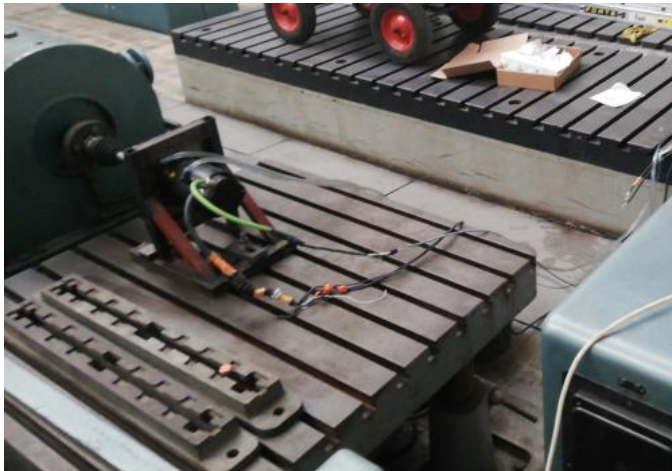

Figure 5.3: H-26 laboratory testing setup

VTPRoztoky testing followed. The main objective here was to test the motor controller under the load. Malfunctioning transmission was still a concern, but temperatures were regularly checked for overheating. Following torque curve was measured as a result of first testing.

X-axis represents angular velocity of the dynamo in RPM. Motor angular velocity is 6.75 times higher, due to transmission's gear ratio. This testing was done with dynamo being velocity-controlled. Torque requests were then

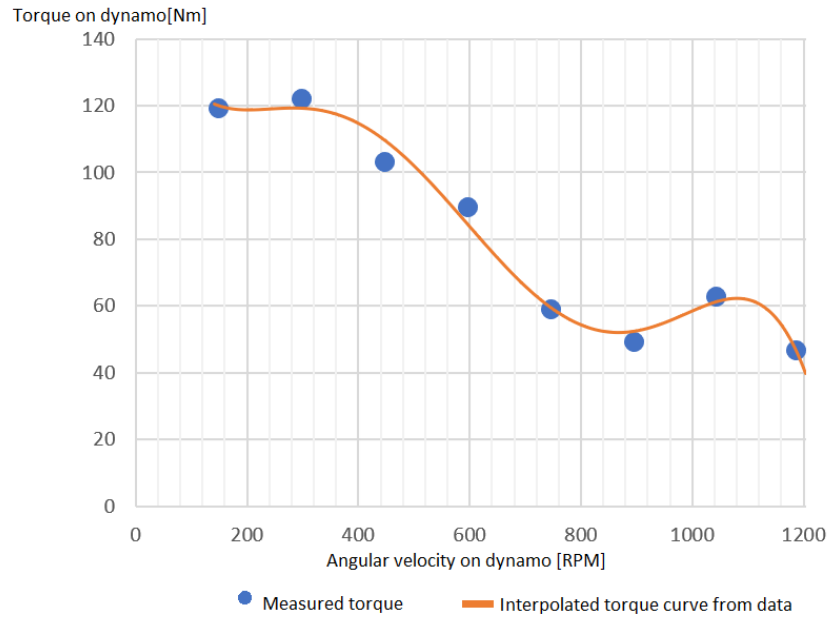

Figure 5.4: TGN5 Torque curve

Table 5.1: Measured power input and output values during testing

n [RPM]	τ [Nm]	P_dynamo [W]	P_inverter [W]
5036	11.3	883	1991
8010	46.0	5707	10965

sent to the motor controller. Highest torque achieved is marked on the graph. When torque was set beyond the marked value, motor controller's overcurrent protection was triggered. This was due to not insignificant losses in the system under this load and motor controller's overcurrent protection could not reach full motor power with 400V nominal voltage.

Reason for this unusual torque curve is still undetermined, but is suspected to be motor design flaw in combination of the malfunctioning gearbox. This can be again supported by following table, that measured power going to the motor controller and power delivered to the dynamo. Just few values are shown, because of large amount of data collected. 5.1

With n being angular velocity of motor in RPM and τ measured torque at dynamo. These occurrences with noticeable extremely low efficiency were common especially in higher RPM range. This observation might be caused by the same problem that caused high RPM rage torque curve deformation. Cooled by 6°C water, motor controller kept cool, peaking around 11°C . Motor temperatures were peaking at $45-50^{\circ}\text{C}$ same as gearbox. The gearbox heated up significantly faster than the motor and then the motor slowly warmed up to the gearbox temperature during the testing. These observations are suspected to be caused by the same problem.

Table 5.2: 3 phase power measuring

n [RPM]	τ [Nm]	P_inverter [W]	P_3-phase [W]	P_dynamo [W]
4029	84.4	8250	7269	4228
8011	46.8	8242	7707	4454

For this reason, we decided to also measure 3 phase power between motor controller and motor. This was done via built-in system in laboratory, connecting 3 phases to their lab equipment and passing 3 phase wires through lab hall sensors all connected to internal logging device as can be seen in table 5.5

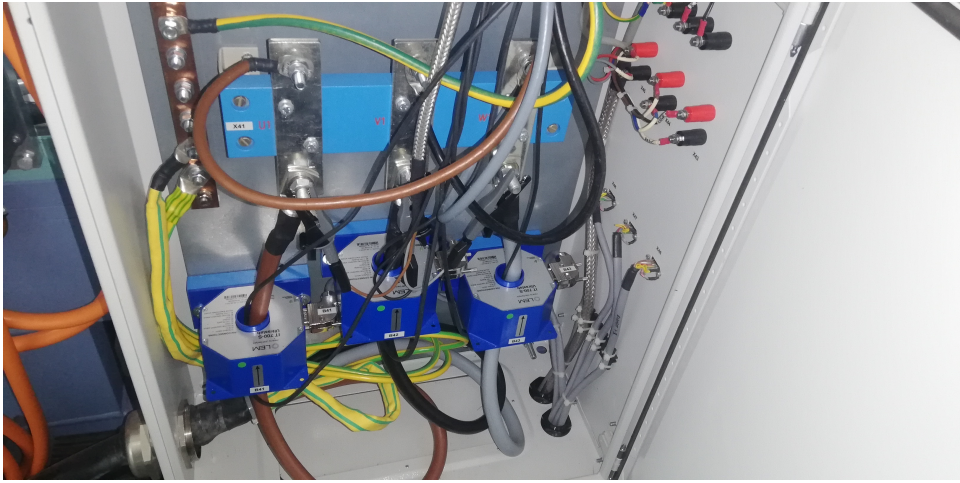
**Figure 5.5:** 3 phase current measuring setup

This method has proven to be unreliable, most probably due to 3 phases having to be unshielded and untwisted for measuring, therefore causing EMI with other nearby electronics. After data analysis, inconsistencies within the most of the data samples was noticed. Sample of constant data is provided in table 5.2.

With n being again angular velocity of motor in RPM and τ is measured torque at dynamo. This samples of data was deemed partially trustworthy. This is because within data, some samples correctly resembled angular velocity of dynamo or input voltage that the EM field had no effect on. These few samples could have been accurate, since no inconsistencies were found in data analysis.

This even further confirmed our suspicion of faulty gearbox with significant losses especially on the higher end of the RPM range.

With this knowledge, one of the motor controllers was put into Driverless vehicle and underwent on-track testing. Same type of motor and gearbox were used, but not the potentially faulty ones. First on-track testing was limited to just rear motors with 10kW power limit set in. This went smoothly

and behaved as expected. During second on-track testing, limit was raised to 20kW per motor and regenerative braking was also tested. Single overcurrent occurrence was caused probably by faulty settings, and did not occur after recalibration.

Chapter 6

Conclusions

6.1 Results summary

Above described testing took part between January of 2020 and May of 2021. Logistics and difficulties of making this possible will be further described in section 6.3 Testing challenges and practical lessons learned during testing.

As per 21.5.2021, deadline for this thesis, these motors are supposed to be delivered in following week. They will be subjected to the same and probably more extensive testing as other motors. Since my bachelor's thesis is aimed for motor controller configuration and testing this will hopefully not be huge issue, and through experience gained, testing with them will go more smoothly.

Chosen motor controller performed as expected. Testing validated proof of concept of using Lenze DCU 60/60 as viable option for upcoming racing season. On-track testing confirmed these results. New motors do have similar parameters to the tested motors and are expected to behave similarly. Most, if not all problems described are suspected or were confirmed to be the results of faulty equipment rather than the motor controller or human error. This was mainly confirmed during on-track testing.

Further testing in laboratory or on-track will take place in upcoming weeks. New motor will be similarly configured and tested. Then it will be subjected to on-track testing with new FSE.10 vehicle.

6.2 Possible improvements for next season

More, on-track testing will be required to sufficiently determine drawbacks and therefore possible improvements.

One of possible improvements is weight and size of the Lenze motor controller. It can be seen in figure 5.1, amount of aluminum put into the motor controller casing, redundancy in input capacity as well as IGBT modules being overall heavier. As I have already mentioned, self-built 4-channel motor controller using silicon carbide MOSFETs is already being developed and we expect, to subject it to similar testing within the next racing season. Size and weight of this new motor controller should be smaller.

New 600V accumulator has not yet been tested on-track. In previous years, our use of regenerative braking was heavily restricted by temperature build-up in the accumulator. New accumulator was built around this problem and is expected to perform better than the previous one. This still needs to be tested. Further improvements though should let us use more energy from recuperation and therefore decrease size and weight of the future accumulators we use.

Reliability of wire harnesses and their proper manufacturing has been long term issue within our previous vehicles. We hope to improve on that, sparing no expense on the most professional connectors and tools. Human error plays big part in these issues so new, electro-mechanical group was created, consisting of multiple eForce members. We hope this will increase quality and reliability of harnesses. If this will not be enough, professional harness manufacturing company will be tasked to make the harnesses. As connectors and wires already take not insignificant part of the team's budget, additional sponsors will have to be found to cover this cost in future.

Improvements to self developed motor casing have already been designed. These include slight reduction in weight and additional small case on the back of the motor. This case will include terminal block for 3 phase and interlock. One of the possible solutions is reducing weight of the wires. Motor controller could be directly connected to motor only with terminal block serving as a connection on the side of the motor, losing the need for heavy *Amphenol* bayonet connector.

6.3 Testing challenges and practical lessons learned during testing

Many parts of testing and setup were barely mentioned, but in reality took weeks even months to set up or fix. Setting up all the necessary apparatus to perform few measurements in *VTPRoztoky* laboratory took around two months. Following paragraph will include some challenges and lessons learned.

Importance of periodical laboratory reports was confirmed, even though they were short and were only shared with small group of people working on FSE.10 vehicle. These short reports have proven to be invaluable throughout the process writing of this thesis. They provided accurate timelines and errors

that occurred as well as fixes. Only ones more important to the thesis topic were mentioned, but having some text to remember the testing from 6 months ago was crucial.

Coupler to the dynamo was briefly mentioned but took serious effort to manufacture. Round steel piece had to be found, cut, and put on lathe until it resembled what we needed. This task alone took 2 weeks and help of multiple experienced students from Faculty of Mechanical Engineering.

Also, not checking equipment when getting ready for testing can be detrimental. One week of testing was delayed because of motor controllers cooling circuit cover. This cover was screwed in, but missed insulating rubber gasket. Reason, why this cover was screwed in without gasket, which was left in tool box is still unknown. Missing rubber gasket was invisible from outside, and was only noticed after significant leaks and water spillage in *VTPRoztoky* laboratory. Another instance of not checking equipment was when insufficient insulation at the 3-phase wire, the side that it is crimped to the connector cause high voltage sparks to the ground. Motor controller was not damaged and no one was hurt, but this trivial mistake gave us significant scare.

Issues like one in the picture 6.1 can often cause days of aimless debugging. Properly crimping and trying to pull each wire one after another became the most useful practice, on its own probably saving multiple days.

6.4 Table of attachments

1. Dischage schematis.pdf
2. Fischer motor datasheet.pdf
3. Lenze motor controller hardware manual.pdf
4. Lenze motro controller reference manual.pdf
5. Peliminary efficiency map of Fischer motors.pdf
6. TG drives TGM4 datasheet.pdf
7. TG drives TGN5 datasheet.pdf
8. Input for angular position sensor.pdf
9. Wire harnesses schematics for FSE10.pdf

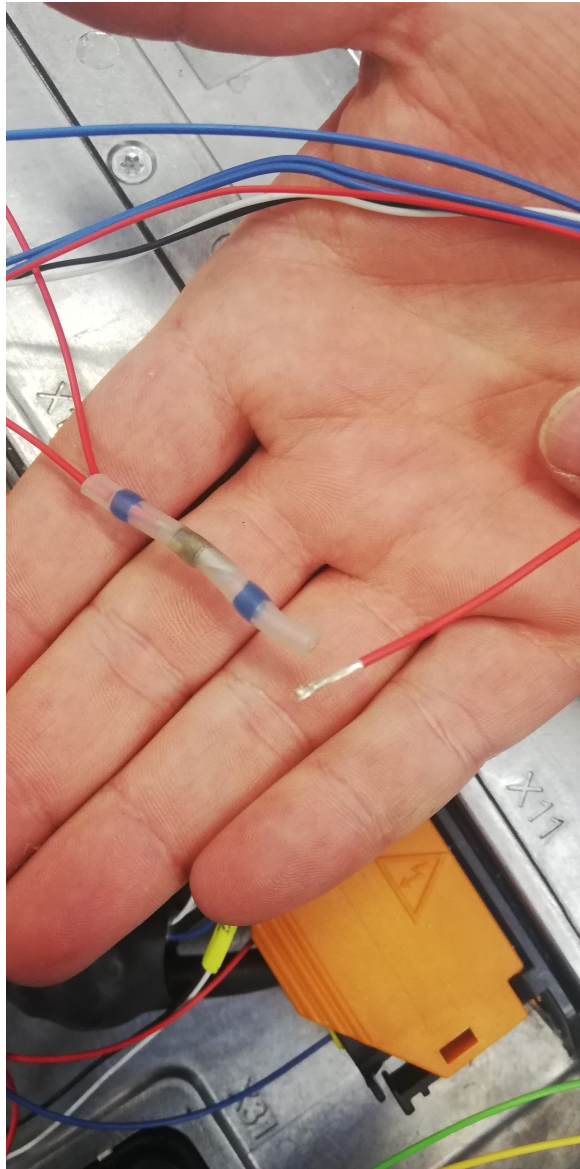

Figure 6.1: 3-phase current measuring setup

Appendix A

Bibliography

1. *Formula SAE* [online] [visited on 2020-05-21]. Available from: https://en.wikipedia.org/wiki/Formula_SAE.
2. *Formula Student competition* [online] [visited on 2021-05-20]. Available from: <https://eforce.cvut.cz/en/formula-student/>.
3. *Formula student germany Rules* [online]. Formula Student Germany [visited on 2021-05-20]. Available from: https://www.formulastudent.de/fileadmin/user_upload/all/2021/rules/FS-Rules_2020_V1.0.pdf.
4. PODHRÁZSKÝ, Adam. *Akumulátorová baterie pro elektrickou formuli. Bakalářská práce*. České vysoké učení v Praze: Fakulta elektrotechnická, 2016.
5. PODHRÁZSKÝ, Adam. *Electrochemická impedanční spektroskopie elektrochemických zdrojů. Diplomová práce*. České vysoké učení v Praze: Fakulta elektrotechnická, 2019.
6. RÝZEK, Miroslav. *Řízení pohonu elektrického vozidla Formula Student*. České vysoké učení v Praze: Fakulta elektrotechnická, 2015.
7. TOMÁŠEK, Stanislav. *Design of an electric powertrain for the Formula Student-class vehicle* Diplomová práce. České vysoké učení v Praze: Fakulta elektrotechnická, 2019.
8. *10-PG126PA010MR-L820F88T module* [online]. Vincotech GmbH [visited on 2021-05-10]. Available from: <https://www.vincotech.com/products/product-details/10-PG126PA010MR-L820F88T.html>.
9. LEONHARD, Werner. *Control of Electrical Drives*. Springer-Verlag Berlin Heidelberg, 2001. ISBN 978-3-642-56649-3.
10. *RE-15-1-A15 datasheet* [online]. LTN SERVOTECHNIK GMBH [visited on 2021-05-10]. Available from: https://www.ltn-servotechnik.com/fileadmin/imported/products/RE_15_EN_01.pdf.

11. HRABOVCOVÁ, Juha Pyrhönen Lappeenranta; Tapani Jokinen; Valéria. *Design of Rotating Electrical Machines, 2nd Edition*. Wiley, 2013. ISBN 978-1118581575.
12. NG, Liuping Wang; Shan Chai; Dae Yoo; Lu Gan; Ki. *PID and Predictive Control of Electrical Drives and Power Converters using MATLAB / Simulink*. Wiley, 2015. ISBN 9781118339442.
13. LÁSZLO, Marek. *Flight Control Solutions Applied for Improving Vehicle Dynamics. Diplomová práce*. České vysoké učení v Praze: Fakulta elektrotechnická, 2019.
14. VOBECKÝ, Jan a Vít ZÁHLAVA. *Elektronika*. Praha: GRADA, 2005. ISBN 978-80-247-1241-3.