



SE M VĚSTĚNĚ	
□	0,004
▨	0,003
□	A

ZÁŠKRBAT

OŠETŘENÍ  
 VĚSTĚNĚ  
 PŘI 300 000 100  
 19. 11. 2009  
 Z. M.

4:1 MT 200  
 KONTROLNÍ SNÍMAČ

440-732-3

Single flank composite measurement, Worm gears						
		OTT 2978 HR GEARTEC2				
Worm	snek	Wormgear	kolo	Measured points	1000	
Number of teeth	$z$	1 / R	Number of teeth	$z$	72	
Axial module	$m_x$	2.120	Pitch diameter	$d_m$	152.496 mm	
Pressure angle	$\alpha_n$	15.0000°	Shaft angle	$W$	0.0000°	
Pitch diameter	$d_m$	47.764 mm	Worm position	$M'_y$	14.000 mm	
Centre distance	$a'$	100.000 mm	Worm position	$M'_z$	69.000 mm	
Measuring speed	50rpm	Load torque	2.00 Nm		Note	Diplom thesis
Part No.		Contract No.		Machine No.		
Date		06/08/2020 08:04		Checked by		
Petra Zdanska				Note		
Diplom thesis						

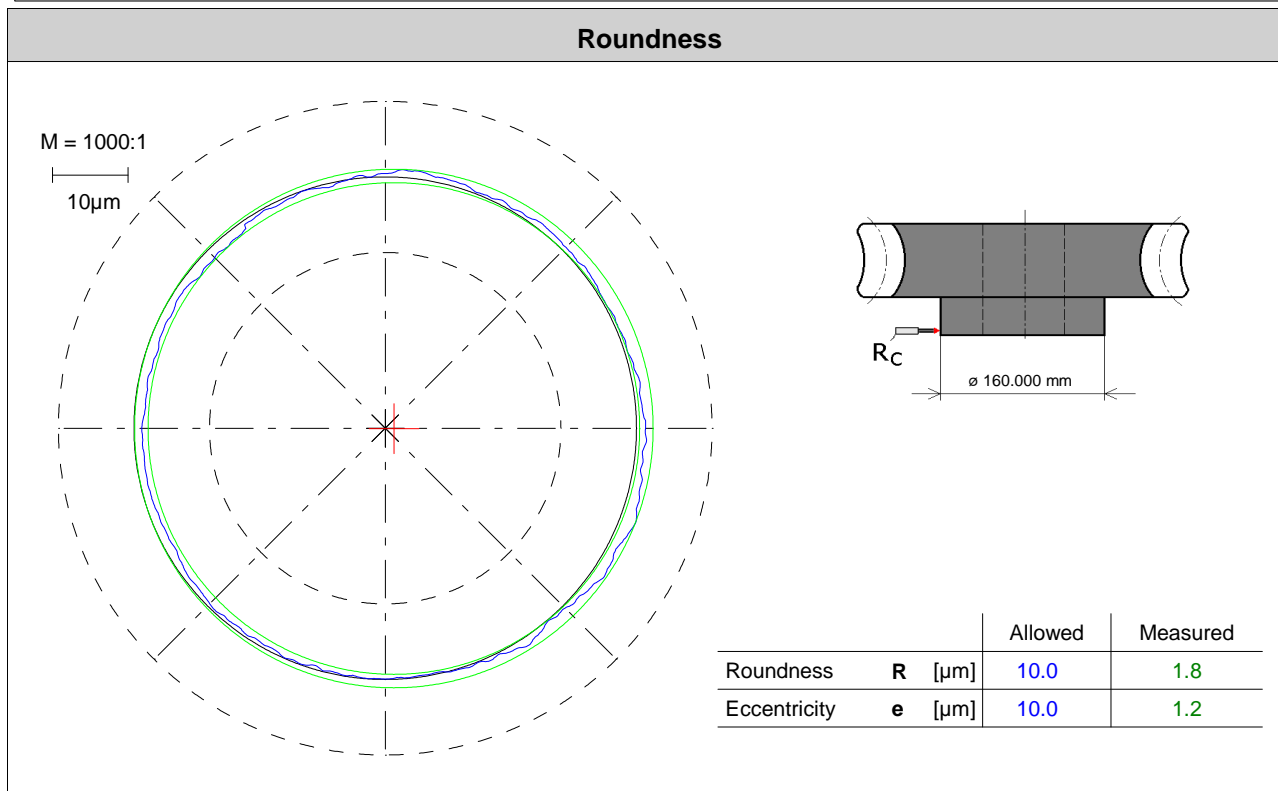

### Single flank composite measurement, Worm gears



OTT 2978 HR GEARTEC2



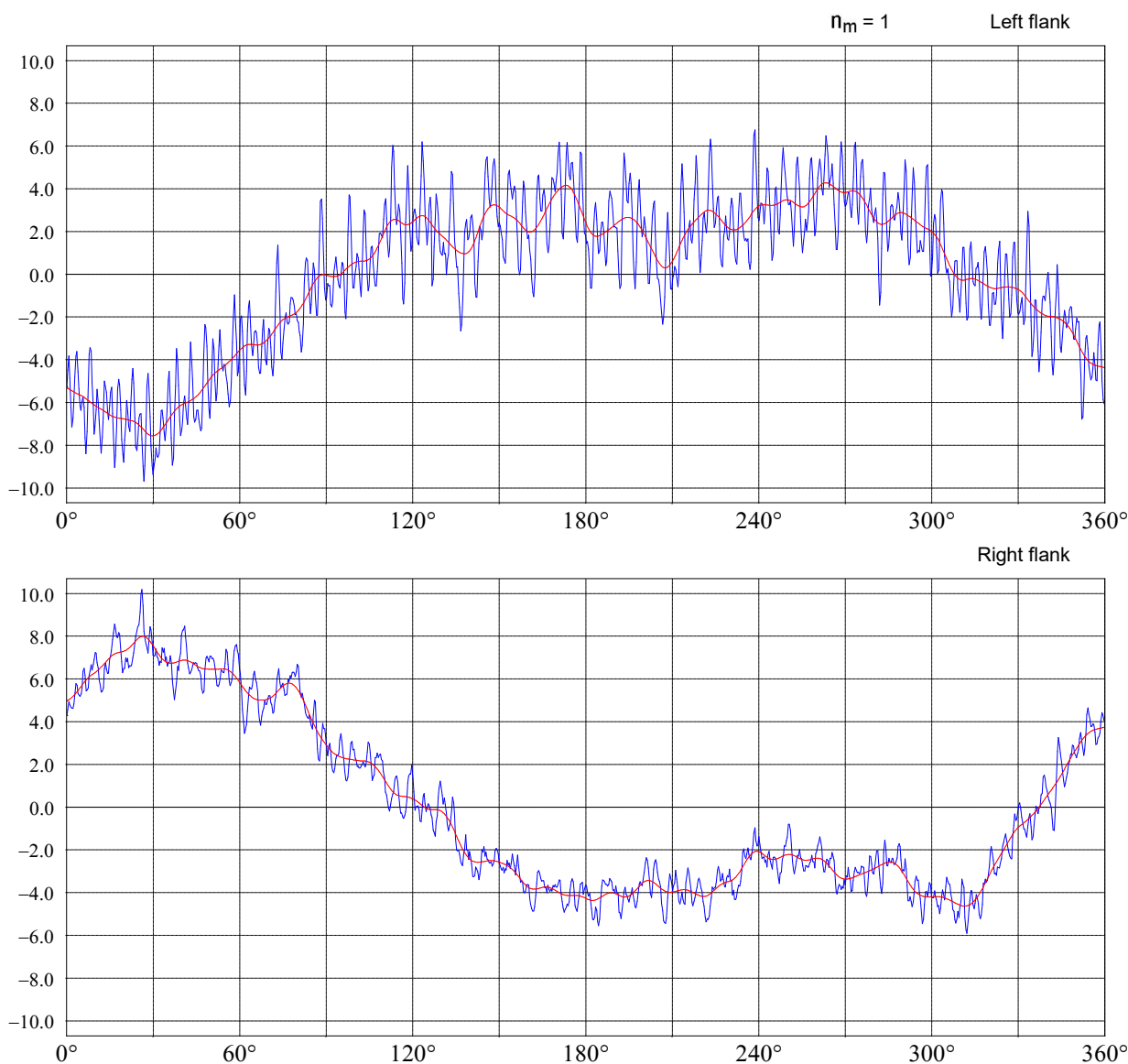

Worm	snek	Wormgear	kolo	Measured points	1000
Number of teeth	$z$	1 / R	Number of teeth	$z$	72
Number of teeth	$z$	1 / R	Number of teeth	$z$	72
Axial module	$m_x$	2.120	Pitch diameter	$d_m$	152.496 mm
Pressure angle	$\alpha_n$	15.0000°	Shaft angle	$W$	0.0000°
Pitch diameter	$d_m$	47.764 mm	Worm position	$M'_y$	14.000 mm
Centre distance	$a'$	100.000 mm	Worm position	$M'_z$	69.000 mm
Measuring speed	50rpm	Load torque	2.00 Nm	Note	Diplom thesis
				Date	06.08.2020 08:04
				Checked by	Petra Zdanska

$F_i', f_i', ["]$



Standard: DIN 3974	F-factor 25%	Allowed	Measured
Total composite deviation	$F'_i$ ["]	30.0   2	16.2   1    14.9   1
Single flank composite dev.	$f'_i$ ["]	13.4   2	6.5   1    3.2   1
Average value	$f'_{i,m}$ ["]		4.6   1    1.9   1
Mean value	$f'_{i,max}$ ["]		7.6   1    4.3   1
Long wave component	$f'_l$ ["]		11.9    12.7
Short wave component	$f'_k$ ["]		5.4    2.4
Backlash - tangential	$\bar{j}$ [mm]	0.020 + 0.150	0.115

Single flank composite measurement, Worm gears						
		OTT 2978 HR GEARTEC2				
Worm	snek	Wormgear	kolo	Measured points	1000	
Number of teeth	$z$	1 / R	Number of teeth	$z$	72	
Axial module	$m_x$	2.120	Pitch diameter	$d_m$	152.496 mm	
Pressure angle	$\alpha_n$	15.0000°	Shaft angle	$W$	0.0000°	
Pitch diameter	$d_m$	47.764 mm	Worm position	$M'_y$	14.000 mm	
Centre distance	$a'$	100.000 mm	Worm position	$M'_z$	69.000 mm	
Measuring speed	50rpm	Load torque	2.00 Nm		Note	Diplom thesis
Date	06/08/2020 08:44					
Checked by	Petra Zdanska					

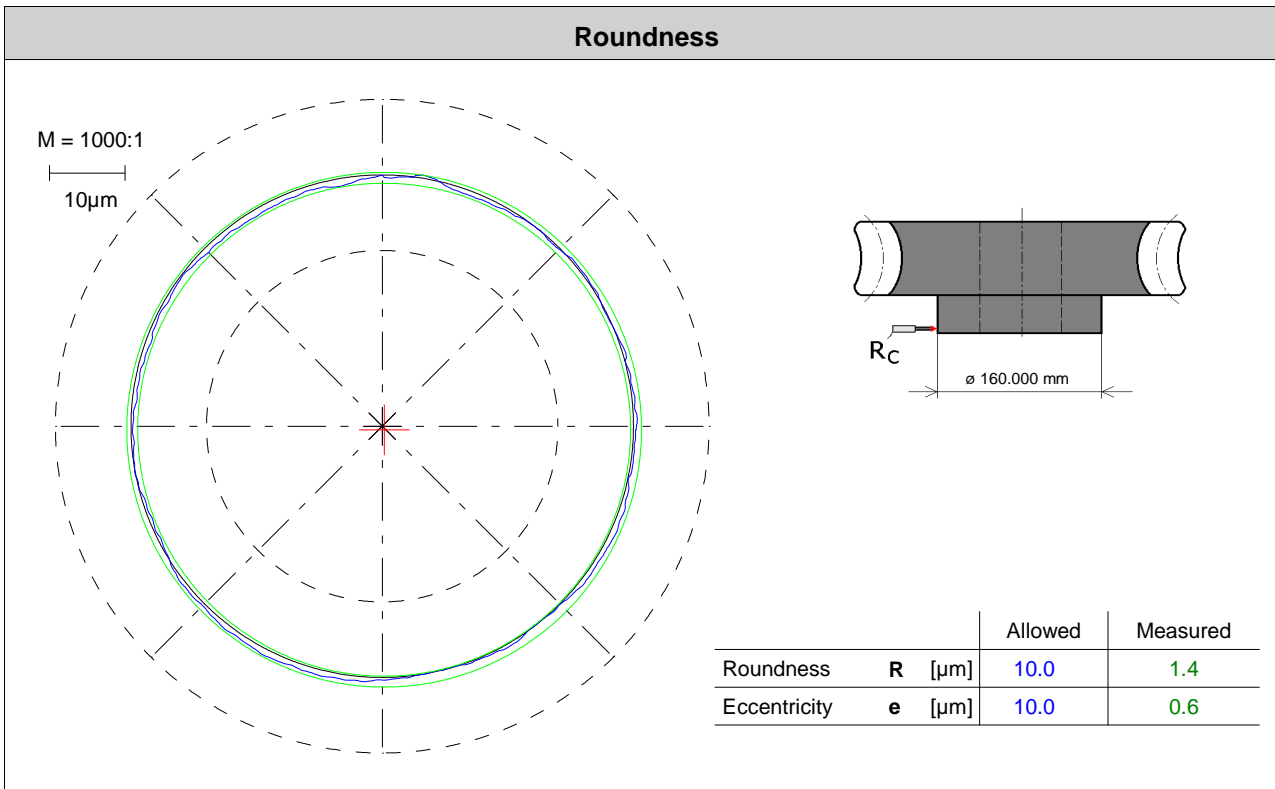

### Single flank composite measurement, Worm gears



OTT 2978 HR GEARTEC2



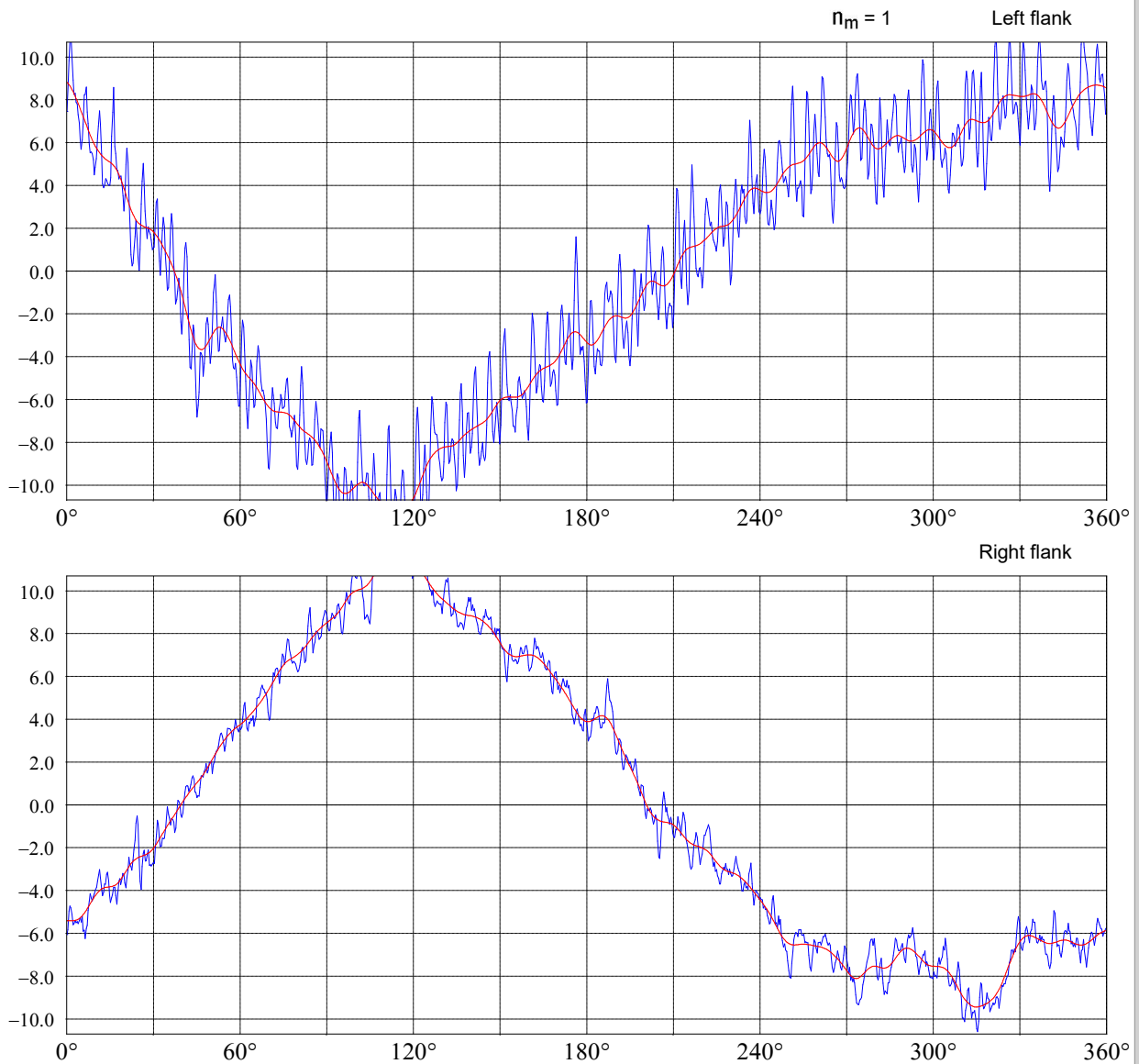

Worm	snek	Wormgear	kolo	Measured points	1000
Number of teeth	$z$	1 / R	Number of teeth	$z$	72
Number of teeth	$z$	1 / R	Number of teeth	$z$	72
Part No.					
Contract No.					
Machine No.					
Date					06.08.2020 08:44
Checked by					Petra Zdanska
Note					Diplom thesis

$F_i', f_i', ["]$



Standard: DIN 3974	F-factor 25%	Allowed	Measured
Total composite deviation	$F_i'$ ["]	30.0   2	24.9   2    23.5   2
Single flank composite dev.	$f_i'$ ["]	13.4   2	7.3   1    3.2   1
Average value	$f_{i,m}'$ ["]		4.6   1    1.9   1
Mean value	$f_{i,max}'$ ["]		8.1   1    4.1   1
Long wave component	$f_l'$ ["]		19.7    21.4
Short wave component	$f_k'$ ["]		5.7    2.2
Backlash - tangential	$\bar{j}$ [mm]	0.020 + 0.150	0.117

Single flank composite measurement, Worm gears						
		OTT 2978 HR GEARTEC2				
Worm	snek	Wormgear	kolo	Measured points	1000	
Number of teeth	$z$	1 / R	Number of teeth	$z$	72	
Axial module	$m_x$	2.120	Pitch diameter	$d_m$	152.496 mm	
Pressure angle	$\alpha_n$	15.0000°	Shaft angle	$W$	0.0000°	
Pitch diameter	$d_m$	47.764 mm	Worm position	$M'_y$	14.000 mm	
Centre distance	$a'$	100.000 mm	Worm position	$M'_z$	69.000 mm	
Measuring speed	50rpm	Load torque	2.00 Nm		Note	Diplom thesis
Part No.		Contract No.		Machine No.		
Date		06/08/2020 10:47		Checked by Petra Zdanska		

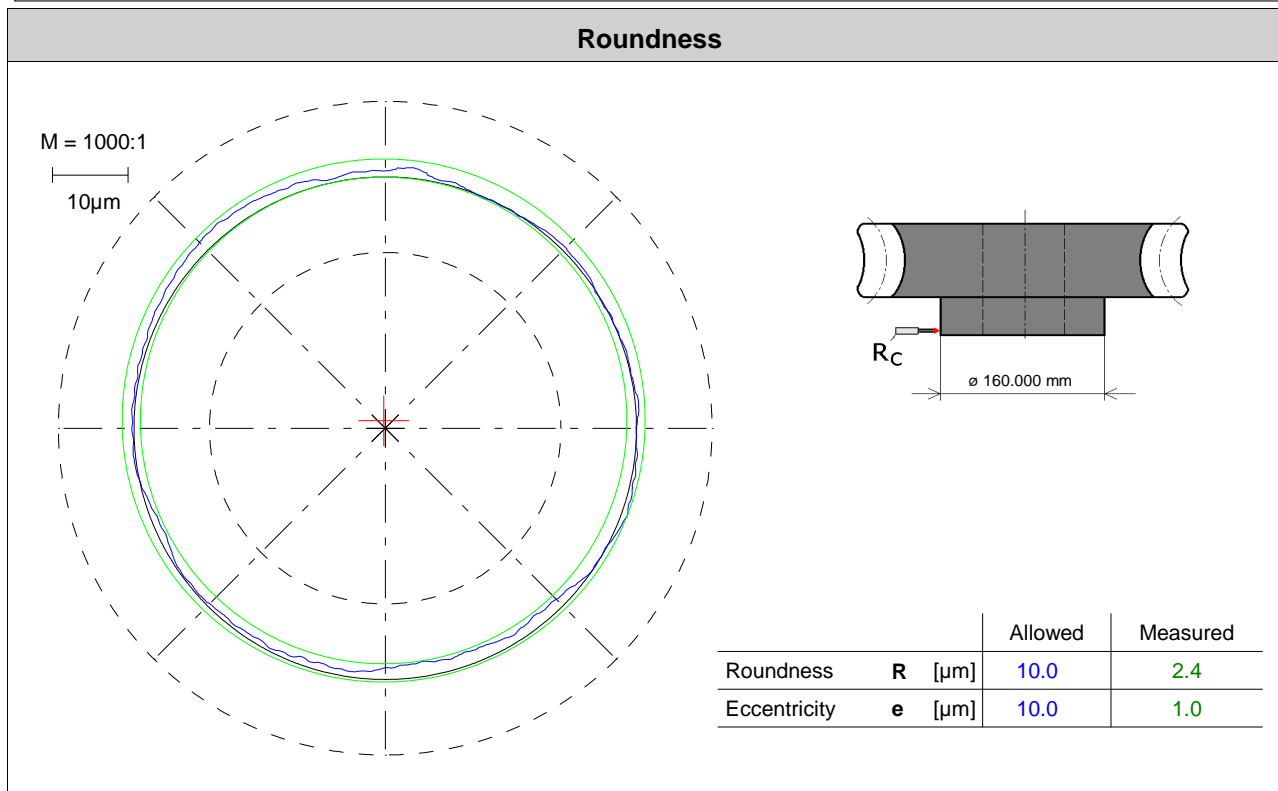

### Single flank composite measurement, Worm gears



OTT 2978 HR GEARTEC2



Worm	snek	Wormgear	kolo	Measured points	1000
Number of teeth	$z$	1 / R	Number of teeth	$z$	72
Number of teeth	$z$	1 / R	Number of teeth	$z$	72
Axial module	$m_x$	2.120	Pitch diameter	$d_m$	152.496 mm
Pressure angle	$\alpha_n$	15.0000°	Shaft angle	$W$	0.0000°
Pitch diameter	$d_m$	47.764 mm	Worm position	$M'_y$	14.000 mm
Centre distance	$a'$	100.000 mm	Worm position	$M'_z$	69.000 mm
Measuring speed	50rpm	Load torque	2.00 Nm	Note	Diplom thesis
				Date	06.08.2020 10:47
				Checked by	Petra Zdanska

$F_i', f_i', ["]$



$n_m = 1$

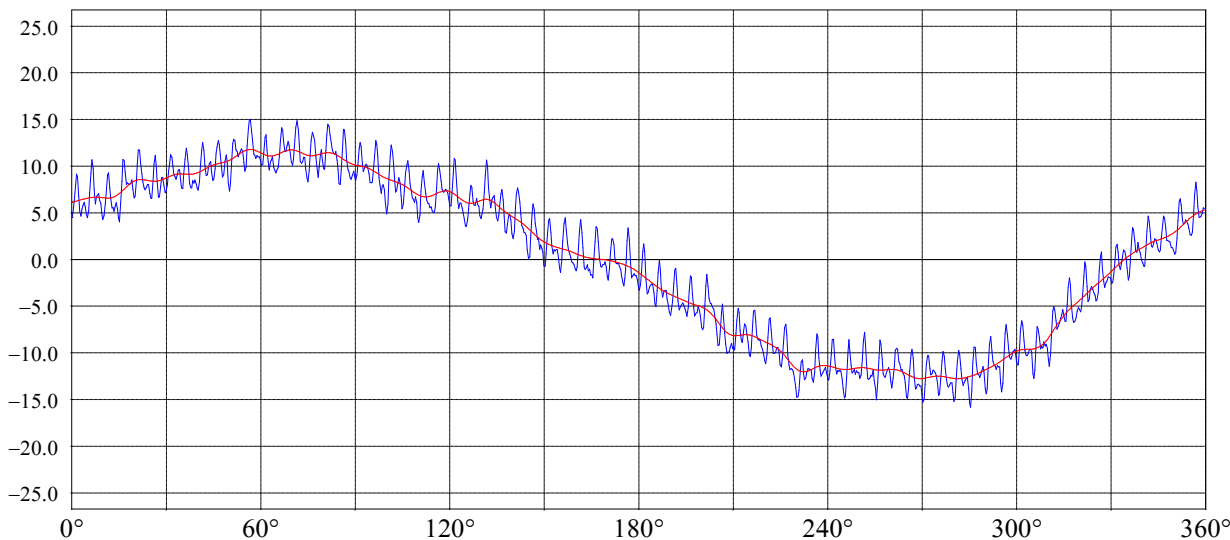

Left flank

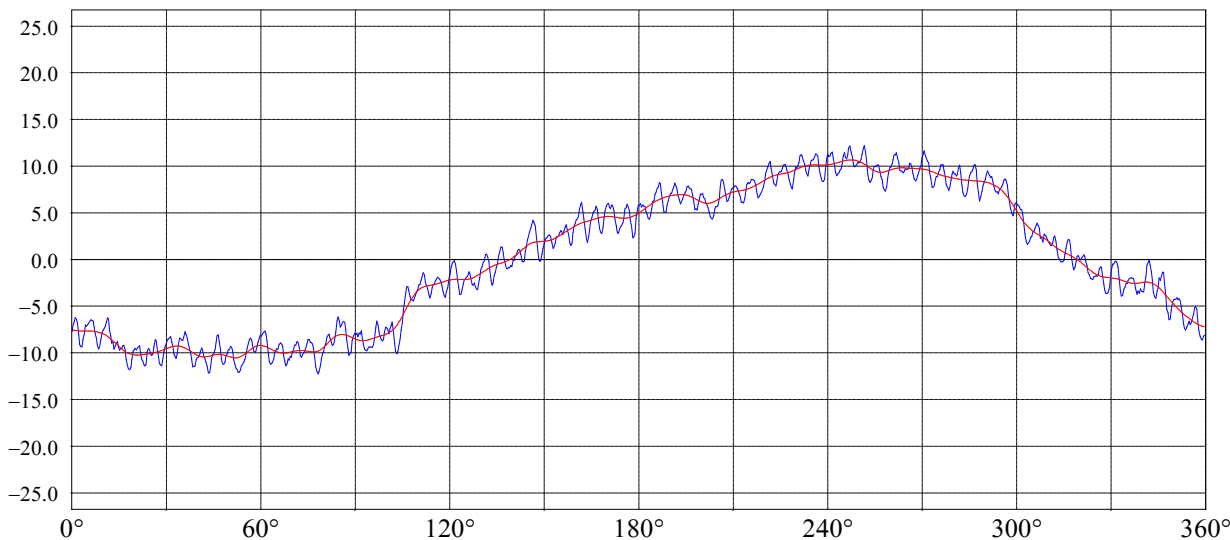

Right flank



Standard: DIN 3974	F-factor 25%	Allowed	$L$ Measured $R$
Total composite deviation	$F'_i$ ["]	30.0   2	30.8   3    24.3   2
Single flank composite dev.	$f'_i$ ["]	13.4   2	7.6   1    5.7   1
Average value	$f'_{i,m}$ ["]		5.4   1    3.0   1
Mean value	$f'_{i,max}$ ["]		7.8   1    7.3   1
Long wave component	$f'_l$ ["]		24.6    21.1
Short wave component	$f'_k$ ["]		6.5    3.8
Backlash - tangential	$\bar{j}$ [mm]	0.020 + 0.150	0.115

Single flank composite measurement, Worm gears						
		OTT 2978 HR GEARTEC2				
Worm	snek	Wormgear	kolo	Measured points	1000	
Number of teeth	$z$	1 / R	Number of teeth	$z$	72	Part No.
Axial module	$m_x$	2.120	Pitch diameter	$d_m$	152.496 mm	Contract No.
Pressure angle	$\alpha_n$	15.0000°	Shaft angle	$W$	0.0000°	Machine No.
Pitch diameter	$d_m$	47.764 mm	Worm position	$M'_y$	14.000 mm	Date 06/08/2020 12:20
Centre distance	$a'$	100.000 mm	Worm position	$M'_z$	69.000 mm	Checked by Petra Zdanska
Measuring speed	50rpm	Load torque	2.00 Nm	Note	Diplom thesis	

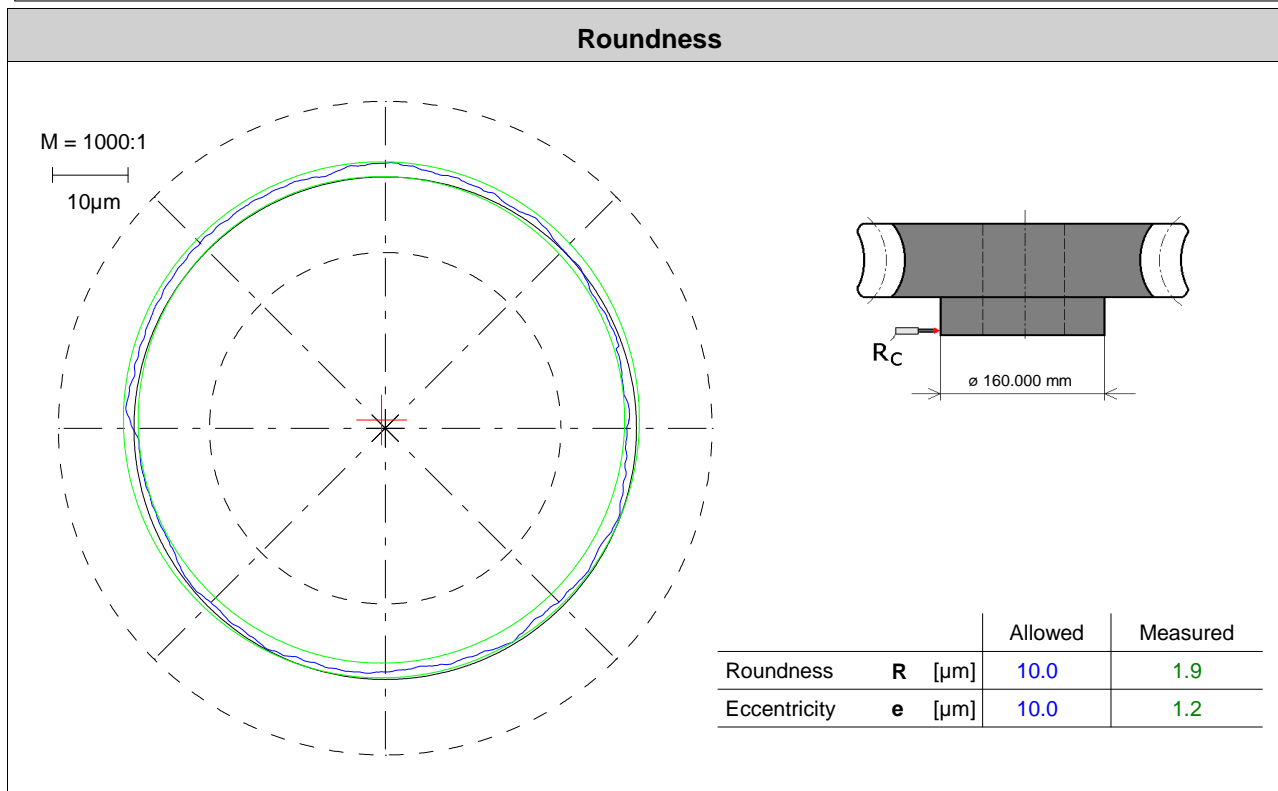



### Single flank composite measurement, Worm gears



OTT 2978 HR GEARTEC2



Worm	snek	Wormgear	kolo	Measured points	1000
Number of teeth	$z$	1 / R	Number of teeth	$z$	72
Number of teeth	$z$	1 / R	Pitch diameter	$d_m$	152.496 mm
Axial module	$m_x$	2.120	Shaft angle	$W$	0.0000°
Pressure angle	$\alpha_n$	15.0000°	Worm position	$M'_y$	14.000 mm
Pitch diameter	$d_m$	47.764 mm	Worm position	$M'_z$	69.000 mm
Centre distance	$a'$	100.000 mm	Load torque		2.00 Nm
Measuring speed		50rpm	Note		Diplom thesis

$F_i', f_i', ["]$



$n_m = 1$

Left flank

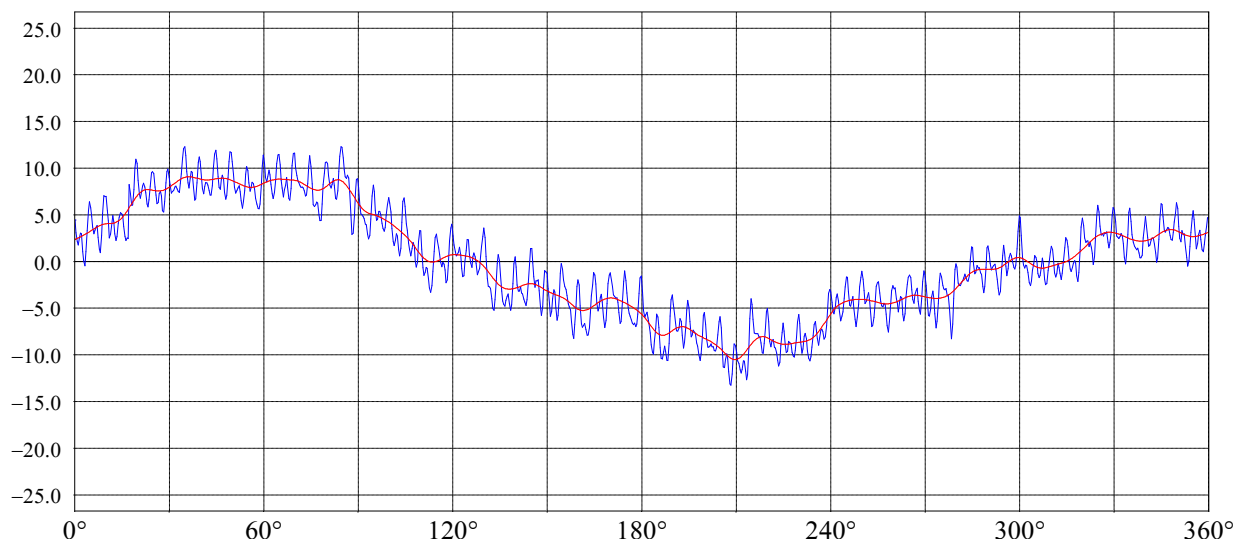

Right flank

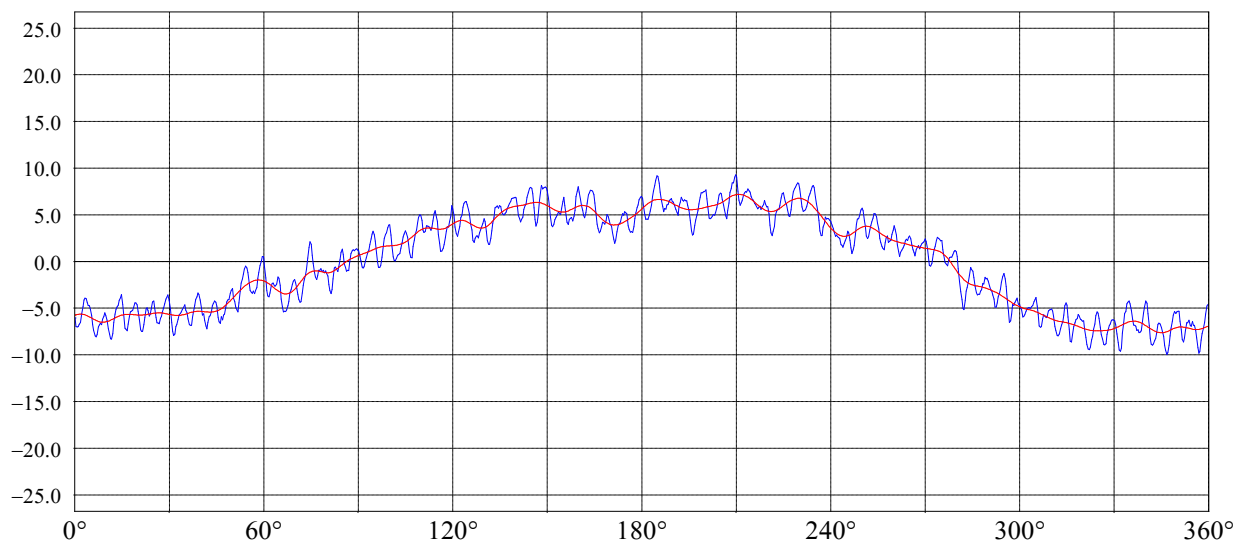

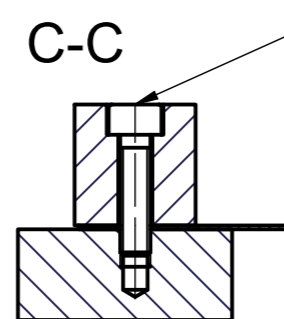
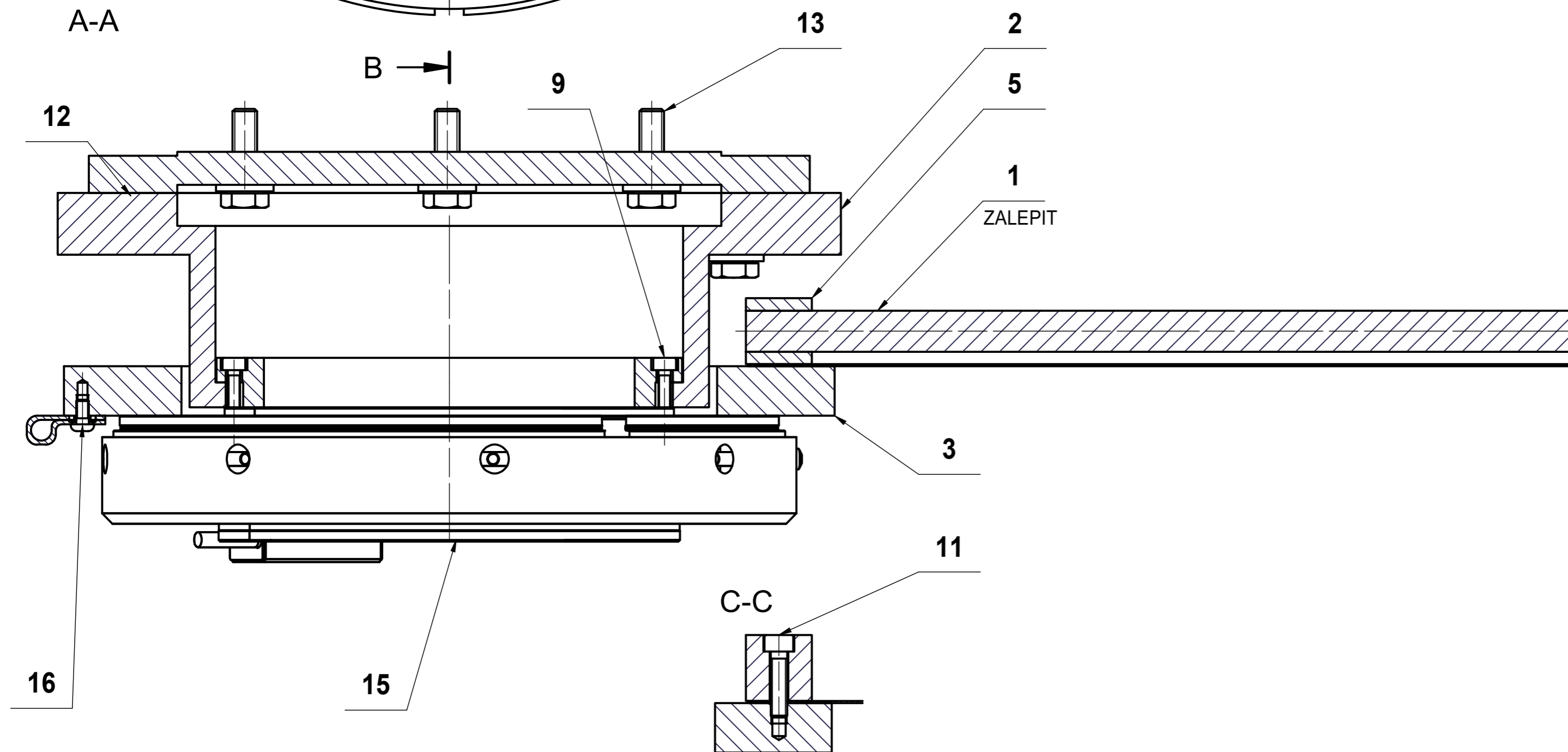
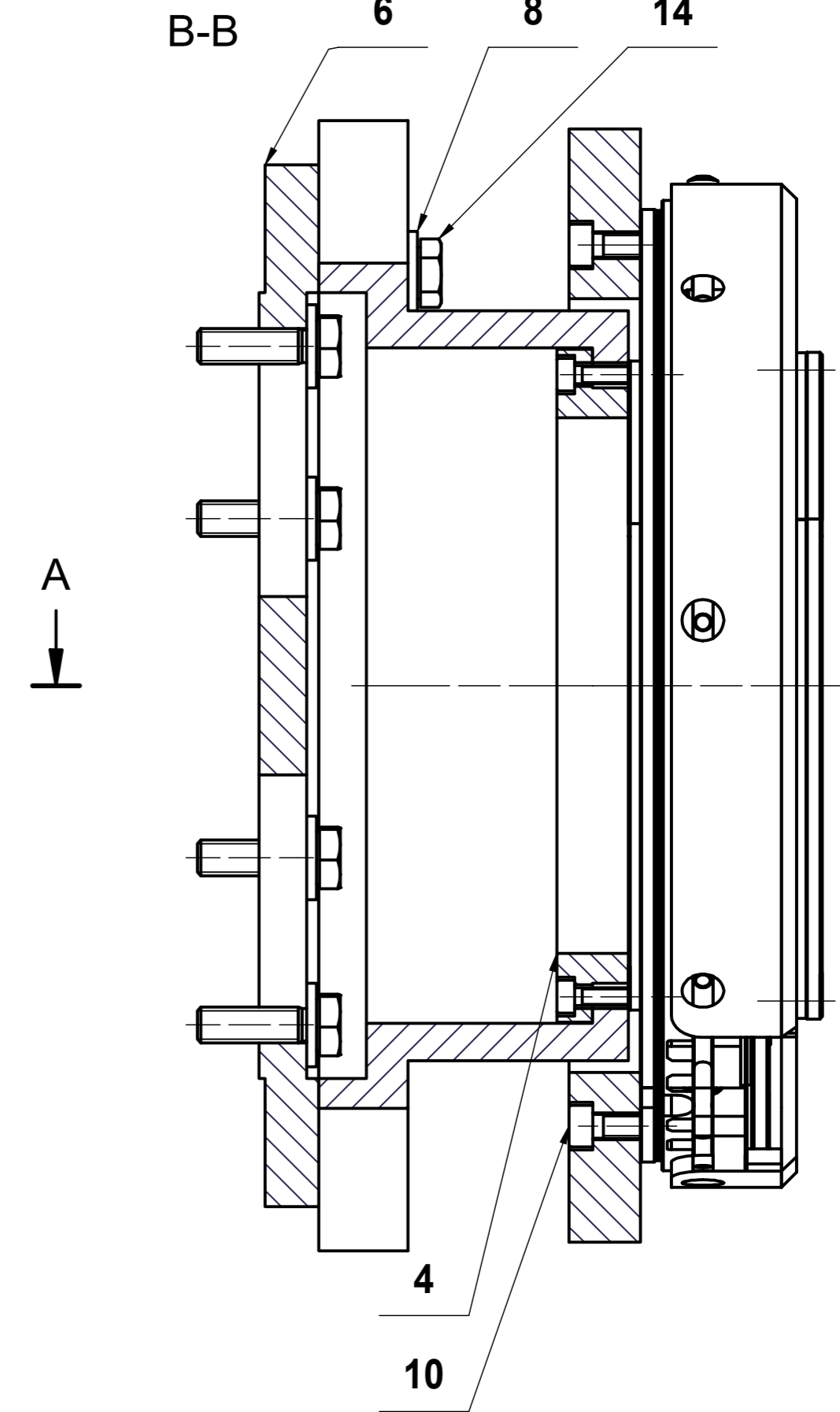
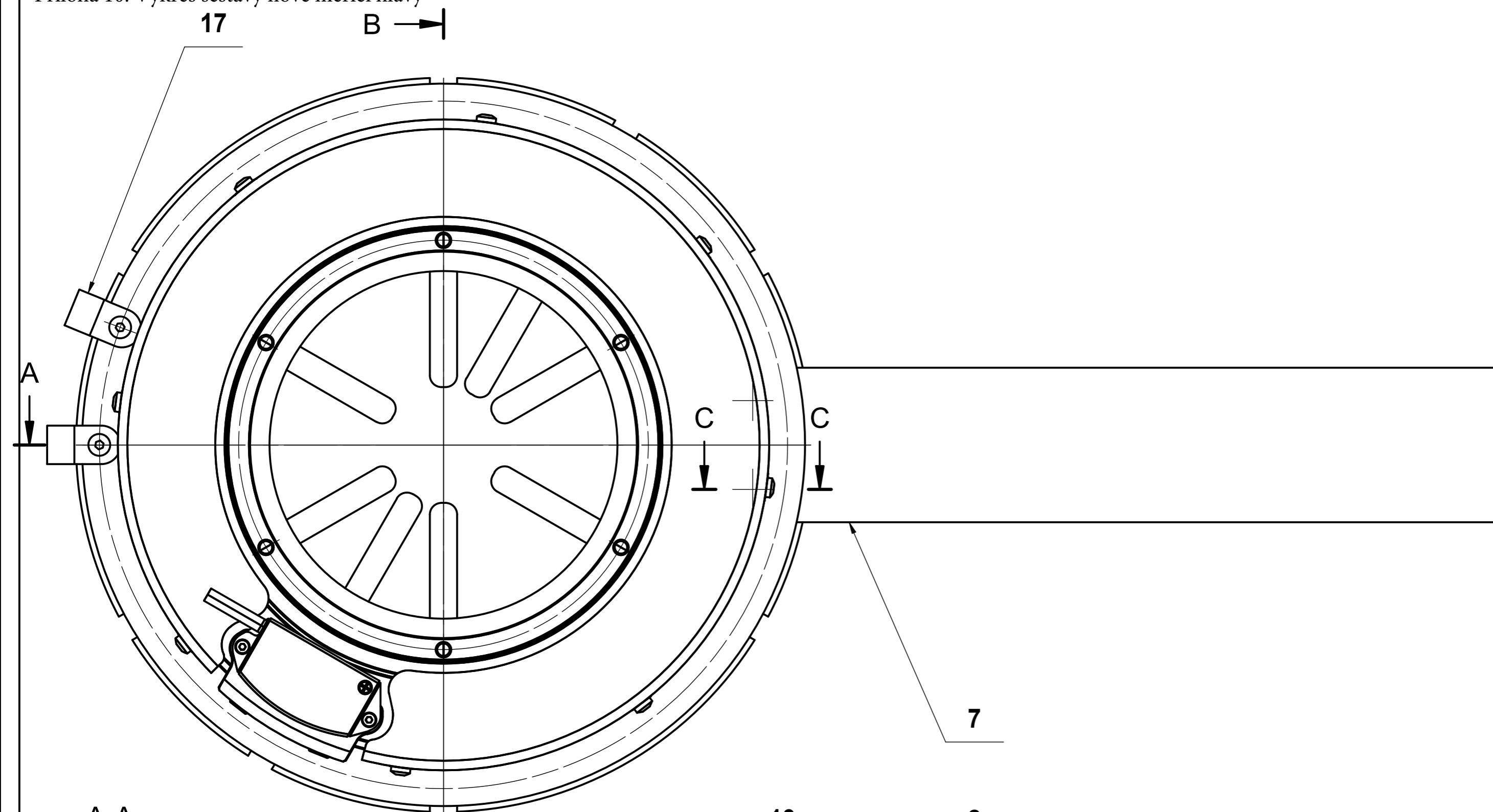

Standard: DIN 3974	F-factor 25%	Allowed	$L$ Measured $R$
Total composite deviation	$F'_i$ ["]	30.0   2	25.4   2    18.9   1
Single flank composite dev.	$f'_i$ ["]	13.4   2	7.8   1    5.4   1
Average value	$f'_{i,m}$ ["]		5.4   1    3.5   1
Mean value	$f'_{i,max}$ ["]		9.5   1    6.5   1
Long wave component	$f'_l$ ["]		19.5    14.9
Short wave component	$f'_k$ ["]		6.5    4.3
Backlash - tangential	$\bar{j}$ [mm]	0.020 + 0.150	0.111

Příloha 10: Výkres sestavy nové měřící hlavy



17	PRICHYTKA_KABELU	UC-0.5			UC - 0.5	2
16	ISO 7380-1 - M3 x 6	Šrouby s půlkulovou hlavou s vnitřním šestihranem			ISO 7380-1	2
15	ÚHLOVÝ SNÍMAČ	MRP 8080			HEIDENHAIN	1
14	DIN 933 - M6 x 22	Šestihranný šroub			DIN 933	6
13	DIN 933 - M6 x 20	Šestihranný šroub			DIN 933	6
12	DIN 913 - M8 x 10	Stavěcí šroub s vnitřním šestihranem			DIN 913	4
11	DIN 912 - M4 x 16	Šroub s válcovou hlavou			DIN 912	2
10	DIN 912 - M4 x 12	Šroub s válcovou hlavou			DIN 912	6
9	DIN 912 - M3 x 16	Šroub s válcovou hlavou			DIN 912	12
8	DIN 125 - A 7,4	Podložka			DIN 125	12
7	280-2932-4	PLECH	0,5-40x200	OCEL		1
6	190-1665-4	PŘÍRUBA	Ø175x10	LITINA		1
5	190-1664-4	DESTIČKA	16x16-36	11 600		1
4	190-1663-4	STŘEDÍČÍ PŘÍRUBA	Ø113-18	11 600		1
3	190-1660-4	PŘÍRUBA	Ø185-12	AL		1
2	190-1659-4	PŘÍRUBA	Ø190-52	LITINA		1
1	140-1102-4	TYČ Ø10	Ø10-200	HABERKORN		1
Poz	Číslo výkresu	Název	Rozměr	Materiál	Norma	Mn
MATERIÁL		HMOT_KG	SESTAVA	<b>geartec</b>		
ROZMĚR		VYPRACOVAL Žďánská	DATUM 16.10.2020			
STROJ		SKUPINA KONTROL.SNÍMAČ	<b>110-2593-2</b>			
MÉR. 1:1	NÁZEV KONTROLNÍ SNÍMAČ	ČÍSLO VÝKRESU				

Single flank composite measurement, Measuring of gearing					
					
Name	GTM NEW	Number of measured revolutions	1	Part No.	
Speed	1	FFT production speed		Date	08.01.2021 10:05
1st stage	z= 20/ 20 m=10,000	Measuring speed	5rpm	Checked by	
2nd stage		Measured points	2000	Note	
3rd stage		Load torque	0,00 Nm	Contract No.	
4th stage		Speed ratio i	1,00000	Order No.	
5th stage				Additional information	

### Roundness

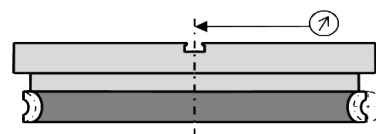
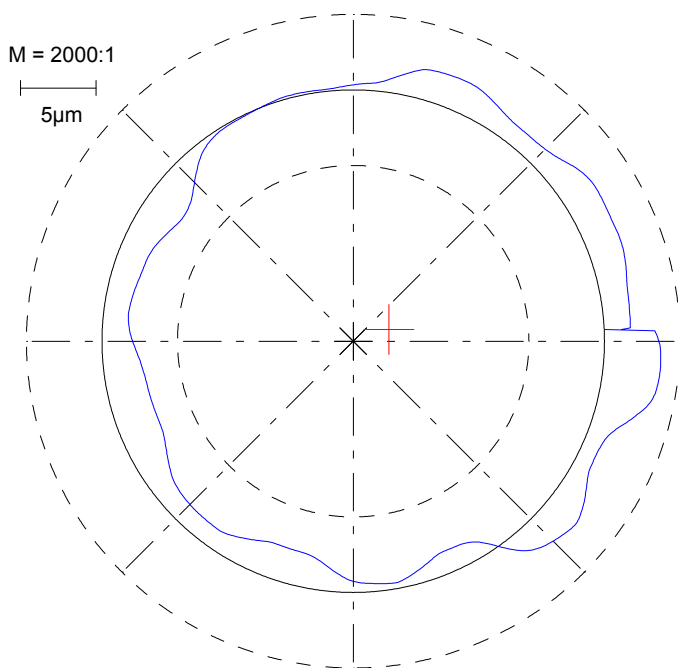

			Allowed	Measured
Roundness	R	[µm]	0,0	3,2
Eccentricity	e	[µm]	0,0	2,5

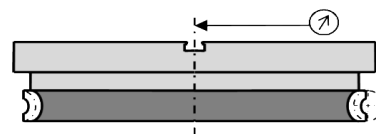
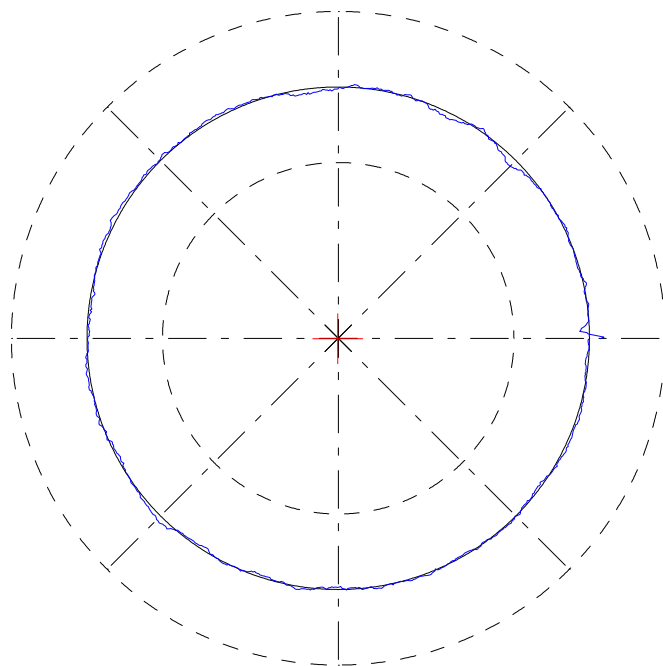

			Allowed	Measured
Roundness	R	[µm]	0,0	1,6
Eccentricity	e	[µm]	0,0	0,0

**Single flank composite measurement, Measuring of gearing**



Name	GTM NEW	Number of measured revolutions	1	Part No.
Speed	1	FFT production speed		Date 08.01.2021 10:05
1st stage	z= 20/ 20 m=10,000	Measuring speed	5rpm	Checked by
2nd stage		Measured points	2000	Note
3rd stage		Load torque	0,00 Nm	Contract No.
4th stage		Speed ratio i	1,00000	Order No.
5th stage				Additional information

**Fi' - Total composite deviation, [ " ]**

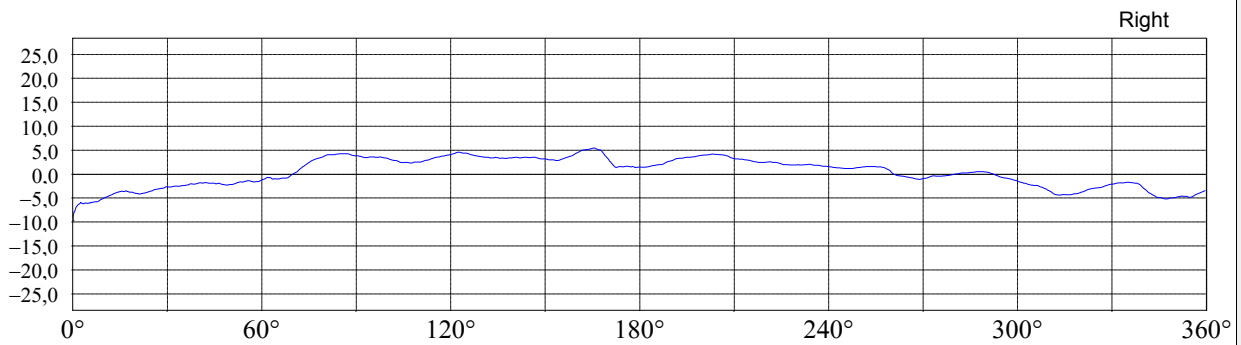

**fi' - Long wave component, [ " ]**

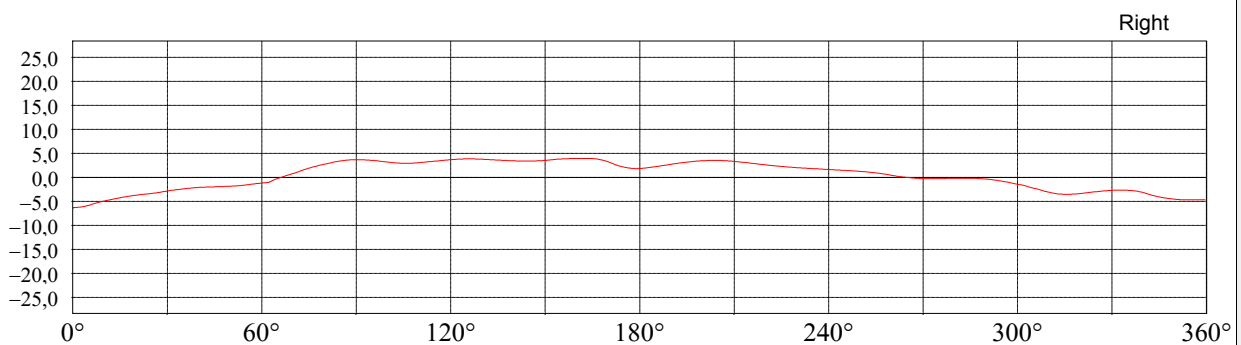

**fk' - Short wave component, [ " ]**

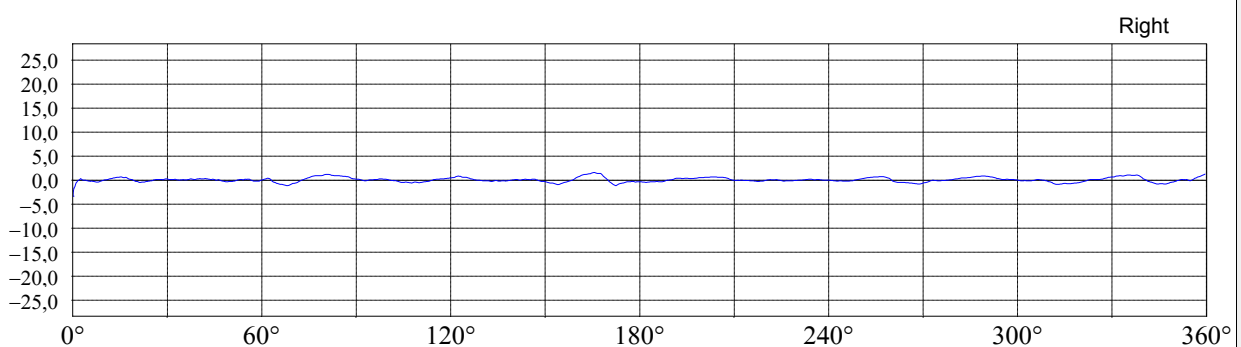

Tolerances (F-factor 25%)				Allowed	Measured
Total composite deviation	$F'_i$	[ " ]		103,1	12,4
Single flank composite dev.	$f'_i$	[ " ]		103,1	5,4
Mean value	$f'_{i,m}$	[ " ]			2,1
Max value	$f'_{i,max}$	[ " ]			5,4
Long wave component	$f'_l$	[ " ]		103,1	10,3
Short wave component	$f'_k$	[ " ]		103,1	2,5
Backlash	j	[ " ]			