

REVISIONS					
ZONE	REV	ECN	DESCRIPTION	DATE	APP'D
-	A	-	RELEASED FOR PROTOTYPE	2020JUL09	PAT KAM JAM

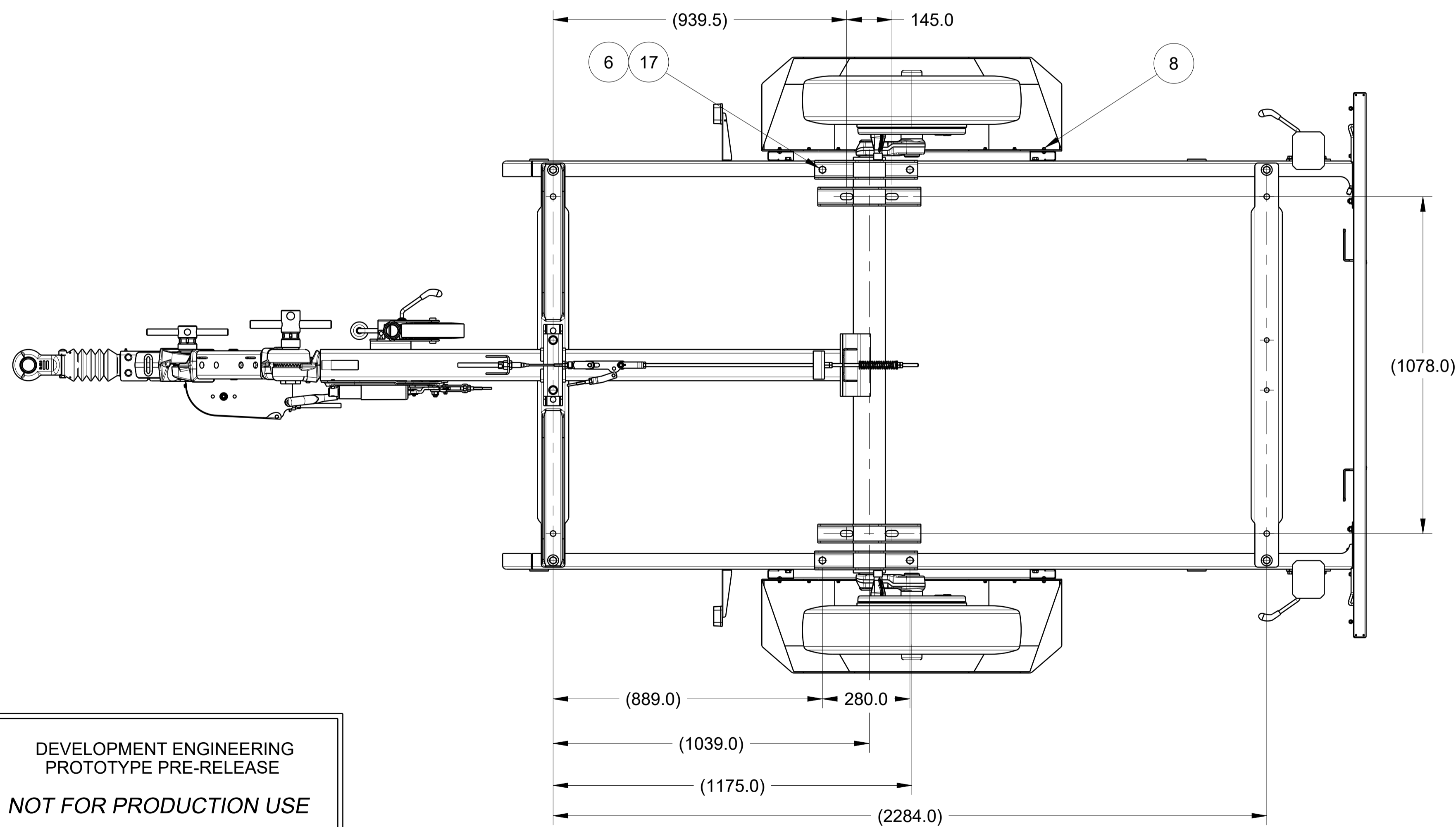
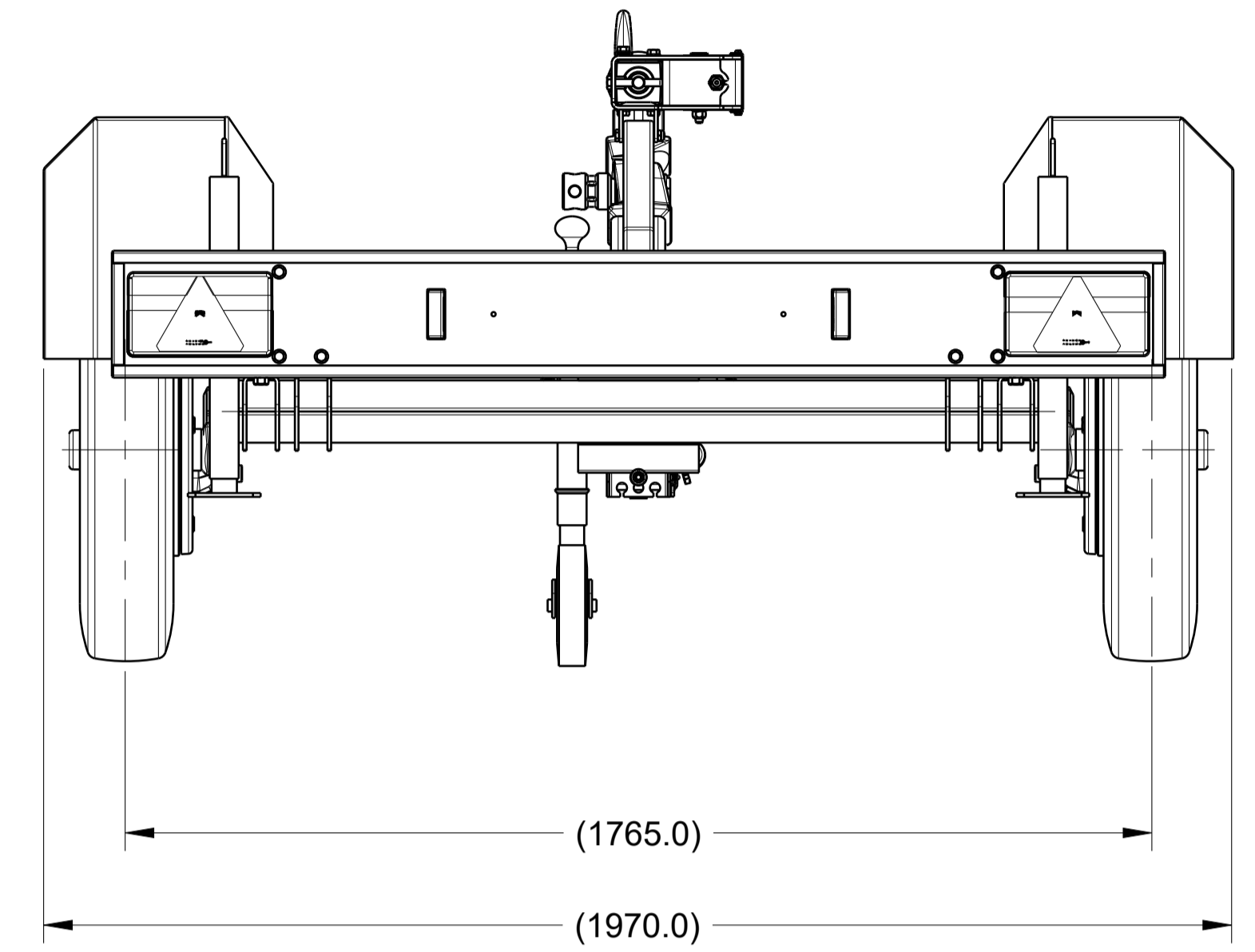
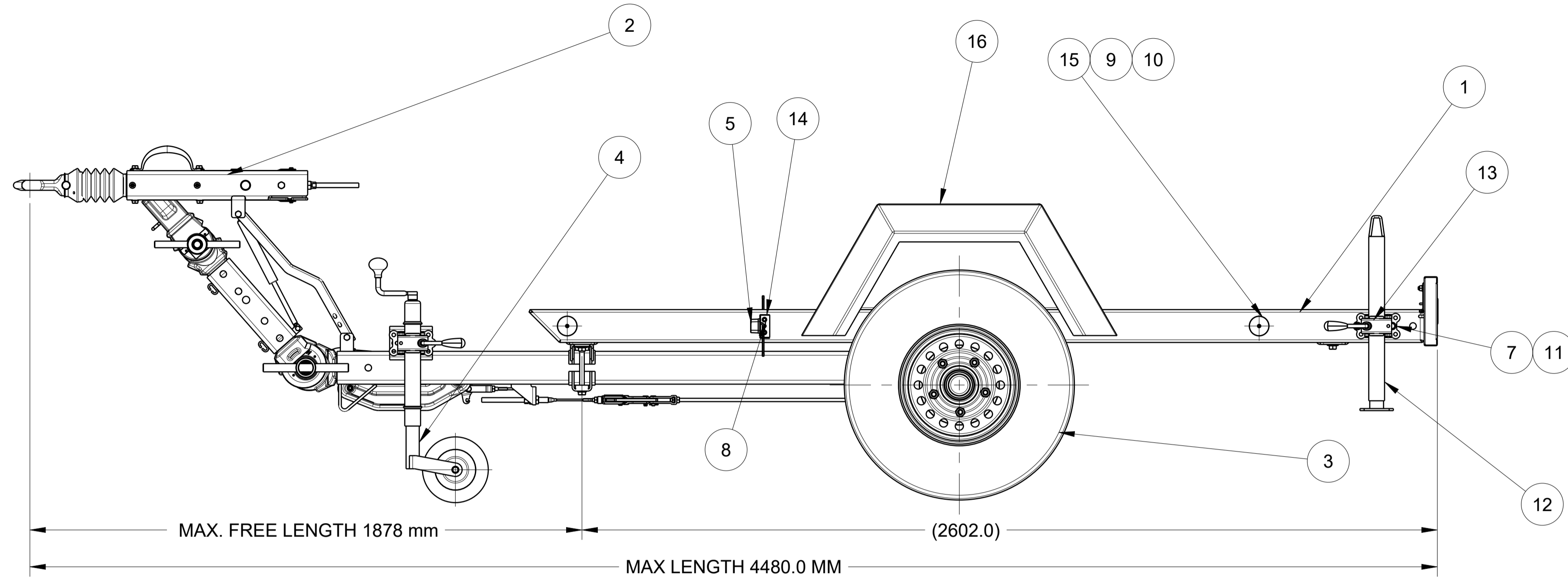

DEVELOPMENT ENGINEERING  
 PROTOTYPE PRE-RELEASE  
**NOT FOR PRODUCTION USE**

ITEM	QTY.	PART NO.	DESCRIPTION	NOTES	SHT
18	4	96752589	96752589ww.prt, NUT, FLANGE M6-1.0		
17	4	96747142	SCREW, M16-2.0 X 40 LG FLANGE HEX HD W/THD LOCK ZINC		
16	2	46828293	FENDER, PLASTIC		
15	4	46828291	REFLECTOR, CIRCULAR AMBER		
14	2	46828290	HOLDER, FRONT LIGHT		
13	3	46828287	HOLDER		
12	2	46571999	JACK, ASSY		
11	4	92473594	NUT, HEX FLG M10		
10	4	92271923	RIVET, 3/16 X 5/8		
9	4	88111091	WASHER, FLAT 3/16ID X1.0D		
8	18	23230162	SCREW, M6-1.0 X 12 LG FLANGE HEX HEAD ZINC		
7	4	92472638	SCREW, FLANGED HD M10X20		
6	4	36879211	NUT, M16-2.0 HEX FLANGE CLASS 10 ZINC		
5	2	46698057	LAMP, POSITION WHITE - LED		
4	1	22053763	JOCKEY WHEEL ASSY		
3	2	46828286	WHEEL & TIRE ASSY, 205/70R15 124J		
2	1	46828285	RUNNING GEAR, VARIABLE BRAKE - G100		
1	1	46826986	FRAME, TRAILER G100		

PARTS LIST

TOLERANCES	PROPRIETARY NOTICE
UNLESS OTHERWISE SPECIFIED, TOLERANCES ON DIMENSIONS ARE AS SPECIFIED ON DRAWING 36865731	THIS DRAWING CONTAINS CONFIDENTIAL AND TRADE SECRET INFORMATION, IS THE PROPERTY OF DOOSAN PORTABLE POWER AND IS GIVEN TO THE RECEIVER IN CONFIDENCE. THE RECEIVER BY RECEPTION AND RETENTION OF THE DRAWING ACCEPTS THE DRAWING IN CONFIDENCE AND AGREES THAT, EXCEPT AS AUTHORIZED IN WRITING BY DOOSAN PORTABLE POWER IT WILL (1) NOT USE THE DRAWING COPY THEREOF OR THE CONFIDENTIAL OR TRADE SECRET OR ANY INFORMATION THEREIN; (2) NOT COPY THE DRAWING; (3) NOT DISCLOSE TO OTHERS EITHER THE DRAWING OR THE CONFIDENTIAL OR TRADE SECRET INFORMATION THEREIN; AND (4) UPON COMPLETION OF THE NEED TO RETAIN THE DRAWING, OR UPON DEMAND, RETURN THE DRAWING, ALL COPIES THEREOF, AND ALL MATERIAL COPIED THEREFROM.
UNLESS OTHERWISE SPECIFIED, ALL DIMENSIONS ARE IN MILLIMETERS.	

WARNING: THE EXPORT OR REEXPORT OF THIS DRAWING OR A PRODUCT PRODUCED BY THIS DRAWING IS SUBJECT TO U.S. EXPORT ADMINISTRATION REGULATIONS AND OTHER APPLICABLE GOVERNMENT RESTRICTIONS OR REGULATIONS.

COPYRIGHT © 2020 DOOSAN PORTABLE POWER ALL RIGHTS RESERVED

DO NOT SCALE DRAWING

**DOOSAN**  
 Portable Power

THIRD ANGLE PROJECTION

WELD SYMBOLS PER ANSI/AWS A2.4

CAD GENERATED DRAWING, NO MANUAL REVISIONS ALLOWED

UNLESS OTHERWISE SPECIFIED, REMOVE ALL BURRS AND SHARP CORNERS

SIZE: **A1** ESTIMATED WEIGHT: **411** DWG NO.: **46828265** REV: **1**

SCALE: 0.1 UNIT: G100 SHEET 1 OF 1

DRAWING CONFORMS TO ASME Y14.5 - 2009

**RUNNING GEAR, ASSEMBLY**