

SCALE 2.000

<p>WARNING</p> <p>THE EXPORT OR REEXPORT OF THIS DRAWING OR A PRODUCT PRODUCED BY THIS DRAWING IS SUBJECT TO U.S. EXPORT ADMINISTRATION REGULATIONS AND OTHER APPLICABLE GOVERNMENTAL RESTRICTIONS OR REGULATIONS.</p> <p>COPYRIGHT</p> <p>ORIGINALLY CREATED AND REVISED IN THE YEARS AS IDENTIFIED IN THE RELEASING ECN. BOBCAT COMPANY RESERVES ALL RIGHTS.</p> <p>PROPRIETARY NOTICE</p> <p>THIS DOCUMENT CONTAINS CONFIDENTIAL AND TRADE SECRET INFORMATION, IS THE PROPERTY OF BOBCAT COMPANY, AND IS GIVEN TO THE RECEIVER IN CONFIDENCE. THE RECEIVER, BY RECEIPT AND RETENTION OF THE DOCUMENT, ACCEPTS THE DOCUMENTS IN CONFIDENCE AND AGREES THAT, EXCEPT AS AUTHORIZED IN WRITING BY BOBCAT COMPANY, IT WILL (1) NOT USE THE DOCUMENT OR ANY COPY THEREOF OR THE CONFIDENTIAL OR TRADE SECRET INFORMATION THEREIN; (2) NOT COPY THE DOCUMENT, (3) NOT DISCLOSE TO OTHERS EITHER THE DOCUMENT OR THE CONFIDENTIAL OR TRADE SECRET INFORMATION THEREIN; AND (4) UPON COMPLETION OF THE NEED TO RETAIN THE DOCUMENT, OR UPON DEMAND, RETURN THE DOCUMENT, ALL COPIES THEREOF, AND ALL MATERIALS COPIED THEREFROM.</p>	<p>MM</p> <p>UNLESS OTHERWISE SPECIFIED MACHINED SURFACE MAX. ROUGHNESS 3.2 μm</p>		<p>TOLERANCES</p> <p>UNLESS OTHERWISE SPECIFIED</p> <p>SEE BOBCAT STANDARD DE-L FOR SHEETMETAL BEND RAD. TOLERANCE</p> <p>X ± 2.5 X.X ± 1.0 X.XX $\pm .25$</p> <p>ANGULAR $\pm 1^\circ$ FILLETS & RADII ± 1.5</p>	
	<p>THIRD ANGLE PROJECTION</p>	<p>WELD SYMBOLS PER ANSI/AWS A2.4</p>	<p>Bobcat Company</p> <p>WEST FARGO, NORTH DAKOTA, USA</p>	
<p>INITIAL ECN: .</p>		<p>TITLE:</p>		
<p>WT 1.474 kg</p>	<p>S/A 376.45 cm²</p>	<p>SHT 2/2</p>	<p>DWG. NO. PRIPRAVOK_A</p>	

0				
REV	DESCRIPTION	CHG NOTICE	DWN	SHEET



Bobcat®

PART NUMBER		EQUIPMENT	002	srpna 02, 2020	11:14 odp.
PART NAME	PRIMERNY PRIPRAVOK A	PART ID	001	OPERATOR	4001
MEASUREMENT ORDER	0000	M. PROGRAM	P01	M. PROGRAM REV	R001

006_A_DRW_PSD_001	MM		0.1	A	ASME_Y14_5
P002	0.037				

005_A_DRW_PAR_001	MM		0.1	A	
P002	0.019				

004_A_DRW_FL_A_001	MM		0.1		
P002	0.002				

	MM	008_A_DRW_DIA_001 - K003			
AX NOMINAL	MEAS	DEV	OUTTOL		
D	757.600	754.979	-2.621 2.571		

	MM	001_A_DRW_DIA_001 - K001_A			
AX NOMINAL	MEAS	DEV	OUTTOL		
D	14.350	14.321	-0.029 0.000		

003_A_DRW_FL_A_001	MM		0.1		
P001_AUT	0.003				

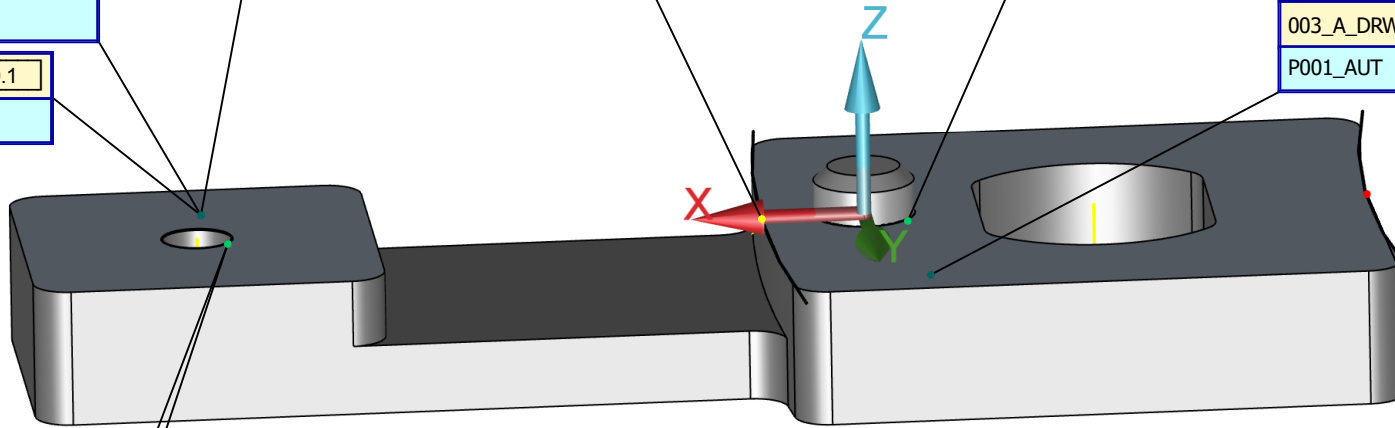

	MM	002_A_DRW_DIA_001 - K002_A			
AX NOMINAL	MEAS	DEV	OUTTOL		
Z	0.000	-0.028	-0.028 0.000		
D	10.000	10.000	0.000 0.000		

	MM	009_A_DRW_DIA_001 - K004			
AX NOMINAL	MEAS	DEV	OUTTOL	MIN	
D	584.600	585.168	0.568 0.518	0.000	

007_A_DRW_POS_001	Position	MM		0.1	A B
K002_A	0.035				

