

Ra 6,3 (Ra 1,6 Ra 3,2)

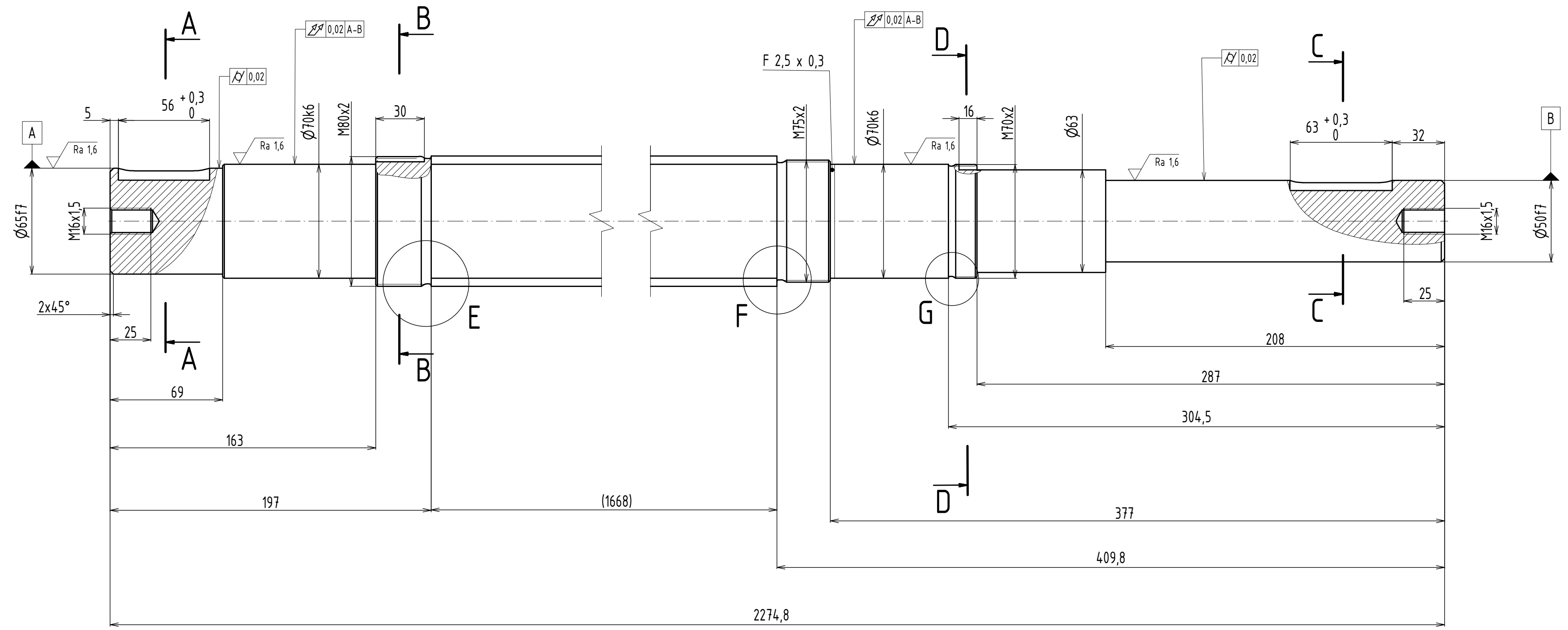

A-A (1:2)

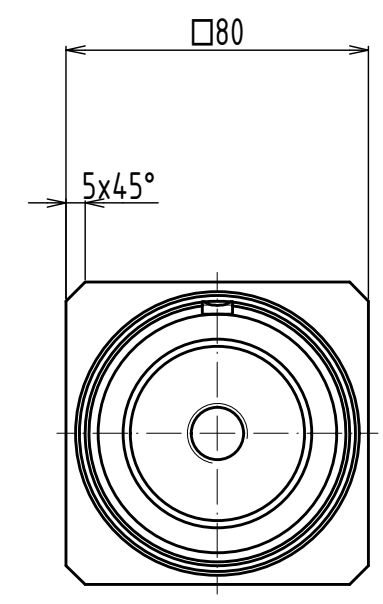
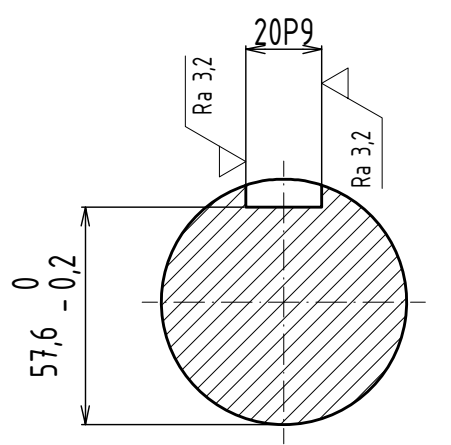

B-B (1:2)

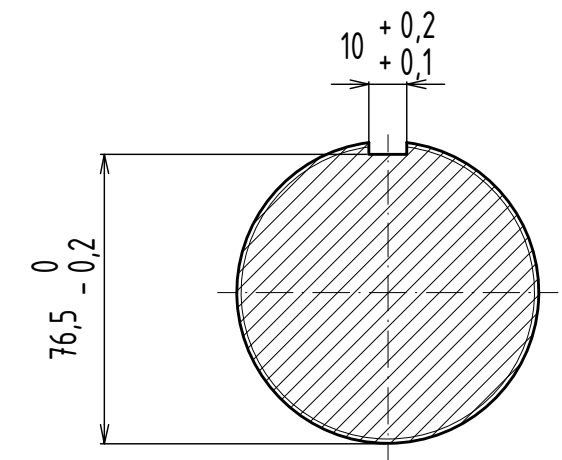

C-C (1:2)

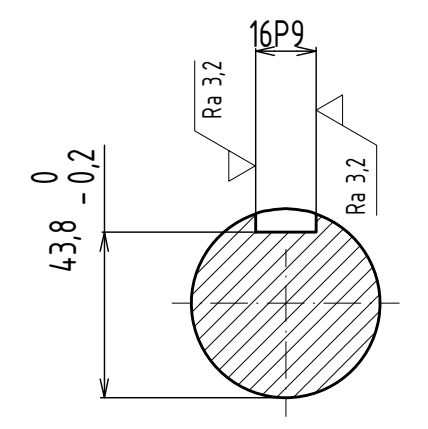

D-D (1:2)

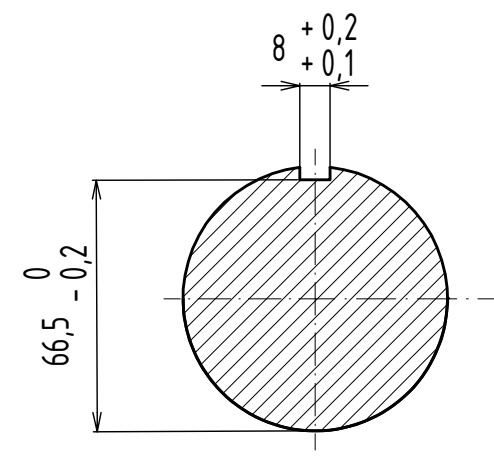

E (1:1)

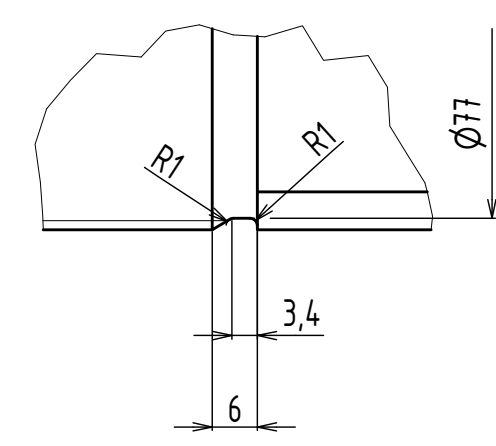

F (1:1)

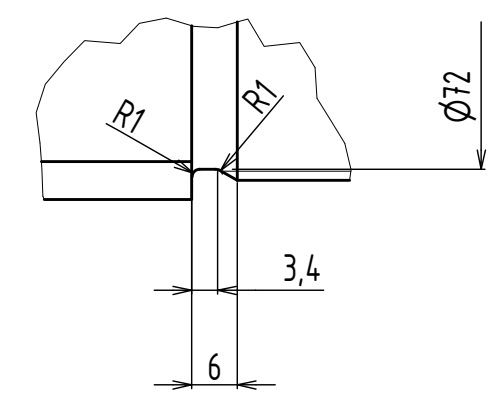

G (1:1)

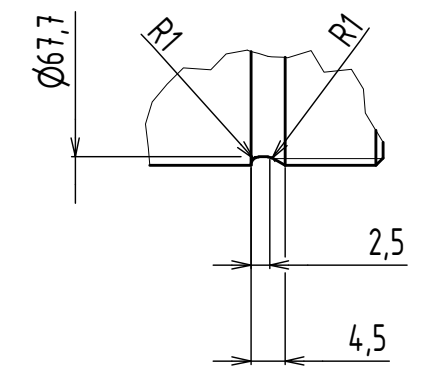

NEKOTOVANÉ ZKOSENÍ 1x45°

C. NADSESTAVY / PARENT ASSEMBLY

D				
C				
B				
A		19.6.2020	DIVOK	ORIGINAL / ORIGINAL RELEASE
REV./REV	MISTO/BLOCK	DATUM / DATE	KRESLIL / DRAWN BY	POPIS ZMENY / DESCRIPTION
MATERIAL / MATERIAL		POLOTOVAR / SEMI-FINISHED PRODUCT		
16MnCr5 EN 10059		TYČ ČTVERCOVÁ 90 x 2280		
MERITKO / SCALE	KONTRÓLOVAL / CHECKED BY		SCHVALIL / APPROVED BY	TOLERANCE / TOLER. PRESNOST / GEN. TOL.
1:2	CISTA HMOTNOST [kg] / NET WEIGHT [kg]		ISO 8015	ISO 2768-mK
		97,9	NAZEV / TITLE	
			VSTUPNÍ HŘÍDEL	
AURORA ENGINEERING		LIST / PAGE	REVIZE / REV	CISLO / DWG NO
DESIGNS FOR YOUR NEEDS		1 / 1		500-021-003
				FORMAT / SIZE
				A2