

2. MOTOR DA1-132LO23R SE NACHÁZÍ NA PROTOTYPOVÉ ZKUŠEBNĚ
 1. OBĚ ČÁSTI SPOJKY LIŠOVAT ZÁROVEN S ČELEM HRÍDELE

Poz	Ks	Nazev	Rozmer	Material	Norma	C. vykresu	Poznámka
37	4	ČEP	TYC KR 25 ATEST	42CrMo4+QT	EN 10060	P42632_C	
36	2	PODLOZKA POD MOTOR	TYC KR 100	S355J2	EN 10060	P42627_C	
35	2	PERO 28H9X16X 80				132032	ČSN 02 2575
34	2	SROUB M 10X 20				10052097	ČSN EN ISO 1207
33	8	PODLOZKA 16				211312	ČSN 02 1740
32	10	SROUB M 16X 45				316953	ČSN EN ISO 4762
31	22	SROUB M 20X 50				317461	ČSN EN ISO 4762
30	22	PODLOZKA 21				302329	ČSN EN ISO 7089
29	10	PODLOZKA 17				317460	ČSN EN ISO 7089
28	4	ZAVES VLBG 251 M20				10044710	
27	6	SROUB M 8X 35				125182	ČSN EN ISO 4762
26	3	SROUB M 10X 35				322728	ČSN EN ISO 4762
25	4	SROUB M 16X 40				300505	ČSN EN ISO 4762
24	4	SROUB M 8X 20				116779	ČSN EN ISO 4762
23	4	KOLIK 10X 40				10035862	ČSN EN ISO 8735
22	1	KOLIK 10X 32				328275	ČSN EN ISO 8735
21	4	MATICE M 12				308646	ČSN EN ISO 4032
20	4	SROUB M 12X 90				317818	ČSN EN ISO 4762
19	1	Kolik 10x32-A-5l - UPRAVA	KOLIK 10X 32		DIN 7979	P42371_C	ČSN EN ISO 8735
17	2	KUN DREVENY 500x368x200	KUN DREVENY 500x368x200			P42391_C	
16	3	KUN DREVENY 500x193x200	KUN DREVENY 500x193x200			P42390_C	
15	2	RAMECEK 40x25-1220	TYC PLO 40X25	11375.0	425522.10	P42389_C	
14	2	RAMECEK 40x25-2700	TYC PLO 40X25	11375.0	425522.10	P42388_C	
13	1	ZUBOVA SPOJKA - UPRAVA	SPOJKA ZUBOVA ZK 50-1 KWD			P42392_C	
12	2	STUL KLADKY OBROBENI	SVAREK P26427 stul. kladky			P26428	
11	1	STOJAN MOTORU OBROBENI	SVAREK P26440 stojan motoru			P26441	
10	1	ZAVESKA SE SILENTBLOKEM				P36874_A	
9	2	PODLOZKA POD MOTOR	TYC KR 100	S355J2	EN 10060	P42367_C	
8	1	PRIRUBA SPOJKY	TYC KR 160 ATEST	S355J2	EN 10060	P36909_A	
7	1	PRIRUBA	TYC KR 160 ATEST	S355J2	EN 10060	P36911_A	
6	1	PIVKO HRIDELE	TYC KR 90	S355J2	EN 10060	P36912_A	
5	4	KOLIK 10X 40 - UPRAVA	KOLIK 10X 40		DIN 7979	P42381_C	ČSN EN ISO 8735
4	1	ZAVESKA NASTAVEC OBROBENI	SVAREK P36907_h zaveska nast.			P36908_A	
3	1	ZAVESKA OBROBENI	SVAREK P36894_A zaveska			P36895_A	
2	2	ROLNÝ-SESTAVA				P26443	
1	1	DESKA	VPALEK P70 080 2600x200	S355J2	EN 10029 A	P12807	

Dimension / Rozměr: Material / Materiál: Weight net / Hmotnost čistá: 1941.1 kg
 Weight gross / Hmotnost hrubá: 1941.1 kg
 Projection method: First angle projection
 Scale / Měřítko: 1:5
 Drawn / Nalímal: mcvikyr
 Type / Typ: TRAM
 Checked / Kontroloval: jspulak
 Quality standard / Standard kvality:
 Approved / Schválil: 06.02.2020
 Remark / Poznámka:
 Title / Název: PRIPRAVEK ZABIHACI
 Drawing Number / Číslo výkresu: V-5123
 Revision / Revize: #C
 Sheet / List: 1/3
 Date / Datum: A1
 WIKOV
 This drawing is property company WIKOV and shall not be copied, altered or communicated to a third party without approval of the owner.
 Tento výkres je vlastnictvím společnosti WIKOV a nesmí být kopírován, upraven nebo poskytnut třetí straně bez souhlasu vlastníka.

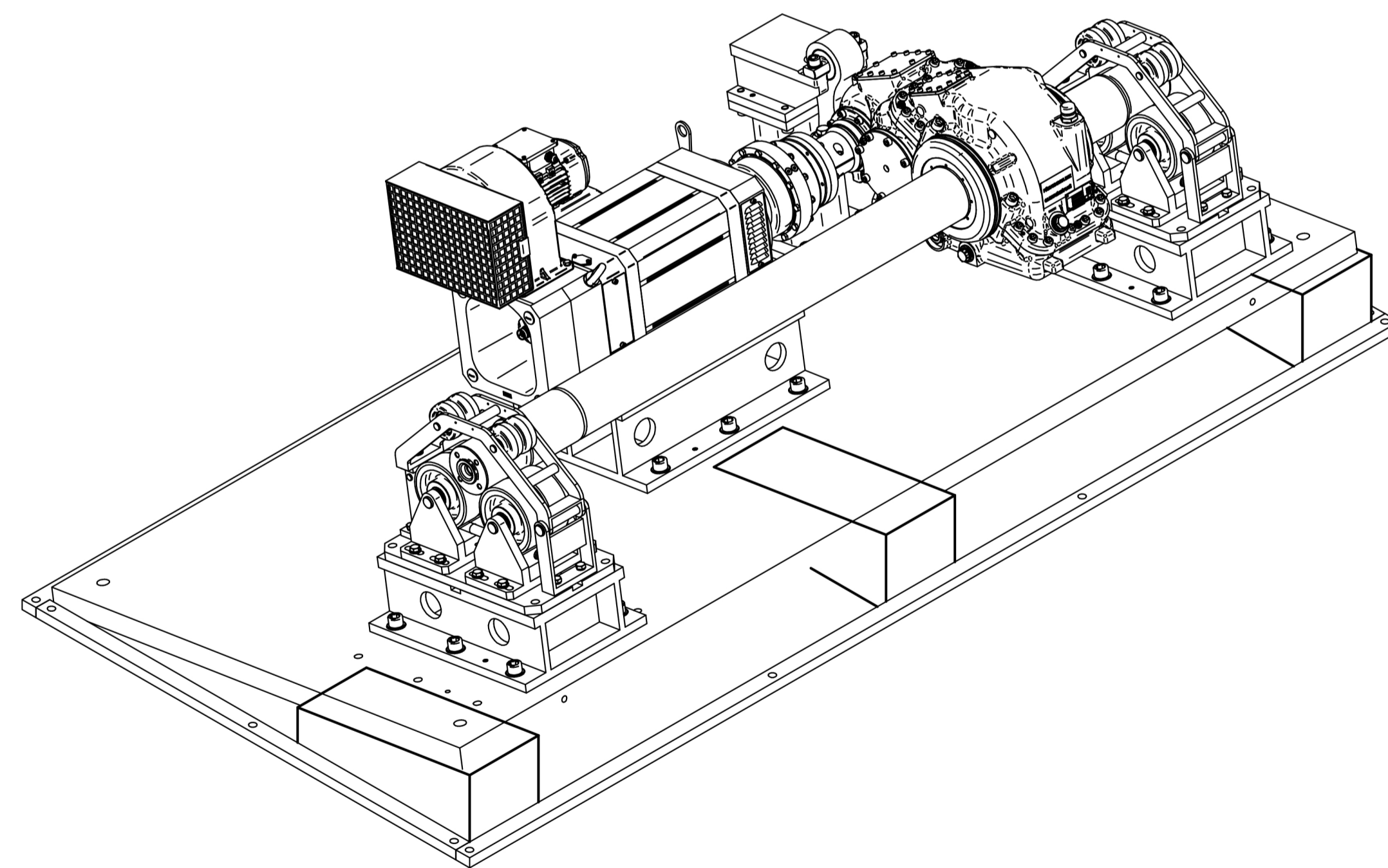
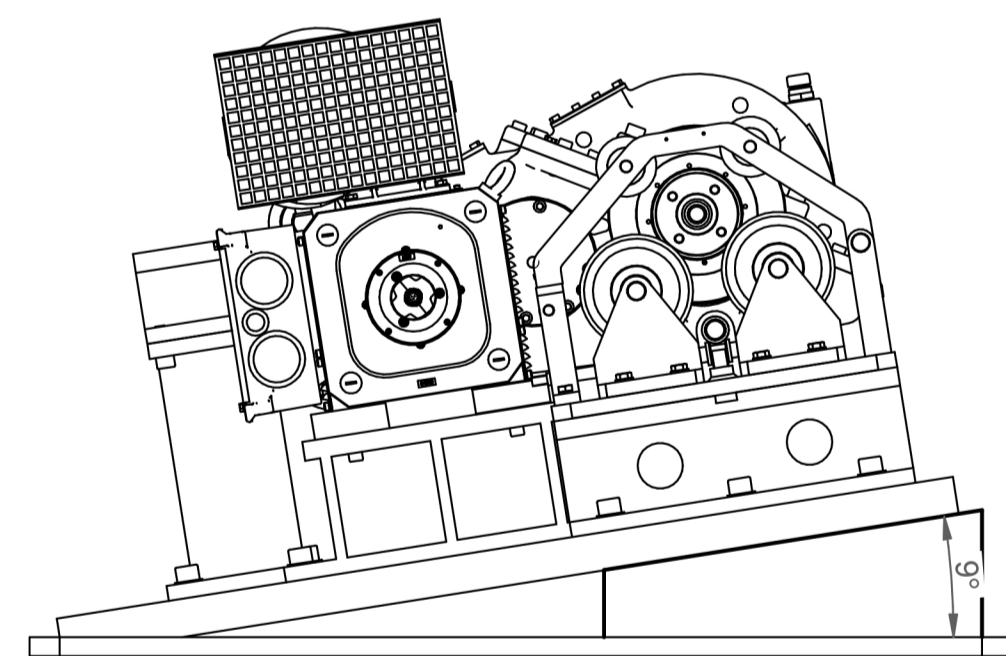
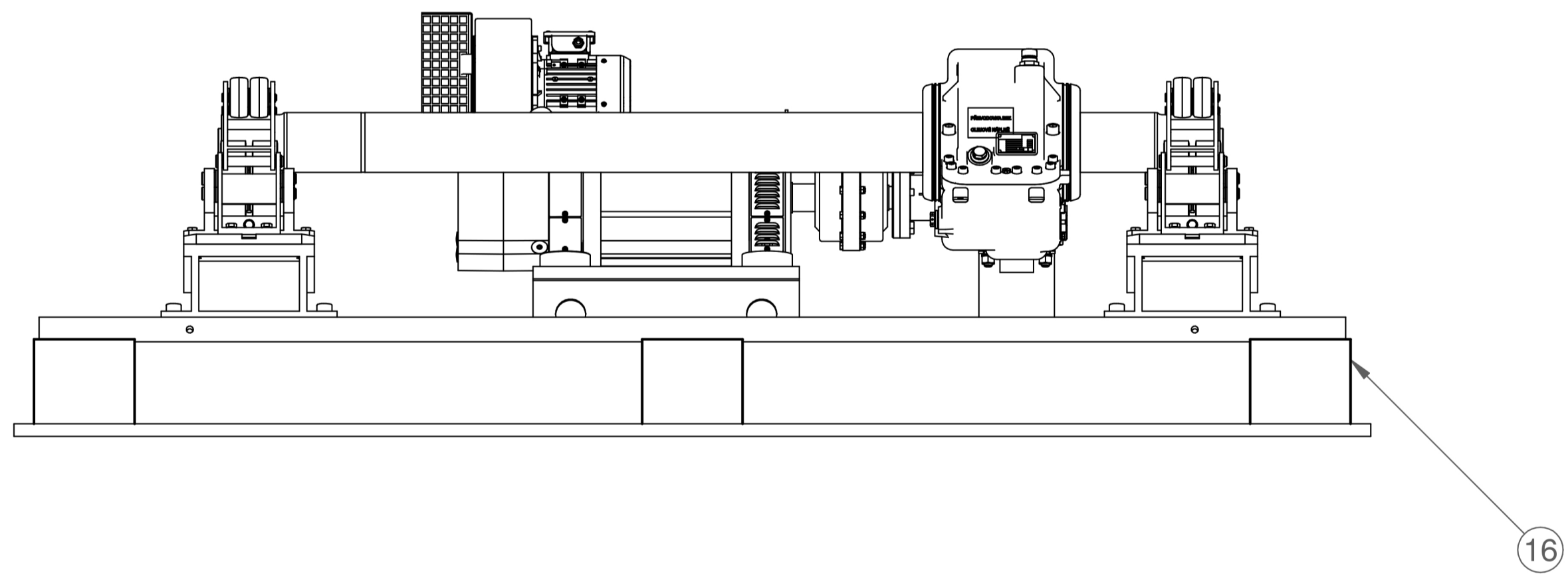
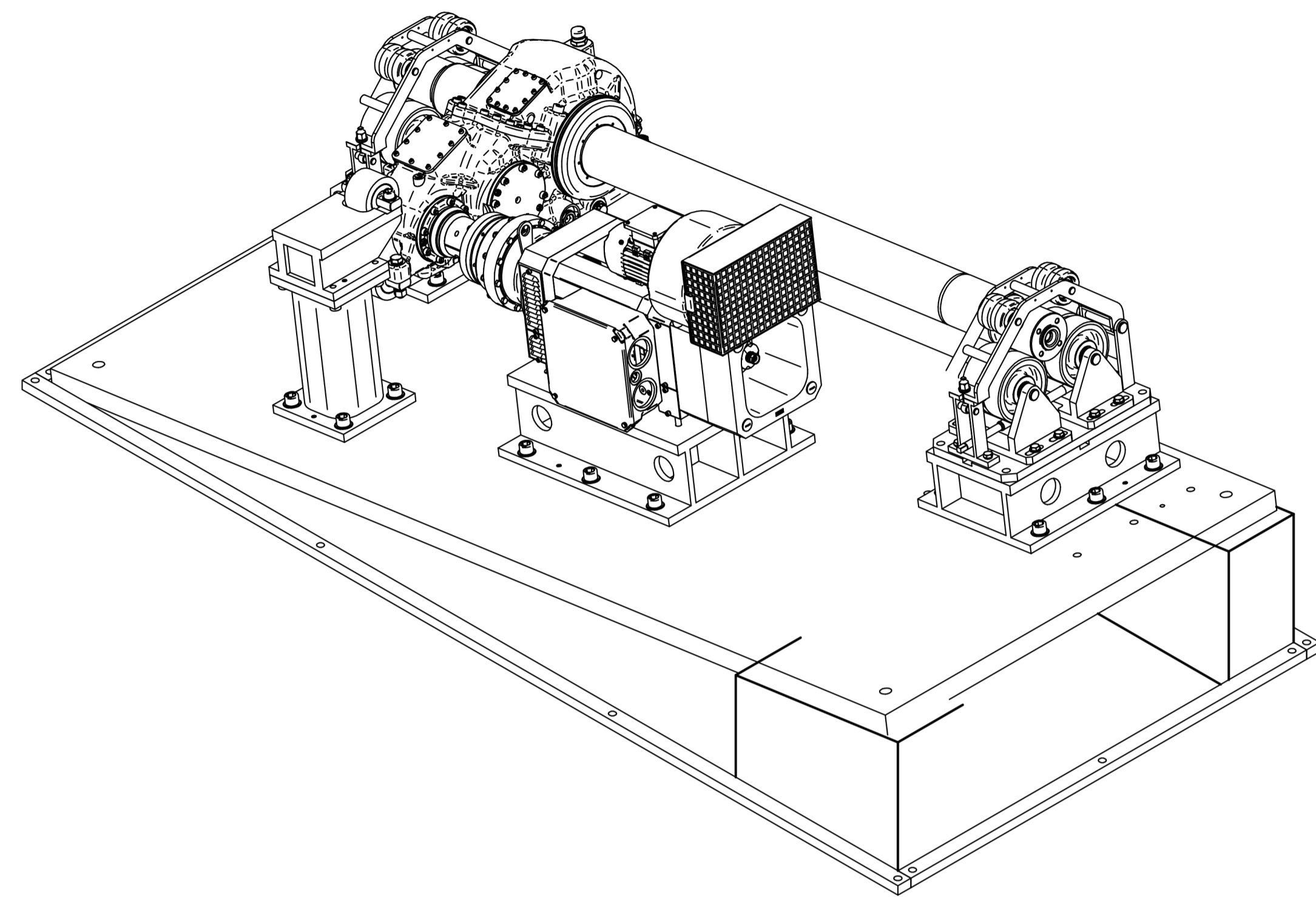
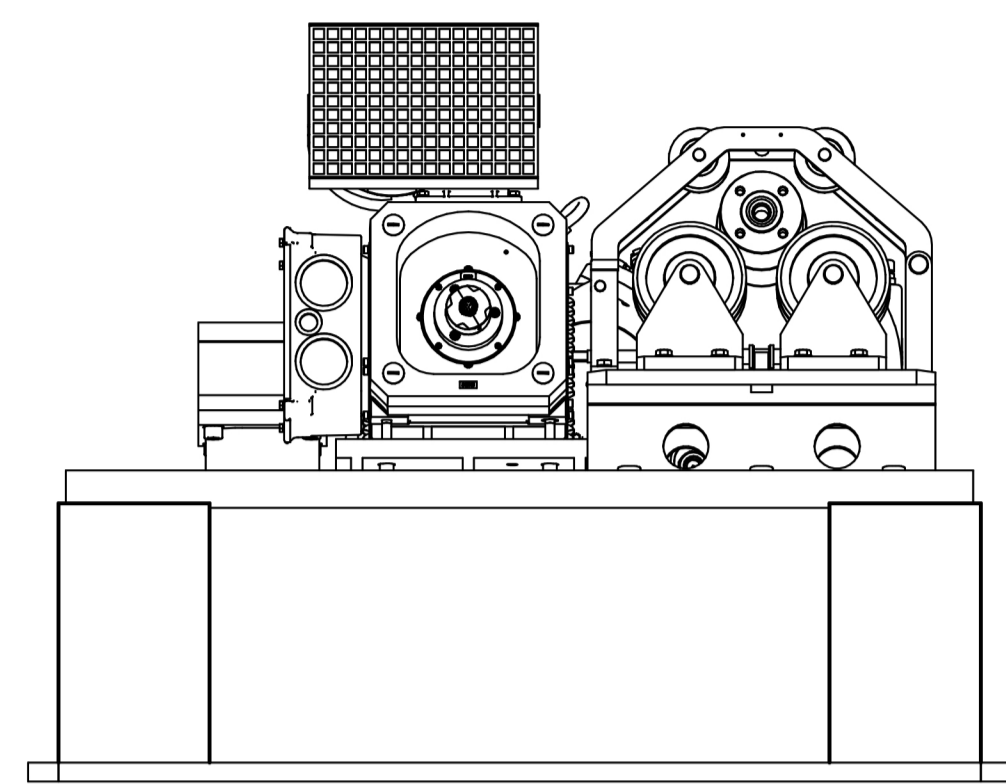
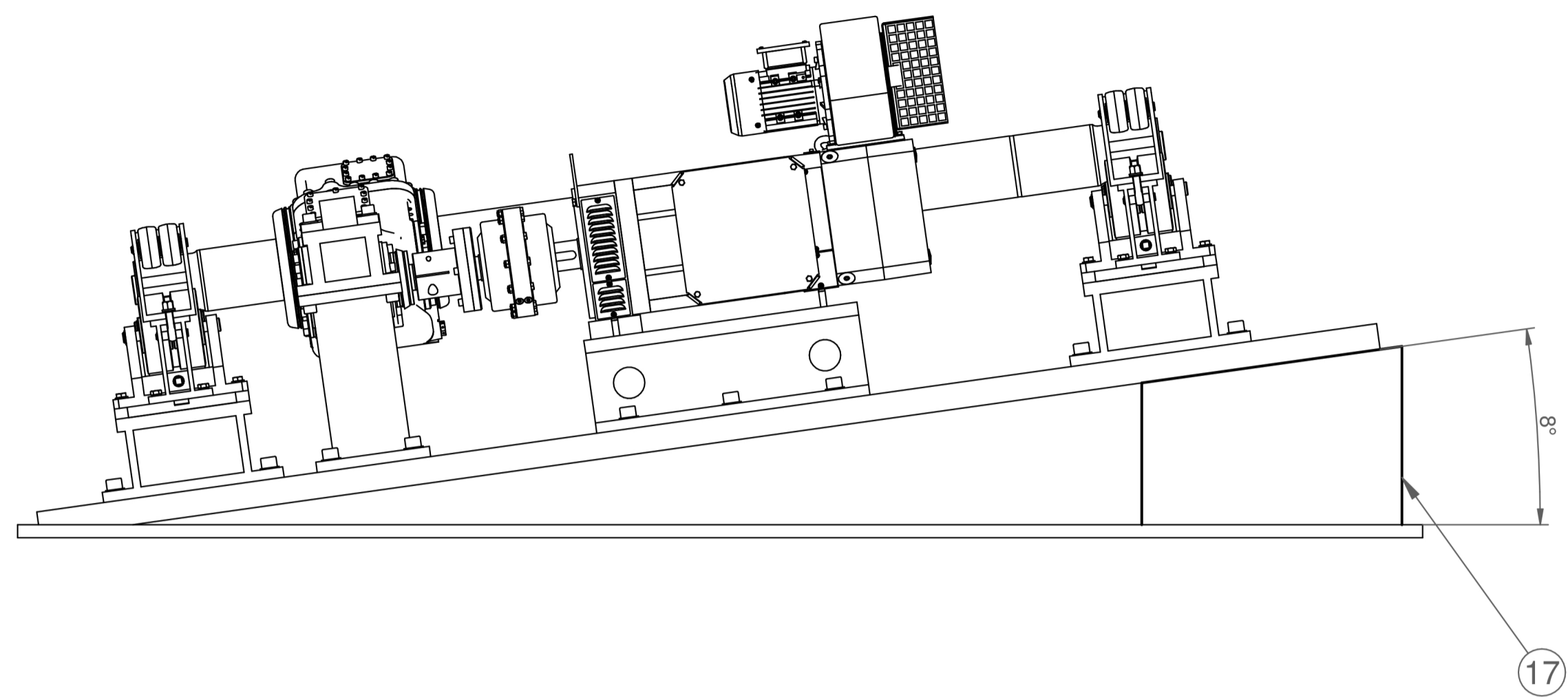

		Dimension / Rozměr:		Material / Materiál:		Weight / Hmotnost:		Weight code / Hmotnost kód:	
Projection method / Zobrazení:		Scale / Měřítko:		Drawn / Nalímal:		Type / Typ:		Weight 1941,1 kg	
ISO 15024:2008		1:10		mcvikyr		TRAM		Quality standard / Standard kvality:	
Unspecified tolerances / Neupřesněné tolerance:		Checked / Kontroloval:		Approved / Schválil:		Date / Datum:		Remarks / Poznámky:	
ISO 2768-mS		jspulak		06.02.2020		06.02.2020		#C	
Formed tolerances / Utvářené tolerance:		Title / Název:		Drawing Number / Číslo kresby:		Revision / Revize:		Sheet / List:	
ISO 15024:2008		PRIPRAVEK ZABIHACI		V-5123		#C		2/3	
ISO 1302		Form / Formát:		A1		www.wikov.com			
ISO 15024:2008									