

H-H (1:2)

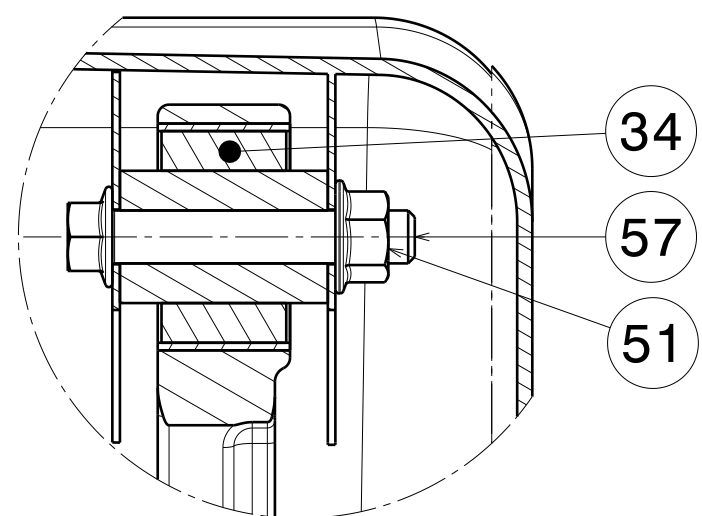

F-F (1:2)

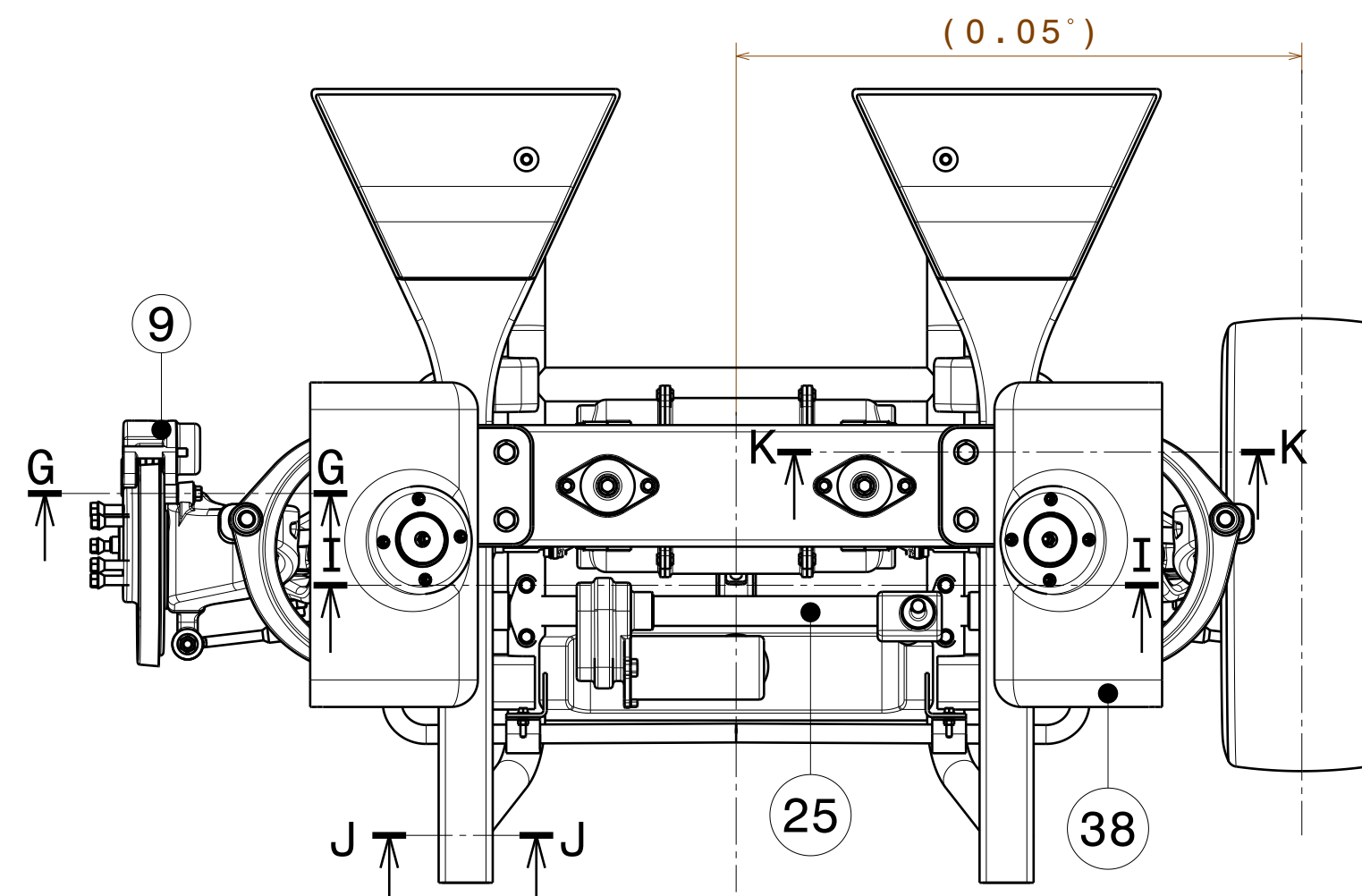

- NOTES:
1. MEASURED UNDER GROSS VEHICLE WEIGHT
2. TOLERANCES ARE
TOE ANGLE $0,05^{\circ} \pm 0,1^{\circ}$
CAMBER ANGLE $-0,5^{\circ} \pm 0,5^{\circ}$
CASTER ANGLE $5,46^{\circ} \pm 0,5^{\circ}$
KINGPIN INCLINATION ANGLE $7,09^{\circ} \pm 0,5^{\circ}$

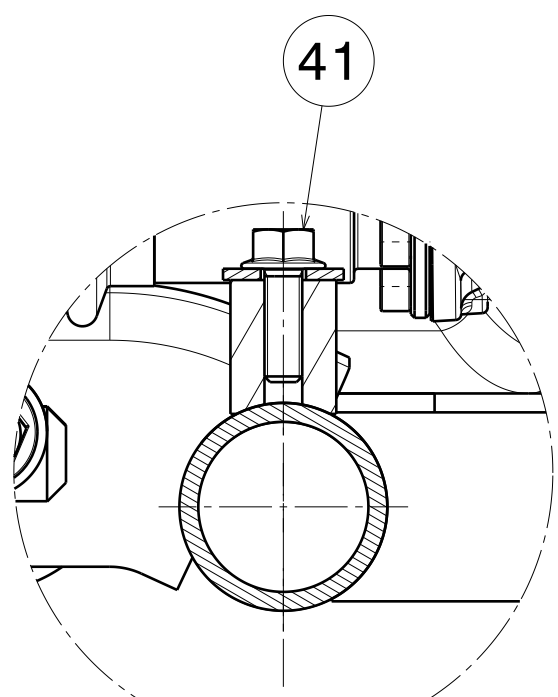

I-I (1:2)

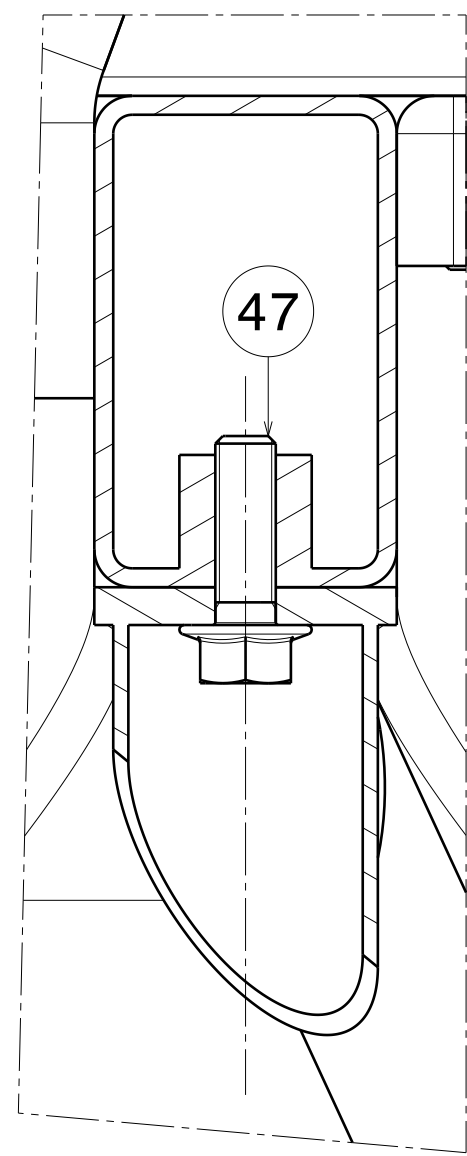

J-J (1:2)

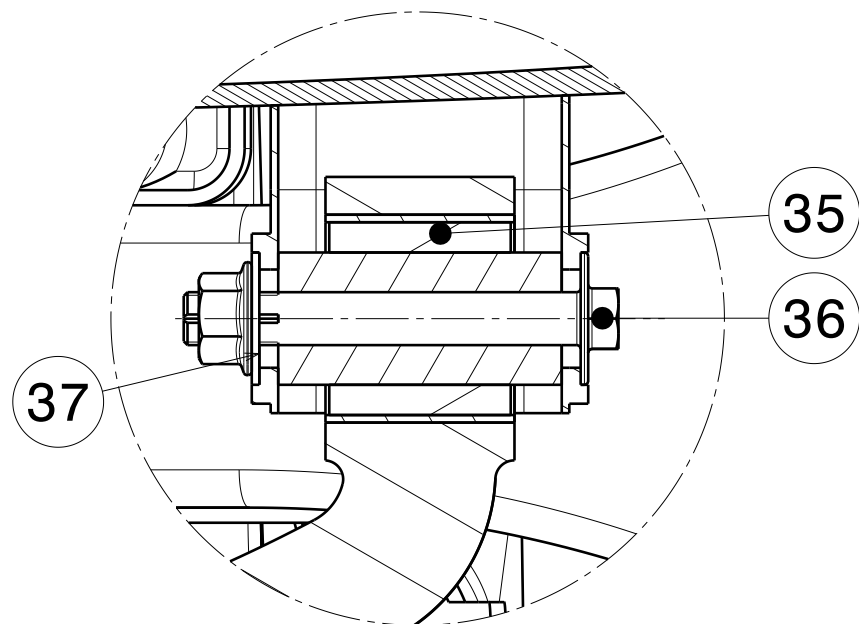

E-E (1:2)

		CVUT Fakulta strojni		
		DRAWING TITLE		
		FRONT AXLE		
DRAWN BY ONDICA	DATE 4/12/2019	SIZE A2	DRAWING NUMBER 00000 MAIN ASSEMBLY	REV X
CHECKED BY XXX	DATE xxx	SCALE 1:10	WEIGHT(kg)	SHEET 1/2
DESIGNED BY XXX	DATE xxx			