

Příloha 3

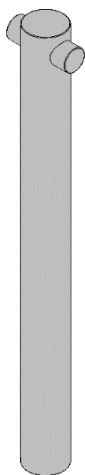

Obr. 1 Sestava hřídelí

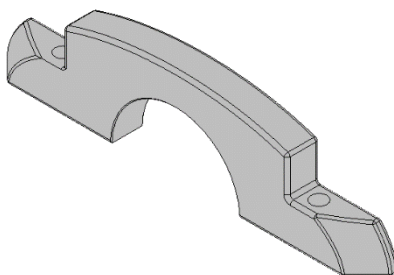

Obr. 2 Horní příruba

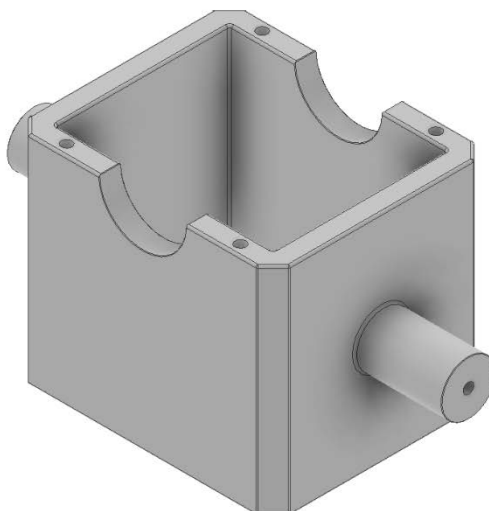

Obr. 3 Hlavní rám

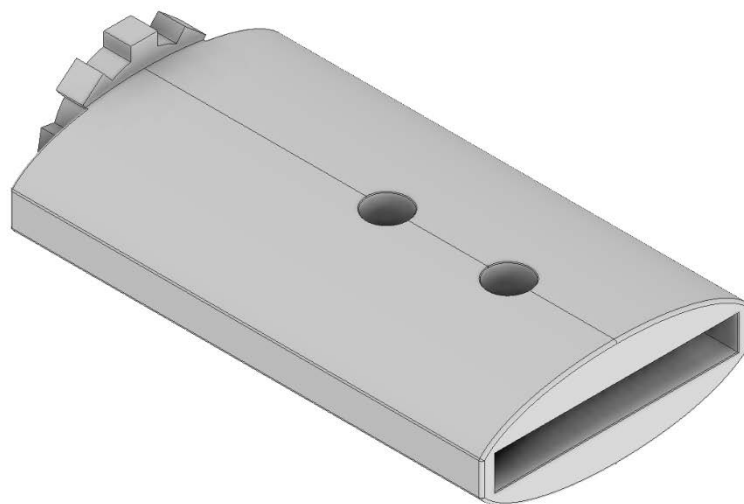

Obr. 4 Pouzdro listu rotoru

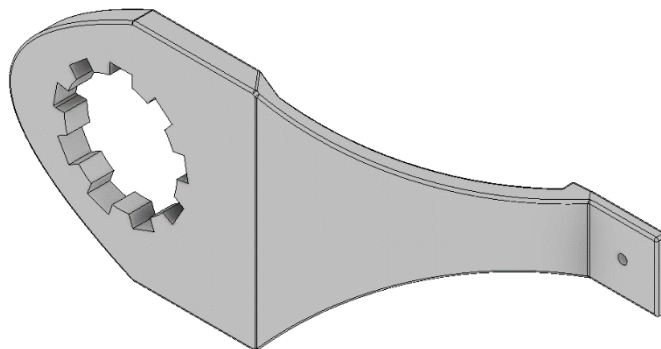

Obr. 5 Páka pouzdra listu rotoru



Obr. 6 Táhlo

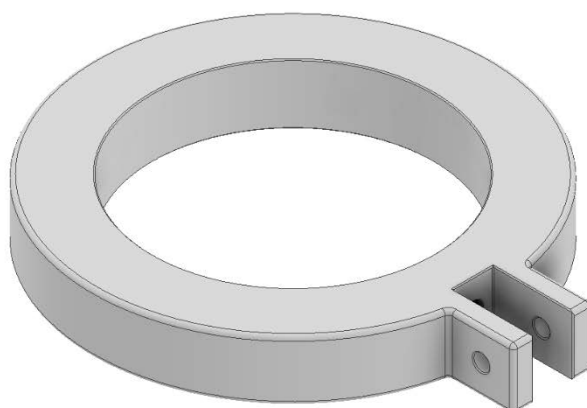

Obr. 7 Disk stabilizátoru

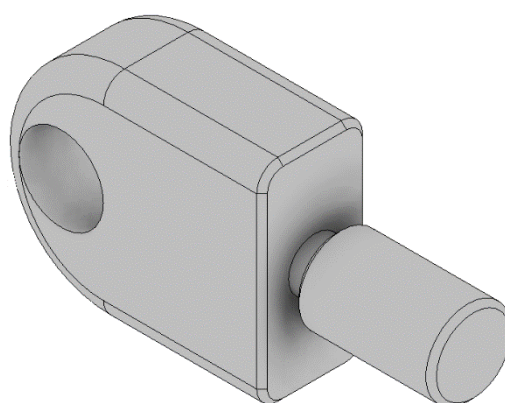

Obr. 8 Otočný závěs

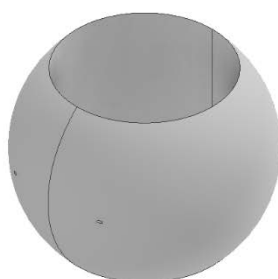

Obr. 9 Spojka hřídele s řídicí deskou

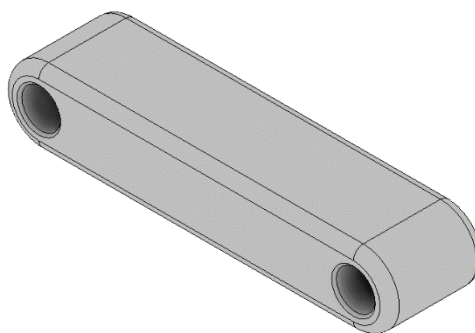

Obr. 10 Rameno stabilizátoru

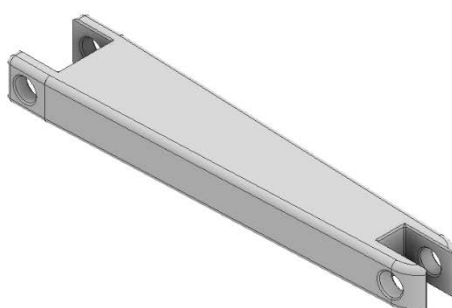

Obr. 11 Spojka stabilizátoru a řídicí desky



Obr. 12 Spodní řídicí deska k spojení táhel od řízení pilota

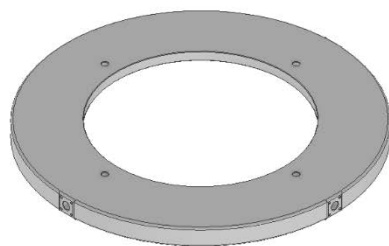

Obr. 13 Horní díl řídicí desky k spojení táhel k listům rotoru

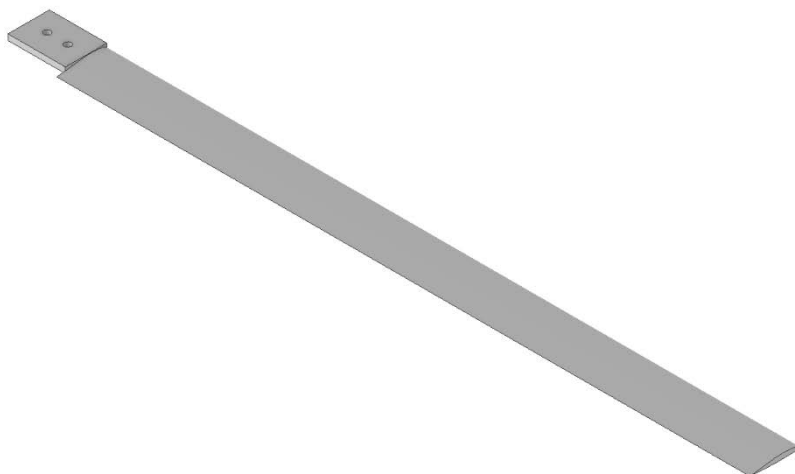

Obr. 14 List nosného rotoru

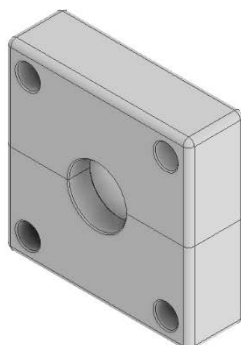

Obr. 15 Distanční deska