

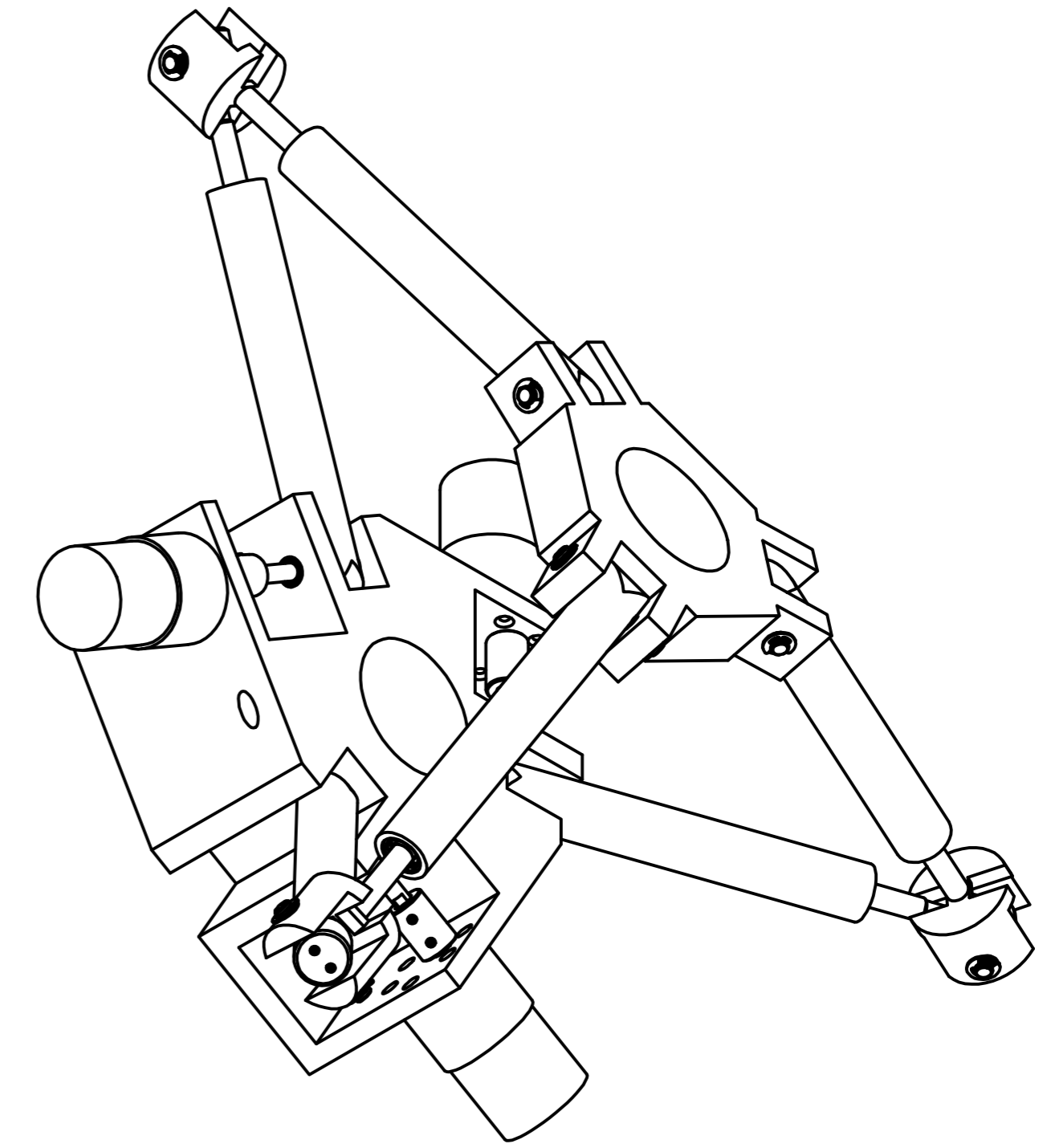

KUSOVNÍK			
POLOŽKA	KS	ČÍSLO SOUČÁSTI	POPIS
1	1	50076_J_01_Zakladni_plosina_J1	
2	18	W 627/6-2Z	BB1_001_101-Deep groove ball bearings
4	3	50076_J_03_Spojka_J1	
5	3	50076_J_04_Hridel_J1	
7	6	CNS 169 - 3 x 3 x 10	Těsné pero
8	12	619/6	BB1_001_101-Deep groove ball bearings
10	6	50076_J_10_Distančni_trubka_J1	
11	18	CNS 9076 - 5	Pojistná podložka
12	6	CNS 9074 - 15 x 1	Pružný pojistný kroužek
14	1	50076_J_02_Horni_plosina_J1	
15	3	50076_J_09_Hridel_J3	
16	3	50076_J_08_Hridel_J2	
17	6	DIN EN ISO 4028 - M3 x 8	Stavěcí šrouby s vnitřním šestihranem s čípkem
19	6	DIN EN ISO 4028 - M3 x 5	Stavěcí šrouby s vnitřním šestihranem s čípkem
20	3	50076_J_06_Spojka_J1	
21	6	50076_J_05_Rameno_J1	
22	3	50076_J_07_Spojka_J2	
23	3	50076_DFROBOT_FIT0185	

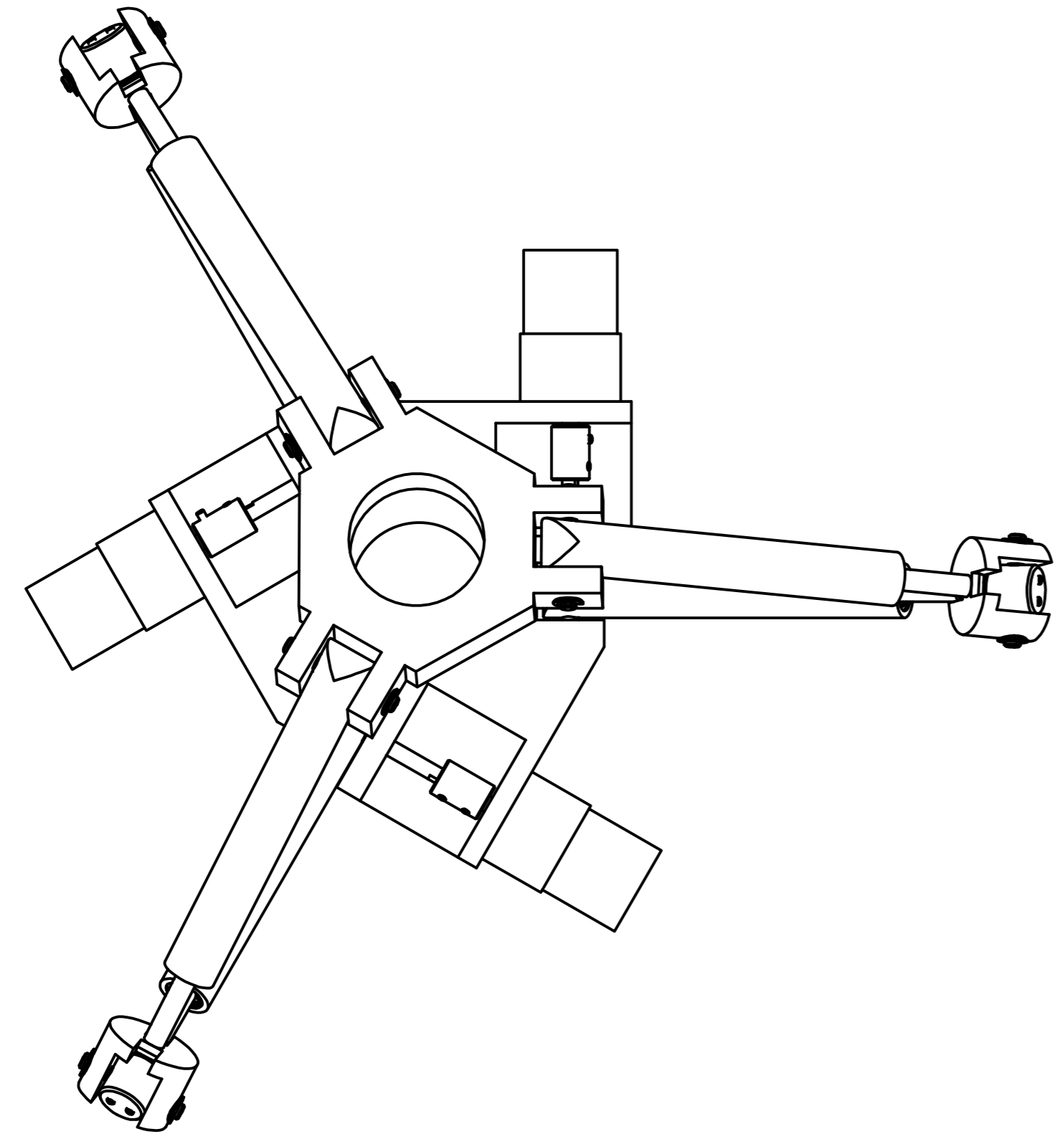

MĚŘITKO 1:2	MATERIÁL POLOTOVAR	PŘESNOST ISO 2768 - mK PROMÍTÁNÍ	VYPRACOVAL JANOUCHEK		
INDEX	ZMĚNY	DATUM	JMÉNO		DATUM 7. 2. 2019
1				CANFIELD JOINT J1	
2					
3					
4					
5					
6					
7					
				TYP ČÍSLO VÝKRESU 50076-J-00-01	LIST 1 A2