

DETAIL B
SCALE 2 : 1

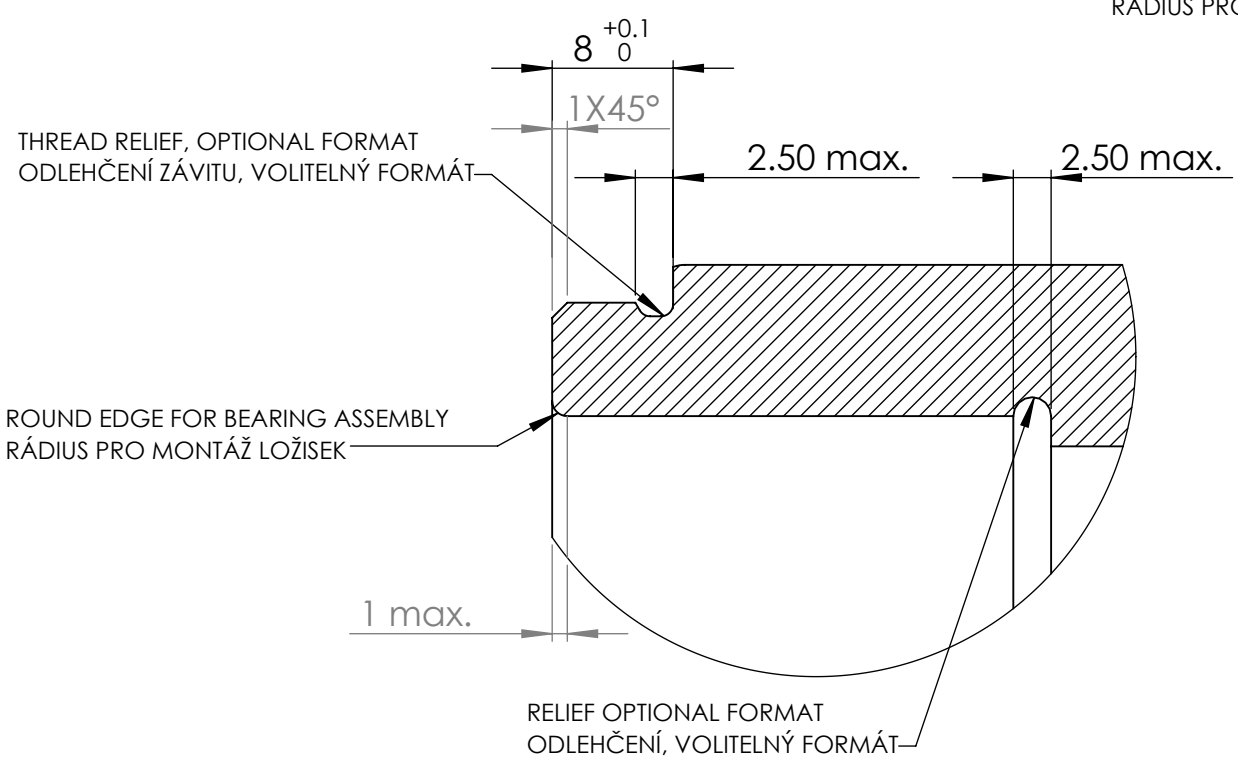

DETAIL C
SCALE 1 : 1

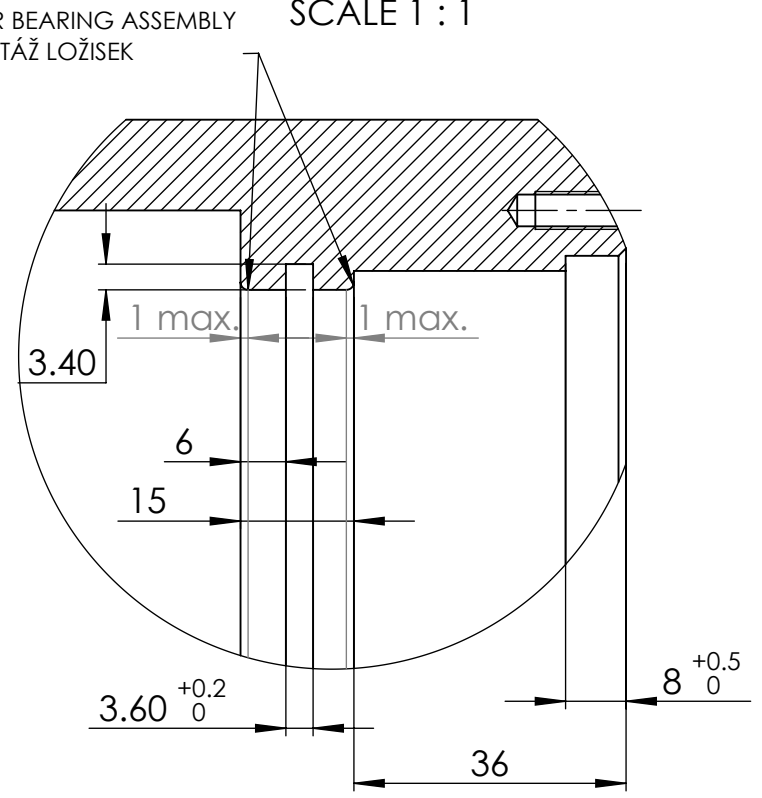

NEKÓTOVANÉ HRANY SRAZIT MAX 0,3x45°
NEKÓTOVANÉ VNITŘNÍ HRANY R-MAX 0,5

BREAK SHARP EDGES TO MAX 0,2x45°
UNDIMENSIONED INNER EDGES R-MAX 0,5

MATERIÁL 14 220.4
POLOTOVAR ZUŠLECHTIT NA 850 MPa
PO BROUŠENÍ ČERNĚNO

MATERIAL 14 220.4
HEAT TREAT TO 850 MPa
BLACKENING AFTER GRINDING
Kontaktní osoba v ČR - Ing. Tiefenbach +420 776 706 249

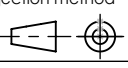
 Tel: +45 63 22 00 19 www.viking-cnc.dk	Weight	6.26 kg	Projection method	
	Format	A3	Created	Philip Haas
	Scale	1:2	Page	1/1
	Date	18.09.2018	Model Rev.	
	State	Approved		A
	Drawing No.		Dwg. Rev.	
Process	Machining	Mat.	Hardened Steel	B-716
				A

Spindle Pipe