

K42L

TRUCK-MOUNTED CONCRETE BOOM PUMP

Placing boom	B5RZ 42/38
Pumping unit	HP1808ECX HP1608EC HP1606H
Driven by	PTO or gearbox
Chassis	4 axles



Dimensions

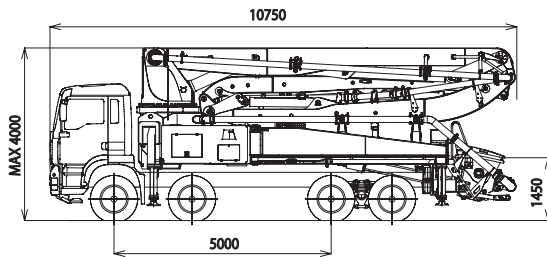

Dimensions varying according to truck assembly

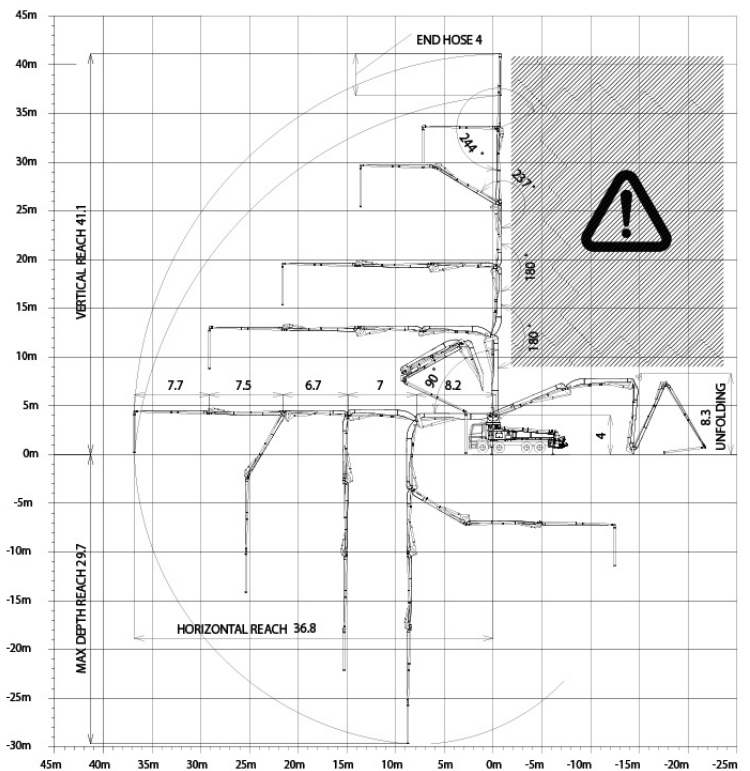
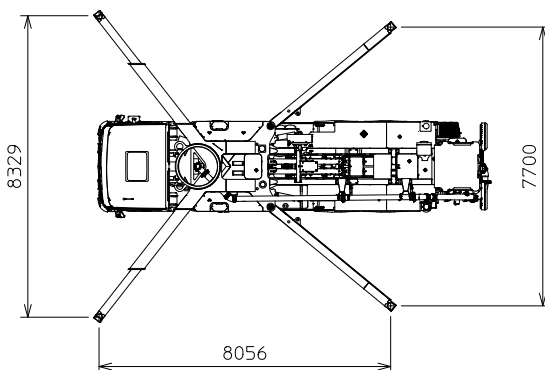

K42L

Standard equipment

- Advantageous assembling on standard 4 axles chassis
- Self-supporting frame, torsion free, FEM designed
- Placing boom B5RZ 42/37, 5 sections, "RZ" folding system
- Fully hydraulic outrigger controls on both sides of the truck
- Front "X" style diagonal outriggers with double telescopic opening and swing-out rear outriggers for a quick and easy set-up also in narrow areas
- "Load Sensing" proportional boom control for pumping unit HP-C
- Concrete flow rate regulator
- Safety device on opening inspection hatch
- Two pumping units with closed loop (HP1608EC or HP1808ECX) or one with open loop (HP1606H)
- Project conforms to Directive Machinery 2006/42/CE
- 2 Proportional radio control Hetronic 3 joystick. 20 mt cable
- Double thickness concrete pipes, in high resistant steel and insert carbide chrome - CIFA Long Life Pipes
- Emergency control pad for pumping unit HP-C
- Remote controlled electric vibrator placed on the concrete hopper grid
- Centralized lubrication system for pumping unit
- Automatic oil lubrication system for pumping pistons
- Additional manual lubrication system for pumping pistons
- Hard plastic outrigger support plates with relative housing
- Rear light on hopper
- Level readers for stabilization control
- Accessories for cleaning and pipes washing
- Fiber glass hopper covering

Control System with pumping unit HP1608EC or HP1808ECX

- Smartronic Silver:
 - intergrated color LCD
 - counters
 - pumping unit management
 - diagnostic
 - capsense rear panel

Control System with pumping unit HP1606H

- Easytronic Silver:
 - intergrated LCD
 - counters
 - pumping unit management
 - diagnostic

Main options

- Smartronic Gold (Smartronic Silver + ASC Advanced Stability Control) *(Available only with closed loop)*
- Easytronic Gold (Easytronic Silver + LSC Light Stability Control) *(Available only with open loop)*
- High pressure water pump 28l / 120 bar
- Centralized lubrication system for placing boom
- Separated emergency engine kit for independent control of the concrete pumping unit, boom and water pump
- Double thickness boom straight pipes, in high resistant steel and insert carbide chrome - CIFA LLT Long Life Top
- Proportional radio control with display

TRUCK-MOUNTED CONCRETE BOOM PUMP

Placing boom	B5RZ 42/38
Pumping unit	HP1808ECX HP1608EC HP1606H
Driven by	PTO or gearbox
Chassis	4 axles

Pumping unit technical data

Model		HP1808ECX	HP1608EC	HP1606H
Max. theoretical output	<i>m³/h</i>	180	160	160
Max. pressure on concrete	<i>bar</i>	83	80	53
Conc. cylinders (diam. x stroke)	<i>mm</i>	260x2100	230x2100	230x2100
Concrete hopper capacity	<i>l</i>	600	550	550
Hydraulic circuit		closed	closed	open

Placing boom technical data

Model		B5RZ 42/37
Pipeline diameter	<i>mm</i>	125
Max. vertical reach	<i>m</i>	41,1
Max. horizontal distance (from center of slewing axis)	<i>m</i>	36,8
Min. unfolding height	<i>m</i>	8,3
Section numbers		5
1st section opening angle		90°
2nd section opening angle		180°
3rd section opening angle		180°
4th section opening angle		237°
5th section opening angle		244°
Rotating angle		+/-270°
End hose length	<i>m</i>	4

Technical data and characteristics subject to modifications without notice