

A-A

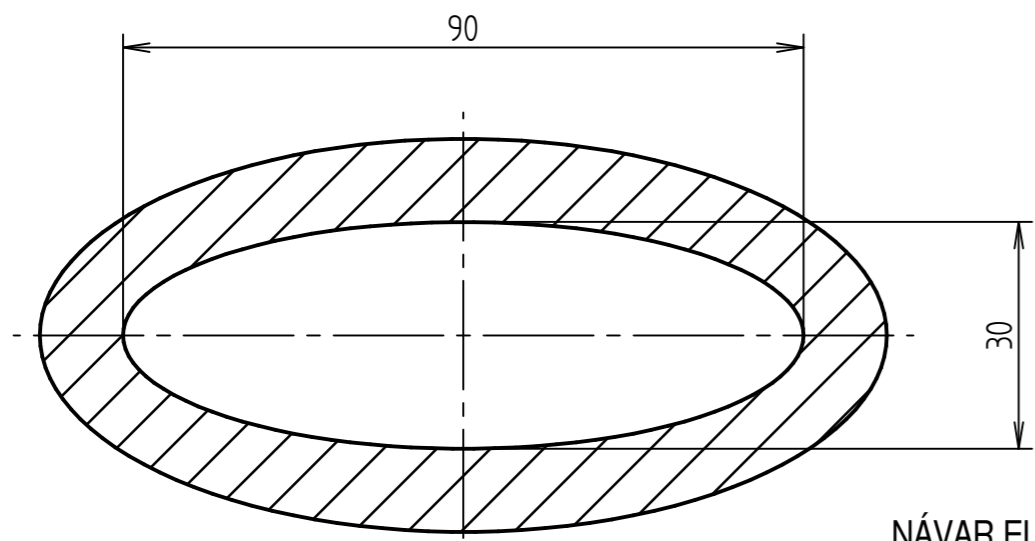

B (1:1)

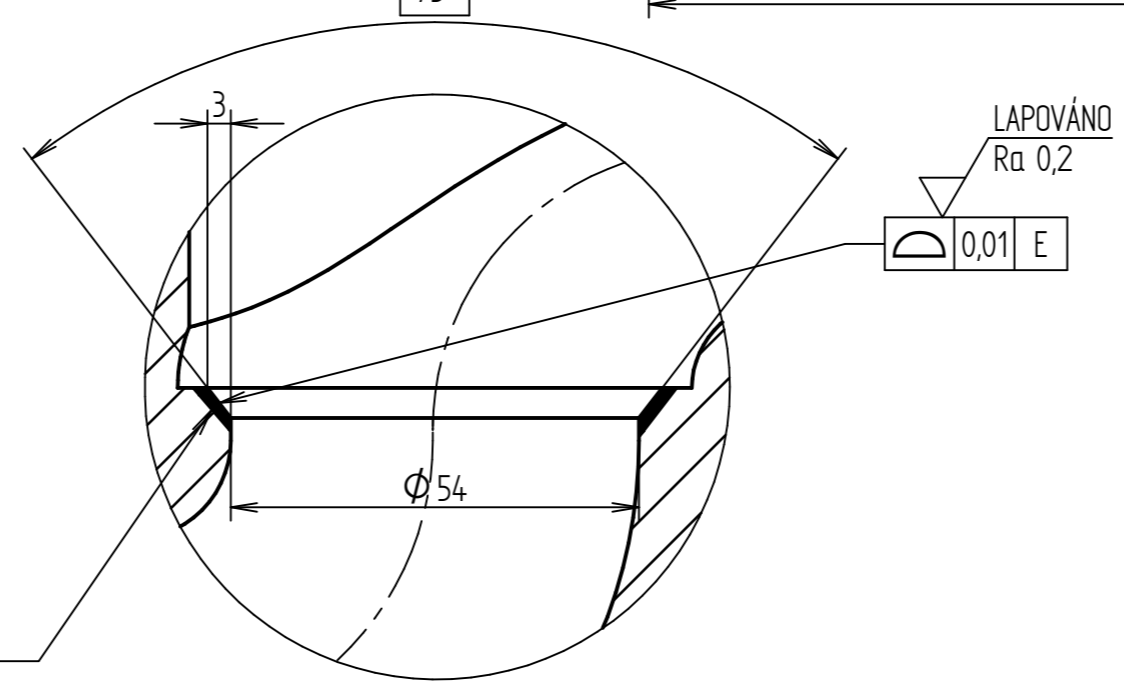

NÁVHR ELEKTRODOU E 638.77
ČSN 05 5174

VŠEOBECNÉ TOLERANCE ISO 8062-3 - DCTG 13 - RMA 6 (RMAG H)

MATERIAL: 42 2939.2		RAOVÁNÍ Ra 6,3 (Ra 1,6 Ra 0,8 LAPOVANO Ra 0,2)			
POLOTOVAR: ODLITEK		TOLEROVANI DLE ISO 8015			
PRESNOST ISO 2768 - mK		VSEOB. TOL. ISO 8062 - DCTG 13 - RMA 6 (RMAG H)			
Autor	Datum	PREZK.	Podpis	Datum	HMOTNOST
NAVRHL Ondřej Havlíček	11. 5. 2018	SCHVALIL Ondřej Havlíček		11. 5. 2018	0,000 kg
SESTAVA			MÉRITKO		
KUSOVNIK			1:2(1:1)		
NÁZEV			TYP.		
ČÍSLO VÝKRESU			TYP.		
TĚLESO			BP-2018-02		

SOLID EDGE ACADEMIC COPY