



**CZECH TECHNICAL UNIVERSITY IN PRAGUE**

---

**FACULTY OF BIOMEDICAL ENGINEERING**

**Department of Biomedical Technology**

**The comparison of ventilation  
parameters of anesthesia ventilators and  
ICU ventilators**

Bachelor's thesis

Study program: Biomedical and Clinical Technology

Study branch: Biomedical Technician

Student: Aneta Kloudová

Supervisor: prof. Ing. Karel Roubík, Ph.D

---

**Kladno 2018**

## Bachelor thesis assignment

Student: **Aneta Kloudová**

Study branch: Biomedical Technician

Title: **The comparison of ventilation parameters of anesthesia ventilators and ICU ventilators**

Title in Czech: Porovnání ventilačních parametrů ventilátorů používaných v anesteziologické a intenzivní péči

### Instructions for processing:

Design an experimental protocol for testing the accuracy of ventilation parameters on anesthesia ventilators and intensive care unit ventilators. Conduct the testing of the ventilators under various ventilation modes and lung model settings. Based on the measured data, assess how precisely the tested ventilators reproduce the required preset values.

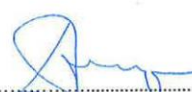
### References:

- [1] Juliana C. Ferreira, Daniel W. Chipman, Robert M. Kacmarek, Trigger performance of mid-level ICU mechanical ventilators during assisted ventilation: a bench study, *Intensive Care Medicine*, Volume 34, Issue 9, April 2008, pp. 1669-1675.
- [2] Thomas C Blakeman MSc RRT, Richard D Branson MSc RRT FAARC, Evaluation of 4 New Generation Portable Ventilators, *Respiratory Care*, Volume 58, Issue 2, February 2013, pp. 264-272.
- [3] Michihisa Teradoa, Shingo Ichibab, Osamu Naganoa, Yoshihito Ujikea, Evaluation of Pressure Support Ventilation with Seven Different Ventilators Using Active Servo Lung 5000, *Acta Med. Okayama*, Volume 62, Issue 2, 2008, pp. 127-133.

Validity of assignment until date: 11. 9. 2018

Supervisor of bachelor thesis: prof. Ing. Karel Roubík, Ph.D.

  
.....  
Head of Department

  
.....  
Dean

In Kladno, 19. 02. 2018

## Z a d á n í   b a k a l á ř s k é   p r á c e

Student: **Aneta Kloudová**  
Obor: Biomedicínský technik  
Téma: **Porovnání ventilačních parametrů ventilátorů používaných v anesteziologické a intenzivní péči**  
Téma anglicky: The comparison of ventilation parameters of anesthesia ventilators and ICU ventilators

### Z á s a d y   p r o   v y p r a c o v á n í :


Navrhňte protokol experimentu pro ověření schopnosti dodržení nastavovaných ventilačních parametrů u anesteziologických ventilátorů a ventilátorů používaných v intenzivní péči. Měření proveďte při různých ventilačních režimech a s různými nastaveními modelu plic. Z naměřených dat vyhodnoťte, u kterého z uvedených typů ventilátorů se naměřené hodnoty lépe shodují s hodnotami nastavenými.

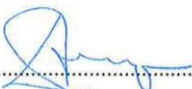
### Seznam odborné literatury:

- [1] Juliana C. Ferreira, Daniel W. Chipman, Robert M. Kacmarek, Trigger performance of mid-level ICU mechanical ventilators during assisted ventilation: a bench study, Intensive Care Medicine, ročník 34, číslo 9, 2008, Duben, 1669-1675 s.  
[2] Thomas C Blakeman MSc RRT, Richard D Branson MSc RRT FAARC, Evaluation of 4 New Generation Portable Ventilators, Respiratory Care, ročník 58, číslo 2, 2013, Únor, 264-272 s.  
[3] Michihisa Teradoa, Shingo Ichibab, Osamu Naganoa, Yoshihito Ujikea, Evaluation of Pressure Support Ventilation with Seven Different Ventilators Using Active Servo Lung 5000, Acta Med. Okayama, ročník 62, číslo 2, 2008, 127-133 s.

Zadání platné do: 21.09.2018

Vedoucí: prof. Ing. Karel Roubík, Ph.D.

  
.....  
vedoucí katedry / pracoviště

  
.....  
děkan

V Kladně dne 19.02.2018

## **Declaration**

I hereby declare that I have completed this thesis with the topic “The comparison of ventilation parameters of anesthesia ventilators and ICU ventilators” independently and I have included a full list of used references.

I do not have a compelling reason against the use of the thesis within the meaning of Section 60 of the Act No 121/2000 Coll., on copyright, rights related to copyright and amending some laws (Copyright Act).

In Kladno, date .....

.....

Student's signature

## **ACKNOWLEDGEMENTS**

I would like to thank my counsellor Prof. Karel Roubík, Ph.D. for his support, advices, and for help in conducting the measurements.

## **ABSTRACT**

**The title of the Thesis:** The comparison of ventilation parameters of anesthesia ventilators and ICU (Intensive Care Unit) ventilators.

The main aim of the thesis was the comparison of ventilation support, PEEP level delivery and triggering performance between the group of intensive care and anesthesia ventilators. Three intensive care ventilators and three anesthesia ventilators were tested in synchronized ventilation modes connected to a lung model. The ventilation parameters were measured under various ventilator settings and various lung model settings. Significant differences were observed in the measured parameters between the anesthesia and ICU ventilators but also inside the individual groups of ventilators. The newest ICU ventilators showed the most accurate results and the fastest triggering response. The parameters of the newest anesthesia ventilators differed from the parameters obtained with the older generation of anesthesia machines, and their performance was closer to the performance of ICU ventilators.

### **Keywords**

Mechanical ventilator, intensive care unit, anesthesiology.

## **ABSTRAKT**

**Název práce:** Porovnání ventilačních parametrů ventilátorů používaných v anesteziologické a intenzivní péči.

Cílem práce bylo porovnání přesnosti dodávané ventilační podpory, hladiny PEEP a rychlosti odezvy ventilátoru na dechové úsilí modelu plic za použití synchronizovaných ventilačních režimů mezi anesteziologickými ventilátory a ventilátory používanými na jednotkách intenzivní péče. Měření proběhlo na třech intenzivistických a na třech anesteziologických ventilátorech, které byly připojeny k modelu plic. Ventilační parametry ventilátorů byly testovány při různých nastaveních modelu plic i ventilátoru. Měřené ventilační parametry se významně lišily mezi skupinou anesteziologických a intenzivistických ventilátorů, ale i v rámci obou skupin ventilátorů. Skupina nejnovějších intenzivistických ventilátorů vykazovala největší přesnost měřených parametrů a nejrychlejší synchronizaci s dechovým úsilí modelu plic. Parametry nejnovějších anesteziologických ventilátorů byly rozdílné od parametrů měřených na starších anesteziologických ventilátorech a přibližovali se parametrům ventilátorů používaných v intenzivní péči.

### **Klíčová slova**

Plicní ventilátor, plicní ventilace, jednotka intenzivní péče, anesteziologie.

## **Table of content**

<b>List of symbols and abbreviations .....</b>	<b>14</b>
<b>1 Introduction .....</b>	<b>15</b>
1.1 Current state .....	16
1.1.1 Conventional positive-pressure ventilation .....	16
1.1.2 ICU and anesthesia machine design .....	22
1.2 Aim of the thesis .....	27
<b>2 Materials and methods.....</b>	<b>29</b>
2.1 Ventilators tested.....	29
2.2 Test lung model and test lung model setting.....	29
2.3 Ventilator setting.....	30
2.4 Variables evaluated .....	32
2.5 Data collection and analysis.....	35
<b>3 Results .....</b>	<b>36</b>
3.1 Example of the normality test .....	36
3.2 Overall ventilation pressure, volume and PEEP delivery .....	37
3.3 Difference between the pressure and flow curves during the breath triggering.....	39
3.3.1 Pressure control ventilation .....	39
3.3.2 Volume support ventilation.....	41
3.4 Effects of different model and simulator settings on the triggering performance.....	43
3.4.1 Impact of various inspiratory peak pressure and tidal volume .....	43
3.4.2 Impact of various PEEP levels .....	44
3.4.3 Impact of various compliance and resistance of the model.....	46
3.4.4 Impact of respiratory rate .....	47
3.4.5 Impact of ventilation mode .....	48
3.5 Overall triggering performance of the ventilators.....	50
<b>4 Discussion.....</b>	<b>51</b>
<b>5 Conclusion.....</b>	<b>58</b>
<b>6 References .....</b>	<b>59</b>
<b>Appendix A: The protocol of measurement for PCV mode .....</b>	<b>63</b>
<b>Appendix B: The protocol of measurement for VCV mode.....</b>	<b>65</b>
<b>Appendix C: CD.....</b>	<b>67</b>



# List of symbols and abbreviations

## The list of symbols

Symbol	Unit	Meaning
$C$	mL/cm H <sub>2</sub> O	Compliance
$FiO_2$	%	Fraction of Inspired Oxygen
$PEEP$	cm H <sub>2</sub> O	Positive End-Expiratory Pressure
$P_{insp}$	cm H <sub>2</sub> O	Maximum Inspiratory Pressure
$P_{trig}$	cm H <sub>2</sub> O	Maximum Pressure Drop during Triggering
$R$	cm H <sub>2</sub> O·s/L	Resistance
$T_{90}$	ms	Time to achieve 90 % of maximum $P_{insp}$
$Time\ to\ P_{min}$	ms	Time to $P_{trig}$
$T_{trig}$	ms	Time to trigger
$V_T$	mL	Tidal Volume

## The list of abbreviations

Abbreviation	Meaning
ACV	Assist Control Ventilation
ARDS	Acute Respiratory Distress Syndrome
BIPAP	Biphasic Positive Airway Pressure
BPM	Breaths per Minute
CMV	Continuous Mandatory Ventilation
COPD	Chronical Obstructive Pulmonary Disease
CPAP	Continuous Positive Airway Pressure
CT	Computer Tomography
EET	Endotracheal
ICU	Intensive Care Unit
IMV	Intermittent Mandatory Ventilation
PCV	Pressure Control Ventilation
PSV	Pressure Support Ventilation
SIMV	Synchronized Intermittent Mandatory Ventilation
VILI	Ventilator-Induced Lung Injury

# 1 Introduction

Mechanical ventilators find application in many clinical branches reaching from the Intensive Care Unit (ICU), operating rooms, radiology department, hospital and emergency transport, home environments to the military field of use. Mechanical ventilation is a process that fully or partially substitutes patient's ability of gas exchange between the respiratory system and external environment. Mechanical ventilators find their use mainly at the intensive care department, known as ICU ventilators, intended for a long-term use, or in the operating rooms, for ventilating anesthetized patients during surgery, referring to anesthesia ventilators [1, 2, 3].

The main function of the anesthesia machine is following: oxygen and defined gas mixture delivery to the patient's breathing system, enabling ventilation and prevention from injury risk to the surgical patient. The health state of the patients undergoing anesthesia with anesthesia machines varies, unlike the ICU ventilators, which serve patients with respiratory failure [5, 6].

ICU ventilators are used with patients suffering from respiratory failures which is defined as a state when the respiratory system is unable to perform basic gas exchange. Unstable metabolic and blood gas levels or excessive work of breathing are one of the symptoms for its application. Patients with acute respiratory distress symptom (ARDS) or chronic obstructive pulmonary disease (COPD) are examples of those requiring ventilation support at the intensive care unit. ARDS occurs as a consequence of lung inflammation or injury and results in low oxygenation due to liquid retention in alveoli that disables proper lung distention. This aspect increases the dead space volume and decreases lung compliance. COPD is characterized by a chronic air flow limitation, often with higher compliance and resistance. It is represented by a group of pulmonary diseases: the most typical ones are emphysema (damage to the alveoli sacks), asthma, or chronic bronchitis (long span airway inflammation) [3, 6, 7, 8, 9].

As described, ICU ventilators have to meet the demands of all kinds of critically ill patients, which means instantaneously adjusting to the changeable compliance and resistance of the patient's respiratory system in order to deliver the desired ventilation support. Conversely, anesthesia ventilators are mainly used with fully sedated patients that are typically not suffering from any respiratory insufficiency. Such machines use also different technical adjuncts and compartments in the ventilation system. Moreover, ICU ventilators are designed for a long-span use unlike their counterparts that are required only during the duration of surgery. In general, the ICU ventilators are constructed with smaller and more simple breathing circuit, and they are considered to be more precise. Despite the abovementioned disparities, the ventilator manufacturers offer common ventilation modes and settings for both types. Anesthesia machines have recently gone

through great technical development in order to flatten these drawbacks. Therefore, their performance should reach comparable standards and the anesthesia machine should theoretically provide critically ill patients needing a surgery with the same comfort as ICU ventilators [1, 2, 3, 4]

## **1.1 Current state**

If the patient requires ventilation support from a mechanical ventilator, there are numerous ventilation techniques, modes, and settings that the medical staff can opt for. The proper setting is selected according to the individual needs of the patient based on the lung pathology and mechanics, the ability of spontaneous breathing, hemodynamics and oxygenation. The gas flow during mechanical ventilation is ensured by pressure difference between two places. This can be achieved by applying a positive airway pressure into the breathing system or by creating a negative pressure in the pleural space. This defines the basic principles of a mechanical ventilation. The negative-pressure ventilation is considered as a historical procedure and modern ventilation machines are principally positive-pressure based. Another division could be made according to the set respiratory rate and tidal volumes, thus describing conventional and non-conventional type of ventilation [9, 10].

### **1.1.1 Conventional positive-pressure ventilation**

The following section is focusing at conventional positive-pressure ventilation, as it was used as a method for conducting the experimental part of the thesis.

#### **MECHANISM OF POSITIVE PRESSURE VENTILATION**

The breath delivery by the ventilator is defined by 4 phases during each ventilatory cycle: (1) trigger phase (breath initiation), (2) flow delivery, (3) cycle phase (breath termination) and (4) expiratory phase [11, 12, 13].

1. Breath can be triggered by [11, 12, 13]:

- Time trigger—the start of the breath is initiated by set timing mechanism without detecting the patient's effort. Such modes are known as controlled ventilation and they are utilized for patients without a spontaneous breathing ability.
  
- Pressure trigger—the ventilator reacts to the patient's inspiratory effort and senses a drop in the airway pressure. When the pressure in the breathing circle drops below the defined pressure trigger value, the ventilator assists patient's breath or enables inspiratory flow.
  
- Flow trigger—when the patient initiates inspiration, the flow in the circle drops. After exceeding the set flow threshold, the ventilator delivers an assisted breath.

2. The primary control variables for gas flow are [11, 12, 13]:
  - Pressure control (pressure-controlled ventilation)—the ventilator reaches fixed inspiratory pressure by alternating gas flow. The tidal volume differs according to variable compliance and resistance.
  - Volume control (volume-controlled ventilation)—the ventilator delivers tidal volume by using a fixed flow. The airway pressure during volume control ventilation varies in response to changes in compliance and resistance.
3. Cycling criteria is a mechanism responsible for the termination of the inspiratory phase and starting the expiration. Breaths can be defined as follows [11, 12, 13, 14]:
  - Pressure cycled—inspiration is cycled into expiration after exceeding the pressure threshold. It is mainly used as a safety feature for precluding high inspiratory pressures.
  - Volume cycled—inspiration is discontinued after delivering the set tidal volume.
  - Time cycled—inspiration is interrupted after reaching the time threshold. The threshold is defined by setting the respiratory rate, inspiratory time or inspiratory/expiratory ratio.
  - Flow cycled—breath is terminated after flow patterns falls to a certain set level.
4. Expiration phase is following the cycling process and it is in most of the cases a passive procedure. Its duration is dependent of elastance and resistance of the patient's breathing system [12, 13].

## **MODES OF POSITIVE-PRESSURE VENTILATION**

Modes of positive-pressure ventilation are categorized by following criteria:

1. Type of breath: Three types of breath can be provided during mechanical ventilation—controlled, assisted, or supported. Controlled breaths are imposed regardless of the patient's inspiratory effort, contrarywise, assisted breaths and supported breaths are synchronized with the patient's inspiratory effort [13, 17].
2. Breath sequence: The breath sequence can be described by Continuous mandatory ventilation (CMV, all breaths are mandatory), Intermittent mandatory ventilation (IMV, breaths can be either mandatory or spontaneous), Continuous spontaneous ventilation (CSV, all breaths are spontaneous) [13, 15].

3. Specific control strategy: The specific control strategy is ensured by trigger, limit, and breath cycling [15].

Relations between all these factors and their combinations create numerous ventilation modes. The list of typical ventilation modes used during the mechanical ventilation is listed below [3].

- **Continuous mandatory ventilation (CMV)**—CMV ensures delivery of a set minute ventilation (tidal volume multiplied by respiratory rate). Each tidal volume is achieved by constant flow and the peak pressure changes accordingly to the airway compliance and resistance. The minimal minute ventilation is predefined and thus ‘mandated’. The patient’s inspiratory effort is not supported during the ventilation. It is the basic form of ventilation that had been traditionally found among the first positive-pressure types of ventilators. Such form of ventilation refers to conventional mechanical ventilation as it presents a long time used standard. The mode is recommended to be set in use with fully sedated patients or patients in coma. This mode is common for anesthesia and ICU ventilators (Figure 1) [17, 19, 35].

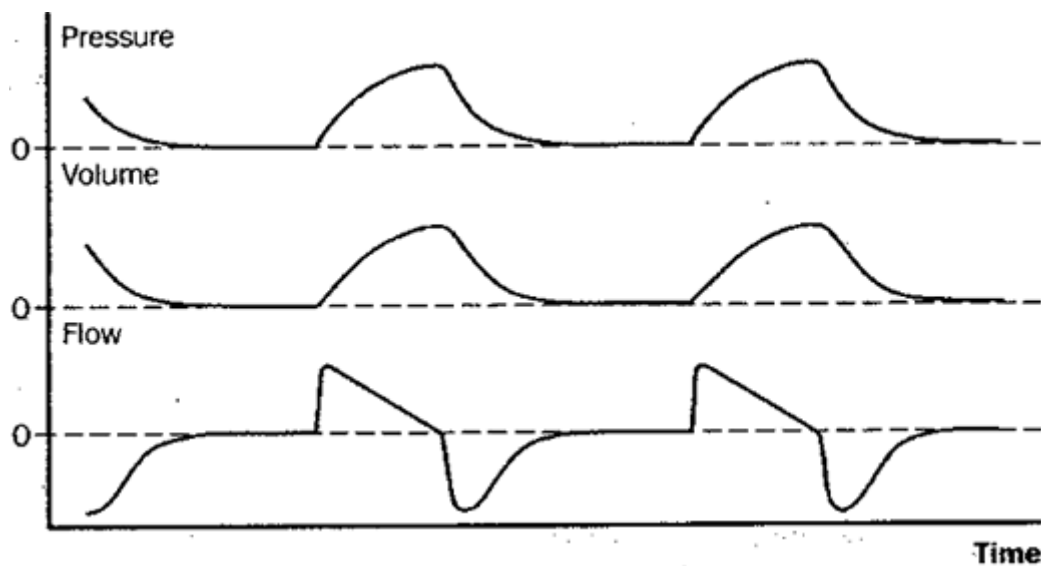


Figure 1: The pressure, volume and flow curve during CMV mode [16].

- **Pressure control ventilation (PCV)**—basic mode, it has similar function as CMV but it is pressure limited (instead of volume limited). The desired pressure level is set together with inspiratory time and respiratory rate. The flow decelerates during the inspiration until a preset pressure level is reached. The volume of inspired breath depends on the lung compliance and resistance. It is a mode found among anesthesia and ICU ventilators [14, 17, 19].
- **Assist control ventilation (ACV)**—ACV mode delivers pre-set breaths with every detected inspiratory effort generated by the patient. The patient cannot breathe without ventilation assistance, however, can initiate the inspiration and influence the

respiratory rate. If the patient fails to inhale, the ventilator automatically delivers tidal volume comparable to those delivered with the inspiratory effort. A patient showing no effort would be delivered sufficient minute volume delivery purely by the ventilator. Contrary to that, hyperinflation might be induced with patients having high respiratory rate. There are both pressure assist (PA/C) and volume assist ventilation (VA/C) modes available. It is found among ICU ventilators (Figure 2) [14, 17].

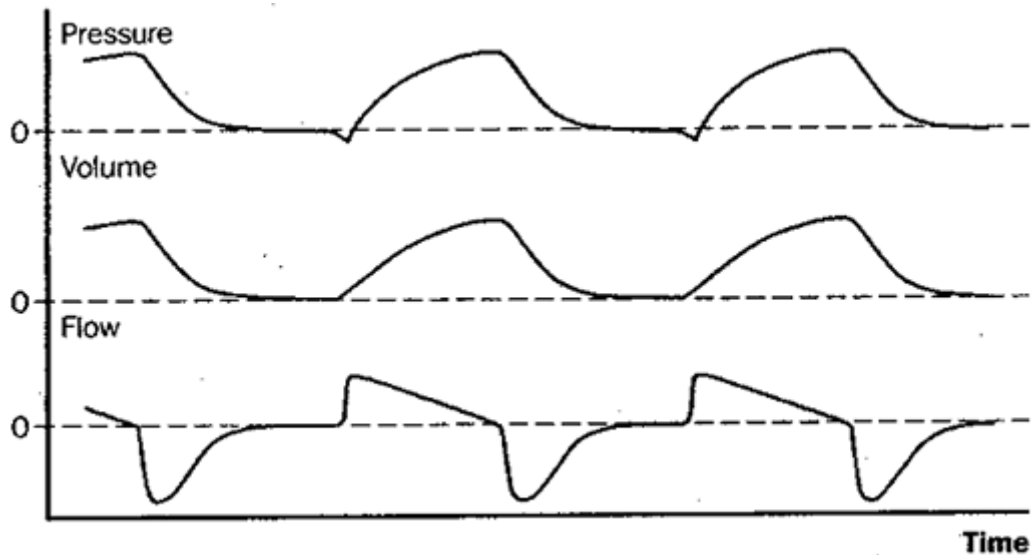


Figure 2: The pressure, volume and flow curve during AC mode [16].

- **Synchronized intermittent mandatory ventilation (SIMV)**—a set number of breaths per minute is synchronized with the detected inspiratory effort and subsequently fully supported by the ventilator. If the patient's breathing frequency exceeds the pre-set respiratory rate on the ventilator, the patient can additionally breathe in between the supported breaths. To minimize the work of breathing, these additional breaths are pressure or volume supported. This mode is combining two modes at once and is considered as a possible tool for initiating patient's weaning. This mode exists as pressure-based (SIMV-PC/PSV) or volume-based (SIMV-VC). This ventilation mode is intended for ICU and anesthesia ventilators (Figure 3) [11, 12, 19].

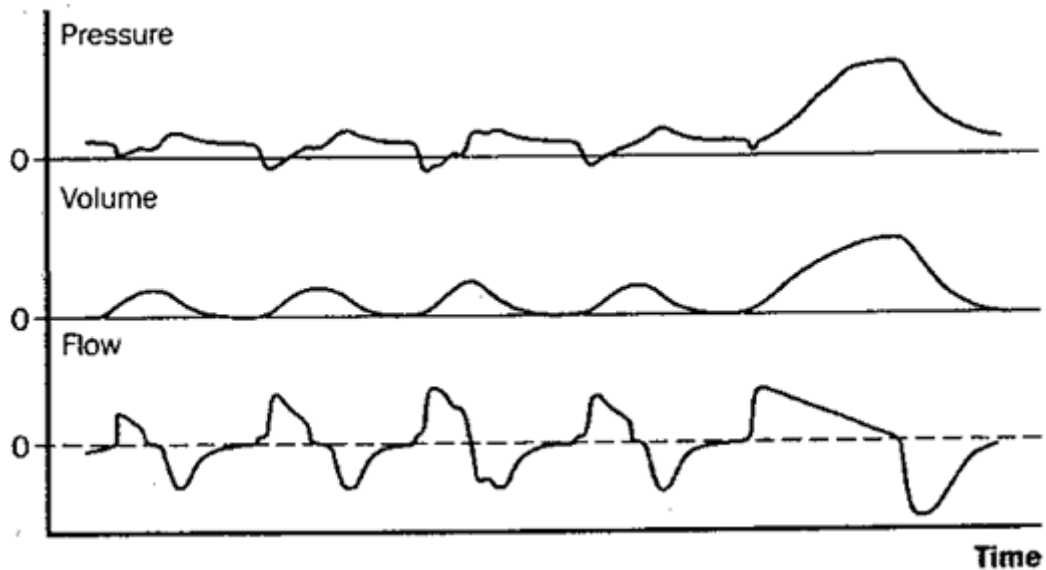


Figure 3: The pressure, volume and flow curve during SIMV mode [16].

- Pressure support ventilation (PSV)**—PSV supports every spontaneous breath with inspiratory pressure support and its termination is cycled by inspiratory flow rather than time. The breath flow has to decline to a certain threshold (usually ranging from 10 – 25 % of the peak flow) to switch the inspiration phase to expiration. The patient determines the respiratory rate, inspiratory time, and tidal volume. Compared to other modes described above, the PSV assist only breaths initiated by the patient. As a result, patients with weak or unstable inspiratory effort or heavily sedated patients may not profit from such setting and should be provided with alternative ventilation mode. PSV is popular for patient’s weaning. PSV is designed in pressure-based mode only and it is introduced in both types of ventilators (Figure 4) [11, 15, 35].

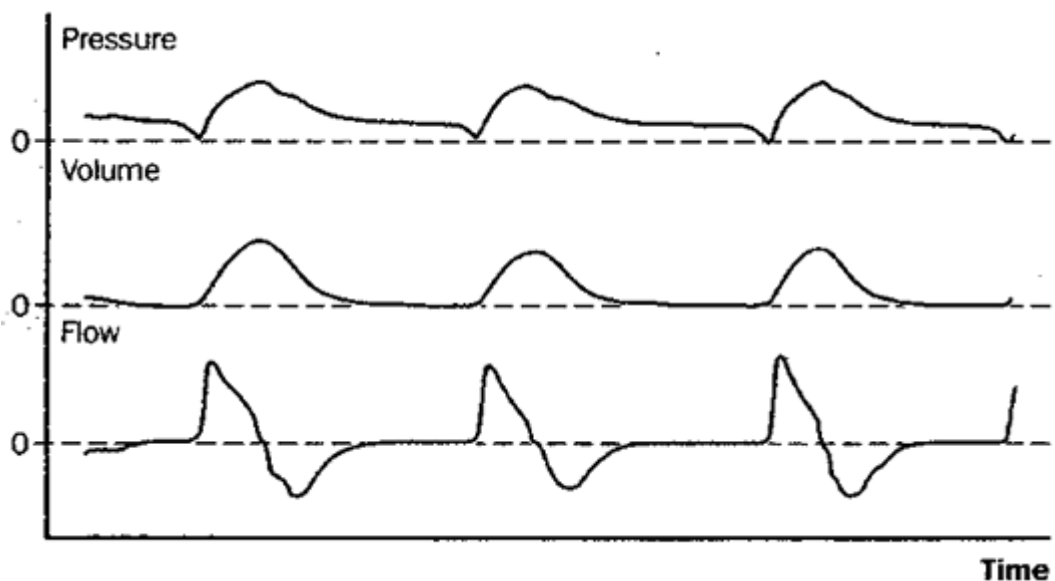


Figure 4: The pressure, volume and flow curve during PSV mode [16].

There is also a vast variety of different optional modes that have been derived from these basic modes, such as Intermittent Mandatory Ventilation (IMV), Airway Pressure Release Ventilation, Biphasic Positive Airway Pressure (BIPAP) or Continuous Positive Airway Pressure (CPAP) and many others. A great deal of new ventilation modes had been introduced with new mechanical ventilators reaching the markets. The ventilator manufacturers do not adhere to any standardized nomenclature for defining newly developed ventilation modes, and the terminology can be misleading for the medical staff providers [1, 12, 15, 17]

## VENTILATOR SETTINGS

When connecting a patient to the ventilator, it is essential to select the correct ventilation mode and ventilator setting. The standard modes were discussed in previous chapter, and this section is devoted to common ventilator settings.

The basic ventilator settings are as follows:

- **Respiratory rate**—the number of breaths delivered by the ventilation per one minute. The normal range varies between 8 to 12 breaths and may be adjusted to keep normal O<sub>2</sub> and CO<sub>2</sub> levels [11].
- **Inspiratory/Expiratory ratio**—it is the ratio between the duration of inspiration and expiration. The normal setting is 1:2 meaning the expiration is twice longer than inspiration. Longer expiration phase is advised with patients suffering from COPD to avoid air trapping. Reverse ratio 2:1 is shortly used with patients having oxygenation shortfall [11].
- **Fraction of inspired oxygen**—the fraction of oxygen present in the delivered gas mixture expressed as a percentage (or number between zero and one). It ranges from 21 to 100 % depending on the patient's health condition, and the proper value can be determined according to arterial blood gases analysis and pulse oximetry values [10, 11].
- **Tidal volume**—used in volume controlled mechanical ventilation. Volume control is the total gas volume delivered to the patient at the end of the inspiration, called tidal volume. The recommended protective tidal volumes vary from 6 mL/kg to 8 mL/kg to reduce the risk of pulmonary barotrauma (mainly with the patients suffering from significant lung disease or trauma). The tidal volume with healthy patients can reach up to 10 mL/kg or more [24].
- **Inspiratory flow**—the set flow value to deliver tidal volume (used with volume control ventilation), which is normally around 60 L/min [18].



- **Peak inspiratory pressure**—used during pressure-limited mechanical ventilation and it is an alternative to volume control ventilation. It is the highest value of pressure reached during the inspiratory phase. The threshold is usually set at maximum 40 cm H<sub>2</sub>O to avoid the risk of barotrauma [21, 22].
- **PEEP**—refers to positive end-expiratory pressure, and it is the pressure in lungs above atmospheric pressure at the end of the expiration. PEEP combined with low tidal volumes reduces the prevalence or ventilator-induced lung injury (VILI), it may also reduce the risk of atelectasis by recruiting alveolar units and improve oxygenation. Typical PEEP values are selected according to individual lung pathology of the patient. The set PEEP values may range from 0 cm H<sub>2</sub>O to approximately 20 cm H<sub>2</sub>O. The optimal level can be assessed by lung mechanics or gas exchange observations [20, 29].

### 1.1.2 ICU and anesthesia machine design

ICU and anesthesia machine ventilators use diverse control and circuit construction. ICU ventilators vent exhaled gases into the atmosphere and directly release gas from the wall outlet into the circuit meaning that they possess a small internal circuit volume. An electrically driven piston or turbine is used for creating the driving inspiratory pressure and flow.

In general, breathing systems can be classified as:

- Open
- Semi-open
- Closed
- Semi-closed

This classification is based on the recirculation of the exhaled gases in the breathing circuit. The semi-open circuit is also called the Mapleson breathing system. The semi-closed and closed circuits are together known as the circle system. The Mapleson and the circle breathing systems are the most common circuits used in the anesthesiology [31, 32].

#### MAPLESON SYSTEM

There are 5 different arrangements of the Mapleson system—A, B, C, D, E, F [31]. The Mapleson breathing system is used for delivering oxygen and the anesthesia agents to the patients and eliminating carbon dioxide during anesthesia. The circuit basically consists of following parts (1) Face mask, (2) Reservoir bag—for accommodating fresh gas flow during the patient's expiratory phase and also functions as a reservoir bag, (3) Breathing tube—between the face mask and the reservoir bag, (4) Fresh gas flow inlet—at variable position, (5) Expiratory valve or Adjustable Pressure Limiting (APL)

valve—allows gases to escape during the patient’s expiration. The different arrangements of these components define each type of the Mapleson system (Figure 5). Unlike the circle systems, all expired gases are directed outside the breathing circuit and the fresh gas flow inlet is not located at the patient’s end but on the other side [33].

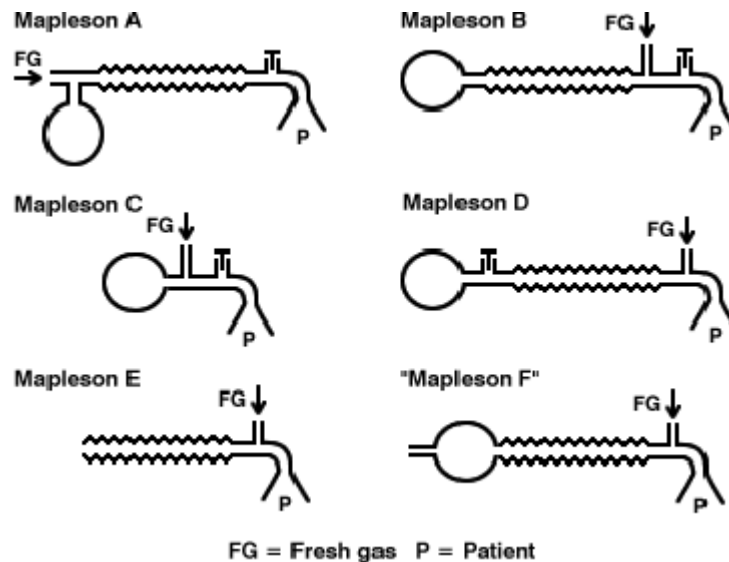


Figure 5: Different types of the Mapleson systems [30].

## CIRCLE SYSTEM

The circle system can be semi-closed—which means that the part of the gas is released thru the APL valve located in the breathing circuit, or closed—there is a total rebreathing of the exhaled air in the breathing circuit [31, 32].

Furthermore, the circle system can be classified as a double-circuit (one circuit for the patient gas and the second one for driving gas) or single circuit. The double circuit (Figure 6) involves bellows located in a rigid plastic chamber that are pneumatically compressed by driving gas (mix of oxygen and air) during the inspiratory phase, and the gases inside are subsequently delivered to the patient. Single circuit (Figure 7) uses computer-controlled piston or turbine to compress the gas in the breathing circuit, thus creating inspiratory motive force. The gas driving force is replaced by electricity instead. This system offers higher accuracy in volume delivery [2, 24].

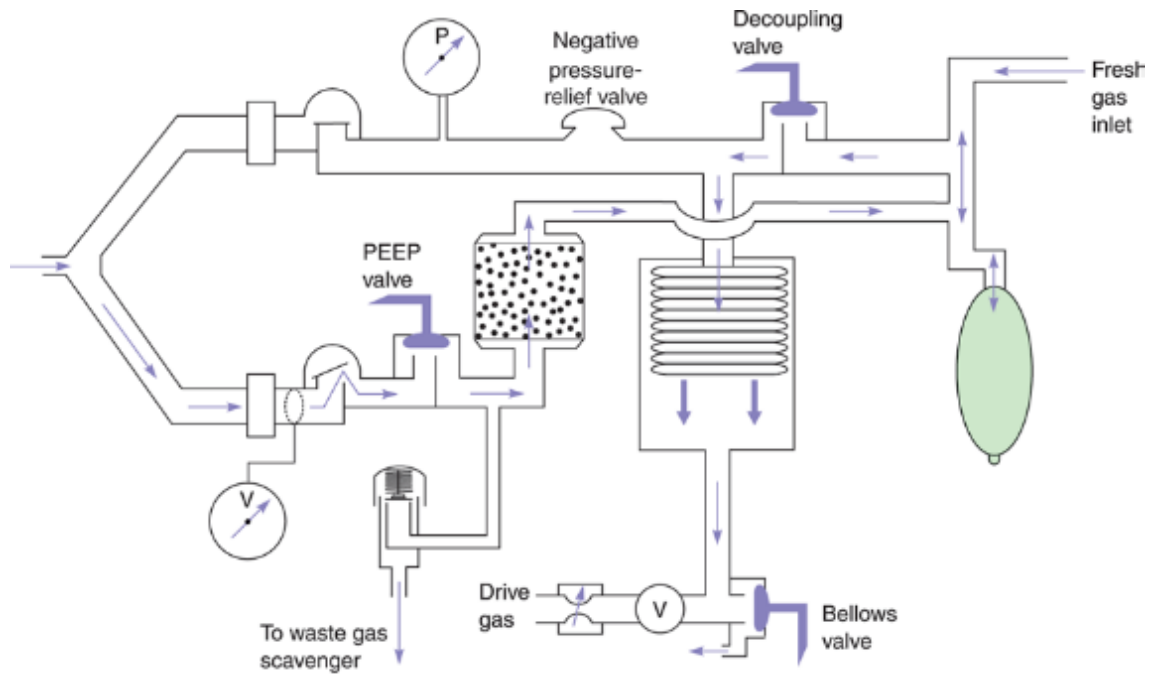


Figure 6: Description of an anesthesia circuit using the bellows-drive system [23].

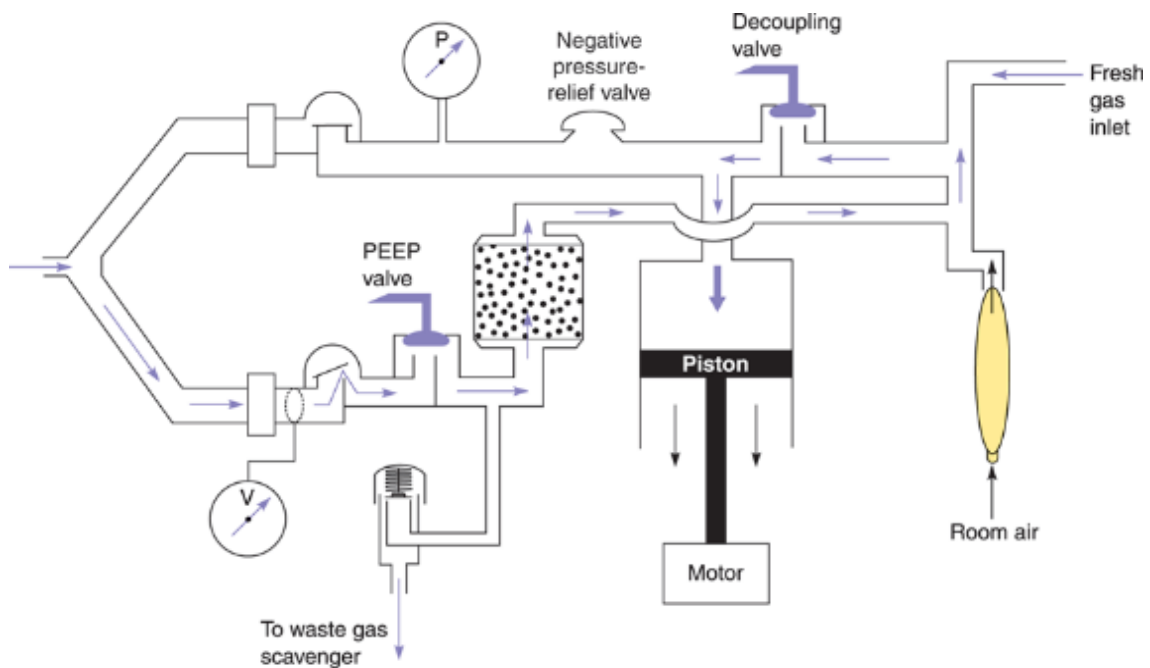


Figure 7: Description of an anesthesia circuit using the piston-drive system [23].

Anesthesia breathing circuit is formed by inspiratory and expiratory limb. The inspiratory limb serves for fresh gas delivery to the patient and expiratory limb enables patient to exhale. Typical anesthesia circuit comprises of (1) Soda lime absorber—present in the inspiratory limb (or in the expiratory limb with newer anesthesia machines) to clear the inspiratory gas of  $\text{CO}_2$  before entering the patient, (2) Two unidirectional valves—in the inspiratory and expiratory limb, which allow the gas flow to move only in one direction and impedes revers flow, (3) Fresh gas inlet—delivers fresh mixture of medical gases into

the system (4) Y-piece—an entry for connecting the breathing system with the patient, (5) APL valve—allows excessive exhaled waste gases and fresh gas flow to leave the circuit, (6) Reservoir bag—plastic bag that accommodates fresh gas flow during expiration and acts as an air reservoir for next breath delivery, (7) Breathing hoses—for airway circulation [24, 25].

One significant difference between ICU and anesthesia ventilator is in their internal compliance, where ICU ventilators with open-circuit design have low internal compliance and anesthesia ventilators, owing to presence of the CO<sub>2</sub> absorber and bellows (or piston), have large compliance. Typical volumes for older anesthesia ventilators are ranging between 6.000 mL to 7.000 mL, whilst ICU ventilators internal volumes can reach less than 100 mL [3]

### **LIMITATIONS OF ANESTHESIA MACHINES**

This high internal volume limits the anesthesia machine in two main aspects.

1. Incapability to deliver precise gas volume when using the bellow – based ventilators.
2. Inability to deliver stable gas flow at high airway pressures.

There are several factors influencing the final tidal volume delivery reaching the patient. The amount of compressed gas in the bellows (not reaching the patient) is determined by the compliance of the ventilator, breathing circuit and, also the patient. If the patient's compliance abruptly attenuates during the inter – breath intervals, only the gas inside the ventilator is being compressed and the patient receives minimal volume. Neonates and pediatric patients suffering from pulmonary diseases with typically low compliance and high resistance, are the most vulnerable group affected by this insufficiency.

Eventually a more significant drawback of the anesthesia ventilators underlays in the gas flow instability at high airway pressures. Delivering less gas flow at higher pressures results in decreased tidal volume (Figure 8). Both ventilator types should be able to deliver sufficient high gas flow to deliver desired tidal volume in case of shorter inspiratory time and moreover, should be capable to maintain steady gas flow regardless of changes in the lung compliance or resistance. This is followed by diminished tidal volume and enlarged airway pressures. Due to large internal volume causing higher compliance, a substantive fraction of the ventilator gas output is being compressed inside the circuit and never targets the patient. The increasing airway pressure is proportional to increasing volume that is kept compressed inside. These limitations are not dangerous in normal clinical use. Although, trauma and burnt patients are representing the most susceptible examples, as they might be transported from ICU department to the surgery room. Unstable gas flow delivery at high pressure levels, noticeable for anesthesia ventilators, might deteriorate the gas exchange while undergoing operation [3, 26].

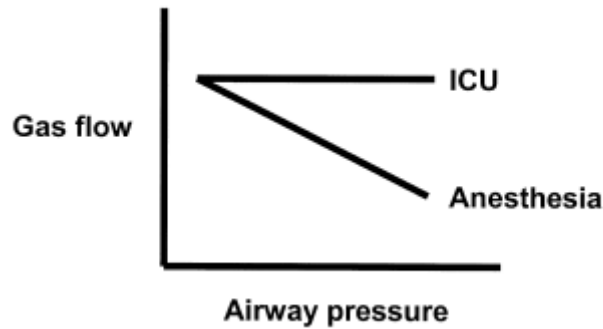


Figure 8: Dependency of delivered gas flow on increasing airway pressure and the comparison between anesthesia and ICU ventilator [3].

### NEWER ANESTHESIA MACHINES

Significant improvements have been implemented in modern anesthesia ventilators to prevent the abovementioned shortcomings, and many ventilator manufactures are aiming at lessening the differences between ICU and anesthesia ventilators.

The modern era ventilators are designed with smaller circuit volumes by placing the compartments closer together and introducing smaller bellows and CO<sub>2</sub> absorber [27]. Using the piston drive system instead of the bellow - driven system is one of the significant advancements. The connection of the piston and drive motor is rigid, and the delivered volume is directly related to the piston movement resulting in a more precise volume delivery. Piston ventilators are also able to compensate changes in compliance and to deliver additional volume. The self – test conduction helps to define the leaks and compliance of the patient and ventilator circuit, thus also contributes to more precise volume delivery [26]. Fresh gas flow decoupling represents another adjunct used for precise volume delivery. It eliminates the interaction between fresh gas flow and tidal volume delivered to the patient. A decoupling valve is placed between the fresh gas inlet and the breathing circuit. When the circuit is being pressured during the inspiratory phase, the decoupling valve closes and the fresh gas flows into the reservoir bag. Safer and more precise vaporizers are also part of the overall improvement. To give an example, the older anesthesia machines were incapable of delivering more than 50 L/min at the inspiratory pressure of 50 cm H<sub>2</sub>O, albeit, the newer anesthesia machines can deliver around 70 L/min at the inspiratory airway pressure of 70 cm H<sub>2</sub>O. This is still not equivalent to 120 L/min at the pressure of 90 cm H<sub>2</sub>O with ICU ventilators but sufficient to support patients with severe inspiratory insufficiency [3, 28].

Another substantial progress has been conducted in the ventilation mode availability. Many ventilation modes that had been limited only to ICU ventilators, have gradually become standard equipment of the anesthesia machines. The initial fixed-flow, volume control ventilation, has been replaced by mainly partial pressure modalities as PCV, PSV or SIMV, to potentially suit the needs of the critically ill patients. Little data exist to specifically prove the advantages of such modes with anesthesia ventilators, as well as

the cases indicating their implementation, which can have unforeseen effects with anesthesia ventilators [1, 3].

At the ICU department, the PCV mode is generally used to treat patients with respiratory failures typically linked with low lung compliance and enlarged intrapulmonary shunting, as they are not able to maintain stable gas exchange with the volume control mode. Another possible usage can be considered during one – lung ventilation or with the use of laryngeal mask to achieve more effective gas exchange. One plausible application is for the patients with a narrow or obstructed EET tube. The fixed-flow rate characteristic for volume control ventilation results in high peak airway pressure with increased resistance of the endotracheal tube, which can eventually impose excessive lung pressure. However, it is inevitable to realize that anesthesia machines' maximum flow rate is lower than with ICU. An incorrect setting of the inspiratory time can lead to limited tidal volume delivery. This imperfection has to be considered during the transition from the ICU department to the operational room [3].

The application of SIMV mode can be applied as a safeguard when retrieving spontaneous ventilation at the end of the surgery. The SIMV can substitute manual ventilation, needing a continuous surveillance, by setting low respiratory rate until spontaneous breathing is restarted. Otherwise, there are no determined clinical situations that would request the use of SIMV [3, 27].

The pressure support mode can find its possible use with anesthetized patients (mainly children) capable of spontaneous breathing. Some studies suggest that the use of laryngeal mask with PSV setting is having a positive impact on the work of breathing or exhaled CO<sub>2</sub> levels. The application of PSV might preserve spontaneous breathing, reduce the risk of atelectasis, increase tidal volumes with each spontaneous breath and eliminate anesthetic gas levels. It can also target a group of patients having narrow EET or EET obstruction as the pressure – based ventilation reaches tidal volumes at any inspiratory pressure value [3, 25, 27].

## **1.2 Aim of the thesis**

New sophisticated features and technologies were implemented into modern anesthesia machines to diminish the defects between the old generation of anesthesia and ICU ventilators. Therefore, it can be assumed that the modern anesthesia machines are able to ventilate the patient with comparable comfort and accuracy as the ICU ventilators. Such advancements might bring greater flexibility in the pre-operative care as any patient can be safely ventilated when being urgently transported from the ICU department to the operational room without the need for individual setting of the ventilator [1, 2, 4]

The general aim of this study was to compare the performance of anesthesia and intensive care ventilators under various health conditions of the patient (represented by a lung model) and different ventilation modes and settings. The performance was defined by the accuracy of peak inspiratory pressure, tidal volume and positive end-expiratory pressure (PEEP) delivered to the patient, and by the response rate to the patient's inspiratory effort during synchronized ventilation modes. For this purpose, the outcomes of three modern anesthesia ventilators and three intensive care ventilators were evaluated. Three generations of anesthesia machines from identical manufacturer were included to observe possible technical improvements between the older and newer models. One ICU ventilator from a distinct manufacturer was included to observe the technological differences.

The thesis was divided into several objectives to achieve the main goal. The first objective was to define the accuracy of the peak inspiratory pressure, tidal volume delivery and the PEEP delivered by the ventilator. The second objective was to test the triggering performance of the ventilators; that means to define if changeable lung compliance, resistance, and respiratory rate of the lung model have an impact on the ventilator's trigger response. And furthermore, to define if the trigger response varies under different ventilator settings, such as diverse ventilation modes, peak inspiratory pressure, tidal volume delivery, PEEP and respiratory rate. The third objective was to determine the possible imbalances in the performance between anesthesia and ICU ventilators and to determine during which settings and simulated health conditions the most significant differences were measured. As the last objective, it was desirable to compare the performance among the group of anesthesia ventilators and to determine possible technological advancements. Based on the outcomes of the study, the benefits of the synchronized ventilation modes with anesthesia ventilators, which have ambiguous purposes during the surgery, were discussed.

## 2 Materials and methods

### 2.1 Ventilators tested

Three anesthesia ventilators and three ICU ventilators were used for data acquisition. Two anesthesia ventilators and three ICU ventilators were used at daily hospital operations and the third anesthesia ventilator included in the study was used for scientific and educational purposes at the Department of Biomedical Engineering, CTU (Table 1). All included ventilators were operable and regularly subjected to technical controls. The ventilators were handled and used in accordance with the manufacturer's specifications.

**Table 1: Characteristics of the tested ICU and anesthesia ventilators.**

<b>Ventilator</b>	<b>Manufacturer</b>	<b>Ventilator type</b>	<b>Inspiratory trigger</b>	<b>Internal flow generation</b>
Avea	CareFusion	ICU	Flow trigger (0.1–20 L/min)	Pneumatic
Evita XL	Dräger	ICU	Flow trigger (0.3–15 L/min)	Turbine
Infinity C500	Dräger	ICU	Flow trigger (0.2–15 L/min)	Turbine
Perseus	Dräger	Anesthesia	Flow trigger (0.3–15 L/min)	Turbine (TurboVent)
Primus	Dräger	Anesthesia	Flow trigger (0.3–15 L/min)	Piston
Zeus	Dräger	Anesthesia	Flow trigger (0.3–15 L/min)	Turbine (TurboVent)

### 2.2 Test lung model and test lung model setting

All ventilators were connected to a compartment breathing simulator ASL 5000 (IngMar Medical, Pittsburg, PA, USA). ASL 5000 is a digitally controlled device enabling simulation of various patient's scenarios. The device is based on a piston moving inside a cylinder that is computer-controlled to accomplish a motion. The simulator was attached to each ventilator and a computer for its controlling and subsequent data acquisition. VT PLUS (Fluke) gas flow analyzer was placed in between the ventilator and the ASL 5000 for continuous surveillance of the processed data. The sampled data was stored in the connected computer (Figure 9).



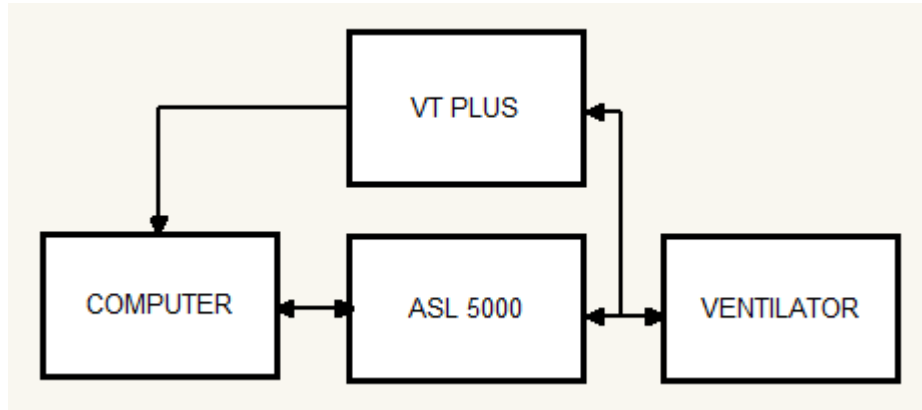


Figure 9: Scheme of the experimental setup (own source).

The detailed setting for an individual breath was set as follows:

- Active inspiratory phase with half-sinusoid curve
- Uncompensated residual capacity: 300 mL
- Patient's inspiratory effort: -5 cm H<sub>2</sub>O
- Inspiratory time: 20 %, Inspiratory holding time: 2%, Inspiratory release time: 5 %,
- Respiratory rate 12 BPM and 20 BPM

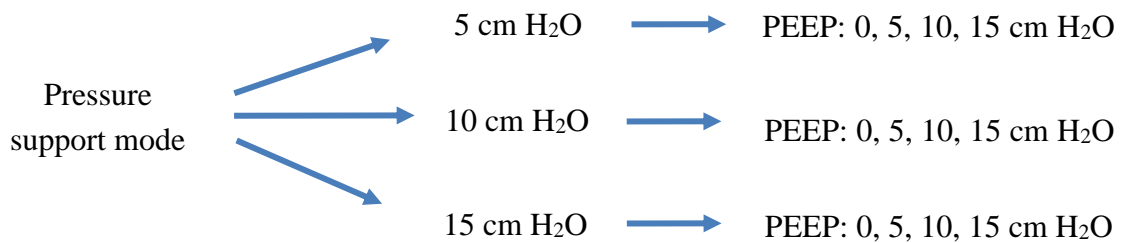
Table 2: Different values of compliance and resistance set on the ASL 5000 lung model.

Lung Model	Compliance (mL/cm H <sub>2</sub> O)	Resistance (cm H <sub>2</sub> O·s/L)
Healthy	60	3
COPD	80	10
ARDS	30	7.5

### 2.3 Ventilator setting

Each ventilator was tested under the simulation of 3 patient models describing healthy, COPD and ARDS condition. All of the conditions were tested with respiratory rate 12 BPM and 20 BPM. The ventilator setting was specifically changed during each simulation, plus during normal and high respiratory rate. The ventilator was first measured during pressure support mode for all of the simulated conditions and followingly switched to volume support mode.

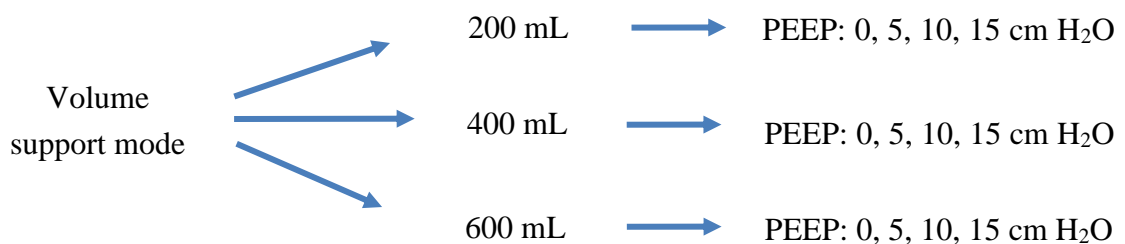
**Ventilator settings during one type of the simulation setting in pressure support mode:**



**Other ventilator settings:**

- Respiratory rate 12 or 20 BPM (corresponding to respiratory rate set on the simulator)
- The inspiratory and expiratory time ratio was set to 1:2
- $FiO_2 = 25\%$

**Ventilator settings during one type of the simulation setting in volume support mode:**



**Other ventilator settings:**

- Respiratory rate 12 or 20 BPM (corresponding to respiratory rate set on the simulator)
- The inspiratory and expiratory time ratio was set to 1:2
- $FiO_2 = 25\%$
- Maximum peak flow = 80 L/min

Based on the diagram above, there were 12 different ventilator settings for each simulated condition. There were 3 conditions measured with the respiratory rate 12 and 20 BPM, which makes 72 different combinations during pressure support mode (PCV) and 72 different combinations during volume support mode (VCV) for each ventilator. The protocol of measurement for PCV and VCV ventilation used for each ventilator is attached in the Appendix A and Appendix B.

The ventilators were tested in synchronized modes with the patient's inspiratory effort. To test the accuracy of preset pressure/volume, PEEP and the trigger response to the patient's inspiratory effort simultaneously, SIMV-PC or PA/C mode was used during pressure control ventilation and SIMV-VC or VA/C during volume control ventilation.

The specific mode selection was set according to individual mode availability of each ventilator (Table 3). There was a flow trigger available with all of the ventilators which was set at 1 L/min and first tested to avoid ventilator auto-triggering.

**Table 3: The selected ventilation mode for all ventilators during PCV and VCV ventilation.**

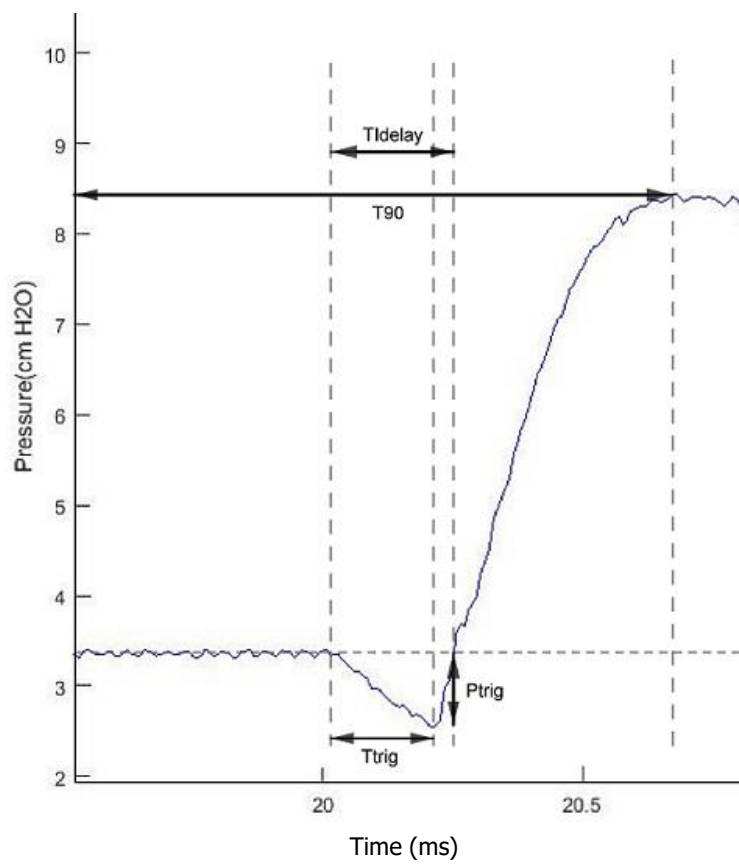
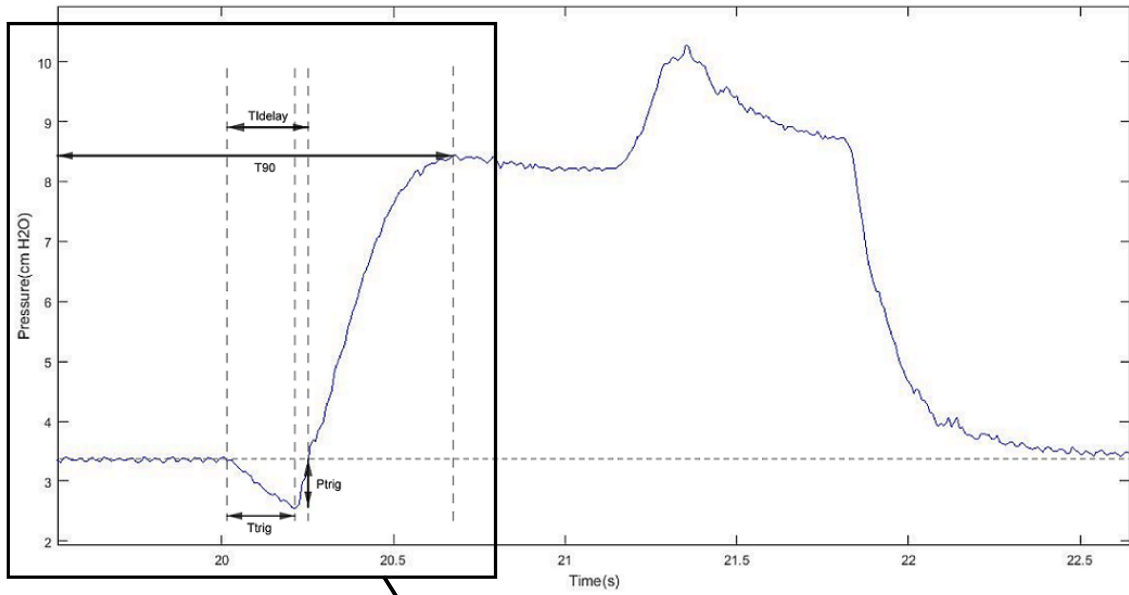
	Selected mode	
	PCV	VCV
Avea (CareFusion)	SIMV-PC	SIMV-VC
Evita XL (Dräger)	SIMV-PC	SIMV-VC
Infinity C500 (Dräger)	PA/C	VA/C
Perseus (Dräger)	SIMV-PC	SIMV-VC
Primus (Dräger)	PA/C	VA/C
Zeus (Dräger)	SIMV-PC	SIMV-VC

## 2.4 Variables evaluated

The ventilators were evaluated with the following variables (first three variables were measured to assess the accuracy of volume and pressure delivery of the ventilators and the four last ones to evaluate the triggering functionality):

- Tidal volume ( $V_T$ ): the total volume (in mL) delivered by the ventilator to the model at the end of the inspiration. The  $V_T$  setting is used during VCV ventilation.
- Peak inspiratory pressure ( $P_{IP}$ ): the highest level of pressure (in cm H<sub>2</sub>O) applied to the model by the ventilator at the end of the inspiration. The  $P_{IP}$  setting is used during PCV ventilation.
- Positive end-expiratory pressure (PEEP): the lung pressure (in cm H<sub>2</sub>O) at the end of the expiration phase maintained by the ventilator. The PEEP setting is used in PCV and VCV mode.
- Time to trigger ( $T_{trig}$ ): the time (in milliseconds) from the start of the breath to the maximum negative pressure deflection during patient's triggering (Figure 10).
- Pressure to trigger ( $P_{trig}$ ): The pressure difference (in cm H<sub>2</sub>O) between the initial airway pressure at the start of the breath and the maximum negative deflection in the airway pressure needed for triggering the ventilator (Figure 10).
- Inspiratory time delay ( $T_I$  delay): The time (in milliseconds) from the start of the inspiratory effort (causing the drop of the pressure to  $P_{trig}$ ) to the return of  $P_{trig}$  back to the baseline.  $T_I$  delay describes the whole process of ventilator triggering and the ventilator's response rate to inspiratory effort (Figure 10).

- Time to 90 % of peak pressure ( $T_{90}$ ): The time (in milliseconds) from the ventilator triggering point to the point when the delivered airway pressure reaches 90 % of the peak value. The  $T_{90}$  was measured only during the pressure support mode because volume support mode operates with fixed flow pattern only (Figure 10).



**Figure 10: Description of the evaluated trigger variables during PCV mode (the first graph describes the pressure curve with the propagated inspiratory effort, the second graph shows detailed description of the evaluated triggering variables).**

## 2.5 Data collection and analysis

The data captured with the ASL 5000 software was sampled with a frequency of 512 Hz and approximately 30 breaths were stored for later analysis. The captured data for each tested combination was firstly visually inspected and 5 representative breaths were selected for the analysis. The measured ventilator parameters were calculated by the ASL 5000 software or calculated manually, if the ASL software failed to detect correct values. The data analysis was conducted in MATLAB (MathWorks) software, version r2015b, Microsoft Excel 2016 (Microsoft Corporation), and STATISTICA 7.1 (StatSoft, Inc. 1984–2005). The results were represented as mean  $\pm$  standard deviation.

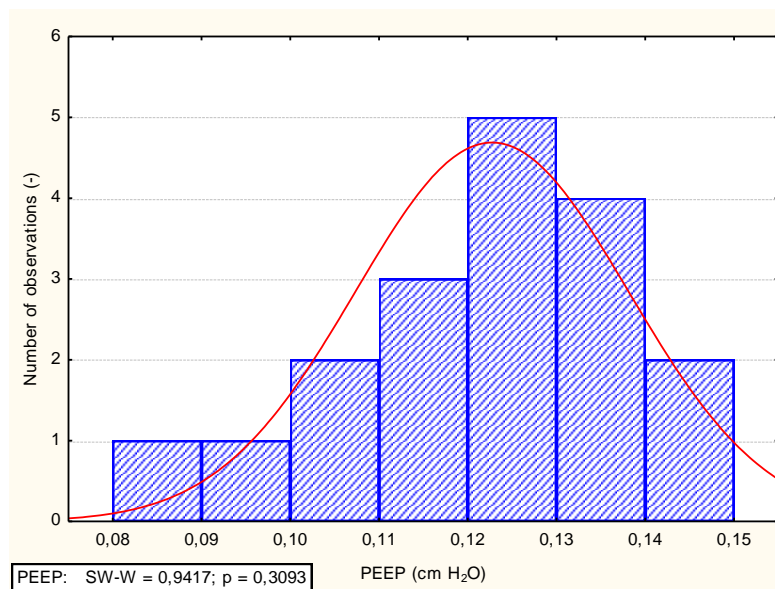
There was conducted the test of normality in STATISTICA 7.1 to test the normal distribution of the measured data. ANOVA analysis with additional Bonferroni correction was used for multiple comparisons of the delivered tidal volume, peak inspiratory pressure, PEEP and the overall triggering variables between the ventilators. ANOVA was also used for the comparison of the triggering variables under different peak inspiratory pressure values, tidal volumes, PEEP, respiratory rates and lung model settings for each of the ventilator. A paired *t-test* was used for the comparison of the triggering variables under various respiratory rate and ventilation mode for each of the ventilator. The ANOVA, Bonferroni correction analysis and the *t-test* was carried out in STATISTICA 7.1. The significance level was set at  $P < 0.05$ .

### 3 Results

The presentation of the results is compartmentalized into several subchapters. The first subchapter includes an example of the conducted normality test carried out on the measured data. The second subchapter compares the flow and pressure curves during one breath delivery by the ventilator to the lung model in PCV and VCV mode. The third subchapter is devoted to the representation of the measured peak inspiratory pressure and PEEP level delivery in PCV mode and tidal volume and PEEP level delivery in VCV mode among ventilators. The fourth subchapter deals with comparison of the ventilator's triggering capabilities under different settings of the peak inspiratory pressure, tidal volume, PEEP, respiratory rate and the lung model's setting. The last part gives an overview of overall triggering performance in PCV and VCV mode for each ventilator.

#### 3.1 Example of the normality test

The evaluated data from each ventilator was subjected to the normality test before the Anova analysis and the *t-test* was carried out. The figure below (Figure 11) represents an example of data with a normal distribution which was observed with most of the measured variables. Less than 5 % of the data didn't have normal distribution in our case. The normal distribution of the data is defined by the *p-value* value. The *p-value* has to exceed the significance level of 0.05 to meet the criteria of normality.



**Figure 11: Normal distribution of the PEEP values measured on Avea ventilator with all the tested combinations including the setting of PEEP = 0 cm H<sub>2</sub>O in PCV mode. The  $p = 0.3093 > 0.05$ .**

### 3.2 Overall ventilation pressure, volume and PEEP delivery

There were set three levels of peak inspiratory pressures and tidal volumes on the ventilator which were compared with the real ventilation support maintained by the machine during the ventilation. The results for delivered peak inspiratory pressure (Table 4) and tidal volume (Table 6) were obtained as mean  $\pm$  SD for all combinations including the same pressure or volume setting. The measured PEEP level during PCV (Table 5) and VCV (Table 7) was compared with the PEEP set on the ventilator. The maintenance of individual PEEP level was calculated as mean  $\pm$  SD for all combinations including the same PEEP setting, separately for PCV and VCV mode. The data was subjected to the normality test. ANOVA analysis with additional Bonferroni correction was used to determine significant differences for multiple comparisons.

**Table 4: The accuracy of set peak inspiratory pressure delivery in PCV mode between the tested ventilators.**

PCV (cm H <sub>2</sub> O)	Avea	Evita	Infinity XL	Perseus	Primus	Zeus
5	4,65 $\pm$ 0,67	5,94 $\pm$ 0,08 <sup>EIPZ</sup>	5,47 $\pm$ 0,34 <sup>EZ</sup>	6,52 $\pm$ 0,42 <sup>E</sup>	2,98 $\pm$ 0,87	5,46 $\pm$ 0,25 <sup>EI</sup>
10	9,83 $\pm$ 0,73	11,58 $\pm$ 0,20 <sup>Z</sup>	10,67 $\pm$ 0,15 <sup>Z</sup>	12,34 $\pm$ 0,71	8,88 $\pm$ 1,71	11,12 $\pm$ 0,38 <sup>EI</sup>
15	15,0 $\pm$ 0,76	17,15 $\pm$ 0,21	15,75 $\pm$ 0,68 <sup>Z</sup>	18,48 $\pm$ 0,75	14,10 $\pm$ 1,26	16,43 $\pm$ 0,52 <sup>I</sup>

<sup>E</sup>Peak inspiratory pressure is not significantly different from Evita

<sup>I</sup>Peak inspiratory pressure is not significantly different from Infinity XL

<sup>P</sup>Peak inspiratory pressure is not significantly different from Perseus

<sup>Z</sup>Peak inspiratory pressure is not significantly different from Zeus

**Table 5: The accuracy of set PEEP level in PCV mode between the tested ventilators.**

PEEP (cm H <sub>2</sub> O)	Avea	Evita	Infinity XL	Perseus	Primus	Zeus
0	0,12 $\pm$ 0,02 <sup>E</sup>	0,17 $\pm$ 0,09 <sup>A</sup>	0,46 $\pm$ 0,01 <sup>R</sup>	1,10 $\pm$ 0,09	0,45 $\pm$ 0,15 <sup>I</sup>	3,01 $\pm$ 0,31
5	3,64 $\pm$ 0,06	4,96 $\pm$ 0,08	5,28 $\pm$ 0,06 <sup>Z</sup>	4,67 $\pm$ 0,11 <sup>R</sup>	4,47 $\pm$ 0,20 <sup>P</sup>	5,25 $\pm$ 0,34 <sup>I</sup>
10	8,66 $\pm$ 0,06	10,12 $\pm$ 0,06 <sup>Z</sup>	10,49 $\pm$ 0,16 <sup>Z</sup>	9,79 $\pm$ 0,06 <sup>R</sup>	9,71 $\pm$ 0,26 <sup>P</sup>	10,31 $\pm$ 0,29 <sup>EI</sup>
15	13,72 $\pm$ 0,09	15,27 $\pm$ 0,03 <sup>R</sup>	15,54 $\pm$ 0,13 <sup>Z</sup>	14,87 $\pm$ 0,05	15,14 $\pm$ 0,33 <sup>E</sup>	15,69 $\pm$ 0,31 <sup>I</sup>

<sup>A</sup>PEEP level is not significantly different from Avea

<sup>E</sup>PEEP level is not significantly different from Evita

<sup>I</sup>PEEP level is not significantly different from Infinity XL

<sup>P</sup>PEEP level is not significantly different from Perseus

<sup>R</sup>PEEP level is not significantly different from Primus

<sup>Z</sup>PEEP level is not significantly different from Zeus



**Table 6: The accuracy of set tidal volume delivery in VCV mode between the tested ventilators.**

VCV (mL)	Avea	Evita	Infinity XL	Perseus	Primus	Zeus
200	188,04 ± 6,98 <sup>AIRZ</sup>	168,01 ± 7,35 <sup>Z</sup>	193,39 ± 5,99 <sup>APR</sup>	193,54 ± 9,74 <sup>AIRZ</sup>	189,46 ± 7,06 <sup>AIP</sup>	181,75 ± 8,52 <sup>AEIP</sup>
400	402,08 ± 38,85 <sup>I</sup>	351,52 ± 11,55 <sup>Z</sup>	398,31 ± 5,50 <sup>A</sup>	377,05 ± 9,20 <sup>R</sup>	377,63 ± 33,07 <sup>P</sup>	356,44 ± 13,59 <sup>E</sup>
600	561,92 ± 26,24 <sup>R</sup>	537,92 ± 3,49 <sup>P</sup>	623,45 ± 7,50	553,98 ± 22,01 <sup>AER</sup>	570,85 ± 4,03 <sup>AP</sup>	519,35 ± 10,28

<sup>A</sup>Delivered tidal volume is not significantly different from Avea

<sup>E</sup>Delivered tidal volume is not significantly different from Evita

<sup>I</sup>Delivered tidal volume is not significantly different from Infinity XL

<sup>P</sup>Delivered tidal volume is not significantly different from Perseus

<sup>R</sup>Delivered tidal volume is not significantly different from Primus

<sup>Z</sup>Delivered tidal volume is not significantly different from Zeus

**Table 7: The accuracy of set PEEP level in VCV mode between the tested ventilators.**

PEEP (cm H <sub>2</sub> O)	Avea	Evita	Infinity XL	Perseus	Primus	Zeus
0	0,14 ± 0,01 <sup>EIR</sup>	0,31 ± 0,23 <sup>AIR</sup>	0,46 ± 0,01 <sup>AER</sup>	1,10 ± 0,26	0,52 ± 0,12 <sup>AEI</sup>	2,58 ± 0,43
5	3,82 ± 0,14	5,63 ± 0,64 <sup>IZ</sup>	5,28 ± 0,06 <sup>EZ</sup>	4,62 ± 0,07 <sup>R</sup>	4,47 ± 0,27 <sup>P</sup>	5,62 ± 0,35 <sup>EI</sup>
10	8,83 ± 0,11	10,75 ± 0,73 <sup>IZ</sup>	10,49 ± 0,16 <sup>EZ</sup>	9,72 ± 0,08 <sup>R</sup>	9,78 ± 0,35 <sup>P</sup>	10,64 ± 0,80 <sup>EI</sup>
15	13,85 ± 0,10	15,29 ± 1,39 <sup>IR</sup>	15,54 ± 0,13 <sup>ERZ</sup>	14,72 ± 0,19 <sup>R</sup>	15,00 ± 0,33 <sup>EIP</sup>	15,82 ± 0,60 <sup>I</sup>

<sup>A</sup>PEEP level is not significantly different from Avea

<sup>E</sup>PEEP level is not significantly different from Evita

<sup>I</sup>PEEP level is not significantly different from Infinity XL

<sup>P</sup>PEEP level is not significantly different from Perseus

<sup>R</sup>PEEP level is not significantly different from Primus

<sup>Z</sup>PEEP level is not significantly different from Zeus

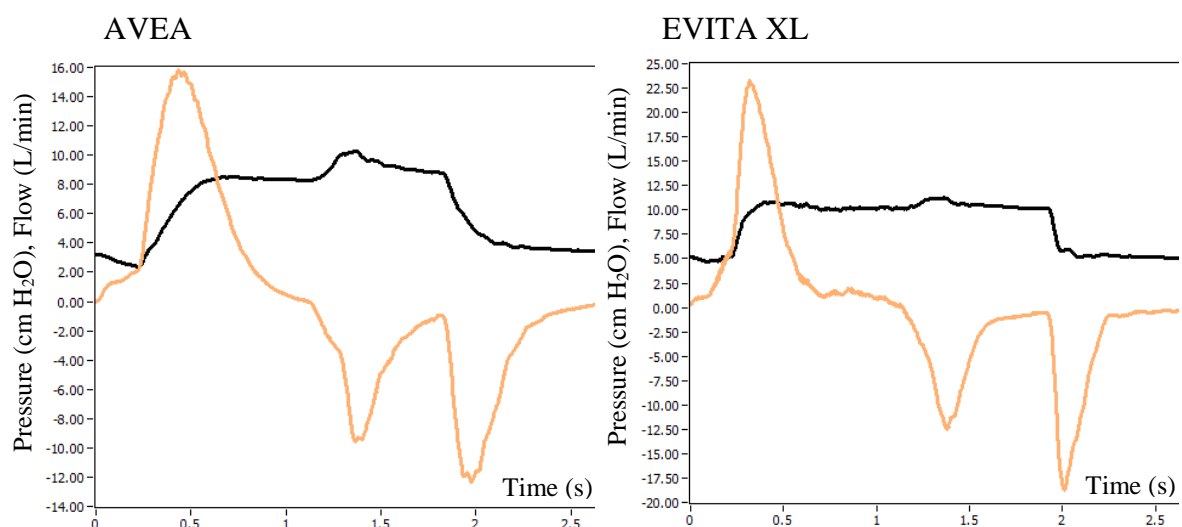
### 3.3 Difference between the pressure and flow curves during the breath triggering

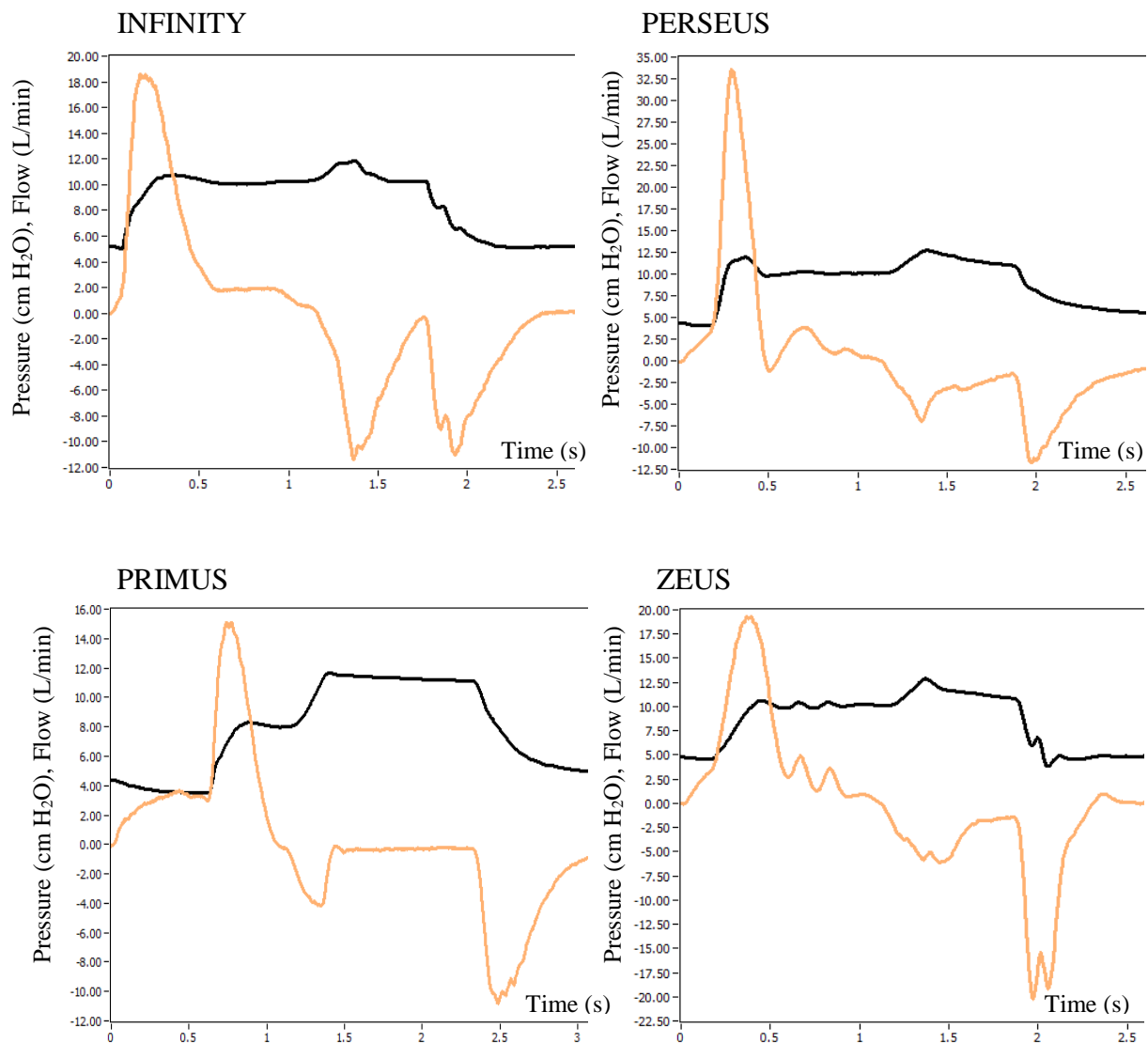
The pressure and flow curves were selected for one individual test combination which reported the overall largest value of the  $T_I$  delay parameter in PCV and VCV mode separately. The flow and pressure curves for one individual breath (under the specific test combination described below) was compared among the ventilators. The largest values were measured with the Primus ventilator in both ventilation modes. The largest value of the  $T_I$  delay parameter during PCV mode was measured under the following settings: COPD model ( $C = 80 \text{ mL/cm H}_2\text{O}$ ,  $R = 10 \text{ cm H}_2\text{O}\cdot\text{s/L}$ ), 12 BPM,  $P_{IP} = 10 \text{ cm H}_2\text{O}$  and  $PEEP = 5 \text{ cm H}_2\text{O}$ . The largest value of the  $T_I$  delay during VCV mode occurred under the following settings: COPD model ( $C = 80 \text{ mL/cm H}_2\text{O}$ ,  $R = 10 \text{ cm H}_2\text{O}\cdot\text{s/L}$ ), 12 BPM,  $P_{IP} = 5 \text{ cm H}_2\text{O}$  and  $PEEP = 10 \text{ cm H}_2\text{O}$ .

The  $T_I$  delay parameter describes the overall triggering capability of the ventilator as it defines the time from the start of the inspiratory effort to the return of the pressure to the baseline. The more prolonged and profound deflection in the pressure curve during the triggering phase, the longer it takes to the ventilator to respond to the patient's inspiratory effort. The steepness of the flow curve after triggering demonstrates the swiftness of the ventilator to deliver desired ventilation support.

The pressure and flow curves were captured and visualized by the ASL 5000 software. The zero-time value at the x-axis indicates the start of the inspiratory effort during one breath which is followed by the triggering phase—the pressure drops to a certain minimum level until the ventilator senses the inspiratory pressure and starts the breath delivery. The initiation of the breath delivery is also described by the accelerating flow curve pattern starting from the minimum pressure drop. The whole course of the curve describes the process of one synchronized breath delivered by the ventilator including the triggering phase, breath delivery, and the breath termination (Figure 12, 13) (Table 8,9).

#### 3.3.1 Pressure control ventilation





**Figure 12: The pressure curve (black) and the flow curve (orange) visually describes the triggering phase and the subsequent pressurization phase of the ventilators in the PCV mode.**

**Table 8: The value of the  $T_I$  delay parameter measured in PCV mode under the following test setting: COPD model ( $C = 80 \text{ mL/cm H}_2\text{O}$ ,  $R = 10 \text{ cm H}_2\text{O}\cdot\text{s/L}$ ), 12 BPM,  $P_{IP} = 10 \text{ cm H}_2\text{O}$  and  $PEEP = 5 \text{ cm H}_2\text{O}$ .**

Ventilator	$T_I$ delay (ms)
Avea	242,38
Evita XL	168,16
Infinity	77,93
Perseus	189,65
Primus	711,86
Zeus	187,70

There is a large difference between the  $T_I$  delay variable measured with Primus and the other ventilators. Longer triggering phase of the Primus ventilator is visible in the pressure curve of the ventilator (Figure 12).

### 3.3.2 Volume control ventilation

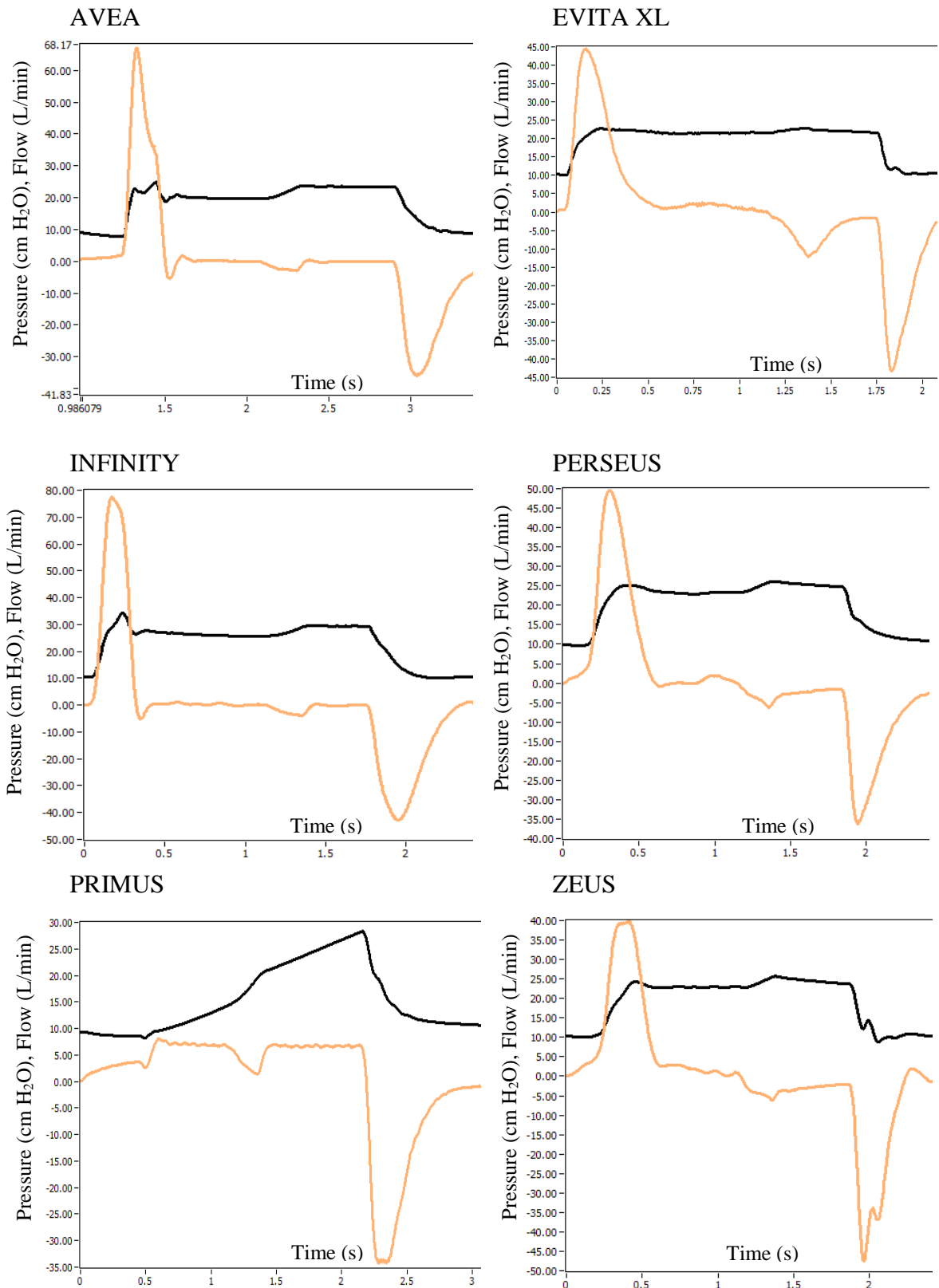


Figure 13: The pressure curve (black) and the flow curve (orange) visually describe the triggering phase and the subsequent pressurization phase of the ventilators in the VCV mode.

**Table 9: The value of the  $T_1$  delay parameter measured in VCV mode under the following test setting: COPD model ( $C = 80 \text{ mL/cm H}_2\text{O}$ ,  $R = 10 \text{ cm cm H}_2\text{O} \cdot \text{s/L}$ ), 12 BPM,  $P_{IP} = 5 \text{ cm H}_2\text{O}$  and  $PEEP = 10 \text{ cm H}_2\text{O}$ .**

<b>Ventilator</b>	<b><math>T_1</math> delay (ms)</b>
Avea	337,88
Evita XL	147,97
Infinity	51,76
Perseus	160,3
Primus	555,27
Zeus	190,43

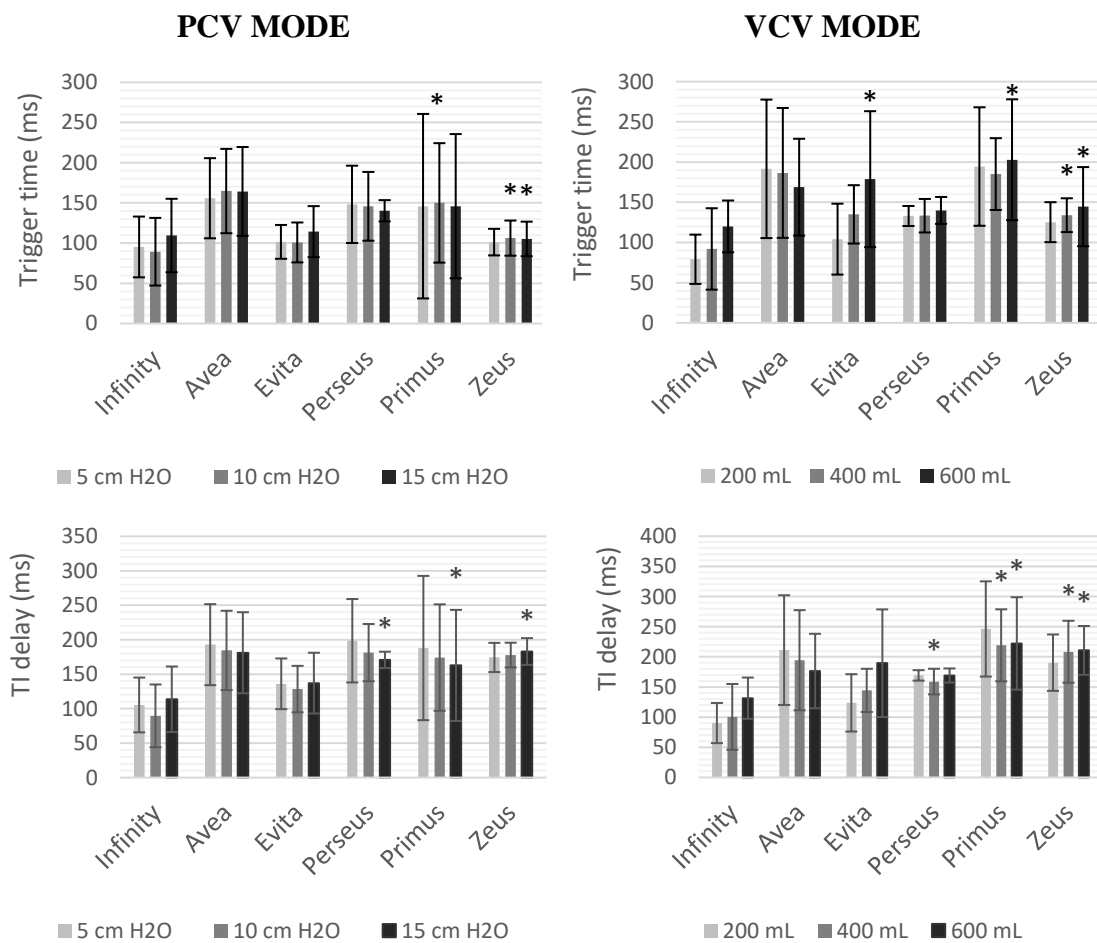
The  $T_1$  delay variable is significantly larger than with the rest of the ventilators. This is also visible in the pressure curve during triggering phase of the Primus ventilator (Figure13). Conversely, Infinity ventilator has the shortest  $T_1$  delay from all the ventilators which reflects in a small deflection in the pressure curve during the triggering phase of the ventilator.

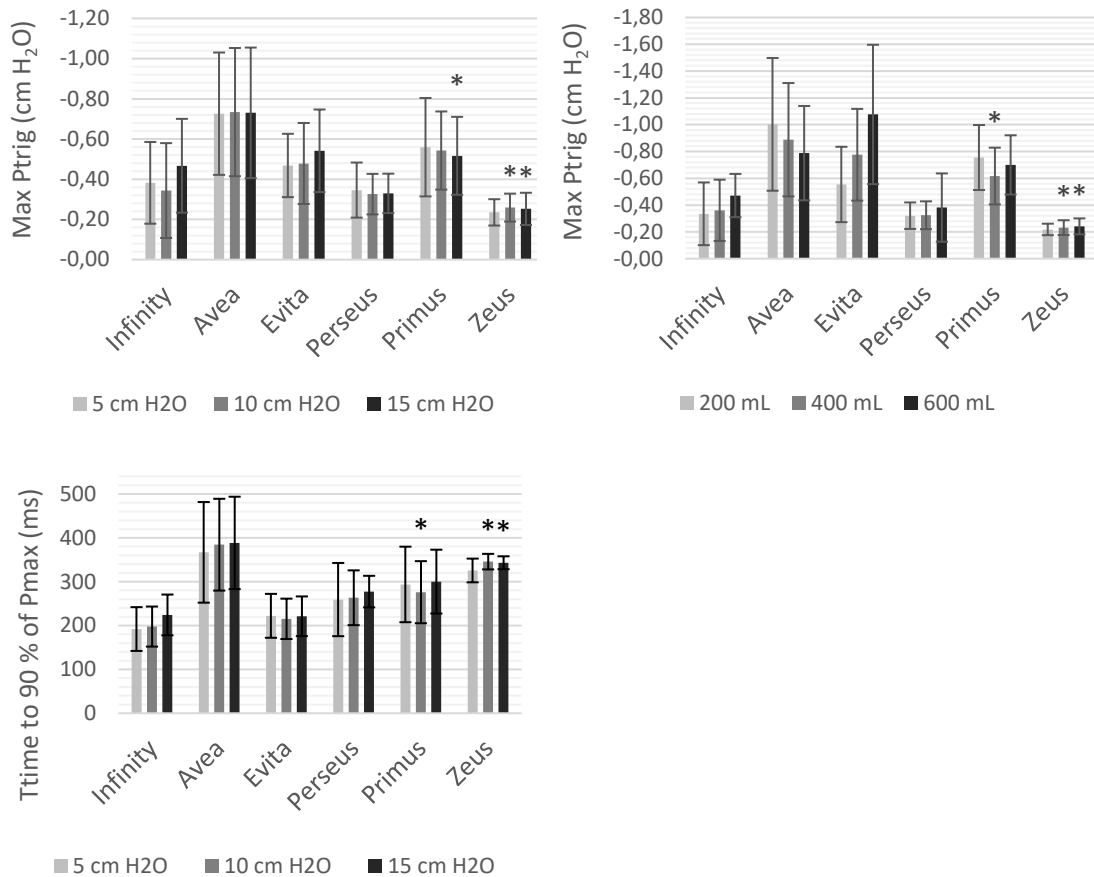
### 3.4 Effects of different model and simulator settings on the triggering performance

Different levels of peak inspiratory pressure and tidal volume, PEEP level, lung model's settings and respiratory rate were set to test the triggering performance of the ventilators. The evaluated variables were  $T_{trig}$ ,  $T_I$  delay, Max  $P_{trig}$  and  $T_{90}$ . All data was subjected to the normality test. ANOVA analysis with additional Bonferroni correction was used to determine significant differences for multiple comparisons of the variables and the paired *t*-test was used for two data set comparisons.

#### 3.4.1 Impact of various inspiratory peak pressures and tidal volumes

Individual triggering variables were calculated as a mean  $\pm$  SD in the Matlab Software for all settings including the same inspiratory peak pressure of 5, 10 or 15 cm H<sub>2</sub>O in PCV mode and same tidal volume delivery of 200, 400 or 600 mL in VCV mode (Figure 14). The symbol '\*' indicates significant differences compared to the first value of the peak inspiratory pressure or tidal volume (5 cm H<sub>2</sub>O in PCV mode, 200 mL in VCV mode).

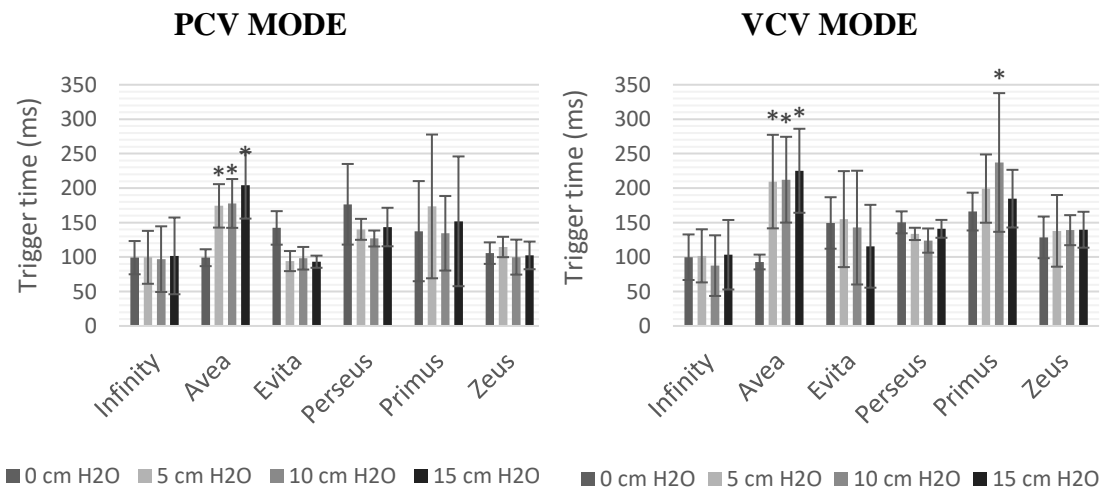


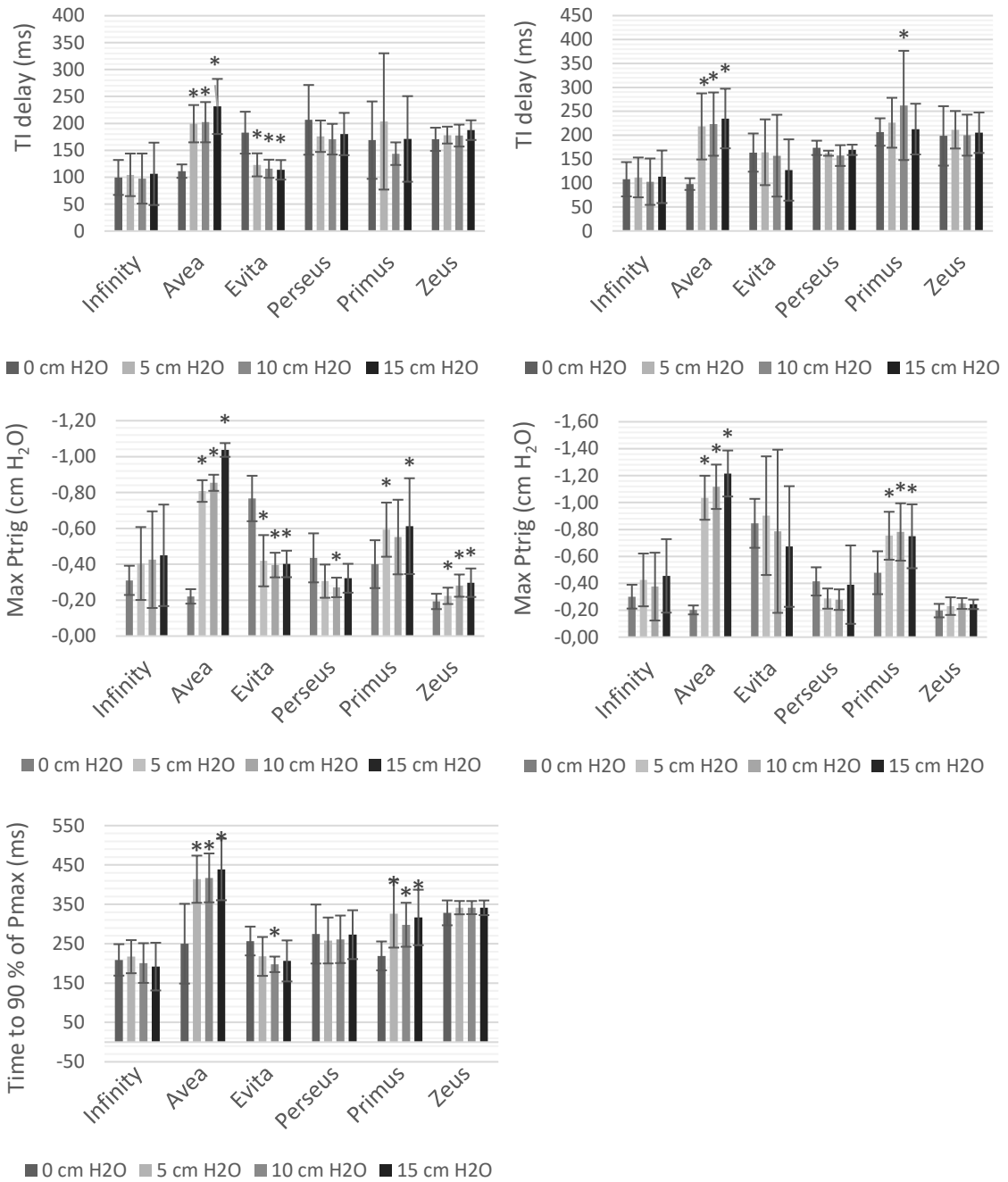


**Figure 14: The comparison of triggering variables for three various peak inspiratory pressure values in PCV (Figure aligned on the left side) and three various tidal volume values in VCV (Figures aligned on the right side) set on the ventilator under the same test conditions**

### 3.4.2 Impact of various PEEP levels

Individual parameters were calculated as a mean  $\pm$  SD in the Matlab Software for all settings including the same level of PEEP = 0, 5, 10 and 15 cm H<sub>2</sub>O in PCV and VCV mode separately (Figure 15). The ‘\*’ symbol indicates significant differences compared to the lowest PEEP level (0 cm H<sub>2</sub>O for both ventilation modes).



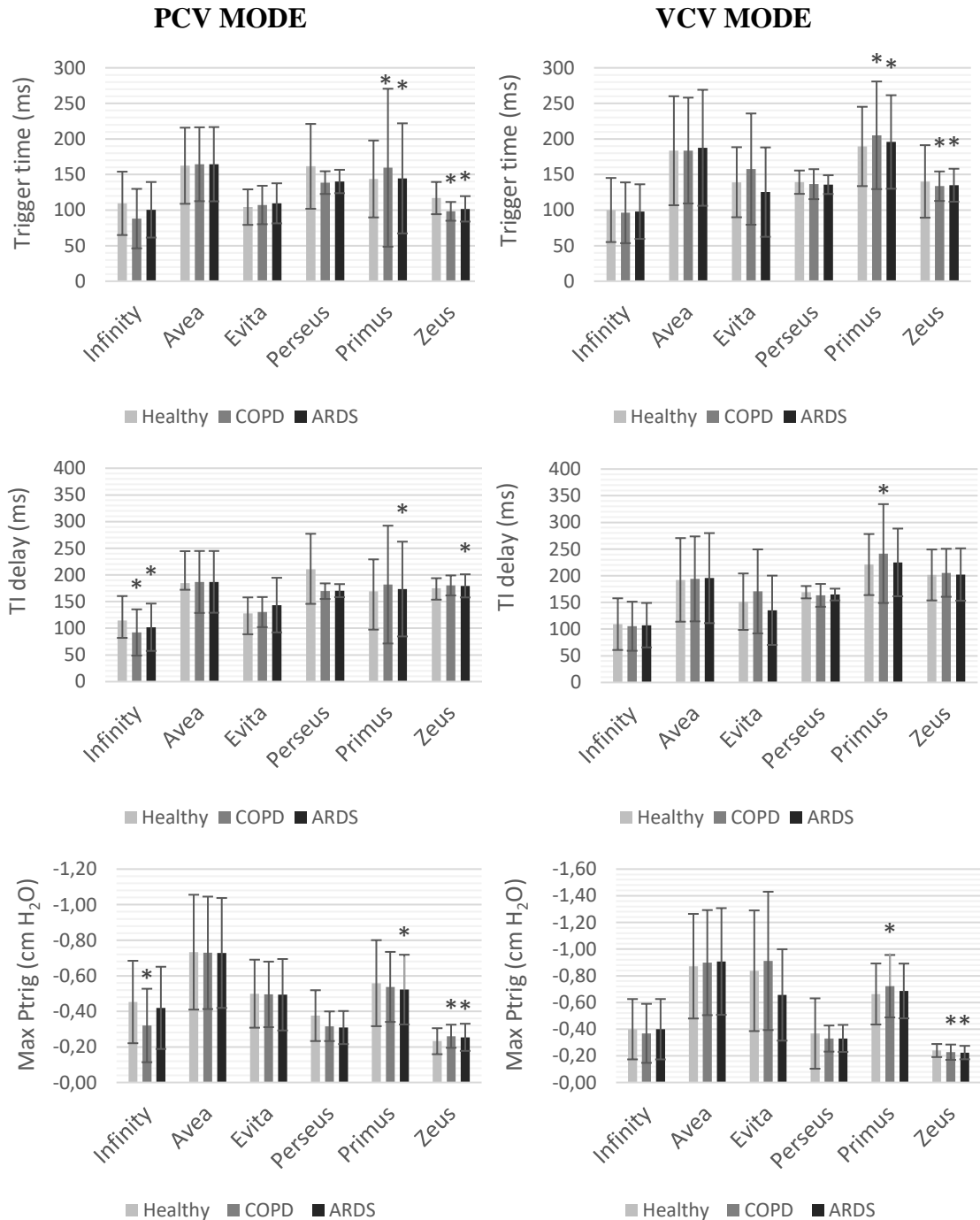


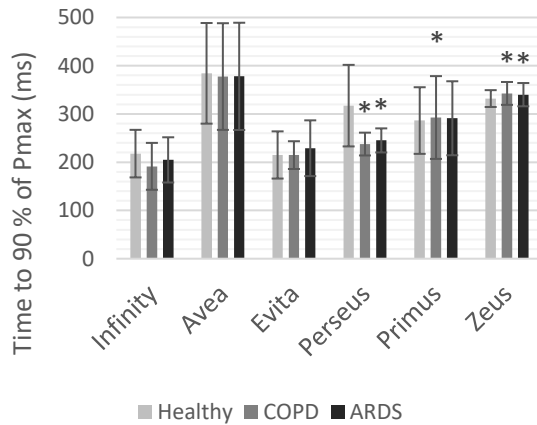
**Figure 15: The comparison of triggering variable for various levels of PEEP in PCV (Figures aligned on the left side) and VCV (Figures aligned on the right side) mode set on the ventilator under the same test conditions.**



### 3.4.3 Impact of various compliance and resistance of the model

Individual triggering variables were calculated as mean  $\pm$  SD in the Matlab Software for all settings including healthy, COPD or ARDS lung model for PCV and VCV mode (Figure 16). The ‘\*’ symbol indicates significant differences compared to the healthy model lung setting.

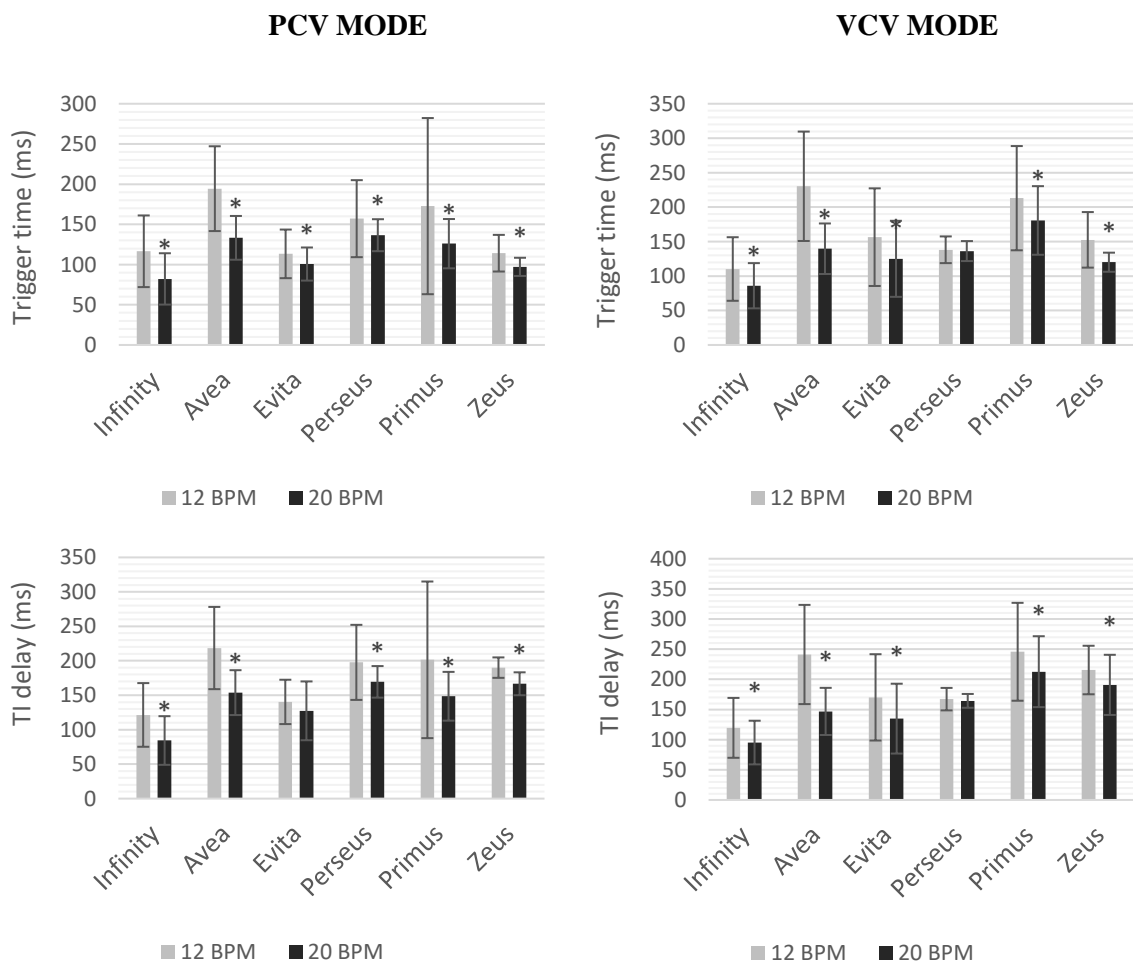


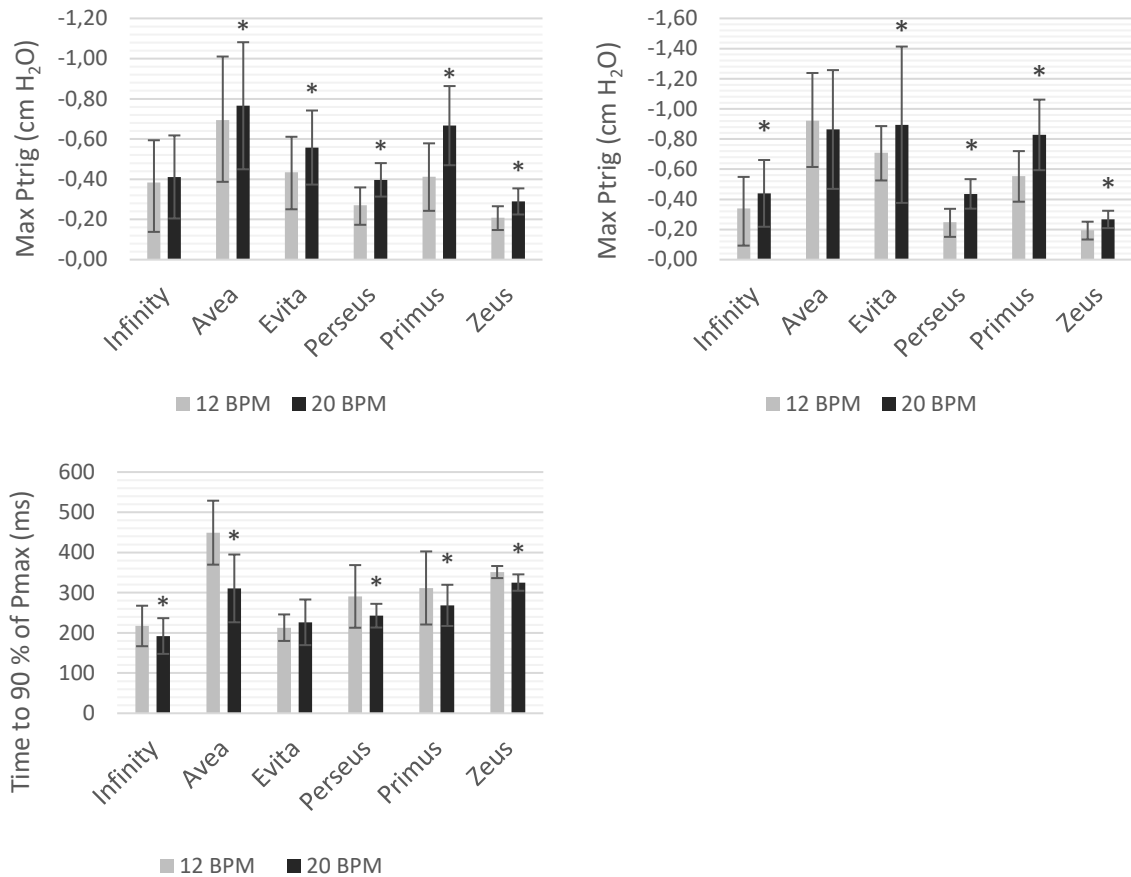


**Figure 16:** The comparison of triggering variables for Healthy, COPD and ARDS lung model setting in PCV (Figures aligned on the left side) and VCV (Figures aligned on the right side) mode measured under the same test conditions.

### 3.4.4 Impact of respiratory rate

Individual triggering variables were calculated as mean  $\pm$  SD in the Matlab Software for all settings including 12 BPM and 20 BPM in PCV and VCV mode (Figure 17). The ‘\*’ symbol indicates significant differences compared to 12 BPM.

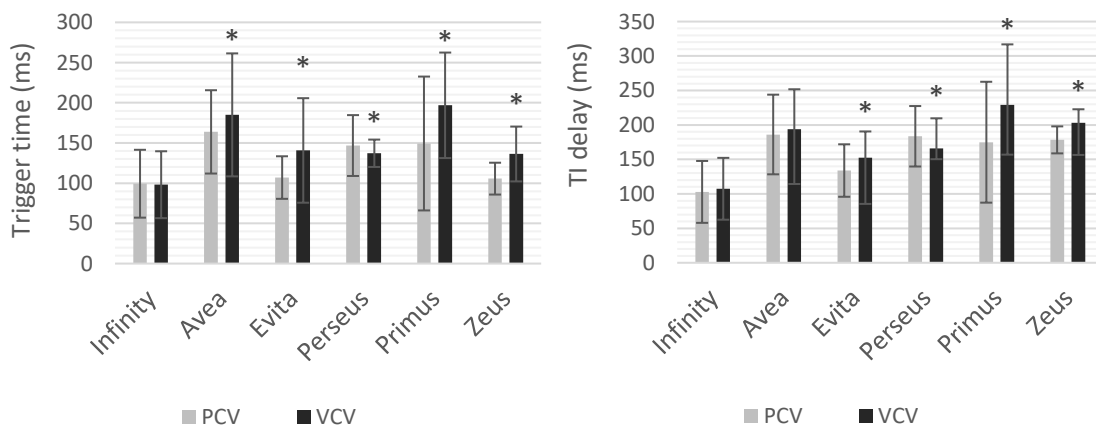


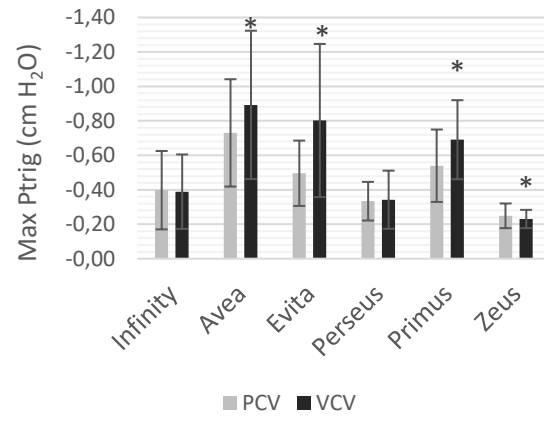


**Figure 17: The comparison of triggering variables for 12 and 20 BPM in PCV (Figures aligned on the left side) and VCV (Figures aligned on the right side) mode measured under the same test conditions.**

### 3.4.5 Impact of ventilation mode

Individual triggering variables were calculated as mean  $\pm$  SD in the Matlab software for all the combinations set in PCV and VCV mode (Figure 18). The ‘\*’ symbol indicates significant differences compared to PCV mode.





**Figure 18: The comparison of triggering variables for PCV mode and VCV mode selected on the ventilator and measured under the same test conditions.**

### 3.5 Overall triggering performance of the ventilators

To define the overall triggering performance, individual variables were calculated as mean  $\pm$  SD for all set combinations (which means all ventilator and lung model settings) in PCV and VCV mode (Table 10). All data was subjected to the normality test. ANOVA analysis with additional Bonferroni correction was used to determine significant differences for multiple comparisons of the variables.

**Table 10: The overall triggering performance of the ventilators during PCV and VCV mode.**

Mode	Ventilator	T <sub>1</sub> delay (ms)	T <sub>trig</sub> (ms)	Max Ptrig (cm H <sub>2</sub> O)	Insp T90 (ms)
PCV	Avea	186,14 $\pm$ 57,78 <sup>PRZ</sup>	163,80 $\pm$ 51,81 <sup>R</sup>	-0,73 $\pm$ 0,31 <sup>EIPRZ</sup>	379,92 $\pm$ 107,21
	Evita	133,85 $\pm$ 38,08	106,98 $\pm$ 26,46 <sup>IZ</sup>	-0,50 $\pm$ 0,19 <sup>AIPRZ</sup>	219,59 $\pm$ 46,58 <sup>I</sup>
	Infinity	102,86 $\pm$ 44,89	99,33 $\pm$ 42,19 <sup>EZ</sup>	-0,40 $\pm$ 0,23 <sup>AEPRZ</sup>	204,69 $\pm$ 48,81 <sup>E</sup>
	Perseus	183,54 $\pm$ 43,85 <sup>ARZ</sup>	146,80 $\pm$ 37,85 <sup>AR</sup>	-0,33 $\pm$ 0,11 <sup>AEIRZ</sup>	266,72 $\pm$ 63,27 <sup>R</sup>
	Primus	183,28 $\pm$ 121,35 <sup>APZ</sup>	152,11 $\pm$ 93,24 <sup>AP</sup>	-0,54 $\pm$ 0,21 <sup>AEIPZ</sup>	286,05 $\pm$ 89,51 <sup>P</sup>
	Zeus	178,33 $\pm$ 19,59 <sup>AR</sup>	105,64 $\pm$ 19,82 <sup>EI</sup>	-0,25 $\pm$ 0,07 <sup>AEIPR</sup>	338,20 $\pm$ 22,13
VCV	Avea	193,99 $\pm$ 79,70 <sup>PRZ</sup>	184,94 $\pm$ 76,49 <sup>R</sup>	-0,89 $\pm$ 0,43 <sup>EIPRZ</sup>	NA
	Evita	152,47 $\pm$ 67,03 <sup>R</sup>	140,71 $\pm$ 64,98 <sup>RZ</sup>	-0,80 $\pm$ 0,44 <sup>AIPRZ</sup>	NA
	Infinity	107,36 $\pm$ 44,86	98,09 $\pm$ 41,58 <sup>Z</sup>	-0,39 $\pm$ 0,22 <sup>AEPRZ</sup>	NA
	Perseus	165,74 $\pm$ 15,42 <sup>AEZ</sup>	137,19 $\pm$ 17,01 <sup>EZ</sup>	-0,34 $\pm$ 0,17 <sup>AEIRZ</sup>	NA
	Primus	233,37 $\pm$ 89,82 <sup>AZ</sup>	196,82 $\pm$ 65,61 <sup>A</sup>	-0,69 $\pm$ 0,23 <sup>AEIPZ</sup>	NA
	Zeus	203,13 $\pm$ 46,66 <sup>APR</sup>	136,30 $\pm$ 34,11 <sup>EIR</sup>	-0,23 $\pm$ 0,05 <sup>AEIPR</sup>	NA

<sup>A</sup>Triggering variable is not significantly different from Avea

<sup>E</sup>Triggering variable is not significantly different from Evita

<sup>I</sup>Triggering variable is not significantly different from Infinity XL

<sup>P</sup>Triggering variable is not significantly different from Perseus

<sup>R</sup>Triggering variable is not significantly different from Primus

<sup>Z</sup>Triggering variable is not significantly different from Zeus

NA means not applicable for the VCV mode

## 4 Discussion

The main findings of this study can be summarized as follows:

- There were observed significant differences in the performance between the group of anesthesia and ICU ventilators, but also among the individual groups of the ventilators
- The performance of the newest anesthesia ventilators was closer to the results measured with ICU ventilators in comparison with older generation of anesthesia ventilators
- The newest anesthesia ventilators showed a better ventilation performance than an ICU ventilator of a different manufacturer
- Two of the tested anesthesia ventilators had difficulties to keep the zero PEEP level
- The set peak inspiratory pressure during PCV is more precise for ICU ventilators, the set tidal volume during VCV is in most of the cases comparable for both groups of the ventilators
- Various levels of peak inspiratory pressure, tidal volume, PEEP, diverse compliance and resistance of the lung model, respiratory rate and diverse ventilation modes significantly affected the variables with of some of the ventilators
- The triggering variables reached higher values with the VCV mode compared to PCV mode
- Avea and Primus ventilators registered the largest instability in the triggering capabilities
- The assisted ventilation modes might require more frequent supervision from the medical practitioners when used with the patient

### **OVERALL TRIGGERING PERFORMANCE OF THE VENTILATORS**

The newest ICU ventilator, Infinity XL, showed the fastest triggering performance in both PCV and VCV mode. From the group of anesthesia ventilators, the triggering response was best performed by Zeus in PCV and Perseus in VCV. Avea was the ICU ventilator with the longest triggering response, and the anesthesia ventilators showed faster triggering capabilities in PCV mode. Primus had the longest triggering performance in VCV mode.

To sum it up, newer ICU ventilators, such as Infinity XL and Evita, reported the lowest values of the triggering variables. There is a visible improvement in the triggering capabilities among the generation of anesthesia ventilators as the newer machines, including Perseus and Zeus, responded to the patient's inspiratory effort more rapidly than Primus, which was the oldest machine from the anesthesia group. Even though, there were observed significant differences among the overall triggering performance of ICU and anesthesia machines, the technological progress carried out by one manufacturer is noticeable. Avea performed differently than the other ICU ventilators. This might be due

to different technological and breathing circuit constitution offered by other manufacturer or the incapability to respond at a comparable speed like other ICU ventilators that were included in the study.

The triggering variables demonstrated a similar trend and values for all ventilators under various tested ventilator and model settings in PCV and VCV mode. The triggering variables reached higher values in use with VCV mode compared to PCV. The largest deflection in evaluated variables was present with Avea and Primus ventilator.

During PCV mode, the  $T_{trig}$  variable reached over 150 ms with Primus and Avea, below 150 ms with Evita, Perseus and Zeus and less than 100 ms with Infinity. The  $T_I$  delay over 200 ms was noticeable for Avea, Primus, Perseus and Zeus and below 150 ms for Evita and Infinity. The  $P_{min}$  pressure was least for Zeus ventilator, meaning  $-0.25$  cm H<sub>2</sub>O only, around  $-0.5$  cm H<sub>2</sub>O for Evita, Infinity and Perseus and over  $-0.5$  cm H<sub>2</sub>O for Avea and Primus. The T90 parameter diminished with ICU ventilators to roughly 200 ms, except for Avea, and grew among the group of anesthesia machines to around 300 ms.

The trends for individual triggering parameters in VCV were as follows:  $T_{trig}$  variable attained over 180 ms for Avea and Primus, below 140 ms for Evita, Perseus and Zeus and below 100 ms for Infinity. The  $T_I$  delay moved around 200 ms with Avea, Primus and Zeus, roughly 160 ms with Evita and Perseus and slightly over 100 ms with Infinity. Zeus registered the lowest  $P_{min}$  drop around  $-0.20$  cm H<sub>2</sub>O, Infinity and Perseus slightly more, over  $-0.30$  cm H<sub>2</sub>O, and Avea, Evita and Primus need more than  $-0.70$  cm H<sub>2</sub>O to trigger.

Although the triggering performance between the ventilators was determined as significant, it is crucial to realize that the mutual discrepancies are raging in the magnitude of milliseconds and in tenths of water column units. Therefore, it is questionable if such small variances might have an impact on the patient's comfort or not. The fact that no standardized values exists for the comparison of the ventilator's performance makes this decision-making process even more difficult.

## **THE ACCURACY IN PRESSURE AND VOLUME DELIVERY**

The set peak inspiratory pressure was more accurately delivered by ICU ventilators compared to anesthesia. The most precise figures were observed with Avea and Infinity XL ventilator. Conversely, Perseus delivered higher pressure values in all peak inspiratory pressures and significantly differed from the ventilators (except from Evita on zero PEEP). Primus ventilator delivered lower peak inspiratory pressure than demanded and its results significantly differed from all other ventilators. The outcomes measured with Primus showed a large variance.

The volume delivery at lower tidal volumes (200 mL) was comparable for most of the ventilators. More significant differences were observed at the normal and higher tidal

volumes (400 and 600 mL). Infinity XL performed with the most accurate volume delivery, whereas Evita and Zeus demonstrated the least accurate results.

### **THE ACCURACY IN PEEP LEVEL DELIVERY**

The level of maintained zero PEEP was comparable for the whole group of the ventilators, except for Perseus and Zeus. The Perseus and Zeus ventilators kept higher PEEP at zero level PEEP setting compared to the other machines. The difference above zero PEEP with Zeus ventilator reached up to 3.01 cm H<sub>2</sub>O in PCV and 2.58 cm H<sub>2</sub>O in VCV. The Zeus ventilator performed comparably to ICU (Evita, Infinity) on higher PEEP levels. The anesthesia ventilators, Perseus and Primus, showed mutually comparable results on higher PEEP. Overall, the most precise results were measured with Infinity XL, with also very small deflection, and the least accurate with Avea in both PCV and VCV mode. The PEEP level maintained by Avea significantly differed from the rest of the group on all PEEP levels except for zero PEEP. The selected ventilation mode had no impact on accuracy of delivered PEEP.

### **IMPACT OF VARIOUS PEAK INSPIRATORY PRESSURES AND TIDAL VOLUMES**

Various levels of peak inspiratory pressures significantly affected all of the triggering variable on the Primus and Zeus ventilator and the T<sub>I</sub> delay variable with Perseus. The triggering variables slightly increased with Zeus on higher peak inspiratory pressures. These minor changes in the triggering variables were denoted as significant due to the very small variance with individual triggering variables measured on the Zeus ventilator. To the contrary, the Primus reported a large variance for most of the measured variables. For the rest of the ventilators the triggering variables were comparable at all peak inspiratory pressures.

Various tidal volumes affected all the triggering parameters for Primus and Zeus, and the T<sub>trig</sub> variable for Evita. The triggering capability of Zeus deteriorated as the tidal volume increased. Both in PCV and VCV mode, the triggering variables of the Primus ventilator reached higher values with smaller inspiratory peak pressures or tidal volumes.

### **IMPACT OF VARIOUS PEEP LEVELS**

Different levels of set PEEP had a significant impact on the triggering variables in PCV and VCV mode, mainly with Avea, Primus and Evita. There were major differences between the variables obtained during zero PEEP and on the other levels. Avea reported significantly faster triggering capabilities on zero PEEP than on any other PEEP level for all variables. The same behavior reported Primus with all of the variables and Zeus with P<sub>min</sub>, although the differences were not so visible as with Avea. Diverse effect counted for Evita and Perseus, where triggering capabilities deteriorated on zero PEEP and enhanced on other PEEP levels.



Most of the ventilators had a smaller  $P_{\min}$  drop during zero PEEP, which resulted in smaller Time to  $P_{\min}$  and  $T_I$  delay on zero PEEP. This was observed with all ventilators, except for Evita and Perseus. It might be more facile for those ventilators to detect changes in the circuit pressure when a model simulates inhalation on zero PEEP, as there are less fluctuations in the circuit pressure. The different behavior with Evita and Perseus might be explained by the fact that with zero PEEP, the end of the expiration does not have to be electronically controlled, and the process have a spontaneous course. It means that the pressure changes in the circuit are not measured during that moment and it might thus prolong the time to react to the patient's inspiratory effort. These nuances might be also caused by various circuit constitution and implemented technologies.

### **IMPACT OF VARIOUS COMPLIANCE AND RESISTANCE OF THE MODEL**

The various lung compliance had a significant impact on the triggering response of the Primus and Zeus ventilator for most of the evaluated triggering parameters. The  $T_{90}$  variable for Perseus, and the  $P_{\min}$  and  $T_{90}$  variable for Infinity, significantly differed under various setting of the lung model's compliance and resistance.

Different patterns in triggering variables were observed among the ventilators if the model's compliance and resistance was altered. Higher compliance should lead to longer response of the ventilator (mainly the  $T_{90}$  variable should be delayed), as more compliant system can be less rapidly decompressed, and the decrease in resistance should delay the ventilator's response [28]. Increased ventilator response to COPD model was noticeable with some of the ventilators, especially in PCV mode. The  $T_I$  delay and  $T_{90}$  variables raised with the COPD model (high compliance and high resistance) with Evita, Primus, and Zeus. Therefore, these ventilators were more susceptible to enlarged compliance. Infinity and Primus had these variables the highest with normal patient model setting, which possesses with low resistance and normal compliance. Avea performed independently on the model setting. Theoretically, the ARDS setting should result in the fastest response of the ventilator as the resistance is high and compliance low, however, the variables with ARDS setting in most of the cases were equal to those with normal model. This might imply that the lower resistance and higher compliance (healthy model) have a similar effect as higher resistance and lower compliance (ARDS model) [4].

### **IMPACT OF VARIOUS RESPIRATORY RATE**

The different respiratory rate setting impacted all evaluated variables among the ventilators. The time variables  $T_{\text{trig}}$ ,  $T_I$  delay and  $T_{90}$  were significantly higher when the ventilator and the model were set to respiratory rate of 12 breaths. These variables dropped with the respiratory rate of 20 breaths per minute. Contrarywise, the  $P_{\min}$  more significantly dropped with 20 BPM than with 12 BPM. Based on such observations, it can be assumed that the pressure drop is more sensitive to lower frequencies, thus less

patient's effort is required to start the triggering process, but the time response and pressurization is prolonged.

### **IMPACT OF VENTILATION MODE**

The overall variables resulted in lower figures during PCV mode than in VCV mode in all included ventilators apart from Infinity which performed equally during both modes. The results with VCV showed greater inconsistency than with PCV. The difference in  $T_{I\text{delay}}$  variable might have occurred due to variable-flow pattern typical for PCV modes, unlike the VCV mode that operates with fixed-flow pattern only. As a result, the pressure can achieve the baseline more quickly [4]. The  $T_{\text{trig}}$  and  $P_{\text{min}}$  variables also reached significantly lower values with PCV, therefore, the synchronized PCV could represent a more gentle mode of the mechanical ventilation.

### **THE PRESSURIZATION PHASE OF THE VENTILATORS**

The  $T_{90}$  parameter describes the features of the ventilator during pressurization phase. The ICU ventilators are capable of fast flow delivery thanks to the use of electrically-driven pistons or turbines for creating the inspiratory pressure flow. Anesthesia ventilators involved in this study used modern piston or turbine drive to reduce the drawbacks of slower gas flow delivery with anesthesia machines. Despite these advancements, the differences were still evident. The differences were described by the flow curves during the pressurization phase (Figure 12). The decelerating part of the flow curve for the ventilators having higher  $T_{90}$  during PCV mode (Avea, Primus, Zeus) had a more parabolic shape, which resulted in a prolonged time to achieve the maximum pressure support. The flow curves during pressurization for Evita, Infinity, and Perseus had almost a vertical course. Perseus had the  $T_{90}$  variable closest to the ones of the ICU ventilators. Further studies might be conducted to test the flow limitation of the anesthesia machines at high airway pressures [3, 27, 28].

### **THE USE OF SIMV AND ACV MODE DURING VENTILATION**

The purpose of synchronized and assisted ventilation modes with anesthesia ventilators have an unspecified use in daily practice and remains marginalized by the medical practitioners. However, a few studies have proven the possible advantages of its availability with anesthesia machines [3, 4]. Based on the outcomes of this study, the newer anesthesia machines have the triggering capabilities closer to the ones measured with ICU ventilators. Despite this fact, it is essential to also assess the capability of the ventilators to synchronize with the patient's inspiratory effort. There was a large difference observed between the group of ICU and mainly older anesthesia ventilators.

When the ICU ventilators were connected to the lung model with normal respiratory rate, they usually managed to adapt to the model's respiratory rate within few seconds and readjusted the pressure or volume delivery according to the inspiratory efforts. The ICU

ventilators started to mistrigger at a higher respiratory rate as they were not able to synchronize with the inspiratory efforts. In this case, the ventilators were delivering the ventilation support without any synchronization with the model. Therefore, the respiratory rate on the ventilator had to be manually reduced to prolong the period of time between individual breaths, so the inspiratory effort of the model could be sensed and the period of ventilator's delivery recalculated from the triggering point. For example, the Avea ventilator showed unsatisfactory triggering performance, although, its capability to synchronize with the model was instantaneous.

The Perseus ventilator needed respiratory rate readjustments on higher respiratory rates only, unlike Zeus and Primus. Overall, Primus had considerable difficulties to adequately synchronize in most of the tested combinations. The same discrepancies were also valid for Zeus ventilator which had, on the contrary, fast triggering performance. The synchronization was well-performed at zero PEEP levels and significantly worsened on higher PEEP levels and higher respiratory rate.

Consequently, the synchronized and assisted ventilation modes might require more caution. Unsynchronized ventilation delivery with spontaneous patient breathing might harm the weaning process from the ventilator and possibly result in barotrauma injury cause by lung hyperinflation [5].

## **COMPARISON TO OTHER STUDIES**

Some findings of this study are consistent with the findings of different studies conducted in this fields of interest. One study (*Performance Characteristics of Five New Anesthesia and Four Intensive Care Ventilators in Pressure Support Mode, 2006*) proves that the VA/C mode results in greater variances across the evaluated triggering variables within individual ventilators, whereas, there were no significant differences observed during PA/C mode. The same study also claims that the generation of ICU ventilators, including Evita XL, has in general higher capabilities of fast response and better pressurization compared to the previous generation. The use of PEEP modifies the quality of some of the evaluated variables among the ventilators, including zero PEEP level, which causes the largest disparities during our study [4].

On the contrary, other study (*Performance of Current Intensive Care Unit Ventilators, 2011*) shows that the PEEP has no significant effect on any of the evaluated variables (zero PEEP wasn't included). The study also suggests that the functionality of anesthesia ventilators operating in PSV mode is comparable to older-generation of ICU ventilators, however, still not comparable to the performance of the newest ICU machines [28].

The variables within all the studies were markedly affected by diverse lung mechanics. In general, decreasing resistance increases the ventilator's response and the same impact is present with increasing compliance. This resulted in a prolonged triggering

performance during COPD model simulation. The variables during ARDS simulation achieved comparable or smaller values than with normal lung model. There were no important differences observed in our study, however, the trend in variables was similar to the findings of these studies [4, 28, 29].

## **LIMITATIONS**

The primary limitation of this study is that the results were obtained by the use of lung simulator instead of real patients. However, the lung model ensures that all ventilators are subjected to equal test conditions and that it maintains linear compliance and resistance during individual breaths. Another limitation underlays in the diverse anatomical physiological features of the real lungs compared to the lung model simulator. The model was also simplified to a one-lung model only. In the end, the inspiratory pressure curve registered by the ventilator during the triggering might have a distinct course during simulation and during the connection with a real patient, and it is possible that the response of the ventilator may vary when ventilating a real patient.

Another drawback of the study represents the number of selected machines which was limited to the accessibility of the ventilators used at the medical department, where the study was conducted, and also to the availability of synchronized modes on these ventilators.

## **5 Conclusion**

There were significant differences proven in the accuracy of peak pressure, tidal volume and PEEP level delivery, as well as in the overall triggering performance between the group of ICU and anesthesia ventilators, but also inside the individual groups of the ventilators. Two anesthesia ventilators had difficulties to maintain zero PEEP compared to ICU ventilators. Substantial differences occurred among the older anesthesia machines and newer ICU ventilators and among the ventilators of a different make. A technological development among the group of ventilators from the same manufacturer is noticeable as the newest anesthesia machines narrow down the performance gap between anesthesia and ICU ventilators. The newer anesthesia machines from the same manufacturer demonstrated better results than the ICU ventilator from a different manufacturer. Despite defining the differences as statistically important, it is necessary to further determine the clinical relevance of such disparities among the performance of the ventilators. All the tested lung model settings and the ventilator settings modified the triggering variables of some of the evaluated ventilators.

## 6 References

- [1] MARCHESE, A. D., D. SULEMANJI, D. CHIPMAN, J. VILLAR a R. M. KACMAREK. 2011. Performance of Current Intensive Care Unit Ventilators During Pressure and Volume Ventilation. *Respiratory Care* [online]. 56(7): 928-940 [cit. 2018-05-18]. DOI: 10.4187/respcare.00981. ISSN 0020-1324. Available at: <http://rc.rcjournal.com/cgi/doi/10.4187/respcare.00981>
- [2] JAIN, RajnishK a Srinivasan SWAMINATHAN. Anaesthesia ventilators. *Indian Journal of Anaesthesia* [online]. 2013, 57(5), 525- [cit. 2018-05-18]. DOI: 10.4103/0019-5049.120150. ISSN 0019-5049. Available at: <http://www.ijaweb.org/text.asp?2013/57/5/525/120150>.
- [3] TUNG, Avery. New Developments in Anesthesia Ventilators. *Advances in Anesthesia* [online]. 2005, 23, 173-193 [cit. 2018-05-18]. DOI: 10.1016/j.aan.2005.07.002. ISSN 07376146. Available at: <http://linkinghub.elsevier.com/retrieve/pii/S0737614605000109>
- [4] Samir Jaber, M.D., Ph.D.;. 2006. Performance Characteristics of Five New Anesthesia Ventilators and Four Intensive Care Ventilators in Pressure-support Mode: A Comparative Bench Study [online]. *Anesthesiology* 11 2006, Vol.105,,: 944-952 [cit. 2018-05-18]. Available at: <http://anesthesiology.pubs.asahq.org/article.aspx?articleid=1922826>
- [5] HAMED, Hala M.F., Hisham G. IBRAHIM, Yehia H. KHATER a Ezzat S. AZIZ. Ventilation and ventilators in the ICU: What every intensivist must know. *Current Anaesthesia & Critical Care* [online]. 2006, 17(1-2), 77-83 [cit. 2018-05-18]. DOI: 10.1016/j.cacc.2006.07.008. ISSN 09537112. Available at: <http://linkinghub.elsevier.com/retrieve/pii/S0953711206000858>.
- [6] Overview of Mechanical Ventilation [online]. Bhakti K. Patel, MD, Assistant Professor, Department of Medicine, Section of Pulmonary/Critical Care, University of Chicago [cit. 2018-05-18]. Available at: <https://www.msmanuals.com/professional/critical-care-medicine/respiratory-failure-and-mechanical-ventilation/overview-of-mechanical-ventilation#v926982>
- [7] Campbell RS1 a Davis BR. Pressure-controlled versus volume-controlled ventilation: does it matter?. *Respir Care* [online]. 2002 Apr;47(4):416-24,,: 424-6 [cit. 2018-05-18]. Available at: <https://www.ncbi.nlm.nih.gov/pubmed/1192961>
- [8] COPD (Chronic Obstructive Pulmonary Disease) Symptoms, Causes, Stages and Life Expectancy [online]. *MedicineNe* [cit. 2018-05-18]. Available at:

[https://www.medicinenet.com/copd\\_chronic\\_obstructive\\_pulmonary\\_disease/article.htm#which\\_types\\_of\\_doctors\\_treat\\_copd](https://www.medicinenet.com/copd_chronic_obstructive_pulmonary_disease/article.htm#which_types_of_doctors_treat_copd)

- [9] ARDS [online]. Mayo Foundation for Medical Education and Research [cit. 2018-05-18]. Available at: <https://www.mayoclinic.org/diseases-conditions/ards/symptoms-causes/syc-20355576?p=1>
- [10] PACHL, Jan a Karel ROUBÍK. Základy anesteziologie a resuscitační péče dospělých i dětí. Praha: Karolinum, 2003. Učební texty Univerzity Karlovy v Praze. ISBN 80-246-0479-5.
- [11] DOSTÁL, Pavel. Základy umělé plicní ventilace. 2., rozš. vyd. Praha: Maxdorf, c2005. Jessenius. ISBN 80-7345-059-3..
- [12] TOL, Govind a James PALMER. Principles of mechanical ventilation. *Anaesthesia & Intensive Care Medicine* [online]. 2010, 11(4), 125-128 [cit. 2018-05-18]. DOI: 10.1016/j.mpaic.2010.01.002. ISSN 14720299. Available at: <http://linkinghub.elsevier.com/retrieve/pii/S147202991000>.
- [13] TOL, Govind a James PALMER. Principles of mechanical ventilation. *Anaesthesia & Intensive Care Medicine* [online]. 2010, 11(4), 125-128 [cit. 2018-05-18]. DOI: 10.1016/j.mpaic.2010.01.002. ISSN 14720299. Available at: <http://linkinghub.elsevier.com/retrieve/pii/S1472029910000214>
- [14] GENTILE, M. A. Cycling of the Mechanical Ventilator Breath. *Respiratory Care* [online]. 2011, 56(1), 52-60 [cit. 2018-05-18]. DOI: 10.4187/respcare.01088. ISSN 0020-1324. Available at: <http://rc.rcjournal.com/cgi/doi/10.4187/respcare.01088>
- [15] KARCZ, Marcin, Alisa VITKUS, Peter J. PAPADAKOS, David SCHWAIBERGER a Burkhard LACHMANN. State-of-the-Art Mechanical Ventilation. *Journal of Cardiothoracic and Vascular Anesthesia* [online]. 2012, 26(3), 486-506 [cit. 2018-05-18]. DOI: 10.1053/j.jvca.2011.03.010. ISSN 10530770. Available at: <http://linkinghub.elsevier.com/retrieve/pii/S1053077011001364>
- [16] David J Pierson MD. 2008. A Primer on Mechanical Ventilation. *Courses.washington.edu* [online]. Washington: University of Washington [cit. 2018-05-18]. Available at: [https://courses.washington.edu/med610/mechanicalventilation/mv\\_primer.html](https://courses.washington.edu/med610/mechanicalventilation/mv_primer.html)
- [17] Mechanical Ventilation [online]. 2018. East Tennessee State University: Medscape [cit. 2018-05-18]. Available at: <https://emedicine.medscape.com/article/304068-overview#a3>.

- [18] HAMED, Hala M.F., Hisham G. IBRAHIM, Yehia H. KHATER a Ezzat S. AZIZ. Ventilation and ventilators in the ICU: What every intensivist must know. *Current Anaesthesia & Critical Care* [online]. 2006, 17(1-2), 77-83 [cit. 2018-05-18]. DOI: 10.1016/j.cacc.2006.07.008. ISSN 09537112. Available at: <http://linkinghub.elsevier.com/retrieve/pii/S0953711206000858>.
- [19] Chatburn RL. Classification of ventilator modes: update and proposal for implementation. *Respi Care* [online]. 2007 Mar;52(3):301-23. [cit. 2018-05-18]. Available at: <https://www.ncbi.nlm.nih.gov/pubmed/17328828>.
- [20] SALYER, Steven W. Pulmonary Emergencies. *Essential Emergency Medicine* [online]. Elsevier, 2007, 2007, s. 844-913 [cit. 2018-05-18]. DOI: 10.1016/B978-141602971-7.10015-7. ISBN 9781416029717. Available at: <http://linkinghub.elsevier.com/retrieve/pii/B9781416029717100157>
- [21] GATTINONI, Luciano, Francesca COLLINO, Giorgia MAIOLO, Francesca RAPETTI, Federica ROMITTI, Tommaso TONETTI, Francesco VASQUES a Michael QUINTEL. Positive end-expiratory pressure: how to set it at the individual level. *Annals of Translational Medicine* [online]. 2017, 5(14), 288-288 [cit. 2018-05-18]. DOI: 10.21037/atm.2017.06.64. ISSN 23055839. Available at: <http://atm.amegroups.com/article/view/15614/15780>
- [22] MILLER, Nichole. Set the stage for ventilator settings. *Nursing Made Incredibly Easy!* [online]. 2013, 11(3), 44-52 [cit. 2018-05-18]. DOI: 10.1097/01.NME.0000428429.60123.f7. ISSN 1544-5186. Available at: <http://content.wkhealth.com/linkback/openurl?sid=WKPTLP:landingpage&an=00152258-201305000-00009>
- [23] Anesthesia Delivery System [online]. *Access Anesthesiology* [cit. 2018-05-18]. Available at: <https://accessanesthesiology.mhmedical.com/content.aspx?bookid=490&ionid=40114726&jumpsectionID=40122464>.
- [24] Decision Making in Anesthesiology [online]. 2007. Elsevier [cit. 2018-05-18]. Available at: <https://www.sciencedirect.com/science/book/9780323039383>
- [25] DIVATIA, JigeeshuV, VijayaP PATIL a MadhaviG SHETMAHAJAN. The modern integrated anaesthesia workstation. *Indian Journal of Anaesthesia* [online]. 2013, 57(5), 446- [cit. 2018-05-18]. DOI: 10.4103/0019-5049.120139. ISSN 0019-5049. Available at: <http://www.ijaweb.org/text.asp?2013/57/5/446/120139>
- [26] TUNG, Avery, Melinda L. DRUM a Sherwin MORGAN. Effect of inspiratory time on tidal volume delivery in anesthesia and intensive care unit ventilators operating in pressure control mode. *Journal of Clinical Anesthesia* [online]. 2005, 17(1), 8-15 [cit. 2018-05-18].



- DOI: 10.1016/j.jclinane.2004.02.005. ISSN 09528180. Available at: <http://linkinghub.elsevier.com/retrieve/pii/S0952818004002016>
- [27] The Anesthesia Ventilator [online]. 2010. Elsevier [cit. 2018-05-18]. Available at: [https://www.draeger.com/Library/Content/9049447\\_the\\_anesthesia Ventilator\\_8seitig\\_en\\_101209\\_fin.pdf](https://www.draeger.com/Library/Content/9049447_the_anesthesia Ventilator_8seitig_en_101209_fin.pdf)
- [28] MARCHESE, A. D., D. SULEMANJI, D. CHIPMAN, J. VILLAR a R. M. KACMAREK. Performance of Current Intensive Care Unit Ventilators During Pressure and Volume Ventilation. *Respiratory Care* [online]. 2011, 56(7), 928-940 [cit. 2018-05-18]. DOI: 10.4187/respcare.00981. ISSN 0020-1324. Available at: <http://rc.rcjournal.com/cgi/doi/10.4187/respcare.00981>
- [29] FERREIRA, Juliana C., Daniel W. CHIPMAN a Robert M. KACMAREK. Trigger performance of mid-level ICU mechanical ventilators during assisted ventilation: a bench study. *Intensive Care Medicine* [online]. 2008, 34(9), 1669-1675 [cit. 2018-05-18]. DOI: 10.1007/s00134-008-1125-5. ISSN 0342-4642. Available at: <http://link.springer.com/10.1007/s00134-008-1125-5>
- [30] Anaesthesia Breathing Systems [online]. 2017. USyd Lectures [cit. 2018-05-18]. Available at: [http://www.anaesthesia.med.usyd.edu.au/resources/lectures/gas\\_supplies\\_clt/breathingsystems.html](http://www.anaesthesia.med.usyd.edu.au/resources/lectures/gas_supplies_clt/breathingsystems.html)
- [31] Jamaal T. Snell, MD. The Anesthesia Guide: Chapter 48. Breathing Circuits. *Accessanesthesiology.mhmedical.com* [online]. Access Anesthesiology [cit. 2018-05-18]. Available at: <https://accessanesthesiology.mhmedical.com/content.aspx?bookid=572&ionid=42543633>
- [32] KAUL, TejK a Geeta MITTAL. Mapleson's breathing systems. *Indian Journal of Anaesthesia* [online]. 2013, 57(5), 507- [cit. 2018-05-18]. DOI: 10.4103/0019-5049.120148. ISSN 0019-5049. Available at: <http://www.ijaweb.org/text.asp?2013/57/5/507/120148>
- [33] Mapleson Breathing Circuit Made Easy [online]. *Epomedicine* [cit. 2018-05-18]. Available at [https://www.http://epomedicine.com/medical-students/mapleson-breathing-circuit-made-easy/.org/anesthesia\\_delivery\\_systems\\_anesthesia\\_text/](https://www.http://epomedicine.com/medical-students/mapleson-breathing-circuit-made-easy/.org/anesthesia_delivery_systems_anesthesia_text/)
- [34] Mike Wild FRCA. Mapleson Breathing Circuit Made Easy [online]. *Epomedicine* [cit. 2018-05-18]. Available at: [https://www.http://epomedicine.com/medical-students/mapleson-breathing-circuit-made-easy/.org/anesthesia\\_delivery\\_systems\\_anesthesia\\_text/](https://www.http://epomedicine.com/medical-students/mapleson-breathing-circuit-made-easy/.org/anesthesia_delivery_systems_anesthesia_text/). *British Journal of Anesthesia* [online]. 2001(Vol.1, Number 3): 89-92 [cit. 2018-05-18]. Available at: [http://e-safe-anaesthesia.org/e\\_library/12/PEEP\\_and\\_CPAP.pdf](http://e-safe-anaesthesia.org/e_library/12/PEEP_and_CPAP.pdf)

## Appendix A: The protocol of measurement for PCV mode

<b>Healthy model</b> $R_{rs} = 3 \text{ cm H}_2\text{O}\cdot\text{s/L}$ $C_{rs} = 60 \text{ mL/cm H}_2\text{O}$					
RR = 12 BPM					
P = 5 cm H <sub>2</sub> O		P = 10 cm H <sub>2</sub> O		P = 15 cm H <sub>2</sub> O	
PEEP	Record number	PEEP PEEP	Record number	PEEP PEEP	Record number
0 cm H <sub>2</sub> O	1	0 cm H <sub>2</sub> O	5	0 cm H <sub>2</sub> O	9
5 cm H <sub>2</sub> O	2	5 cm H <sub>2</sub> O	6	5 cm H <sub>2</sub> O	10
10 cm H <sub>2</sub> O	3	10 cm H <sub>2</sub> O	7	10 cm H <sub>2</sub> O	11
15 cm H <sub>2</sub> O	4	15 cm H <sub>2</sub> O	8	15 cm H <sub>2</sub> O	12

<b>Healthy model</b> $R_{rs} = 3 \text{ cm H}_2\text{O}\cdot\text{s/L}$ $C_{rs} = 60 \text{ mL/cm H}_2\text{O}$					
RR = 20 BPM					
P = 5 cm H <sub>2</sub> O		P = 10 cm H <sub>2</sub> O		P = 15 cm H <sub>2</sub> O	
PEEP	Record number	PEEP	Record number	PEEP	Record number
0 cm H <sub>2</sub> O	13	0 cm H <sub>2</sub> O	17	0 cm H <sub>2</sub> O	21
5 cm H <sub>2</sub> O	14	5 cm H <sub>2</sub> O	18	5 cm H <sub>2</sub> O	22
10 cm H <sub>2</sub> O	15	10 cm H <sub>2</sub> O	19	10 cm H <sub>2</sub> O	23
15 cm H <sub>2</sub> O	16	15 cm H <sub>2</sub> O	20	15 cm H <sub>2</sub> O	24

<b>ARDS model</b> $R_{rs} = 7.5 \text{ cm H}_2\text{O}\cdot\text{s/L}$ $C_{rs} = 30 \text{ mL/cm H}_2\text{O}$					
RR = 12 BPM					
P = 5 cm H <sub>2</sub> O		P = 10 cm H <sub>2</sub> O		P = 15 cm H <sub>2</sub> O	
PEEP	Record number	PEEP	Record number	PEEP	Record number
0 cm H <sub>2</sub> O	25	0 cm H <sub>2</sub> O	29	0 cm H <sub>2</sub> O	33
5 cm H <sub>2</sub> O	26	5 cm H <sub>2</sub> O	30	5 cm H <sub>2</sub> O	34
10 cm H <sub>2</sub> O	27	10 cm H <sub>2</sub> O	31	10 cm H <sub>2</sub> O	35
15 cm H <sub>2</sub> O	28	15 cm H <sub>2</sub> O	32	15 cm H <sub>2</sub> O	36

<b>ARDS model</b> $R_{rs} = 7.5 \text{ cm H}_2\text{O}\cdot\text{s/L}$ $C_{rs} = 30 \text{ mL/cm H}_2\text{O}$					
RR = 20 BPM					
P = 5 cm H <sub>2</sub> O		P = 10 cm H <sub>2</sub> O		P = 15 cm H <sub>2</sub> O	
PEEP	Record number	PEEP	Record number	PEEP	Record number
0 cm H <sub>2</sub> O	37	0 cm H <sub>2</sub> O	41	0 cm H <sub>2</sub> O	45
5 cm H <sub>2</sub> O	38	5 cm H <sub>2</sub> O	42	5 cm H <sub>2</sub> O	46
10 cm H <sub>2</sub> O	39	10 cm H <sub>2</sub> O	43	10 cm H <sub>2</sub> O	47
15 cm H <sub>2</sub> O	40	15 cm H <sub>2</sub> O	44	15 cm H <sub>2</sub> O	48

<b>COPD model</b> $R_{rs} = 10 \text{ cm H}_2\text{O}\cdot\text{s/L}$ $C_{rs} = 80 \text{ mL/cm H}_2\text{O}$					
RR = 12 BPM					
P = 5 cm H <sub>2</sub> O		P = 10 cm H <sub>2</sub> O		P = 15 cm H <sub>2</sub> O	
PEEP	Record number	PEEP	Record number	PEEP	Record number
0 cm H <sub>2</sub> O	49	0 cm H <sub>2</sub> O	53	0 cm H <sub>2</sub> O	57
5 cm H <sub>2</sub> O	50	5 cm H <sub>2</sub> O	54	5 cm H <sub>2</sub> O	58
10 cm H <sub>2</sub> O	51	10 cm H <sub>2</sub> O	55	10 cm H <sub>2</sub> O	59
15 cm H <sub>2</sub> O	52	15 cm H <sub>2</sub> O	56	15 cm H <sub>2</sub> O	60

<b>COPD model</b> $R_{rs} = 10 \text{ cm H}_2\text{O}\cdot\text{s/L}$ $C_{rs} = 80 \text{ mL/cm H}_2\text{O}$					
RR = 20 BPM					
P = 5 cm H <sub>2</sub> O		P = 10 cm H <sub>2</sub> O		P = 15 cm H <sub>2</sub> O	
PEEP	Record number	PEEP	Record number	PEEP	Record number
0 cm H <sub>2</sub> O	61	0 cm H <sub>2</sub> O	65	0 cm H <sub>2</sub> O	69
5 cm H <sub>2</sub> O	62	5 cm H <sub>2</sub> O	66	5 cm H <sub>2</sub> O	70
10 cm H <sub>2</sub> O	63	10 cm H <sub>2</sub> O	67	10 cm H <sub>2</sub> O	71
15 cm H <sub>2</sub> O	64	15 cm H <sub>2</sub> O	68	15 cm H <sub>2</sub> O	72

## Appendix B: The protocol of measurement for VCV mode

<b>Healthy model</b> $R_{rs} = 3 \text{ cm H}_2\text{O}\cdot\text{s/L}$ $C_{rs} = 60 \text{ mL/cm H}_2\text{O}$					
RR = 12 BPM					
V = 200 mL		V = 400 mL		V = 600 mL	
PEEP	Record number	PEEP	Record number	PEEP	Record number
0 cm H <sub>2</sub> O	1	0 cm H <sub>2</sub> O	5	0 cm H <sub>2</sub> O	9
5 cm H <sub>2</sub> O	2	5 cm H <sub>2</sub> O	6	5 cm H <sub>2</sub> O	10
10 cm H <sub>2</sub> O	3	10 cm H <sub>2</sub> O	7	10 cm H <sub>2</sub> O	11
15 cm H <sub>2</sub> O	4	15 cm H <sub>2</sub> O	8	15 cm H <sub>2</sub> O	12

<b>Healthy model</b> $R_{rs} = 3 \text{ cm H}_2\text{O}\cdot\text{s/L}$ $C_{rs} = 60 \text{ mL/cm H}_2\text{O}$					
RR = 20 BPM					
V = 200 mL		V = 400 mL		V = 600 mL	
PEEP	Record number	PEEP	Record number	PEEP	Record number
0 cm H <sub>2</sub> O	13	0 cm H <sub>2</sub> O	17	0 cm H <sub>2</sub> O	21
5 cm H <sub>2</sub> O	14	5 cm H <sub>2</sub> O	18	5 cm H <sub>2</sub> O	22
10 cm H <sub>2</sub> O	15	10 cm H <sub>2</sub> O	19	10 cm H <sub>2</sub> O	23
15 cm H <sub>2</sub> O	16	15 cm H <sub>2</sub> O	20	15 cm H <sub>2</sub> O	24

<b>ARDS model</b> $R_{rs} = 7.5 \text{ cm H}_2\text{O}\cdot\text{s/L}$ $C_{rs} = 30 \text{ mL/cm H}_2\text{O}$					
RR = 12 BPM					
V = 200 mL		V = 400 mL		V = 600 mL	
PEEP	Record number	PEEP	Record number	PEEP	Record number
0 cm H <sub>2</sub> O	25	0 cm H <sub>2</sub> O	29	0 cm H <sub>2</sub> O	33
5 cm H <sub>2</sub> O	26	5 cm H <sub>2</sub> O	30	5 cm H <sub>2</sub> O	34
10 cm H <sub>2</sub> O	27	10 cm H <sub>2</sub> O	31	10 cm H <sub>2</sub> O	35
15 cm H <sub>2</sub> O	28	15 cm H <sub>2</sub> O	32	15 cm H <sub>2</sub> O	36

<b>ARDS model</b> $R_{rs} = 7.5 \text{ cm H}_2\text{O}\cdot\text{s/L}$ $C_{rs} = 30 \text{ mL/cm H}_2\text{O}$					
RR = 20 BPM					
V = 200 mL		V = 400 mL		V = 600 mL	
PEEP	Record number	PEEP	Record number	PEEP	Record number
0 cm H <sub>2</sub> O	37	0 cm H <sub>2</sub> O	41	0 cm H <sub>2</sub> O	45
5 cm H <sub>2</sub> O	38	5 cm H <sub>2</sub> O	42	5 cm H <sub>2</sub> O	46
10 cm H <sub>2</sub> O	39	10 cm H <sub>2</sub> O	43	10 cm H <sub>2</sub> O	47
15 cm H <sub>2</sub> O	40	15 cm H <sub>2</sub> O	44	15 cm H <sub>2</sub> O	48

<b>COPD model</b> $R_{rs} = 10 \text{ cm H}_2\text{O}\cdot\text{s/L}$ $C_{rs} = 80 \text{ mL/cm H}_2\text{O}$					
RR = 12 BPM					
V = 200 mL		V = 400 mL		V = 600 mL	
PEEP	Record number	PEEP	Record number	PEEP	Record number
0 cm H <sub>2</sub> O	49	0 cm H <sub>2</sub> O	53	0 cm H <sub>2</sub> O	57
5 cm H <sub>2</sub> O	50	5 cm H <sub>2</sub> O	54	5 cm H <sub>2</sub> O	58
10 cm H <sub>2</sub> O	51	10 cm H <sub>2</sub> O	55	10 cm H <sub>2</sub> O	59
15 cm H <sub>2</sub> O	52	15 cm H <sub>2</sub> O	56	15 cm H <sub>2</sub> O	60

<b>COPD model</b> $R_{rs} = 10 \text{ cm H}_2\text{O}\cdot\text{s/L}$ $C_{rs} = 80 \text{ mL/cm H}_2\text{O}$					
RR = 20 BPM					
V = 200 mL		V = 400 mL		V = 600 mL	
PEEP	Record number	PEEP	Record number	PEEP	Record number
0 cm H <sub>2</sub> O	61	0 cm H <sub>2</sub> O	65	0 cm H <sub>2</sub> O	69
5 cm H <sub>2</sub> O	62	5 cm H <sub>2</sub> O	66	5 cm H <sub>2</sub> O	70
10 cm H <sub>2</sub> O	63	10 cm H <sub>2</sub> O	67	10 cm H <sub>2</sub> O	71
15 cm H <sub>2</sub> O	64	15 cm H <sub>2</sub> O	68	15 cm H <sub>2</sub> O	72

## **Appendix C: CD**

Attached CD contains following data:

- Key words in Czech and English language
- Abstract in Czech language
- Abstract in English language
- Scan of the assignment of the thesis
- Complete Bachelor's thesis
- Excel files with the data included in the thesis