

X-X (1:1)

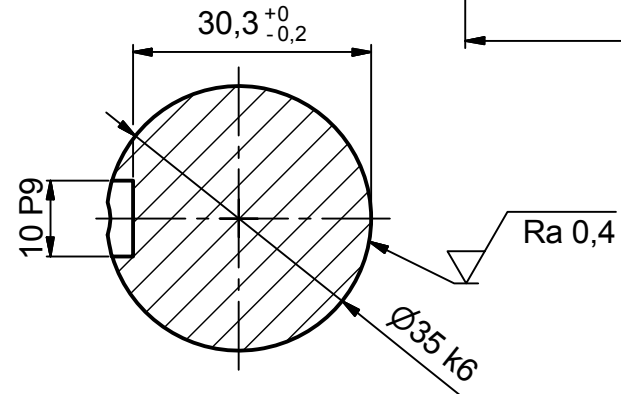

Y-Y (1:1)

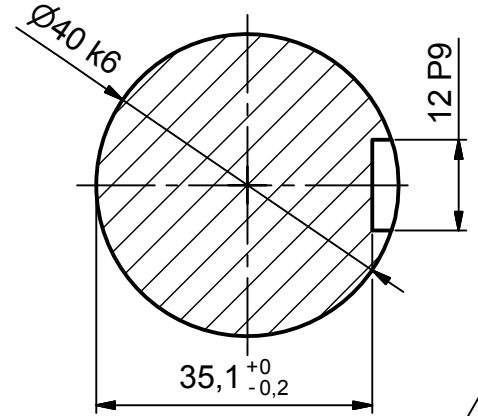

Z-Z (1:1)

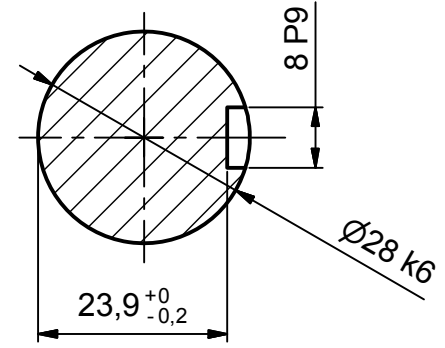

W (1:1)

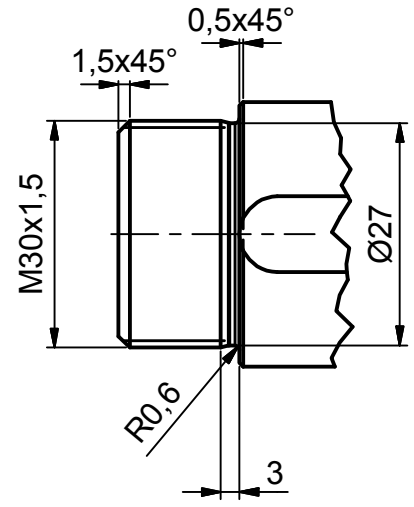

V (1:1)

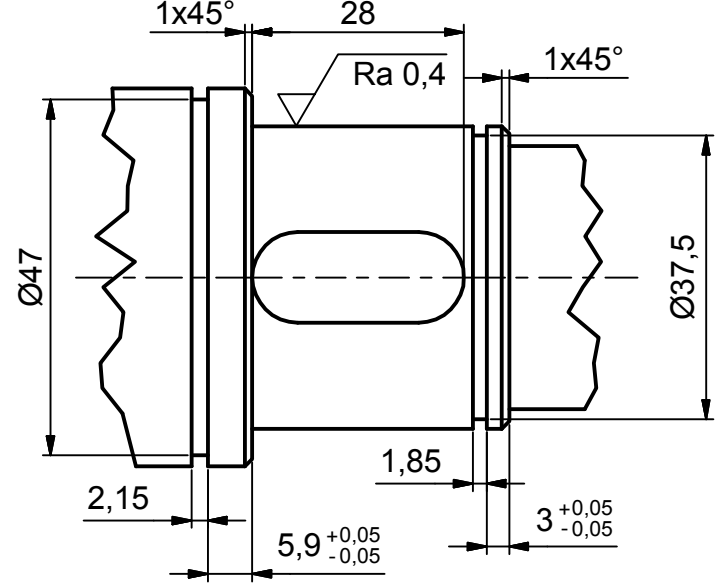

MATERIÁL: 12 050									
POLOTOVAR: KR55-529 ČSN 42 5510.12									
PROMĚTÁNÍ: (ISO E)		TOL. DLE ISO 8015:							
PŘESNOST ISO 2768 - mK									
VŠEOB. TOL. ISO 8062-									
Autor		Datum		Podpis		Datum		INDEX	
NAVRHL		PŘEZK.		HMOTNOST 5,896 kg		MĚŘITKO 1:2 (1:1)			
KRESLIL Kuchař Otakar		18.4.2017		SCHVÁLIL		SESTAVA		KUSOVNIK	
TECHNOL.				STARÝ V.					

ČESKÉ VYSOKÉ UČENÍ TECHNICKÉ V PRAZE
FAKULTA STROJNÍ
 NAZEV: **SIGNOVAČKA - HŘÍDEL 1**
 ČÍSLO VÝKRESU: **122802**
 LIST: _____