

# Vývojový diagram experimentu

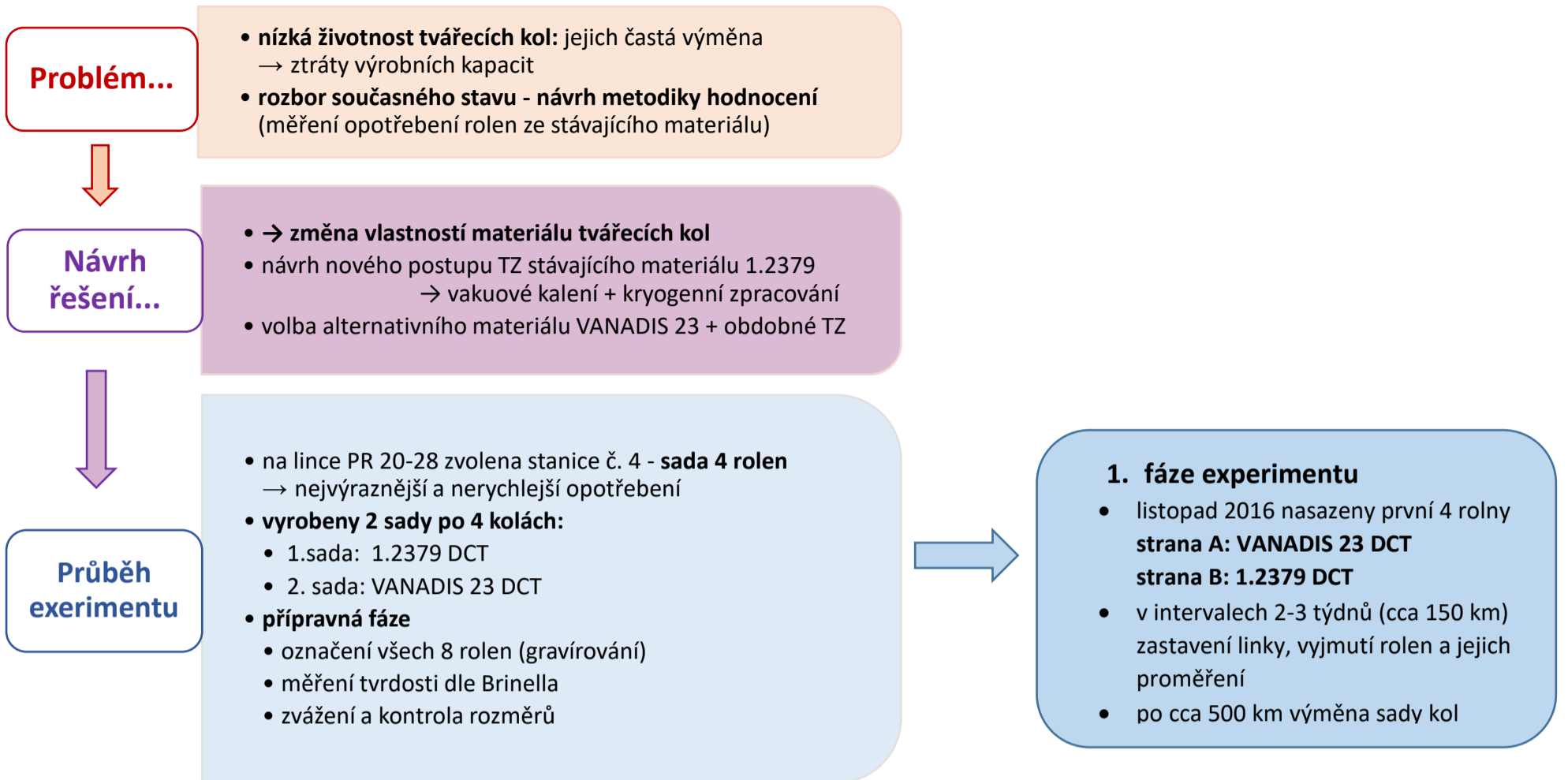

Strana A: 183722\_VCA, 183715\_VCA

Strana B: 183715\_NCB, 183725\_NCB



Schéma linky PR 20-28 a detail stanice č. 4 [48]

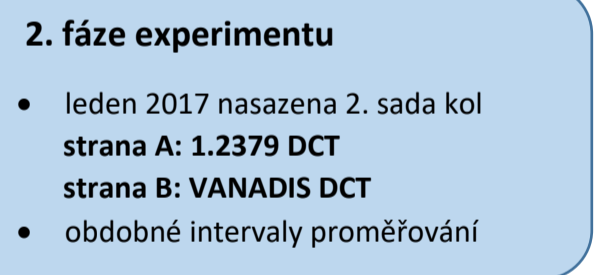
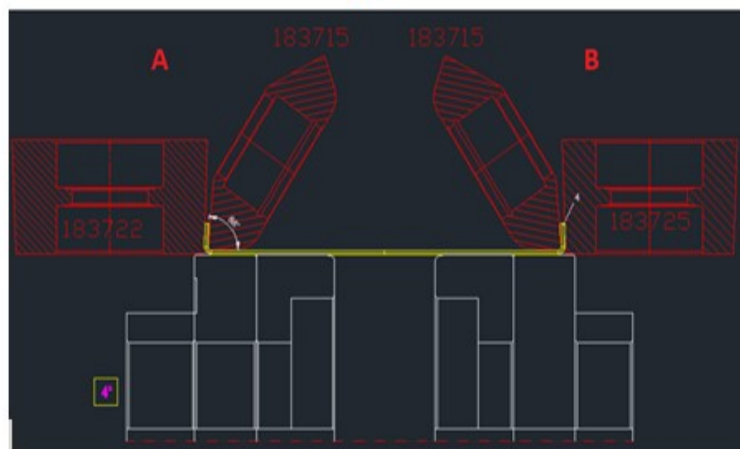
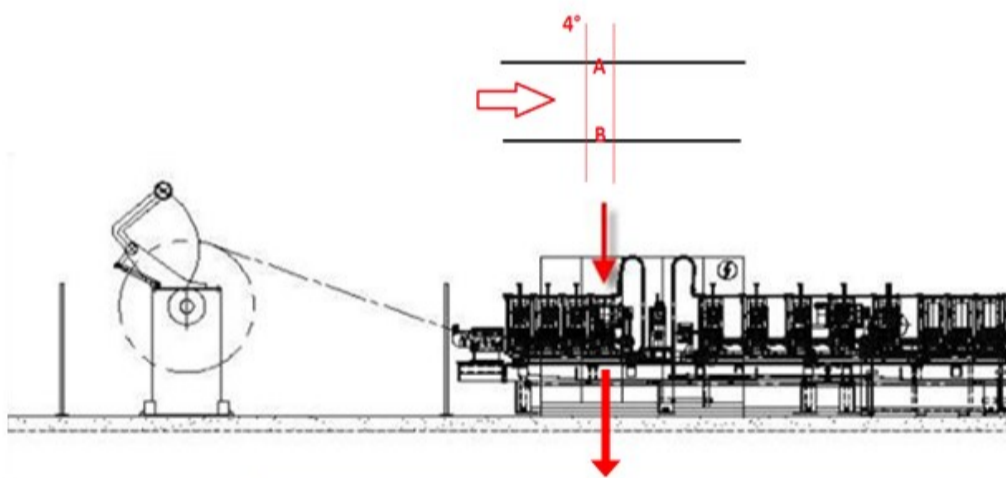

Strana A: 183722\_NCA, 183715\_NCA

Strana B: 183715\_VCB, 183725\_VCB

