

# **Czech Technical University in Prague**

Faculty of Electrical Engineering

Department of Economics, Management and Humanities

## **Process oriented organization**



Laura Hallérová

Study program: Software technologies and management

Study subject: Business informatic

Supervisor of the thesis: Ing. Pavel Náplava

Prague 2017

## I. OSOBNÍ A STUDIJNÍ ÚDAJE

Příjmení: **Hallérová** Jméno: **Laura** Osobní číslo: **437368**  
Fakulta/ústav: **Fakulta elektrotechnická**  
Zadávající katedra/ústav: **Katedra ekonomiky, manažerství a humanitních věd**  
Studijní program: **Softwarové technologie a management**  
Studijní obor: **Manažerská informatika**

## II. ÚDAJE K BAKALÁŘSKÉ PRÁCI

Název bakalářské práce:

**Process Oriented Organization**

Název bakalářské práce anglicky:

**Process Oriented Organization**

Pokyny pro vypracování:

- 1) Define terms process, business process management and Process Oriented Organization.
- 2) Analyze the present state of business process management and identify existing supporting software tools.
- 3) In agreement with the supervisor, perform process analysis of the selected organization and identify processes suitable for automatization.
- 4) Suggest an optimization of selected processes by using selected software tool.
- 5) Propose and apply performance indicators for evaluation of automatization benefits.

Seznam doporučené literatury:

1. Řepa V., Procesně řízená organizace, Grada, 2012, ISBN: 978-80-247-4128-4
2. Grasseová M. a kolektiv, Procesní řízení ve veřejném i soukromém sektoru, BIZBOOKS, Computer Press, 2008, EAN: 9788025119877

Jméno a pracoviště vedoucí(ho) bakalářské práce:

**Ing. Pavel Náplava, katedra ekonomiky, manažerství a humanitních věd FEL**

Jméno a pracoviště druhé(ho) vedoucí(ho) nebo konzultanta(ky) bakalářské práce:

Datum zadání bakalářské práce: **16.02.2017** Termín odevzdání bakalářské práce: **15.08.2017**

Platnost zadání bakalářské práce: \_\_\_\_\_

\_\_\_\_\_  
Podpis vedoucí(ho) práce

\_\_\_\_\_  
Podpis vedoucí(ho) ústavu/katedry

\_\_\_\_\_  
Podpis děkana(ky)

## III. PŘEVZETÍ ZADÁNÍ

Studentka bere na vědomí, že je povinna vypracovat bakalářskou práci samostatně, bez cizí pomoci, s výjimkou poskytnutých konzultací. Seznam použité literatury, jiných pramenů a jmen konzultantů je třeba uvést v bakalářské práci.

\_\_\_\_\_  
Datum převzetí zadání

\_\_\_\_\_  
Podpis studentky

## **Declaration**

I hereby declare that the presented thesis is my own work and that I have cited all sources of information in accordance with the Guideline for adhering to ethical principles when elaborating an academic final thesis.

I acknowledge that my thesis is subject to the rights and obligations stipulated by the Act No. 121/2000 Coll., the Copyright Act, as amended, in particular that the Czech Technical University in Prague has the right to conclude a license agreement on the utilization of this thesis as school work under the provisions of Article 60(1) of the Act.

In Prague on 11th August 2017

Laura Hallérová

## **Acknowledgements**

I would like to thank my supervisor Ing. Pavel Náplava from my home university, and Prof. Dr. Jörg P. Müller, who took role of my supervisor during my Erasmus studies, for their time, advices and support. I would like to also thank to my family and friends for their support.

## **Abstrakt**

Cieľom tejto bakalárske práce je popísať význam výrazu podnikový proces, procesne riadené organizácie, procesné riadenie a pojmy s tým spojené . Taktiež zhodnotiť súčasný stav procesného riadenia a popísať nástroje na podporu procesného riadenia.

Praktická časť práce obsahuje popis výberu organizácie pre procesnú analýzu. Organizáciou je Fakulta Elektrotechnická na ČVUT, na ktorej som previedla procesnú analýzu vybraných procesov vhodných pre automatizáciu. Pre vybrané procesy bola navrhnutá automatizácia, ktorá je zhodnotená pomocou metrík na meranie výkonnosti procesov.

## **Kľúčové slová**

podnikový proces, procesný manažment, procesne riadená organizácie, automatizácia procesov

## **Abstract**

The main goal of the bachelor thesis is to describe meaning of the term business process, process oriented organization, process management and other related terms. Next objective is to evaluate present state of business process management and define supporting tools.

Practical part of the thesis contains description of the choosing organization for performing process analysis. Chosen organization is Faculty of Electrical Engineering at CTU, where I performed analysis of the processes, which are suitable for automatization. For selected processes was proposed automatization, which is evaluated with metrics for measuring process performance.

## **Key words**

business process, process management, process oriented organization, automatization

# Content

List of tables.....	7
List of pictures.....	8
Introduction.....	9
Theoretical part .....	10
1. Business process .....	10
1.1. Definition of the business process .....	10
1.2. Groups of processes.....	10
1.3. Characteristic of processes.....	11
1.4. Goals of processes.....	11
1.5. Conclusion.....	12
2. Organization management.....	13
2.1. Types of organization management.....	13
2.2. Comparison of management types .....	14
2.3. Process oriented organizations.....	14
2.4. Conclusion.....	16
3. Preparation of organization for implementing business process management.....	17
3.1. Preparation for implementing business process management.....	17
3.2. Process analysis .....	18
3.3. Process performance.....	20
3.4. Process optimization .....	22
3.5. Conclusion.....	23
4. Process mapping .....	24
4.1. Notation for process mapping.....	24
4.2. Methods of process mapping .....	27
4.3. Tools for process mapping.....	28
4.4. Conclusion.....	29
5. Automatization of business processes.....	30
5.1. Camunda BPM .....	30
5.2. Conclusion.....	31
6. Present state of business process management.....	33
6.1. Private sector .....	33

6.2. Public sector .....	34
Conclusion of theoretical part.....	35
Practical part.....	37
7. Business process management at FEE CTU .....	37
7.1. Business process management at FEE CTU.....	37
7.2. Choosing of processes for process analysis and optimization .....	39
7.3. Selection of software tool.....	41
7.4. Request For Interrupting Studies .....	41
7.4.1 Process analysis.....	42
7.4.2 Suggesting the performance indicators.....	43
7.4.3 Optimization .....	45
7.4.4 Automatization of the process .....	45
7.4.5 Application of key performance indicators .....	51
7.5. Request For Later Submitting Of Final Thesis .....	55
7.5.1 Process analysis.....	56
7.5.2 Automatization of process.....	56
7.5.3 Application of key performance indicators .....	64
7.6. Conclusion of the practical part.....	67
7.6.1 Assets and dangers of the provided automatization.....	68
7.7. Next steps after project .....	69
Conclusion.....	70
Acronyms .....	72
Bibliography .....	73
Appendix.....	76



## List of tables

Table 1 - Process management in the private sector, [20].....	33
Table 2 - User form, Request For Interrupting Studies .....	48
Table 3 - Parameters of the subdean form, Request For Interrupting Studies ..	50
Table 4 - Subdean decision, request For Interrupting studies .....	50
Table 5 - KPI Interrupting of the studies .....	54
Table 6 - Description Request For Later Submitting Of Final Thesis, [23].....	55
Table 7 - Customer form, Request For Later Submitting Of Final Thesis .....	58
Table 8 - Parameters of the form, head of department .....	59
Table 9 - Decision, head of the department .....	60
Table 10 - Parameters of the form, supervisor .....	61
Table 11 - Decisions of the form, supervisor .....	61
Table 12 - Parameters of the form, officer.....	61
Table 13 - Parameters of the form, subdean .....	62
Table 14 - Desisions of the form, subdean.....	63
Table 15 - KPI Later submitting of the thesis.....	67

## List of pictures

Picture 1 - Example of the process.....	10
Picture 2 - Structure of the organization .....	14
Picture 3 - Activities.....	25
Picture 4 - Events .....	25
Picture 5 - Gateways .....	26
Picture 6 - Swimming pools.....	27
Picture 7 - Artefacts .....	27
Picture 8 - Camunda components .....	31
Picture 9 - CTU Process Portal .....	38
Picture 10 - CTU Process Portal service .....	39
Picture 11- Student's form, Request For Interrupting studies .....	47
Picture 12 - Officer, Request For Interrupting Studies .....	49
Picture 13 - Subdean, Request For Interrupting Studies .....	50
Picture 14 - Student form, Request For Later Submitting Of Final Thesis .....	59
Picture 15 - Head of department, Request For Later Submitting Of Final Thesis .....	60
Picture 16 - Officer, Request For Later Submitting Of Final Thesis .....	62
Picture 17 - Subdean, Request For Later Submitting Of Final Thesis .....	63

## Introduction

Topic of the bachelor thesis are process oriented organizations. Business process management is the philosophy of managing, which represents integrated concept of business process management from the start till the end, including elementary activities, that help create the product or services for the customer.

Firstly, I will try to set main goal of the thesis, which I will try to fulfil.

1. Explain term of business process, business process management and process oriented organization.
2. Evaluate present state of the business process management and name supporting software tools.
3. In the chosen organization select process suitable for automatization and perform process analysis of these processes.
4. Propose automatization of the processes using selected software tool, and evaluate automatization using performance indicators.

## Theoretical part

### 1. Business process

This section defines term business process, where is possible to find business processes and characteristics related to this term.

#### 1.1. Definition of the business process

In a daily life people often meet term process, the most frequently people meet this term in a world of the business and information systems. We can use word process almost in every situation. In the case, that we are talking about the process in a world of the business, we also have to define term business process.

Business process can be defined as a summary of the activities, which require one or more different kinds of the inputs and creates outputs, which have value for the customer. Every organization has a lots of business processes, which determine how to proceed during exact activities in organization. For example, in every organization, we can define set of the processes. Important aspect about processes is time. Each process, or we can say activity is executed in the time sequence. Thanks to time sequence, we can give order to activities. [5]

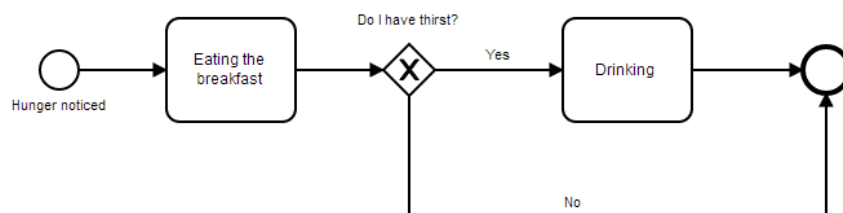

Picture 1 - Example of the process (source:author)

#### 1.2. Groups of processes

Processes we can divide to groups according to few criteria. General dividing of the processes contains 3 main groups of the processes, which are needs to define in the organization.

General dividing of the processes:

- Main processes
  - They have influence on product of the organization.
  - They related to the customer.
  - They make income.
- Management processes
  - They are important for supporting the main processes.
  - They are not customer related.
  - They are not making income.
- Support processes
  - They define elements of leading and administration of the organization.
  - They are helping coordinate and organize the main processes.

These 3 groups of processes can be divided to other subgroups, it is based on goals of an organization. [5] [3]

### **1.3. Characteristic of processes**

Business process is characterized by followed signs:

- Has an owner.
- Has a customer.
- Need an input.
- Has an output.
- Has clear defined start and end point.
- Has time parameters.
- Has its own parameters.
- Parameters of the process can be measured.
- Is repeatable. [1][16]

### **1.4. Goals of processes**

Goals of the process help to show, why we use processes and what is the main purpose of using them. For specification of process's goals we can use principals SMART.

- Specific

- Measurable
- Attainable
- Realistic
- Timely

These 5 principals are base, which should be use in every business process defined in organization. Any of these principals has higher priority than other, this is reason why is important to follow all the named principals. After applying these principals, created process has assets for organization. [5][15][16]

### **1.5. Conclusion**

Section 1, Business process, defined business process, explains where is possible to meet this term. Next is division of the processes, their characteristics and objectives of the processes. This section should help to understand what is the process in general and what is business process.

## **2. Organization management**

Objective of this section is to describe the types of the management, with the focus on the business process management. Next step is to compare types of the management, and specify advantages and disadvantages of each type.

### **2.1. Types of organization management**

Company is organizing company structure through its departments, coordination of the employees, and it all depends on type of organization management.

There are more types of the organization management. Type of the management chosen by company depends on the company's philosophy. Management is way of working with sources and company's structure. Basic types are functional and business process management.

Author of the functional organization management is Adam Smith. In the past, before organization started to use business process management, functional management was the most popular.

Basic of the functional management is to divide manufacturing process to smaller simple tasks. Purpose of spreading tasks to smaller tasks is to make easier complex procedure. Then easier procedures can be done by less qualified workers.

In 80s years of the last century companies started to use new type of management, business process management. The business process management was created, because companies were not able to increase their performance and make their customers satisfied, because offer was higher, than demand.

Creator of the business process management is Michael Hammer and James Champy. The main goal was to give importance to activity like to one unit, which is going through whole organization. It is not anymore important to focus just on the small functional units like in functional management. Also very important in business process management are informational technologies. [5][11]

## 2.2. Comparison of management types

Already mentioned functional and business process management, are based on the different philosophies. And both are different in the main aspects, beginning with company structure to the rewarding employees.

Functional management in organization has these main characteristic:

- On the first place is satisfaction of the company leaders.
- Adaption to needs of individuals.
- Rules are clearly given, they cannot be changed.
- Has boreoarctic / tall organizational structure.

Business process management in organization has these main characteristic:

- Customer is on the first place.
- Base is the team work.
- Is adaptive to the changes.
- Has flat organizational structure. [5][11]

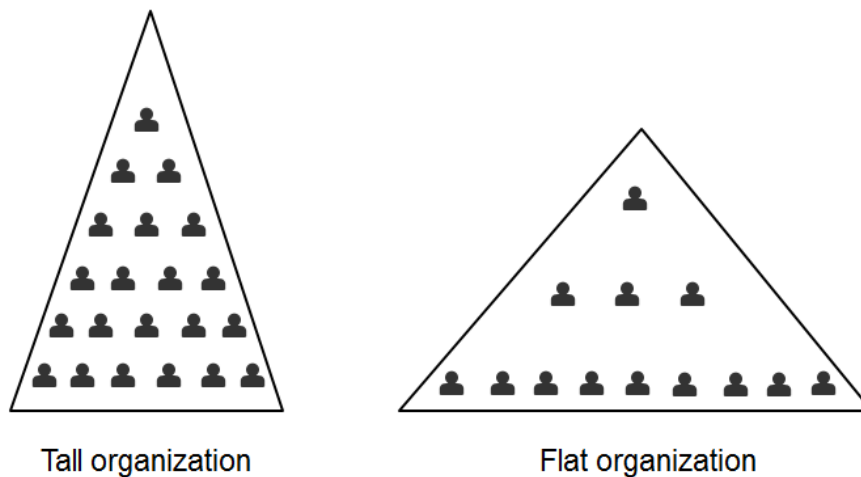

Picture 2 – Structure of the organization (source:author)

## 2.3. Process oriented organizations

### 2.3.1. Business process management in organization

Business process management is the leading of a company in the way, where business processes have important role. Base of the business process



management is to understand business logic and relation between activities performed in organization.

In the business process management business processes have the main role. The base is to understand the basic logic of the business and the connection between activities in organization. Everything mentioned is important to understand in a view of organization's strategy, considering not just organization's interests, but also customer's interests.

Business processes completely changed concept of way how employees organize they work and how they work in organization. Process includes every aspect of organization, for example technologies, leaders of the organization, method of performing employee's job, people's motivation and their rewarding. From processes, that represents single activities executed in organization, is necessary create continual activity. [6][11]

### **2.3.2. Motivation for applying business process management**

Motivation for applying business process management in organization it to reach few goals. Market is full and there is not enough customers. In the present, customer is not so fast replaceable, so amount of non-production positions in organization is growing, and is no more possible to divide work in small functional units. Organization must react quickly to requirements of the customer. In the past, it was sufficient to compete with price, but today is important to get advance also in other fields. Nowadays is relevant to make changes, due to continual innovation and organization cannot rely on old good practices.

In the conclusion, organization wants to reach the effective functioning with regard to current markets and competitors. Organization should be able to adapt to the market, changes of the market, and organization should work dynamically depending on the customer's requirements. [6]

### **2.3.3. Key benefits of business process management in the organization**

Implementing business process management in the organization brings many advantages and benefits.

- **Standardized working procedures**  
Thanks to implementing of the business process management, organization has to define procedures executed by employees. This is reason why we have process models, they are like whole map of the processes executed in the organization. Employees can be controlled by these process maps.
- **Easier optimization of processes**  
After processes are mapped, organization can easier optimize processes.
- **Defining of responsibilities**  
With defining processes is usually also defined owner of process. So, organization can create model of competence, which contain responsible person for each process.
- **Support of informational technologies**  
After optimizing of processes in organization, processes can be supported by information systems. [6]

### **2.4. Conclusion**

This section described types of the management are used and compared them. From the comparison was obvious that business process management has more advantages and is preferred nowadays. So, rest of the section contains more information business process management and process oriented organizations.

### **3. Preparation of organization for implementing business process management**

The main goal of this section is to describe steps how to implement business process management in the organization. Also, what are related activities with implementing business process management.

#### **3.1. Preparation for implementing business process management**

Implementing of business process management in organization always require preparation, which contains few steps. Before organization make final decision and start with business process management, organization should follow few basic steps:

- Determining the vision.
- Determining goals.
- Preparation of employees.
- Processing of project plan and choosing team for implementing the business process management.

Before organization starts with the business process management, management of the organization must have vision where and how wants organization work. Management has to determine vision, which tell what is expected from the changes.

Organization must have exact goals, which will reach. Path leading to changes of organization's working can be very difficult, but it important not to prioritize partial results instead of global results.

Important step is preparation of employees, which are used to do their job in some way and they don't care about other employees. Employees don't have overview, how their job fits to one unit with job of the other employees. It is important, that employee is not concentrated just on his own job, but also think about job of the other employees around.

Project of implementing business process management must contain exact plan, how will look steps of reorganization. Important is not to change leading employees, but to change organization and way of doing activities. Responsible for this project should be team of people, who will coordinate whole project from beginning till the end. [1][6][11][12]

### **3.2. Process analysis**

Process analysis help us to figure out, which processes should stay in same state and which processes are necessary to optimize or cancel at all.

Business process analysis is complex method, which helps to understand context of the business problem. Goal of business process analysis is to discover in logical or content context, why is process executed incorrectly.

Business process analysis can analyse following:

- Analysis of the process correctness

Organization should go through documentation of the process and check if can identify:

- Each activity, their requirements and dependencies of the activities
- Cooperating functional parts, roles and organizational structure
- Parts, where is required to approve something
- Structure and content of input places
- Used software tools and it's dependencies to related information
- Time requirement and terms of executing activities

- Analysis of the logical and context correctness

Organization should look for:

- Activities, that are not necessary for making final product
- Sequence activities, which can be executed parallel
- Multiplicity activities
- Relations between activities, which causes violating of time sequence
- Problems with competence of employees
- Useless time slots

- Loops causing repeating of sequence activities
- Analysis of process variants

The purpose is to find every possible variant of process. Also, to figure out if the process centralized or decentralized.

- Analysis of operating

We have to look at roles of employees and their relations to executed activities. The goal is to decrease costs related to consumption of human resources. In this case is important to define competence profile for every role.

- Analysis of informational systems and technologies

It is searched if process uses informational systems. If the process is not supported by informational system, we try to find the place where process should be supported by informational system and technologies. The goal is to increase supporting processes by informational technologies.

- Cost-benefit analysis

The idea is to determine ratio between costs and benefits. It is possible to use one of few methods. Choosing of method depends, if we are comparing costs and benefits using like metric money. Methods are following:

- CMA – Cost-Minimalization Analysis
- CBA – Cost-Benefit Analysis
- CEA – Cost-Effectiveness Analysis
- CUA – Cost-Utility Analysis
- ABC – Activity Based Costing
- Make or Buy

- Organizational analysis

Purpose of organizational analysis is to consider if the processes have optimal organizational structure.

There are also other methods of process analysis. It always depends on the subject, which organization want to improve and focus on. Every one of mentioned methods is focusing on the process from different view, so it organization can also use more methods in one time. [1][6][11][12]

### **3.3. Process performance**

After implementing business process management, it is necessary also measure performance of the processes and feedback from customer. Indicator of the performance helps to objective measure and evaluate process performance.

#### **3.3.1 Monitoring and measuring of the process performance**

Monitoring is usually related to qualitative properties like motivation, creativity, cooperation and others. Measuring is applicated to relation of elements and their influence to some quantity.

Relevance of measuring process performance is to evaluate process, find problems while considering whole process workflow. Performance measuring helps to reach strategic goals, evaluate the goals, what won't be able without measuring of performance, because we can't manage something, what we can't measure. It is also important to discover if some activities are not efficient and find out options for improvement. [3][5][20]

#### **3.3.2 Preparing for measuring process performance**

Before measuring or monitoring the process performance, is necessary to perform following steps:

- Update of process description
- Selecting of the process metrics
- Determining of the input values of the metrics
- Determining of the goal values of the metrics
- Analysis of the current methods for measuring process performance
- Integration of the metrics with the process [20]

### **3.3.3 Choosing metrics for measuring process performance**

Before choosing the metrics for measuring process performance, it is important to gather all available information about the process. After gathering information, like cost for process, number of employees and time of duration of each step of the process, the next step is brainstorming of experienced employees. Employees should determine advantages and disadvantages of the researched process. The owner of the process chooses measured metrics, according to the determined characteristics.

Metrics can be divided into the following groups:

- Minimizing of the process costs
  - Examples are costs for executing the process, time consumption.
- Correctness of the process
  - Examples are number of mistakes while executing the process.
- Duration of the process
  - Examples are waiting time between two steps in the process and time required for executing the process.
- Performance of the process
  - Example is number of successful executions of the process.

Also, there are other metrics that can be used for measuring or monitoring of the process. [3][5][19]

### **3.3.4 Conclusion of section process performance**

Realization of the measuring and monitoring of the process performance consists of collection and storage of the data, data analysis, evaluation of the process performance and realization of the measure.

Measuring and monitoring of the process performance is a very important step after implementing business process management in the organization. When an organization just thinks about metrics and tries to formulate them, it is also an asset for the organization. One of the biggest weaknesses of nowadays management is not using these metrics and measuring of these metrics. So every company, which tries to optimize processes should also focus on the process performance.

### 3.4. Process optimization

Process optimization is way of changing processes by improving their performance. After realization of process analysis, and identification of problems in processes, organization should realize optimization and suggest final proposal of process.

We can mention two ways of optimizing processes:

- Continuous improvement of business processes

Process is improved by small steps. The basis of process is not changing. Continuous improvement also can include lean administration.

The main idea of continuous improvement is that it doesn't matter how good something is, it always can be improved. All changes while continuous improvement of the business processes, don't change core of the process. Usually changes are related to decreasing of costs, optimization of available sources or elimination of activities without value. Changes have to be provided systematically, without skipping of important steps.

- Creating of new processes and business reengineering

Reengineering is basis rethinking and radical redesign of business processes for achieve dramatic improvement of actual performance indicators like price, quality, service.

Principals of reengineering:

- Is focused on the output, not on the task.
- Combine informational and process activities to real activities, which produce information.
- Connects parallel activities instead of integrating their results.

Organization can identify processes, which require reengineering by asking following questions:

- Which processes are the most problematic?



- Which processes are critical for fulfilling strategy of company and which processes have the biggest impact for customers?
- Can improving continue after finishing of required actions?
- What are the duties of process owners? [5][7][15][18]

### **3.5. Conclusion**

This section described steps of the implementing business process management and then activities related with business process management. The objective was to explain process analysis, process performance and process performance. All these things are closely related and are base of the business process management.

## 4. Process mapping

4<sup>th</sup> section should explain to reader what does mean the term of process mapping, what kind of notations, methods and tool are used.

### 4.1. Notation for process mapping

Purpose of process mapping is visualization of business processes. Process contains each steps, activities, and conditions for executing activity or decision, which leads to executing activity. Process mapping keep current processes documented, so then organization can create future business processes.

Necessary is also define term of process modelling. Process modelling is structured description of the processes. Process modelling is usually used for describing AS-IS and TO-BE processes. But process mapping just in the case of the AS-IS processes. In the thesis I will consider term of process modelling and mapping as the same term. [5]

We model processes using notation. There are more different notations. Every notation has its own rules and syntax, syntax can be different in each notation. In single organization is the best use just one notation, so responsible persons know her well and can understand its rules and syntax.

Some of notations are for example BPMN, UML, IDEF, EPC, NPC, RAD.

I decide to describe just notation BPMN, which will be later used in practical part. [8][18][25]

#### **BPMN (Business Process Model and Notation)**

BPMN standard, which was developed by group OMG (Object Management Group). Following section I created by using specification, which provide OMG. Main purpose of BPMN is provide to its users easily understandable and user friendly standard to all users, which are in contact with processes in organization. BPMN also provide option to move suggested process models close to implementing. So BPMN is using also by developers while automatizing processes.

Business processes are in BPMN modelled using graphic elements. Elements are divided into groups, which represent units, thanks to which is notation user friendly.

**Flow objects:**

- Activities are actions inside of process. We know 2 types of activities, subprocess and task.
  - Subprocess is dividing big processes to smaller units. Smaller processes are showed in BPMN notation.
  - Task is kind of subprocess, all tasks must be executed to reach the end of the process.



*Picture 3 – Activities (source:author)*

- Events are visualized by circle. Events introduce action, which have influence on executing of a business process. Also, time required for start of some process can be included in the activity. We can call events like catching activity, what means that for example after receiving some message, this activity will start another continue of action. Or we know also throwing events, which ends activity after receiving message.

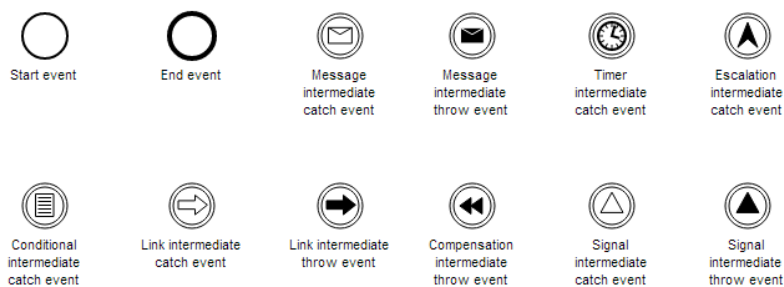

*Picture 4 – Events (source:author)*

- Gateways allow to merge and branch flows and processes. There are 5 types of gateways:
  - Exclusive gateway creates few possible ways, but flow can go just through one of them.
  - Inclusive gateway creates few possible ways and flow can go through more than one way and then all ways come together.
  - Complex gateway is used in cases, when we cannot use mentioned gateways and where are ways dividing in a few gateways.
  - Parallel gateway, flow is going through few gateways in a one time.
  - Event based gateway, flow is executed when event occurs.



Picture 5 – Gateways (source:author)

### Connecting objects:

- Sequence flow, we can use it for representing process flow. Source and goal is always activity, event or gateway. It cannot cross borders of the pool or subprocess.
- Message flow shows us, which messages crossing borders of the pool.
- Association is used for connecting artifacts or texts to flow objects. If association has an arrow, the arrow leading to artefact represent result and he arrow leading from artefact represent input.

### Swimming pools:

Swimming pools are dividing activities in to categories. For example, when we don't want to mix together activities of different responsible persons in organization.

- Pool is main element of a process and pool separate different parts of an organization. Process can contain more pools.
- Lanes are used to categorize process inside of a process.



Picture 6 - Swimming pools (source:author)

**Artefacts:**

- Data objects represent data, which are required to execute process.
- Groups are aggregating activities, groups don't have influence process diagram and they can cross borders of the pool.
- Annotations help to clarify process diagram. We use annotations in cases, when process is not understandable. [2][4][25]

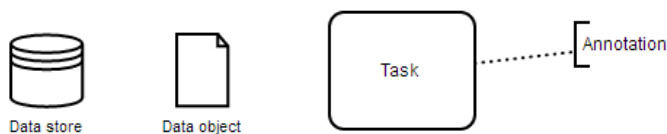

Picture 7 – Artefacts (source:author)

**4.2. Methods of process mapping**

Description of business processes can be done in different ways. We distinguish few methods of process mapping. All methods are usually related with tool, and they were also created for exact tool for process mapping. Method define how to

look at process and on what we should focus, while we are considering some process.

### **S-BPM**

Belongs to the group of subject oriented mapping. This method tries to show how persons execute each activity. Through process mapping, S-BPM helps to end user understand process. This method is supported by notation. The notation uses minimum of symbols, so the notation can be easily understandable for user.

### **ARIS (Architecture of Integrated Information System)**

ARIS is next method used for process mapping. ARIS use for modelling language EPC (Even-driven process chain). ARIS was designed for implementing business processes for informational systems.

ARIS distinguish 4 views:

- Organizational view
- Data view
- Control view
- Functional view

### **IDEF3**

IDEF3 is scenario managed method focused on capturing of the knowledge, how the systems work. It provides regime for:

- Process description of the capturing of the relations between activities in the exact activity
- Object transition state, which captures available states and requirements [8][18][22][25]

## **4.3. Tools for process mapping**

For process mapping, can be use more different tools, also called Business Process Modelling tools, some of the are:

- ARIS Business Architect
- Adonis
- Process Modeler
- QPR Process Guide
- IGrafX Business Process
- MS Visio
- Visual Paradigm
- IBM modeler
- Enterprise Architect

Every of these tools offer different scope of functionalities and different user comfort.

Every organization should choose tool, which fits all required criteria the most. We can use 4 groups of criteria, according to these groups we can rate and compare tools for process mapping. Groups of the criteria are:

- Applications
- Models
- Modelling of organization
- Processes

Every organization can use these criteria, choose the most important and then according to criteria choose tool, which is covering the biggest scope of required functionalities. [1][8][18][25]

#### **4.4. Conclusion**

This section explained term of process mapping, what is important for organization which is process oriented. Then were mentioned notations for process mapping, more detail was described BPMN notation, which will be important for practical part. As next are described methods and tool for process mapping.

## 5. Automatization of business processes

This section describes software tool, which can be used for automation of the processes. Idea of automate processes is based on the business strategy, which should integrate software applications through company and restructure work resources. For automatization, I chose software tool Camunda.

### 5.1. Camunda BPM

Camunda is company founded in 2008, and from beginning is focused on managing, effective proposing and realization of the business processes. Company Camunda took part in defining standard BPMN 2.0. Camunda is open-source platform based on Java, which enables process modelling and execute BPMN 2.0, also CMMN 1.1 and DMN 1.1.

#### Execute Models

The core is a model execution engine. It is used for executing BPMN, CMMN and DMN. It can run in any Java Virtual Machine. Engine can be accessed via the REST API. For access, can be also used the Java API and integration with Spring or Java EE.

#### Camunda Modeler

Camunda Modeler is free desktop modeler application. It is used for BPMN models, CMMN cases and DMN decisions. Camunda Modeler is user friendly, so it can be used by analytics and developers very easily. The modeler also allows to edit technical properties for technical executions. Thanks to fact that Camunda works on BPMN, CMMN and DMN XML files, it can be easily combined with preferred IDE, for example Netbeans, IntelliJ, Eclipse.

#### User environment Camunda BPM

After executing of process, all things related to the activities, setting the rights, user administration and others are managed in local web interface. This web interface has three main sections:

- Tasklist

During executing of the BPMN or CMMN model, Camunda will create task for end user. Tasks are assigned to end user according to the model. After



click on the task in Camunda, user will see the task form, which he should fill with required data. When user finish filling the form, he approves finishing by click on the button. Then Camunda Engine can continue with executing the model.

- Cockpit

This section use administrators, which inspect executed processes. Administrator doesn't have to be always just technical educated person, administrator can also be person from business department. Cockpit is high customizable, what enables to create various version of the Cockpit for specific use cases.

- Admin

This section use Administrators. Administrators can give to user's permissions, organize them in groups and manage them. [2][20][24]

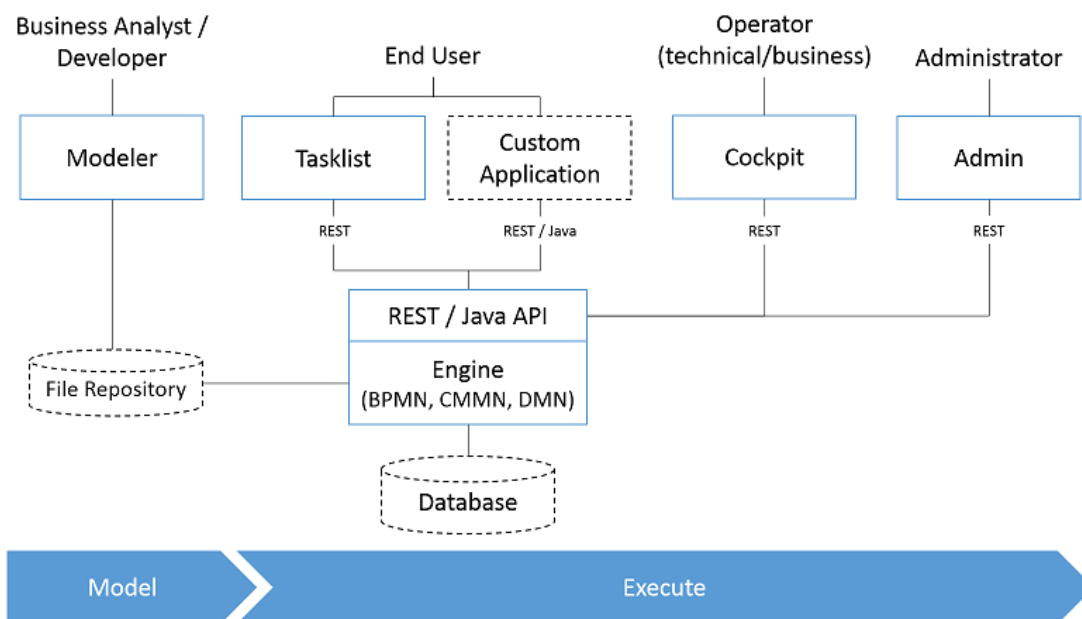

Picture 8 - Camunda components (source: [2])

## 5.2. Conclusion

In this section was described objective of the automatization of the business processes and software tool Camunda, which supports automatization. Camunda was also chosen for proposing the automatization in the practical part. Reasons for choosing this tool are:

- free software, at least in the first years is not necessary to invest to premium version
- supports BPMN, which is already used in CTU Process Portal and is well known at FEE [2]

## 6. Present state of business process management

In this section describes present state of the business process management according to the available information. Section contains 2 parts, the first part describing private sector and second part describing public sector.

### 6.1. Private sector

In private sector business process management started to grow around year 1990. From that time, almost every big, but also small company started to use ideology of the business process management. Business process management should bring higher quality to the companies, less waste and less effort. But not all companies are fully process oriented, or implement all ideas of the business process management.

In the book of David Tuček [19] is the comparison of the business process management in Czech private sector in years 2006 and 2013. Comparison is made from the view of management of the organizations. In the chosen organizations, they asked about using business process management according to the opinion of the managers. Followed table contain results from the survey from year 2013. [19][20]

Process management	Percentage
is unknown term	ca 26 %
is used partially	ca 42 %
is fully used	ca 29 %
specific usage	ca 0,5 %
can't tell	ca 0,5 %

*Table 1 - Process management in the private sector, [20]*

So, from the view of managers the most common is to use business process management in the companies just partially. In the 26 percent of the companies is business process management still unknown term and just 29 percent of the companies fully use process management. In the conclusion, business process management is still on its way to be fully used, because just one third of the companies completely took idea of the business process management.

Worldwide is also used quality management systems standard ISO 9000. This standard is based on the seven quality management principles:

- Customer focus
- Leadership
- Engagement of people
- Process approach
- Improvement
- Evidence-based decision making
- Relationship management

ISO Survey of Certification is made every year and it shows how many certificates are valid worldwide. In year 2014 there was totally 1 476 504, in the year 2015 it increased about 3% and final number of the certification was 1 519 952. [20]

## **6.2. Public sector**

Top universities around the world use principals of the business process management couple of the years. Typically used methods are Balanced Scorecards, Lean administration, also ISO standards are rarely used.

In the public sector in Czech Republic there was a few projects of Ministry of education, youth and physical education (IPN MŠMT), which were concerned about business process management in public sector.

### **IPN EFIN**

Main target of the project is support and improvement of effective management principals, focused on the economic and administrative process in the universities, institutions of tertiary education and other research institutions.

During the project, they focused on the principals and activities, which were successfully implemented in similar institutions in Czech Republic and abroad and in different sectors in Czech Republic. Project started with purpose implement effective management to reach increase of the usefulness of the provided activities and services of the institution. Other purpose is to increase

efficiency of spent resources. Realization of the IPN EFIN should support competitiveness of these institutions.

Process analysis during this project was performed with focusing on the metrics from private sector. Important was to focus on the project and business process management and using of the informational technologies for supporting management.

Project IPN EFIN is primary oriented on the administrative processes in the institutions of the tertiary education. These processes are considered as processes in the private sector. Focus of administrative processes can be constraining factor, because for optimizing of the processes in the organization is also important to know main processes and needs of the customer.

## **IPN KREDO**

Main goal of project IPN KREDO is defined like:

Project IPN KREDO follow the project IPN EFIN, which I mentioned before. At the universities are today some standardized methods for executing the processes, but also there are some differences between two executions of one process. Process management strategy at the universities will increase quality of the education at the expense of the quantitative parameters. This idea corresponds with the idea of the implementing business process management at the universities. [1][10][20][26]

## **Conclusion of theoretical part**

In the theoretical part was described term of the business process, business process management and business oriented organization. These terms will be used in the practical part to describe business process management at chosen organization. Next sections from theory were focused on the tool used for business process modelling and automatization of processes. Information about these tools are base for proposing automatization of the processes. Last section

about present state of the business process management helps to understand situation and consider selecting of the organization for the practical part.

## Practical part

### 7. Business process management at FEE CTU

After discussion with supervisor of my bachelor thesis, I decided to choose as an organization suitable for optimizing Faculty of electrical engineering at Czech Technical University (FEE CTU). Main reason for choosing FEE CTU is that I am student of the faculty, so I know some of the processes related to the students. Knowledge of the processes will be advantage while working on the process analysis and optimization

#### 7.1. Business process management at FEE CTU

Project of business process management at Faculty of Electrical Engineering started in year 2009. In the beginning were mapped current processes at the Administrative office. Goal of this project was to bring transparency of the performed activities and to specify activities belonged to this department.

For graphical representation of the processes was chosen standard BPMN, as one of the user-friendly standard, because this standard can be easy understood by analytics and also faculty officers. Software tools used for cooperating with BPMN notation where IBM Blueworks Live, QPR ProcessGuide Xpress and now tool, which was internally developed. Also, last year was released new version of Process portal for Czech Technical University.

For gathering all processes was created CTU Process Portal. CTU Process Portal is information system, which contains all processes and services, that were mapped at FEE CTU. The portal serves to students and employees of the university. The objective is to avoid mistakes while executing process, save time and increase satisfaction. This year was released new version of the Process Portal. In the followed picture is printscreen from new CTU Process Portal, where is marked section with processes and services. [27]

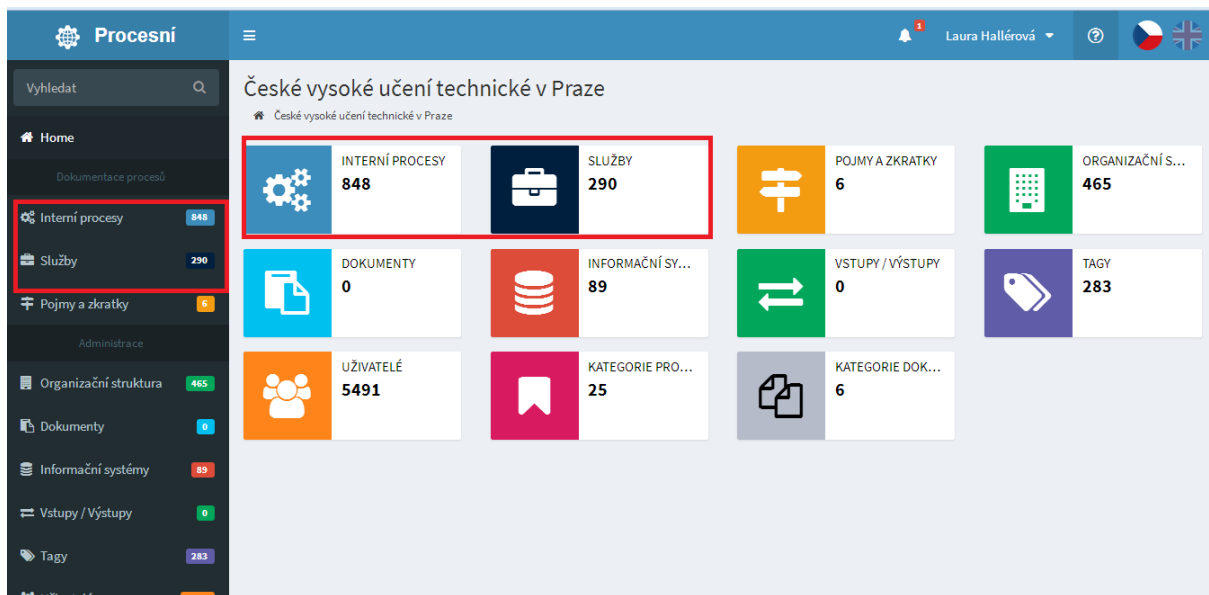

Picture 9 - CTU Process Portal (source: [23])

Project was the first attempt to implement business process management, so it also brought many doubts to employees and management of the faculty.

Services are primary aimed to customers of the university. Services show in the process just view of the customer, they show to customer how he should perform each step in the process. But in services customer cannot see, which steps are executed on the side of the organization. In the CTU process portal owners of the processes and also administrators can edit processes, when they are signed in the portal. For editing the process, user can use integrated software tool based on the BPMN notation. Also, all processes are available just after signed in to the portal. In the followed picture is example how is showed service to the student. [13] [14]



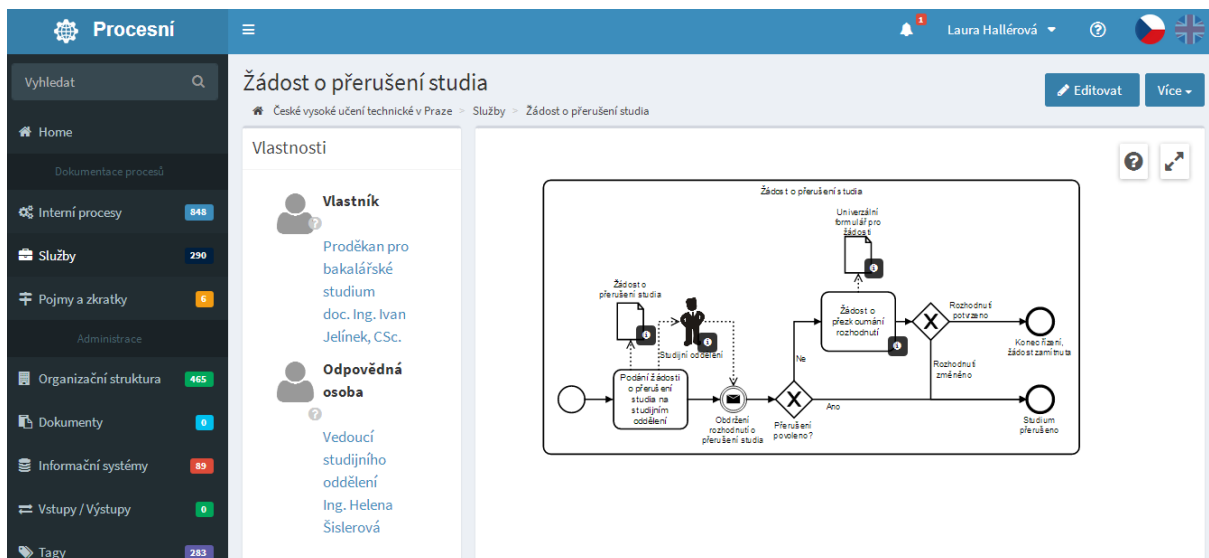

Picture 10 - CTU Process Portal service (source: [23])

## 7.2. Choosing of processes for process analysis and optimization

In this section I will describe steps, how I chose the processes for process analysis and later optimization using automation. Because CTU process portal contains many processes from the Faculty of Electrical Engineering, I set criteria, which will help to pick group of the suitable processes for the process analysis. Chosen criteria are:

- Repeatability – this criterion was chosen to select processes, that are executed with some considerable frequency. Some processes mapped at CTU process portal are executed just couple of time in an academic year, so thanks to this criterion I wanted to avoid this processes. A lot of processes, more than half of the all, were excluded after applying of this criterion.
- Time consuming – important criterion is that process is executed in the final time interval. It means that process should have certain start and end, so process will not stop in the loop. Also, the execution of the process doesn't take more than couple of days or few weeks.
- Processes related to students – relevant while doing analysis and followed optimization is to know remarks from the customer point of view. So as a student of the faculty, I can suggest optimization more easily when the

process is related to the students, because I know advantages and disadvantages of the processes.

- Potential for automatizing of the process – while choosing processes for later analysis and optimization, I considered also if the process has potential to be automatized.

Using these criteria for processes in CTU Process Portal, I selected group of processes, that fulfil conditions. Now I can consider these processes as good candidates for analysis and optimization.

Selection was made from even 500 processes and almost 300 services from FEE mapped at CTU Process Portal. First after implementing the chosen criteria, were selected around 10 processes. These processes seem to be suitable for next continuity in the work. But some in the case of some of the processes were information not described in the required detail, or they were described just as services. This require more contact with organization, what was not possible at the time of working on thesis, because I was at the university abroad.

Final selected processes are:

- Request for interrupting studies
  - Repeatability  
In the case of this process there are not statistic about number of sent requests, but the process has potential to be executed around tents times in the one academic year.
  - Time consuming  
Average time for process to perform from the beginning till the end is one or two days. Also, process doesn't contain any loops, which should cause violating of the process execution.
  - Process related to students  
Request For Interrupting Studies is request, which apply students, when they need to interrupt their studies for some specific reasons.
  - Potential for automatizing of the process

Process of sending the request is now not supported by any software tool. Students apply just in paper form, and also decision is sent just in paper form, what creates potential for automatization.

- Request for later submitting of final thesis
  - Repeatability
 

Every academic year hundreds of students works on the final thesis, and tents of them request for later submitting.
  - Time consuming
 

Process doesn't contain any loops or waiting time, which can cause average duration of process longer than week or which can cause not ending of the process.
  - Process related to students
 

This request applies students of the last bachelor and master studies, when they require more time for finishing their final thesis.
  - Potential for automatizing of the process
 

Today is process of requesting of later submitting of the final thesis performed in the paper form, and applying or sending the decision is not supported by any software tool. [1][23]

### 7.3. Selection of software tool

As a tool for implementing automatization of selected processes was chosen tool Camunda. This software was described in the section *Automatization of business processes*, where are also included reasons why was chosen this software tool. [2]

### 7.4. Request For Interrupting Studies

Process of Request For Interrupting Studies is one of the processes mapped at CTU process portal. The next step is to describe this process as AS-IS process. From this state, we can see how is process set in the present, also see the potential process's weakness and the problems, that can occur while executing the process. [23]

Attribute	Characteristic
-----------	----------------

Name of process	10 – Interrupting of studies
Owner	Subdean for student’s affairs
Responsible person	Head of student office
Specification of the process	Officer from student office receive request for interrupting studies. Officer processes request, gather information required about student, then deliver request to subdean. Subdean make final decision and can confirm or reject request.
Output of the process	Interruption of student studies or rejection of request for interrupting of studies.
Start events and conditions	Student sends request, student didn’t pay university payment or request is sent from dean’s initiative.
Documents	Form – Request For Interrupting Studies.
Information systems	KOS – university information system.

*Table 1 - Description table - Request For Interrupting Studies (source: author)*

### **7.4.1 Process analysis**

Process analysis was done according to the information from process diagram at CTU Process Portal, email consultation with subdean for student’s affairs and student’s officer.

#### **7.4.1.1 View of process correctness**

- In the process diagram is missing form, which student should fill for requesting interrupting of studies.
- In the process diagram is missing description of potential dean’s motion to request interrupting of studies of selected student.
- Process is available at the section Appendix, as Process 1.

### **7.4.1.2 View of logical and context correctness**

- Decision doesn't have to be send just by letter. According to new law, decision can be delivered to student by information system. Period for sending request of review of decision start at day of publishing decision in information system.
- There is no time limit for activities. Also, process does not include exact time limit for request of review of decision.

### **7.4.1.3 View of informational system/ technologies**

- Decision of request is saved in KOS, university informational system, where student office worker put information about request and result of request.
- Officer from student office must check in KOS student's semester, possibility of ending student's studies, and if it is needed check other information in KOS for making statement for subdean to help him make decision.
- This process is executing in paper form from beginning till the end. [23]

### **7.4.2 Suggesting the performance indicators**

For suggesting and evaluating key performance indicators (KPI) is required to collect information about processes. Also, discovering of the main problems results from the process description. According to the suggested performance indicators, I can focus optimization of processes on the exact process weaknesses. Chosen performance indicators consider characteristic of the process, in which process can be improve and that is reason to provide optimization according to these indicators. After realizing the optimization, we can evaluate process by measuring and monitoring chosen criteria. After that, we can decide if performing of the optimization reached settled goals.

- Average time for duration process

Average time for executing process is time from the start event till the end event of the process. This metric contains also waiting time between each step in the process. If some unexpectable waiting time occurs in the process, it will be counted to this time.

- Time cost

The time cost express time needed for executing a process. We calculate it like sum of time of executing each step in the process. In the sum, we don't add waiting time between two steps. We can refer time cost for every process attendant.

- Number of successful executions

Number of successful executions shows how many times was process executed from the start to the end event without any violation. Sometimes can occur unpredictable situation and process can't come to the end event. Also mistake can occur on the side of the customer, while filling the form or on the side of the organization, while making the statement or decision.

- Information security

It means damaging of documents, losing documents and losing or publishing the personal information about customer. According to these reasons, is way to increase information security minimize the number of documents saved in the paper form.

- Customer satisfaction

In the business process management is importance on the customer, what is reason for monitoring customer opinion and remarks, and keep customer satisfied. This indicator can be monitored in different way and results show to organization, if executing process should be improved from the view of customer.

According to these performance indicators I suggested analysis, optimization and followed automatization of the process. These indicators help to choose way how to look at the optimization of the processes, and what should be considered during optimization. These indicators can help to increase performance of the process, what can be shown by measuring them before and after performing the optimization.

I will use these performance indicators for both processes. Firstly, I will measure key performance indicators in each process before optimization, according to the information provided by subdean of the Faculty of Electrical Engineering and information resulted from the CTU Process Portal. And then I compare values of the key performance indicators after performing optimization. [1][21]

### **7.4.3 Optimization**

In this part I will describe steps of providing optimization. Optimization I will provide in case of these processes will be based on the continuous improving of the processes. The main purpose of optimization I provided is to automatize processes. Automatization should make execution of the process easier for customer and organization. This should result to the benefits and satisfaction of the both sides, what can be monitored by key performance indicators.

The goal of this thesis is to propose optimization of selected processes. Optimization will be provided by automatizing of the process using selected software tool.

### **7.4.4 Automatization of the process**

This section describes proposing of the automatization of the process Requesting For Interrupting Studies. I am suggesting automatization of the process, thesis contains basic ideas about automatization complemented by TO-BE process and main features of the future Camunda application.

#### **7.4.4.1 Workflow of TO- BE process**

This process can start every student, which already finished the first year of studies. In the process is involved student, worker of student's office and subdean for student's affairs.

Student has following options during executing of the process:

- Create request and fill required personal information.
- Attach required documents.
- Receive decision of request.

Worker of student's office has following options during executing of the process:

- Create request for interrupting studies of student, in special cases.
- Make statement for subdean, if request should be approved or rejected.
- Approve or reject student's request.
- Arrange sign of subdean and send answer of the request to student.

Subdean for student's affairs have following options during executing of the process:

- Make statement about student's request.
- Approve or reject student's request.

Proposal of workflow of TO-BE process is available at section Appendix, as *Process 5 - Interrupting Of Studies, Camunda workflow, (source: author)*.

#### **User Task – Filling the form**

Student starts the process Request for the interrupting studies, so at that time is created user task for the student. Student has to fill the form of request with required data. Required data are listed in following table. Some of the information are filled in advance, some of them student has to fill, or student has right to change them. Example of the student's form is in the Picture 11.





Name  Form of the studies

Surname  Address  

Date of the birth  Postal code  



Student's subject  Phone contact  

Student's program  Start date  

Year of the studies  End date  

Reason  

 Add attachment

 Cancel  Send

Picture 11- Student's form, Request For Interrupting studies (source:author)

ID	Type	Filled
lastName	string	Filled
firstName	string	filled
dateOfBirth	Date	Filled
studentSubject	enum	Filled
studentProgram	enum	Filled
yearOfStudies	enum	Filled
formOfStudies	enum	filled
Address	string	filled/ can be changed
postalCode	string	filled/ can be changed

phoneContact	string	filled/ can be changed
startDate	Date	Empty
endDate	Date	empty
Reason	string	empty

Table 2 - User form, Request For Interrupting Studies (source:author)

### **User task – Creating request**

If the request for the interrupting of the studies is not initiated by student, officer from student's office has to create request. Information, which are not filled in the advance are filled by the officer from student's folder.

### **User task – Making statement about the request**

This task is assigned to the officer from student's office. Officer is notified about this task by email. Officer see all attributes of the form filled by the student, but all attributes are in the form just for reading, they cannot be changed. Officer can add statement by using comment. The form, which is filled by officer can look like in Picture 12.

Name	<input type="text" value="Name"/>	Form of the studies	<input type="text" value="Form"/>
Surname	<input type="text" value="Surname"/>	Address	<input type="text" value="Address"/>
Date of the birth	<input type="text" value="Date"/>	Postal code	<input type="text" value="Postal code"/>
Student's subject	<input type="text" value="Subject"/>	Phone contact	<input type="text" value="Contact"/>
Student's program	<input type="text" value="Program"/>	Start date	<input type="text" value="Date"/>
Year of the studies	<input type="text" value="Year"/>	End date	<input type="text" value="Date"/>
Student's reason	<input type="text" value="Student's comment"/>		
Student's attachment	<input type="button" value="Download"/>	<input type="button" value="View"/>	
Officer's statement	<input type="text" value="Insert statement"/>		
	<input type="button" value="Cancel"/>		<input type="button" value="Send"/>

Picture 12 - Officer, Request For Interrupting Studies (source:author)

### User task – Making decision and statement about the request

This task is assigned to the subdean for student's affairs. Subdean is noticed about this task by email. Subdean can see all attributes of the form filled by the student and statement written by officer. Subdean doesn't have rights to change filled form, everything in read only form. Subdean can write statement about his decision in the form of comment and can make decision about the request.

ID	Type	Validation
SubdeanComment	string	Required
SubdeanDecision	enum	Required

Table 3 - Parameters of the subdean form, Request For Interrupting Studies (source:author)

Subdean has just two options, while making decision in the case of these request. Exemplar of the subdean's form is in the Picture 13.

ID	Name
Decision1	Approved
Decision2	Refused

Table 4 - Subdean decision, request For Interrupting studies (source:author)

The form contains the following fields and controls:

- Name:** Input field with placeholder 'Name'
- Surname:** Input field with placeholder 'Surname'
- Date of the birth:** Input field with placeholder 'Date'
- Student's subject:** Input field with placeholder 'Subject'
- Student's program:** Input field with placeholder 'Program'
- Year of the studies:** Input field with placeholder 'Year'
- Form of the studies:** Input field with placeholder 'Form'
- Address:** Input field with placeholder 'Address'
- Postal code:** Input field with placeholder 'Postal code'
- Phone contact:** Input field with placeholder 'Contact'
- Start date:** Input field with placeholder 'Date'
- End date:** Input field with placeholder 'Date'
- Student's reason:** Text area with placeholder 'Student's comment'
- Student's attachment:** Two buttons: 'Download' (with a download icon) and 'View' (with an eye icon)
- Officer's statement:** Text area with placeholder 'Officer's statement'
- Reason:** Text area with placeholder 'Insert reason' and a small pencil icon to its right.
- Bottom controls:** Two buttons: 'Cancel' (with a trash icon) and 'Send' (with a checkmark icon).

Picture 13 - Subdean, Request For Interrupting Studies (source:author)

### **Service task - Generating of document**

Document is generated according to the subdean's decision. Decision can be 2 types:

- Request is approved by the subdean for student's affairs.
- Request is refused by the subdean for student's affairs.

User task – Printing document and arranging the sign of subdean

Officer has to check generated document. Generated document is sent to officer's email. Then officer can check document and print it. Officer has to handle printed document to the subdean's to sign the document.

### **User task – Sending of the decision**

This task is assigned to the officer. Officer send decision of the request to the student by email and by the post. Sending letter by the post is described more in detail in other process.

### **7.4.4.2 Conclusion of the automatization**

In this section, will be concluded which problems automatization should be solved after performing automatization. In the first place this automatization will save the time of the customer and will make easier requesting interrupting of the studies. To this aspect is related KPI time consuming and average duration of the process. Automatizes process will also avoid potential problems with filling the form by student or organization, and decrease of the chance of damaging or losing student's request. To last two problems are relates KPI's number of successful executions and information security.

### **7.4.5 Application of key performance indicators**

In this section I will apply selected performance indicators on selected processes. Applying indicators helps to compare process before and after optimization and summarize if optimization and implementing automatization will bring advantages to customer and organization.

### **7.4.5.1 Average duration of the process**

#### **Before optimization**

In the present average time for executing the process of requesting interrupting of studies takes from one to two days, or more depending on the way how is request delivered to the office. From all activities performed in this process, the most time require student for filling and delivering the form. Other activities are not so time-consuming, the waiting time can occur when officer send request statement to subdean and wait for his answer.

#### **After optimization**

After optimization, employees and customers should not expect decreasing of the time. Just some steps in the process will decrease time, but there still will remain the waiting time. And after measuring whole time of the process from the start to the end, time will be with small changes or the same as before implementing automatization. Time can be saved, when student doesn't have to deliver personally and fill all information, because information will be filled automatically.

### **7.4.5.2 Time cost**

#### **Before automatization**

Before automatizing of this process the most critical activity is what student has to do. Student has to find online form and fill it and then send to the institution, or student has to go in person to the student's office to take the form. Also, student has to be careful while filling the form, to not make mistakes. Other critical part of this process from the view of the time cost of officer. Officer must check all filled information in the form and compared them with information in the KOS.

#### **After automatization**

After automatization of process, when we make sum of all activities will be lower. Time will be saved on the both sides, customer and organization side. Customer will save time by sending application after automatization of the request, student can use online form what is faster way than dealing with the paper form.

Some of the information will be filled automatically. Also, office worker doesn't have to control paper form, if all information about student studies are correct, because it all will be filled for student in online form.

### **7.4.5.3 Number of successful executions**

#### **Before automatization**

In case of Request For Interrupting Studies at Faculty of Electrical Engineering doesn't exist statistic monitoring number of sent requests, according to the information from subdean. In one academic year, there is just a few cases in which come to a mistake from side of customer of student's office.

#### **After automatization**

In this case, also before automatization rate of mistakes was very low. After automatization of process mistakes will occur with even lower probability, due to form will not be any more filled on the paper, but in online form. In online form, will be some information filled automatically, so it reduces probability of making mistakes.

### **7.4.5.4 Information security**

#### **Before automatization**

In case of working with paper form of requests exist some threats that can possibly happen, like losing documents. Other problems can also occur during period of mandatory archiving of documents. This scenario maybe doesn't occur so often, but while working with paper form, it can happen by accident at any time.

#### **After automatization**

While using online forms, safety of information will be significantly increased. Because of working with electronic documents, information cannot be physically damaged. Also in case of damaging of the electronic documents, with backup documents on the server, user won't lose all his information.

### 7.4.5.5 Customer satisfaction

#### Before automatization

At the present, student can download the form from web pages of the faculty, or can take form from student's office. Than after filling the form, student can send it by post or bring it directly to the student's office.

#### After automatization

Using online application for sending request will save student's time. Student doesn't need to search for the form on the faculty web pages, or to go to the student's office. Saving student's time is important factor, and will increase satisfaction of students. Also, things like increasing of informational security, decreasing of mistakes in filling the form will make students more satisfied.

### 7.4.5.6 Conclusion – application of the key performance indicators

Following table contains evaluation the key performance indicators. Table compares each key performance indicator after automatization with the indicator before automatization. Comparison is done by stating, if the key performance indicator is improved (☺) or the same (☹). It is not expected to get worse in the any case, because automatization was focused on these indicators.

Performance indicator	After automatization comparing to state before
Average duration of the process	☺
Time cost	☺
Number of successful executions	☹
Informational security	☺
Customer satisfaction	☺

Table 5 - KPI Interrupting of the studies (source:author)

After evaluating of the key performance indicators, it is obvious, that any of the indicators should have worse values after automatization. Automatization will guarantee improving in the case of time cost, informational security and



customer satisfaction. The other indicators will stay same, and automatization doesn't influence them in so big range. [1][3][23]

### 7.5. Request For Later Submitting Of Final Thesis

Request For Later Submitting Of Final Thesis is not in the form of process at CTU Process Portal. The information about process were taken from service and process, which describes handling general request.

Attribute	Characteristic
Name of process	Request for later submitting of final thesis
Owner	Subdean for student's affairs
Responsible person	Head of student office
Specification of process	Student fill the request, get agreement from head of department and supervisor. Then student deliver filled request to student's office. Officer makes statement, send statement to subdean. Subdean makes decision and then sign request. Officer send answer to student and add answer to KOS.
Output of process	Request was rejected, or request was approved and student will get new dead-line for submitting final thesis.
Start events and conditions	Student is assuming, that he will not submit thesis in the time.
Documents	Form for later submitting of final thesis.
Information systems	KOS – university information system.

Table 6 - Description Request For Later Submitting Of Final Thesis (source:author), (source:author)

## **7.5.1 Process analysis**

### **7.5.1.1 View of process correctness**

- In process diagram is stated that answer is requested from dean, but final decision is made by subdean. Request is delivered by officer to subdean who approves or refuses the request.
- Process is available at section Appendix, as the Process 2 and Process 3.

### **7.5.1.2 View of logical and context correctness**

- Decision doesn't have to be send by letter. According to new law, decision can be delivered to student by information system. And period for sending request of review of decision start at day of publishing decision in information system.
- It is not defined how long before final dead-line can student request for later submitting of the final thesis.

### **7.5.1.3 View of informational system/ technologies**

- Result of request is saved in KOS. Result is written to KOS by officer. Student can see new deadline in KOS in detail of section for final thesis.
- Student can find electronic version of form for request on faculty web pages.
- Officer must check in KOS, if student is working on the thesis first or second time. If it is second time, then officer has to check if before student also requested for later submitting of thesis and when will student cross normal study length. [23]

## **7.5.2 Automatization of process**

### **7.5.2.1 Workflow of process after automatization**

This process can start every student, who already finished first year of studies. In process is involved student, worker of student office and subdean for bachelor/ master studies.

Student has following options during executing of the process:

- Create request and fill required personal information.

- Attach required documents.
- Receive decision of request.

Worker of student's office has following options during executing of the process:

- Make statement, which will send to subdean.
- Approve or reject student's request.
- Arrange sign of subdean, student's supervisor, head of the department and send answer to student.

Subdean for student's affairs have following options during executing of the process:

- Make statement about student's request.
- Approve or reject student's request.

Supervisor of student's final thesis has following options during executing of the process:

- Make statement about student's request.
- Approve or reject student's request.

Head of department, where should be submitted student's final thesis, has following options during executing of the process:

- Make statement about student's request.
- Approve or reject student's request.

Proposal of workflow in Camunda is available in the section Appendix, as Process 4.

### User task – Filling the form





Initial task after starting of process execution is assigned to the student. Student has to fill the form of the request. Some of the information will be filled automatically, the rest has to fill student. Student approve and send filled form.

ID	Type	Filled
lastName	String	Filled



firstName	String	Filled
dateOfBirth	Date	Filled
studentSubject	Enum	Filled
studentProgram	Enum	Filled
yearOfStudies	Enum	Filled
formOfStudies	Enum	Filled
Address	String	filled/ can be changed
postalCode	String	filled/ can be changed
phoneContact	String	filled/ can be changed
Reason	String	Empty
Supervisor	String	Filled
nameOfThesis	String	Filled

Table 7 - Customer form, Request For Later Submitting Of Final Thesis (source:author)

Exemplar of the student's form is in the Picture 14.

Name	<input type="text" value="Name"/>	Form of the studies	<input type="text" value="Form"/>
Surname	<input type="text" value="Surname"/>	Address	<input type="text" value="Address"/> 
Date of the birth	<input type="text" value="Date"/>	Postal code	<input type="text" value="Postal code"/> 
Student's subject	<input type="text" value="Subject"/>	Phone contact	<input type="text" value="Contact"/> 
Student's program	<input type="text" value="Program"/>		
Year of the studies	<input type="text" value="Year"/>		
Reason	<input type="text" value="Insert reason"/> 		

 Add attachment

 Cancel  Send

Picture 14 - Student form, Request For Later Submitting Of Final Thesis (source: author)

**User task – Making statement and decision by head of department**

When student finish his request, and send it, new task is assigned to the head of department, in which will student submit his final thesis. Person is notified about this task by email. After that, head of department can see student's request, but he is not allowed to change filled data. Head of department can add his statement in the comment. Then he chooses from 2 options, if the request is approved or refused.

ID	Type
HeadOfDepComment	String
HeadOfDepDecision	Enum

Table 8 - Parameters of the form, head of department (source:author)

ID	Name
----	------

Decision1	Approved
Decision2	Refused

Table 9 - Decision, head of the department (source:author)

Example of this form is in the Picture 15.

Name  Form of the studies

Surname  Address

Date of the birth  Postal code

Student's subject  Phone contact

Student's program

Year of the studies

Student's reason

Student's attachment

Officer's statement

Reason  

Picture 15 - Head of department, Request For Later Submitting Of Final Thesis (source:author)

### User task – Making statement and decision by supervisor

This task is assigned to the supervisor of student's final thesis. Supervisor is notified about task by email. In application, can supervisor add statement using comment. Also, supervisor is making decision about student's request. Same as

in the case of the head of department, supervisor has just 2 options from which he can choose.

ID	Type
SupervisorComment	String
SupervisorDecision	Enum

Table 10 – Parameters of the form, supervisor (source:author)

ID	Name
Decision1	Approved
Decision2	Refused

Table 11 – Decisions of the form, supervisor (source:author)

### User task – Making statement by officer from student’s office

This task is assigned to the officer from student’s office. Officer makes statement by using comment. Officer can see form filled by student, statement of the supervisor and head of department, but form is just for reading. Officer’s statement will be after finishing send to subdean for student’s affairs.

ID	Type	Validation
SupervisorComment	string	required

Table 12 - Parameters of the form, officer (source:author)

Example of the form is in the Picture 16.

Name	<input type="text" value="Name"/>	Form of the studies	<input type="text" value="Form"/>
Surname	<input type="text" value="Surname"/>	Address	<input type="text" value="Address"/>
Date of the birth	<input type="text" value="Date"/>	Postal code	<input type="text" value="Postal code"/>
Student's subject	<input type="text" value="Subject"/>	Phone contact	<input type="text" value="Contact"/>
Student's program	<input type="text" value="Program"/>	Start date	<input type="text" value="Date"/>
Year of the studies	<input type="text" value="Year"/>	End date	<input type="text" value="Date"/>

Student's reason

Student's comment

Student's attachment

Download

View

Officer's statement

Insert statement

Cancel

Send

Picture 16 - Officer, Request For Later Submitting Of Final Thesis (source:author)

### User task – Making statement and decision by subdean for student's affairs

This task is assigned to the subdean for student's affairs. Subdean can see form filled by student, statement and decision of the supervisor, statement and decision of the head of department, statement of the officer, all this information in form just for reading. Subdean can add his statement using comment and make his decision choosing from the options.

ID	Type	Validation
SubdeanComment	string	Required
SubdeanDecision	enum	Required

Table 13 - Parameters of the form, subdean (source:author)

ID	Name
----	------



Decision1	Approved
Decision2	Refused

Table 14 - Desisions of the form, subdean (source:author)

Exemplar of the subdean's form is in the Picture 17.

Name  Form of the studies

Surname  Address

Date of the birth  Postal code

Student's subject  Phone contact

Student's program

Year of the studies

Student's reason

Student's attachment

Officer's statement

Reason  

Picture 17 - Subdean, Request For Later Submitting Of Final Thesis (source:author)

### Service task - Generating document

Document is generated according to the subdean's decision. Decision can be 4 types:

- Request is approved by all required person.

- Request is refused by the supervisor.
- Request is refused by the head of department.
- Request is refused by the subdean for student's affairs.

#### **User task – Printing document and arranging the signs**

Officer has to check generated document. Generated document is sent to officer's email. Then officer can check document and print it. Officer has to handle printed document to the subdean, the supervisor and the head of department to sign it.

#### **User task – Sending of the decision**

This task is assigned to the officer. Officer has to send signed decision by all required person to the student by post. Also, officer has to send decision to the student by email.

### **7.5.2.2 Conclusion of the automatization**

Proposed automatization of the process will significantly save student's time, because student doesn't have to have to handle request to supervisor and head of the department by himself. This is related to KPI time cost. Same like in the previous process, after automatization customer and organization will avoid the mistakes while processing the request, what is related to KPI number of successful executions. And also, automatization help to decrease chance of damaging or losing the request, what is related to KPI information security.

### **7.5.3 Application of key performance indicators**

#### **7.5.3.1 Average duration of the process**

##### **Before optimization**

Average time for duration from the day, when student deliver request to student's office till the end of the point is few days. To duration of the whole process is necessary to add time before delivering request to student office. It includes time, when student fill the form and then give request to supervisor of final thesis and to head of a department, where thesis will be submitted. So, final

time including every step from process can take more than week, while request will go through all required persons.

#### **After optimization**

When we count, the time required for executing the process after automatization, final time will be comparable to the time before automatization. Times of each activities will change, but sum of the all-time remain almost the same. Just time required for student's activities move to activity of the officer, because instead of student, now officer is arranging all the signs.

### **7.5.3.2 Time cost**

#### **Before automatization**

The most critical part is from the view of the student. Student has to arrange all the signs, so it can decrease his satisfaction and it take student's free time. Arranging meeting with supervisor to get the sign and the statement and also with head of the department is time consuming.

#### **After automatization**

After automatization, activities that required time on the side of the student, is significantly decreased. Student save the time, because is not required from him to arrange statements from the supervisor and head of the department by himself. Now all time required from the student is just for filling the form. On the other hand, officer will need more time to execute all activities contained in the process. So, in the end, time will move from the customer to the organization.

### **7.5.3.3 Number of successful executions**

#### **Before automatization**

Number of all request processed during one academic year is tens of request. From this amount of request only a few on them, there is not exact number, is executed with some mistakes. Mistakes that are made by organization or by customer.

#### **After automatization**

After automatization number of mistakes made in request can be minimized to zero. When I requested for later submitting of my bachelor thesis, I requested for

term in September. My request was approved and my deadline was changed to September. But then officer sent me email that there was made mistake and deadline for submitting of my bachelor thesis is earlier, because final exam is held in September. After automatization, when this information will be filled through online form, student can't request for term which is not possible to request and officer can easily notice and correct deadline. Also by online form it will be easier to avoid any mistakes related with filling the form.

#### **7.5.3.4 Information security**

This identificatory of the process performance will behave same like in the case of the previous process. Also, this request is in the present just in the paper form, so values monitored before and after automatization will be comparable to the request for interrupting studies.

#### **7.5.3.5 Customer satisfaction**

##### **Before automatization**

When student wants to request for later submitting of final thesis, he has to manage by himself delivering of request form to his supervisor and head of the department, where thesis will be submitted. Student must make appointment with both of professors, or let form in office of professor's secretary to get statement for his request.

##### **After automatization**

Customer satisfaction will increase significantly, because there will not be required from customer to arrange all the statements by his own. Student's time will be saved, what will lead to more satisfaction than in the present. All what student has to do after automatization is fill the form and wait for the answer.

#### **7.5.4 Conclusion – application of the key performance indicators**

Following table contains evaluation the key performance indicators of the process. Table compares chosen key performance indicator and their values after automatization with the values of the indicators before automatization. Value of the key performance indicator is improved (☺) or the same (☹). It is not

expected to get worse the value of the indicator in the any case, because automatization was focused on these exact indicators and automatization was provide to improve the values of the indicators.

Performance indicator	After automatization comparing to state before
Average duration of the process	☺
Time cost	☺
Number of successful executions	☺
Informational security	☺
Customer satisfaction	☺

*Table 15 - KPI Later submitting of the thesis (source: author)*

Evaluation shown, that values of the time cost, number of successful executions, informational security and customer satisfaction improves, when it is compared with values before automatization. Just in the case of average duration of the process is expectation, that the value stays the same.

## **7.6. Conclusion of the practical part**

I was describing why I chose FEE at CTU for process analysis. I provided review of the beginning of the business process management at the FEE. Setting of the criteria helped me to select the processes for process analysis and optimization.

Firstly, I set the key performance indicators, which were the base for the analysis and optimization. According to the selected KPIs was performed analysis and optimization of the processes, focused on the improving of the chosen characteristic of the processes.

I provided process analysis of the process from the view of process correctness, logical and context correctness, informational system/technologies. Process analysis showed the weaknesses of the process and helped to find potential for improvement of the process with respect to identified key performance indicators. The biggest weakness of the both processes was, that they are not supported by the informational systems from the side of the customer. Then

customer is burdened by paper work and has to handle everything on his own. This can end in student discontent with the services provided by faculty.

Process analysis was followed by optimization of the processes. I suggested automatization of the processes using software tool Camunda. Processes are not changed from the scratch, changes are just related to start of using online forms instead of the paper form and all necessary activities. I described workflow of the process after automatization from the view of all process attendants. In the last step, I applied key performance indicators by comparing values of them before and after automatization.

### **7.6.1 Assets and dangers of the provided automatization**

In this section of the thesis I want to name assets and dangers accrued from automatization of the selected processes. Some of the assets were named, when were measured key performance indicators and their evaluation showed improvement of the process performance.

Assets are:

- Standardization of the workflow of the process.
- Less time required from the customer.
- Lower rate of the mistakes, while executing of the process.
- Easier archiving of the documents.
- Easier providing of the informational security.

Possible dangers, that are important to consider while implementing automatization on the selected processes:

- More time required from the employees while executing the process.
- Discontent of the employees. Standardized activities can also change customs of the employees and change how they are used to work on daily basis.
- Less of the contact between organization and customer.

It is obvious that with the assets always come also dangers. Organization should be aware of all these dangers while implementing automatized processes. Also

after automatization of the processes, performance has to be measured and organization shouldn't stop with improving of the process.

### **7.7. Next steps after project**

If in the future work on my bachelor thesis will continue, it will require some additional steps before using the automatization in the practise. The most important will be to communicate about processes with process owner and other process attendants. This ensure team of analyst, that processes are set correctly and helps to collect more process weaknesses or mistakes.

Before implementing automatized processes is important to prepare employees of the FEE and get them acquainted with software tool and all necessities. Organization has to prepare support and documentation for the customers of the process. Before start of using the automatization, should be also done test and test environment for employees.

After implementing automatization, it will be important to not forget about monitoring and measuring of the key performance indicators. Thanks to these indicators can organization easily watch the performance of the process, evaluate automatization and change something, if it is necessary. It should be useful to ask student and employees to fill the survey and get feedback about automatized process. It will be easier to collect user requirements and implement changes to the processes. Also, surveys for customers can partially compensates contact with organization.

## Conclusion

In this section I will conclude which settled goals were fulfilled and explain assets of the bachelor thesis. In the followed points, I will evaluate 4 goals from the introduction.

1. *Explain term of business process, business process management and process oriented organization.*

In the first and second section were explained all mentioned terms. Business process was defined, also characteristics and goals of the businesses process. Business process management was characterized and compared to the functional management.

2. *Evaluate present state of the business process management and name supporting software tools.*

In the sixth section was described present state of the business process management in the private and public sector. It was difficult to get more information related to the public sector and especially university environment and evaluate it. Then were described tool for graphical representation of processes and also software tool Camunda for process modelling and automatization.

3. *In the chosen organization select process suitable for automatization and perform process analysis of these processes.*

FEE CTU was chosen as an organization for practical part. Criteria were settled for choosing processes suitable automatization. Process analysis was performed on the selected processes, from the views that have meaning for performing optimization.

4. *Propose automatization of the processes using selected software tool, and evaluate automatization using performance indicators.*

Firstly, I chose Camunda as a software tool suitable for process automatization. I proposed automatization of two processes, Request For Interrupting studies and Request For Later Submitting Of Final Thesis, using Camunda. In the Appendix are also the process models of workflows in Camnuda. Suggested automatization is evaluated using performance indicators, which were settled before performing automatization.



Performance indicators shows advantages and disadvantages of the suggested optimization, what will be improved by realizing automatization.

Asset of the bachelor thesis is proposal of the optimization of the processes from FEE CTU. This proposal is the basis for later possible automatization of named processes. If faculty will decide to realise this project, there must be provided more consultations with the owner of the process and with employees, which are attendants of the process. But future team of analysts can use this thesis and complete it about required necessities.

## **Acronyms**

AS-IS – current state

BPMN – Business Process Model and Notation

CMMN – Case Management Model and Notation

CTU – Czech Technical University

DMN – Decision Model and Notation

FEE – Faculty of Electrical Engineering

KOS – study informational system

KPI – key performance indicator

TO-BE – future/expected state

XML – eXtensible Markup Language

## Bibliography

- [1] KUBERA, Ondřej. *Analýza a optimalizace procesů FEL*. Prague, 2012. Master thesis. Czech Technical University. Supervisor Starý Oldřich.
- [2] *Community, Camunda BPM* [online]. [cit. 2017-08-03]. Available from: <https://docs.camunda.org/manual/7.7/>
- [3] CIENCIALA, Jiří. *Procesně řízená organizace: tvorba, rozvoj a měřitelnost procesů*. 1.vyd. Praha: Professional Publishing, 2011, 204 s. ISBN 978-80-7431-044-7.
- [4] *Documents Associated with Business Process Model and Notation™ (BPMN™) Version 2.0*. [online]. [cit. 2017-08-03]. Available from: <http://www.omg.org/spec/BPMN/2.0/>
- [5] GRASSEOVÁ, Monika et al. *Procesní řízení ve veřejném sektoru: teoretická východiska a praktické příklady*. Vyd. 1. Brno: Computer Press, 2008, 266 s. ISBN 978-80-251-1987-7.
- [6] HAMMER, Michael a Lisa W. HERSHMAN. *Rychleji, levněji, lépe: devět faktorů účinné transformace podnikových procesů*. Praha: Management Press, 2013. Knihovna světového managementu. ISBN 978-80-7261-253-6.
- [7] KRYŠPÍN, Luděk. *Ekonomika procesně řízených organizací*. Vyd. 1. Praha: Oeconomica, 2005, 53 s. ISBN 80-245-0965-2.
- [8] Marecek, Jaromír. *Nástroje pro modelování podnikových procesů*. Praha : VŠE, 2010.
- [9] HAMMER, Michael a James CHAMPY. *Reengineering - radikální proměna firmy: manifest revoluce v podnikání* /// [Hammer, 1995]. Přeložil Leo VODÁČEK. Praha: Management Press, 1995. ISBN 80-85603-73-X.
- [10] *MŠMT / IPN KREDO* [online]. [cit. 2017-08-03]. Available from: <http://kredo.reformy-msmt.cz/>
- [11] ŘEPA, Václav. *Podnikové procesy: Procesní řízení a modelování*. 2., aktualizované a rozšířené. Praha: Grada Publishing, 2007, 288 s. ISBN 978-80-247-2252-8.

- [12] ŠMÍDA, Filip. *Zavádění a rozvoj procesního řízení ve firmě*. Praha: Grada, 2007. Management v informační společnosti. ISBN 978-80-247-1679-4.
- [13] HRONZA, Radek. *Procesní portál – od motivace až po současnost* [online]. [cit. 2017-08-03]. Available from: <http://blog.czm-cvut.cz/procesni-portal>
- [14] HRONZA, Radek. *Procesní řízení* [online]. [cit. 2017-08-03]. Dostupné z: <http://blog.czm-cvut.cz/procesni-rizeni>
- [15] ŘEPA, Václav. *Podnikové procesy: procesní řízení a modelování*. 2., aktualiz. a rozš. vyd. Praha: Grada, 2007. Management v informační společnosti. ISBN 978-80-247-2252-8.
- [16] ŘEPA, Václav. *Procesně řízená organizace*. Praha: Grada, 2012. Management v informační společnosti. ISBN 978-80-247-4128-4.
- [17] VÁCHAL, Jan a Marek VOCHOZKA. *Podnikové řízení*. Praha: Grada, 2013. Finanční řízení. ISBN 978-80-247-4642-5.
- [18] PEKÁRKOVÁ, Lucia. *Techniky modelování a optimalizace podnikových procesů*. Brno, 2007. Master thesis.
- [19] *The ISO Survey of Management System Standard Certifications 2015* [online]. 2016 [cit.2017-08-03]. Available from: [https://www.iso.org/files/live/sites/isoorg/files/standards/conformity\\_\\_assessment/certification/doc/survey\\_\\_executive-summary.pdf](https://www.iso.org/files/live/sites/isoorg/files/standards/conformity__assessment/certification/doc/survey__executive-summary.pdf)
- [20] TUČEK, David, Martin HRABAL a Lukáš TRČKA. *Procesní řízení v praxi podniků a vysokých škol*. Praha: Wolters Kluwer, 2014. ISBN 978-80-7478-674-7.
- [21] UČEŇ, Pavel. *Metriky v informatice: jak objektivně zjistit přínosy informačního systému*. 1. vyd. Praha: Grada, 2001, 139 s. ISBN 80-247-0080-8.
- [22] WHITE, Stephen A. *BPMN modeling and reference guide: understanding and using BPMN*. Lighthouse Point, FL: Future Strategies, 2008. ISBN 978-0-9777527-2-0.
- [23] *Process Portal ČVUT* [online]. [cit. 2017-08-03]. Available from: <https://procesy.cvut.cz/bpm/>

- [24] KIM, Alexey. *Analýza možnosti elektronizace podnikových procesů*. Prague, 2017. Bachelor thesis. Czech Technical University. Supervisor Hronza Radek.
- [25] FORMANOVÁ, Petra. *Srovnání možností modelování podnikových procesů pomocí S-BPM s BPMN a UML*. Prague, 2015. Master thesis. Czech Technical University. Supervisor Náplava Pavel.
- [26] *Individuální projekty národní pro oblast terciárního vzdělávání* [online]. [cit. 2017-08-06]. Available from: <http://efin.reformy-msmt.cz/>
- [27] *Procesní portál - Fakulta Elektrotechnická* [online]. [cit. 2017-08-08]. Available from: <https://www.fel.cvut.cz/procesy/about.jsf>

# Appendix

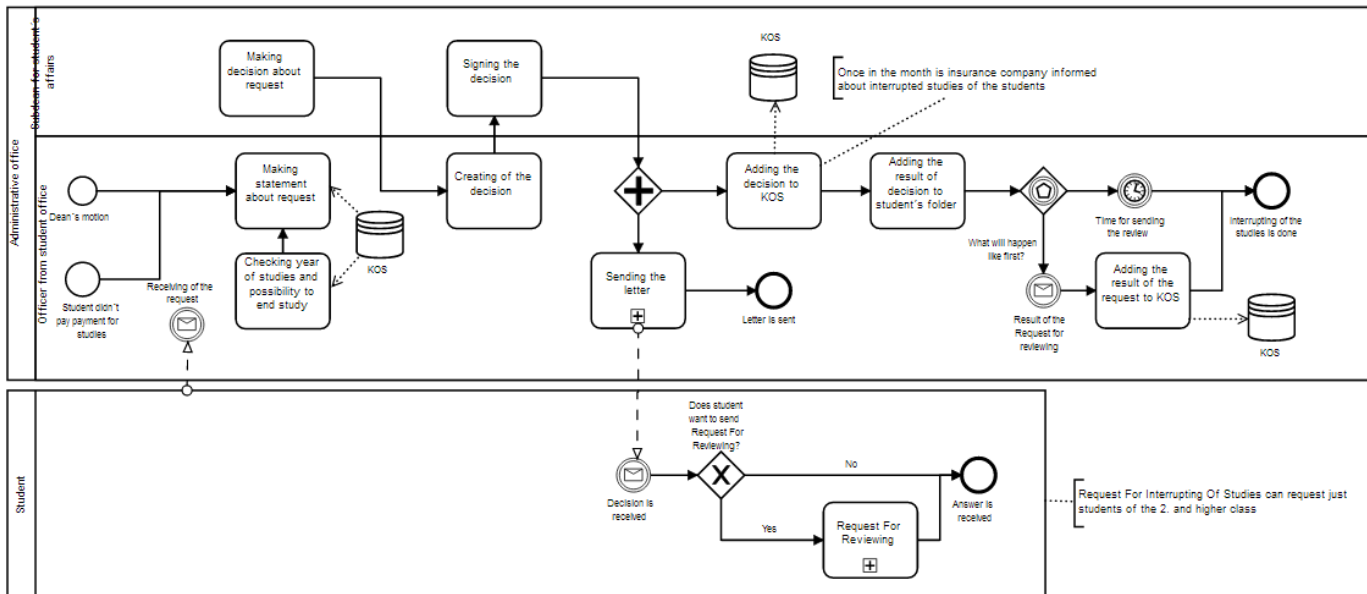

Process 1 - Process For Interrupting Studies (source: translated from [23])

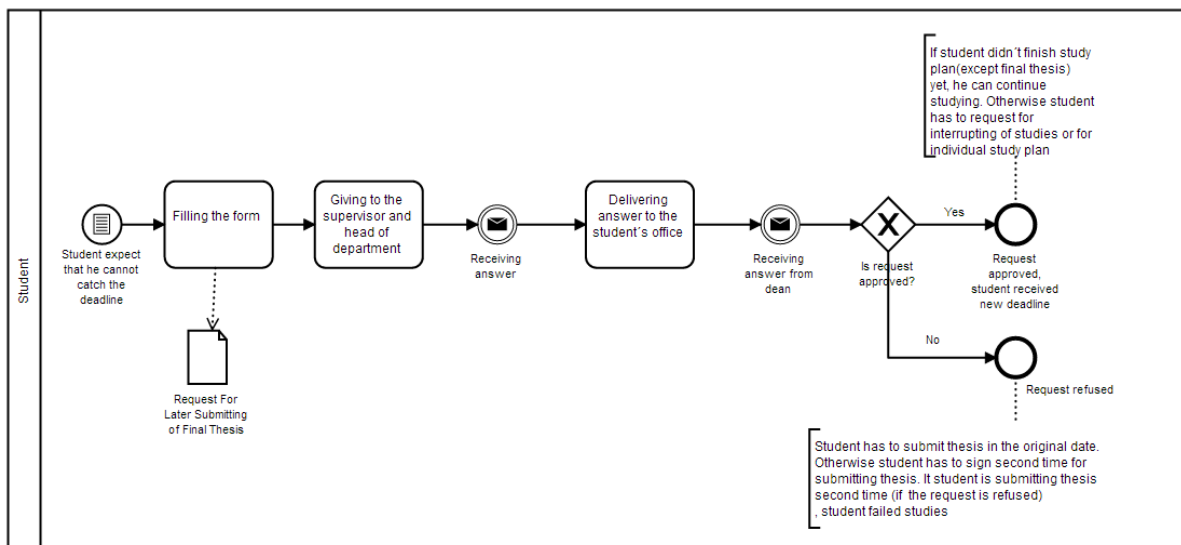

Process 2 - Service Later Submitting Of Process Thesis (source: translated from [23])

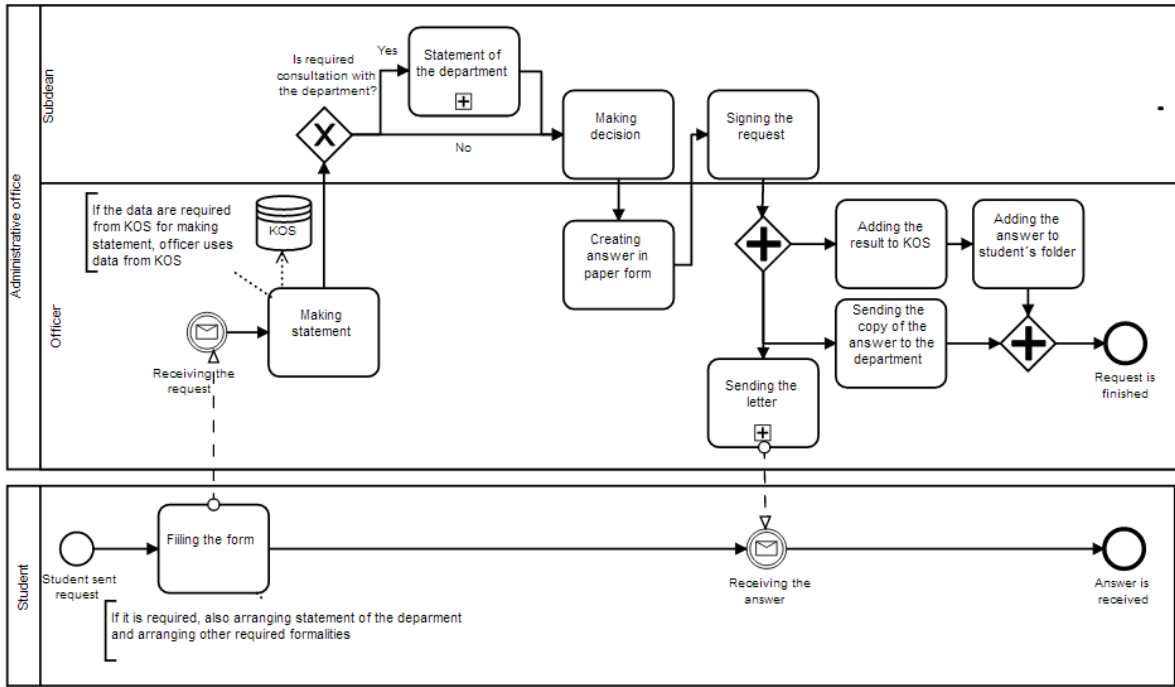

Process 3 - Process of processing general request (source: translated from [23])

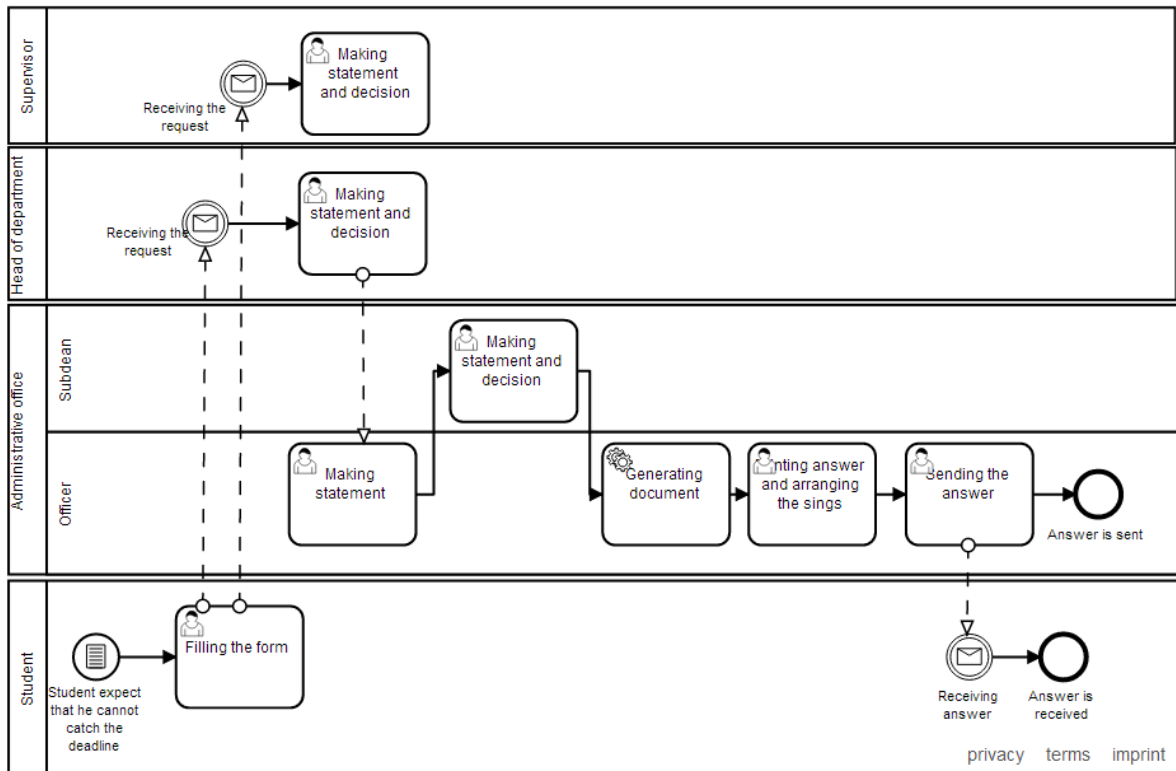

Process 4 - Later Submitting Of Final Thesis, Camunda workflow (source: author)

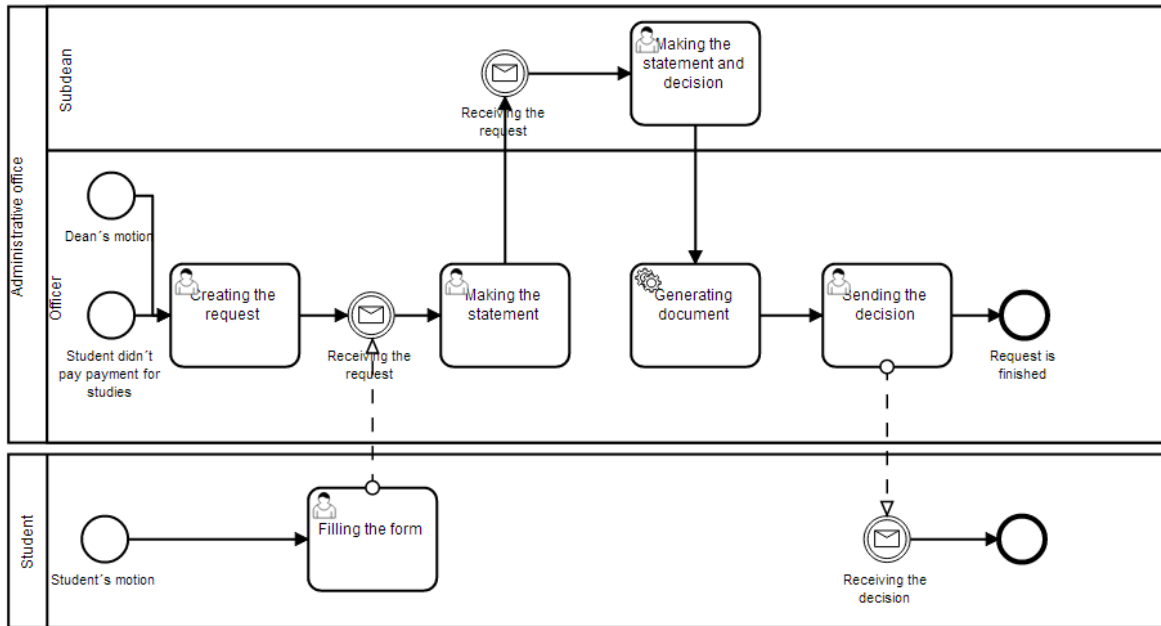

Process 5 - Interrupting Of Studies, Camunda workflow, (source: author)