

ŘEZY NA LISTU 2

Objekt	Objekt	Datum	Průběh	Datum	Průběh	Měřítko
001	001	05.10.2017	PRAHA	05.10.2017	PRAHA	1:5 (1:X)
001	001	05.10.2017	PRAHA	05.10.2017	PRAHA	1:5 (1:X)

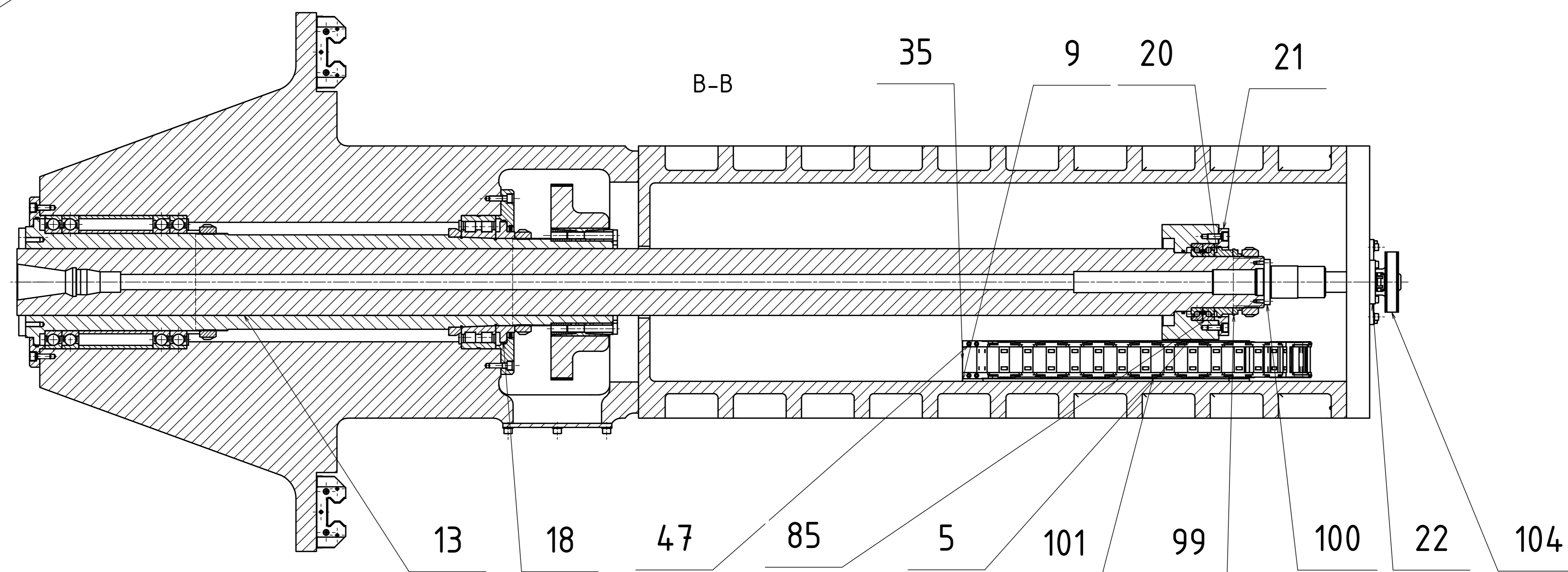
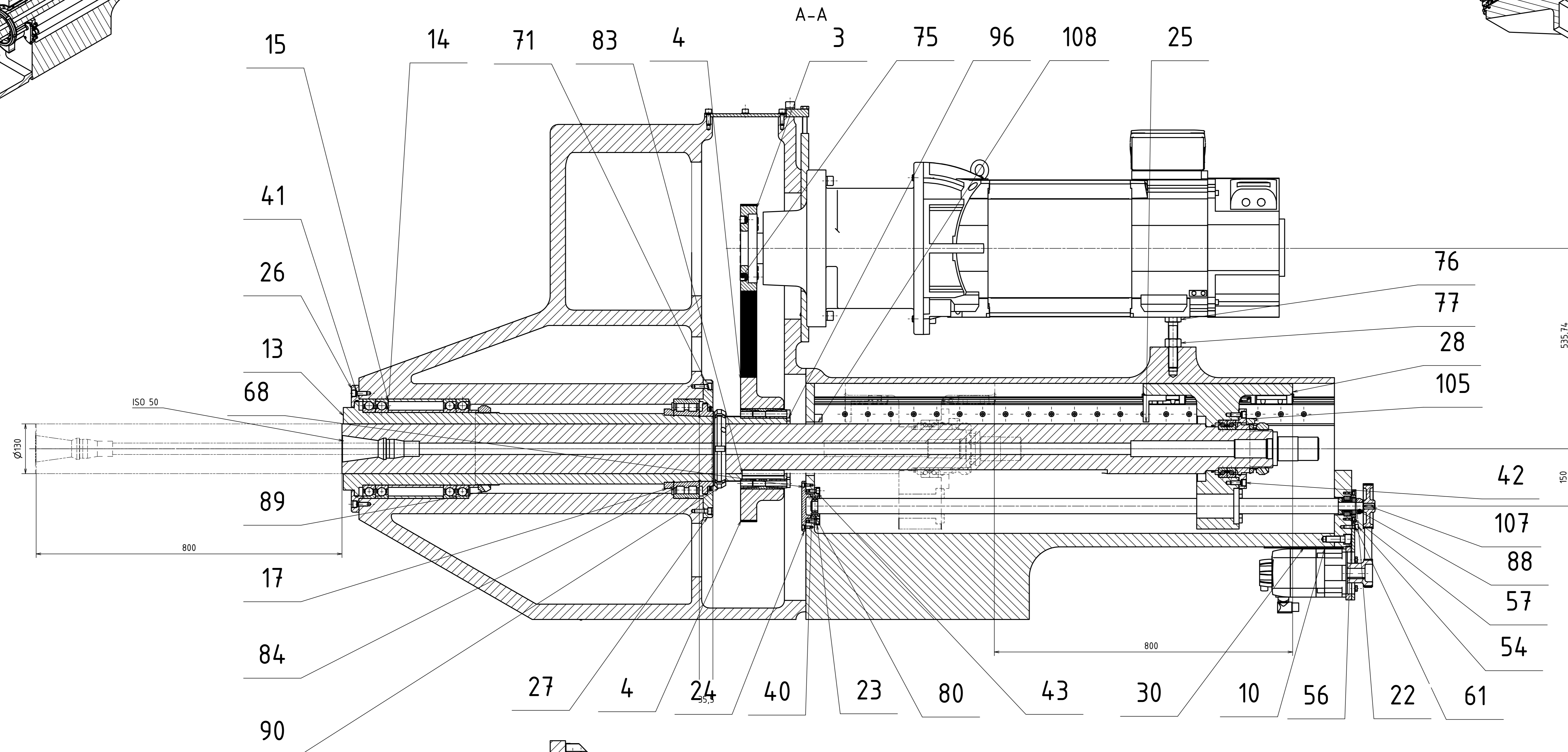
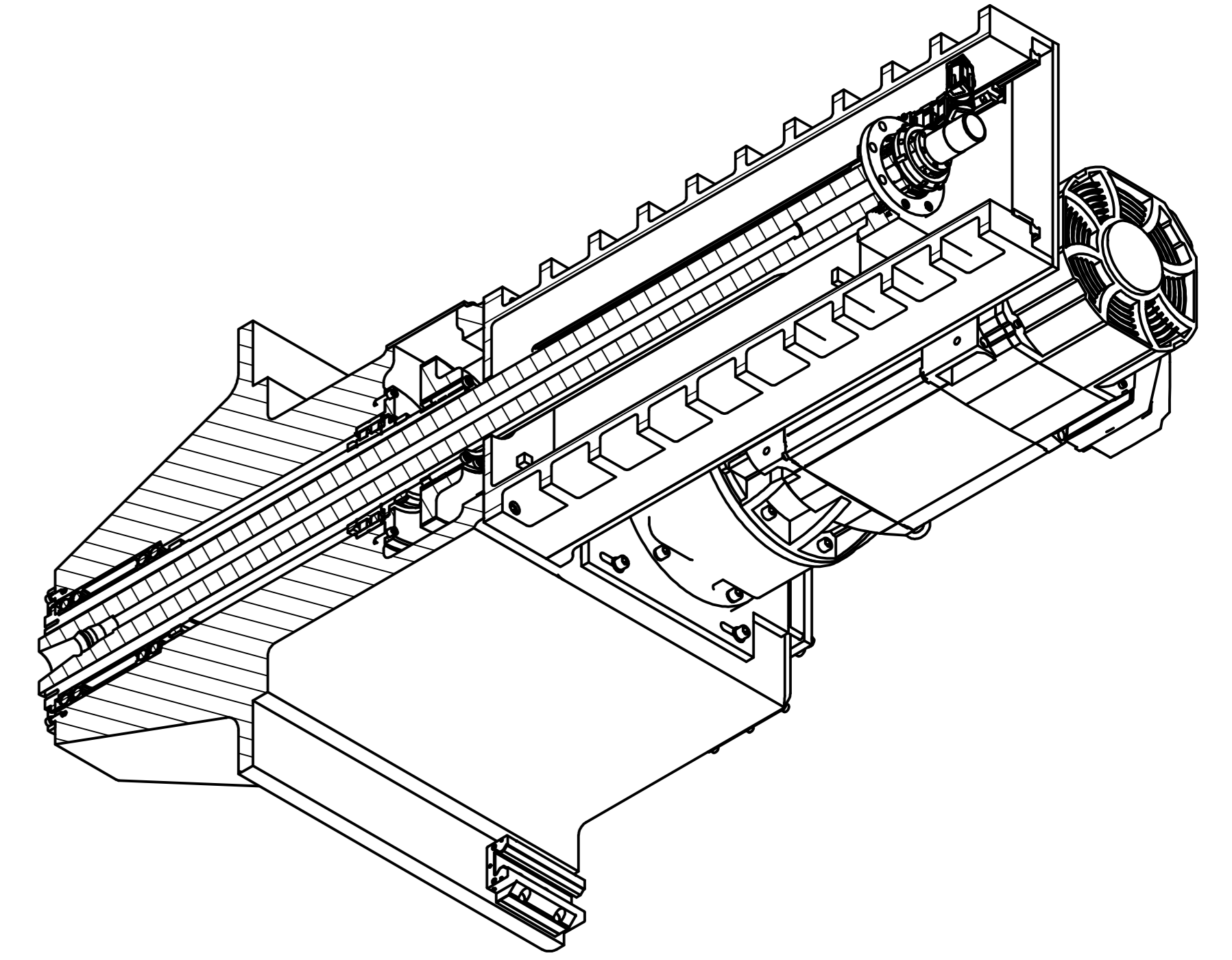
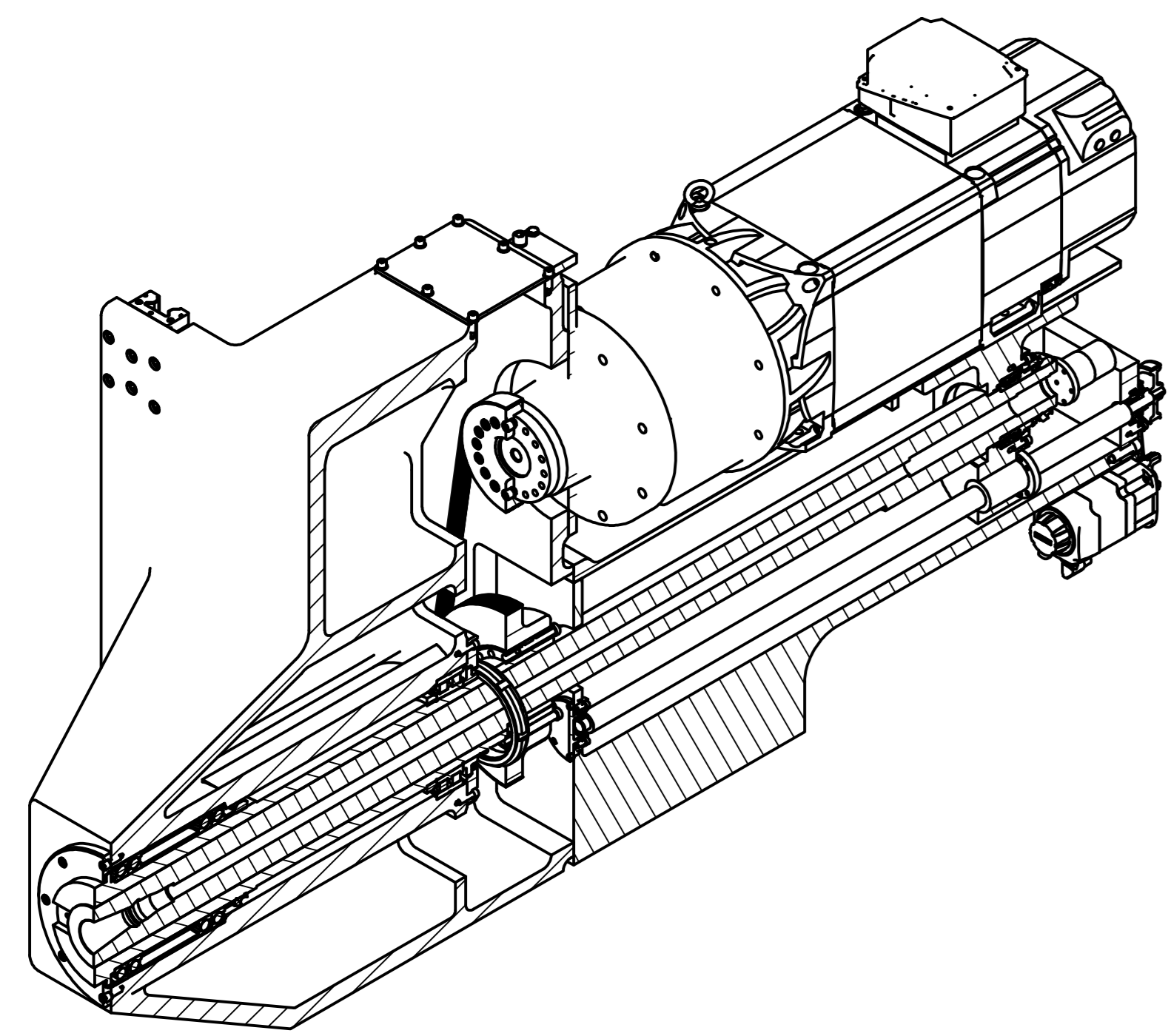

UTAHOVACÍ MOMENTY ŠROUBŮ		
D	R	Mu
mm	mm	N.m
M4	0,7	3,8
M5	0,8	7,5
M 6	1	9,7
M 8	1,25	24,5
M10	1,5	48,4
M12	1,75	84
M14	2	133
M24	3	699