

# PŘÍLOHA 8

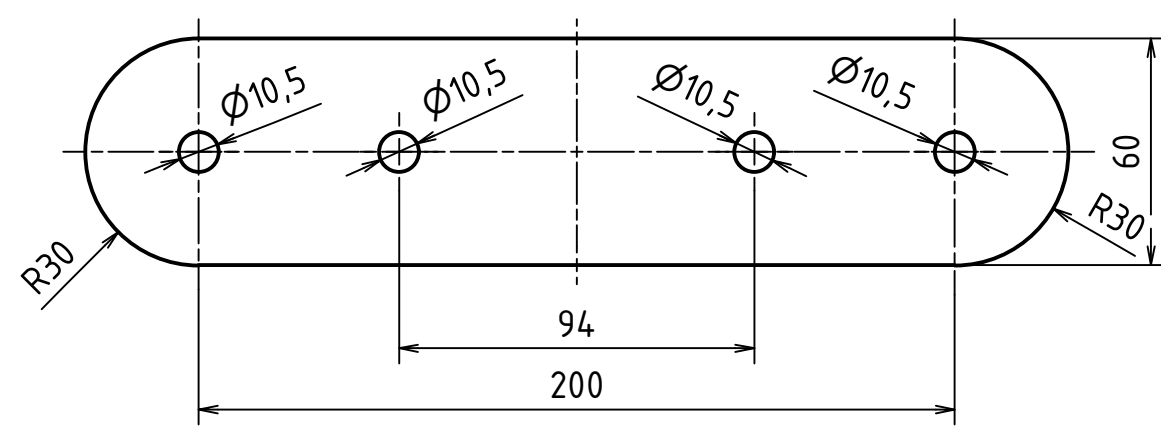

ISO ( 1 : 2 )

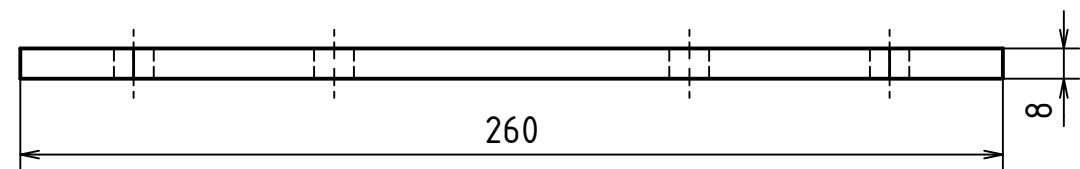
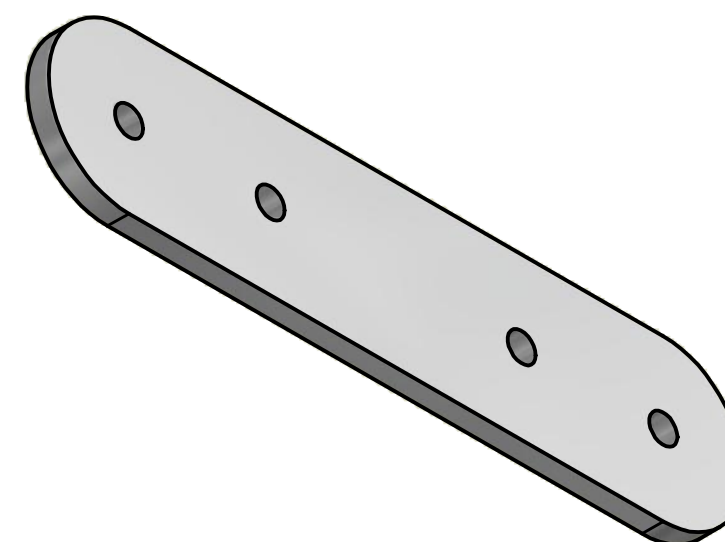

MATERIÁL: Al slitina EN AW 6082 T6																			
POLOTOVAR:																			
TOLEROVÁNÍ DLE ISO 8015																			
PŘESNOST ISO 2768 - mK																			
VŠEOB. TOL. ISO 8062 -																			
		Autor		Datum		Podpis		Datum		HMOTNOST 0,313 kg		INDEX		ZMĚNA		DATUM		PODPIS	
NAVRHL		Černý Marcel		16.11.2016		PŘEZK.				SESTAVA				MĚŘÍTKO		1:2			
KRESLIL		Černý Marcel		14.03.2017		SCHVÁLIL				KUSOVNÍK				PROMÍTÁNÍ: <math>\begin{matrix} \text{---} \\ \text{---} \end{matrix}</math> <math>\begin{matrix} \text{---} \\ \text{---} \end{matrix}</math> (ISO E)					
ČESKÉ VYSOKÉ UČENÍ TECHNICKÉ V PRAZE <b>FAKULTA STROJNÍ</b>				NAZEV				pásek				TYP:							
				ČÍSLO VÝKRESU				ML - 05				LIST: 1 / 1							