

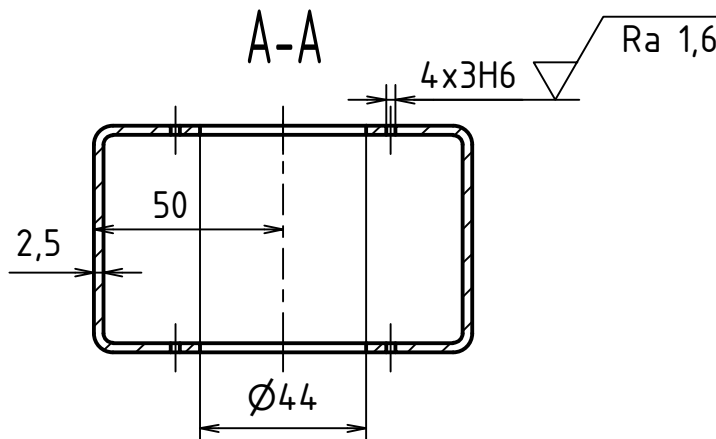

A-A



Ra 3,2 (Ra 1,6)

MATERIÁL: 11 343.0							
POLOTOVAR: TR OBD 100x60x2,5 - 238 CSN 42 6936							
PROMÍTÁNÍ:  (ISO E)							
TOLEROVÁNÍ PODLE ISO 8015: NE							
PŘESNOST ISO 2768 - mK							
Podpis		Datum		Podpis		Datum	
NAVRHL		STATIK		HMOTNOST		1,250 kg	
KRESLIL Martin FRICEK		15. 6. 2015		NORM. REF		Č. SVITKU	
SKUPINÁŘ		PREZK.		SESTAVA BP-0189-00-00-00		KUSOVNIK BP-0189-00-00-00-K	
TECHNOL.		SCHVÁL		STARÝ V.			
				INDEX		ZMĚNA	
				DATUM		PODPIS	

ČESKÉ VYSOKÉ UČENÍ TECHNICKÉ V PRAZE		NÁZEV		TYP:	
FAKULTA STROJNÍ		OBDÉLNÍKOVÝ PROFIL			
		ČÍSLO VYKRESU		BP-0189-00-00-10	