



**CZECH TECHNICAL UNIVERSITY IN PRAGUE**

Faculty of Electrical Engineering  
Department of telecommunication engineering

Bachelor Thesis

**Handover in mobile network with femtocells**

David Blagodárný

Study Programme: Communication, Multimedia and Electronics  
Branch of study: Network and Information Technologies

Thesis adviser: Ing. Robert Bešťák, Ph.D.

Prague, May 2015

## Čestné prohlášení

Prohlašuji, že jsem zadanou bakalářskou práci zpracoval sám s přispěním vedoucího práce a konzultanta a používal jsem pouze literaturu v práci uvedenou. Dále prohlašuji, že nemám námitek proti půjčování nebo zveřejňování mé bakalářské práce nebo její části se souhlasem katedry.

Datum:

.....

## **Anotace:**

Tato bakalářská práce se zabývá předáváním spojení v síti s femtobuňkami. Cílem této práce je navrhnout možné řešení, které by snížilo počet zbytečných předáváníí spojení. Daný problém je řešen nastavením priorit femtobuněk algoritmem, jež predikuje budoucí pohyb uživatelů. Díky tomuto řešení bylo dosaženo lepších výsledků, kdy se u navrhovaného řešení podařilo snížit výsledný počet zbytečných předáváníí spojení.

**Klíčová slova:** femtobuňka, handover, LTE, simulace

## **Summary:**

This bachelor thesis is about handover in network with femtocells. The goal of this thesis is to suggest solution which would lower number of unnecessary handovers. The problem is solved by setting priorities of femtocells by algorithm that predicts future movement of users. Better results were achieved thanks to this solution when proposed solution managed to reduce the number of unnecessary handovers.

**Keywords:** femtocell, handover, LTE, simulation

## Poděkování

Rád bych poděkoval vedoucímu bakalářské práce Ing. Robert Bešťák, Ph.D. za cenné rady, věcné připomínky a vstřícnost při konzultacích a vypracování bakalářské práce.

# Abbreviations

<b>3GPP</b>	<b>3rd Generation Partnership Project</b>
<b>ADSL</b>	<b>Asymmetric Digital Subscriber Line</b>
<b>CSG</b>	<b>Closed Subscriber Group</b>
<b>D2D</b>	<b>Device to Device</b>
<b>E-UTRAN</b>	<b>Evolved Universal Terrestrial Radio Access Network</b>
<b>eNB</b>	<b>evolved Node B</b>
<b>GPS</b>	<b>Global Positioning System</b>
<b>HeNB</b>	<b>Home evolved Node B</b>
<b>HPLMN</b>	<b>Home Public Land Mobile Network</b>
<b>HSS</b>	<b>Home Subscriber Service</b>
<b>IP</b>	<b>Internet Protocol</b>
<b>ISP</b>	<b>Internet Service Provider</b>
<b>LTE</b>	<b>Long Term Evolution</b>
<b>M2M</b>	<b>Machine to Machine</b>
<b>MME</b>	<b>Mobility Management Entity</b>
<b>MSC</b>	<b>Mobile Switching Centre</b>
<b>QoS</b>	<b>Quality of Service</b>
<b>RSSI</b>	<b>Received Signal Strength Indication</b>
<b>S-GW</b>	<b>Serving Gateway</b>
<b>TAN</b>	<b>Temporary Area Network</b>
<b>UE</b>	<b>User Equipment</b>
<b>VPLMN</b>	<b>Visited Public Land Mobile Network</b>

# Contents

<b>1</b>	<b>Introduction</b>	<b>1</b>
<b>2</b>	<b>Informations about femtocell network</b>	<b>2</b>
2.1	What is a femtocell? . . . . .	2
2.2	Femtocell network architecture and interfaces . . . . .	4
2.3	Overview of handover . . . . .	6
2.4	Handover scenarios in femtocell network . . . . .	9
<b>3</b>	<b>Avoiding unnecessary handovers</b>	<b>11</b>
3.1	Handover information acquisition . . . . .	11
3.2	Handover decision making . . . . .	13
3.3	Handover process . . . . .	15
3.4	Handover in 5G networks . . . . .	16
<b>4</b>	<b>Description of simulation</b>	<b>17</b>
4.1	Model of city for simulation . . . . .	17
4.2	Placement of FAPs and their signal ranges . . . . .	19
4.3	Mobility model . . . . .	21
4.4	Handover scenarios . . . . .	26
<b>5</b>	<b>Simulation results and discussion</b>	<b>29</b>
5.1	Parameters $\alpha$ and $\beta$ . . . . .	29
5.2	Comparison of scenarios . . . . .	32
5.3	Parameter $\gamma$ . . . . .	35
<b>6</b>	<b>Conclusion</b>	<b>37</b>
	<b>Bibliography</b>	<b>38</b>

# List of Figures

2.1	Basic explanation of femtocells. . . . .	3
2.2	E-UTRAN architecture with femtocells [4]. . . . .	4
2.3	LTE femtocell architecture with dedicated FAP-GW [7]. . . . .	5
2.4	Basic explanation of handover. . . . .	6
2.5	Messages flow diagram of handover procedure [4]. . . . .	8
2.6	Basic types of handover in femtocell network. . . . .	10
3.1	Example of handover using location priority. . . . .	13
3.2	Basic handover decision scheme using time threshold value. . . . .	14
4.1	Basic structure of model. . . . .	17
4.2	Complete model of city with main roads. . . . .	18
4.3	Model with 100 % of FAPs available. . . . .	19
4.4	Model with 60 % of FAPs available. . . . .	19
4.5	Signal ranges of FAPs. . . . .	20
4.6	Generation of users. . . . .	21
4.7	Naming of directions. . . . .	23
4.8	Probability in first step. . . . .	23
4.9	Probability to change direction criterion. . . . .	24
4.10	Probability in main road. . . . .	24
4.11	Probability in scenario A. . . . .	26
4.12	Probability in scenario B. . . . .	27
4.13	Probability in scenario C. . . . .	28
5.1	Ratio of movement ( $k_r$ ) in main roads ( $\alpha$ ) to back streets. . . . .	30
5.2	Main road for $n = 2$ . . . . .	30
5.3	Main road for $n = 3$ . . . . .	30
5.4	Back street for $n = 2$ . . . . .	31
5.5	Back street for $n = 3$ . . . . .	31
5.6	Average number of passed crossroads. . . . .	32
5.7	Average number of dropped calls. . . . .	33
5.8	Average number of dropped calls due to wrong decision. . . . .	34
5.9	Average number of handovers. . . . .	35
5.10	Average number of dropped calls for various $\gamma$ . . . . .	36

# Chapter 1

## Introduction

Over the last couple of years mobile traffic has increased dramatically and it is predicted it will grow even faster. Thus demands for high speed networks rise. Best way how to achieve it is to create a large number of new cells with small area of coverage. But it will result in higher expenses for mobile operators and their revenues are every year lower. Therefore new approaches are needed and femtocells could be one of them. But before femtocells can be deployed in large scale many issues must be resolved, including handover.

Hence, aim of this bachelor thesis is to discuss and propose solutions for handover in femtocell network. Most discussed scenarios are where network predicts movement of users and then chooses target cell for handover based on this prediction. Therefore in this thesis a model of part of the city with users is created. Proposed handover scenarios with movement prediction are simulated in this model, and afterwards compared with traditional handover scenario without movement prediction.

What is femtocell and how it is connected to the network is explained in the first chapter. Followed by basic description of handover in femtocell network and types of it. Next chapter contains various proposed scenarios which show many approaches on this subject. These two chapters have more theoretical character. Third chapter describes used simulation and proposed scenarios. Simulation results with all graphs are contained in the last chapter.



# Chapter 2

## Informations about femtocell network

### 2.1 What is a femtocell?

Femtocells are low-power cellular network access points that connects to the mobile service provider's network via user's broadband connection, such as ADSL (Asymmetric Digital Subscriber Line), cable or optical fiber and use licensed spectrum. In most cases data to and from the femtocell are carried over the internet. Typical coverage area of a single femtocell is in order of tens of meters.

One of the main role of femtocells is to provide indoor coverage in places where macrocells cannot, or it would be economically unprofitable. In places with high density of subscribers femtocells help offload traffic from the macro-cell network. Mobile operators can also improve capacity or throughput of their networks with much lower costs in comparison with macrocells. Subscribers can benefit from improved coverage that is also connected with better battery life of user devices or improved bandwidth of connection that enable using data hungry real time services such as high definition video streaming [1].

Figure 2.1 illustrates that femtocells can either overlay macrocell network or extend it, and are usually connected to operator's core network through internet. FAP is abbreviation for femtocell access point.

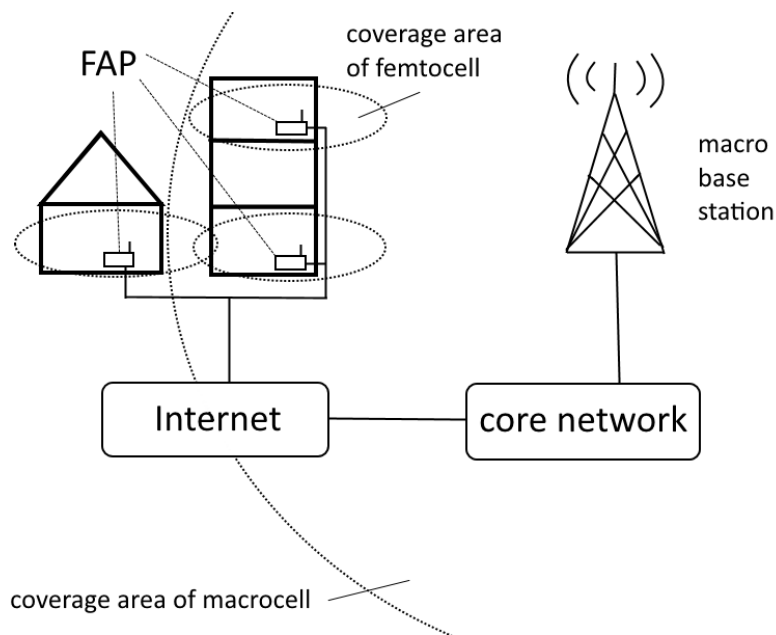

Figure 2.1: Basic explanation of femtocells.

A single femtocell provides services for only a limited number of users. Basic residential femtocells deliver 4-8 simultaneous voice calls and enterprise femtocells up to 16. It can be configured in three operating modes [2].

In first mode called closed access mode or CSG (Closed Subscriber Group) mode provides services only to those users who are included in the femtocell access list and are allowed to use the femtocell. But if many femtocells with this operation mode would exist, they would cause interference with macrocell with almost no positive effect for macrocell network. Thus operators are trying to avoid using femtocells with closed access mode.

Another option is open access mode, it means that anyone who is in range of femtocell can connect to it. This type of access is preferable for operators but not users, because users allow foreign people to connect and use their own broadband they pay for. It is even possible that sometimes users cannot connect to their own femtocell, because all available slots are already in use by other foreign people.

There is also third alternative called hybrid access mode. When users on access list are not using full bandwidth, then available bandwidth is used by users which are not included in access list. This mode combines advantages of other two modes, but with hybrid access is associated problem how to correctly choose handover target, because during handover network does not know exact bandwidth that is available for users not on the access list. For example, if bandwidth would be low, it could lower quality of service or even

break connection when using data hungry services. However in this thesis this issue will not be discussed. More information on this subject can be found in [3].

## 2.2 Femtocell network architecture and interfaces

Femtocell network is an extension of the macrocell network for end-user terminals, therefore it is very important for femtocell network to work together with macrocell network without any problems. One of the crucial feature of femtocell network is connection to operator's core network through internet. Internet is an open network thus operators have to make connection to their closed network as secure as possible. Femtocell security gateway role is to secure connection from internet and to separate secured network of mobile operators from the internet.

The problem of maintaining QoS (Quality of Service) is also connected with internet connection because operators cannot supervise or interfere to internet traffic. For example latency is much bigger than in their own network because it depends on ISP (Internet Service Provider) and used connection technology. Therefore operators must prepare their network to deal with all kind of these problems. It is very complicated issue, hence femtocell standards in LTE (Long Term Evolution) has not been finalized and still need further development.

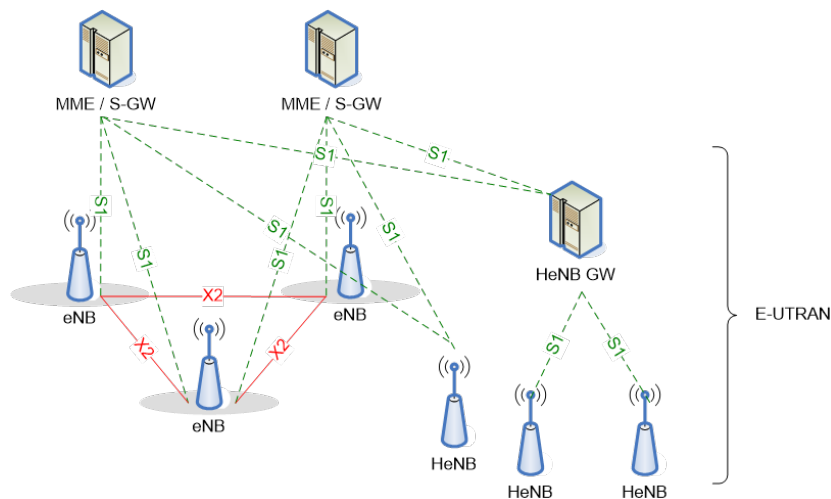

Figure 2.2: E-UTRAN architecture with femtocells [4].

The MME (Mobility Management Entity) deals with the control plane. It handles the signaling related to mobility and security. The MME is also responsible for the tracking and the paging of UE (User Equipment) in idle-mode. The S-GW (Serving Gateway) deals with the user plane. Transport the IP (Internet Protocol) data traffic between the UE and the external networks. The S-GW is also the point of interconnect between the radio-side and the core network of operator. The HSS (Home Subscriber Server) is basically a database that contains user-related and subscriber-related information. It also provides support functions in mobility management, call and session setup, user authentication and access authorization [5].

As can be seen in figure 2.2, in E-UTRAN (Evolved Universal Terrestrial Radio Access Network) architecture 3GPP (3rd Generation Partnership Project) specified two standard interfaces. X2 provides exchange of information between multiple eNodeBs (macro cell base stations). S1 interface supports connection between MME/S-GW and eNodeB. It is also used between FAP and MME/S-GW. In LTE-Advance systems compared to 2G and 3G networks handover can be carried out only between FAPs without assistance of MME, using X2 interface [6].

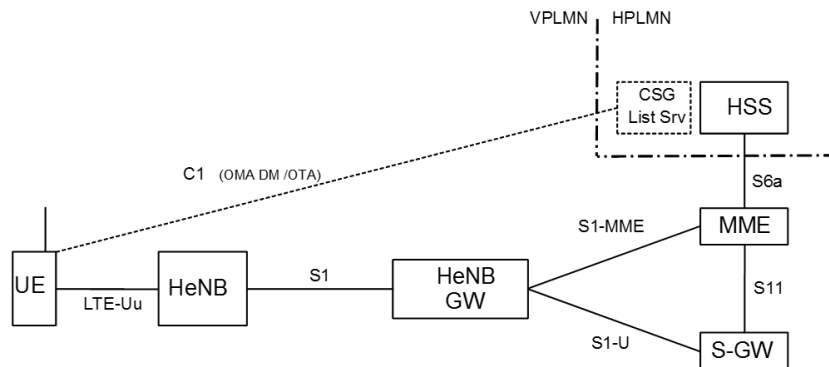

Figure 2.3: LTE femtocell architecture with dedicated FAP-GW [7].

3GPP created special terminology for basic elements of femtocell network. Femtocell access point (FAP) is in UMTS networks called Home NodeB (HNB) and in LTE networks Home eNodeB (HeNB). Femtocell access point gateway (FAP-GW) is in UMTS called Home NodeB Gateway (HNB-GW) and in LTE Home eNodeB Gateway (HeNB-GW). In this text are used popular and well-known terms as FAP or FAP-GW. But in figures from 3GPP their terminology is used.

## 2.3 Overview of handover

Basic purpose of handover is to reconnect from one cell to another when is needed mostly when user is moving. Handover should be able to provide seamless connection to retain high quality of communication. Otherwise it could cause problems to some types of services where continuous traffic is needed.

Usually handover is conducted when UE is moving away from coverage area of current cell and signal strength level is too low to maintain sufficient service quality. Figure 2.4 explains situation when signal strength of current cell drops below target threshold level and handover procedure starts. But handover is not instantaneous and during this procedure signal strength can get below level when service quality is not ensured. Therefore it is very important to achieve time of handover as low as possible. Faster handover also lower traveled distance during handover for moving UE.

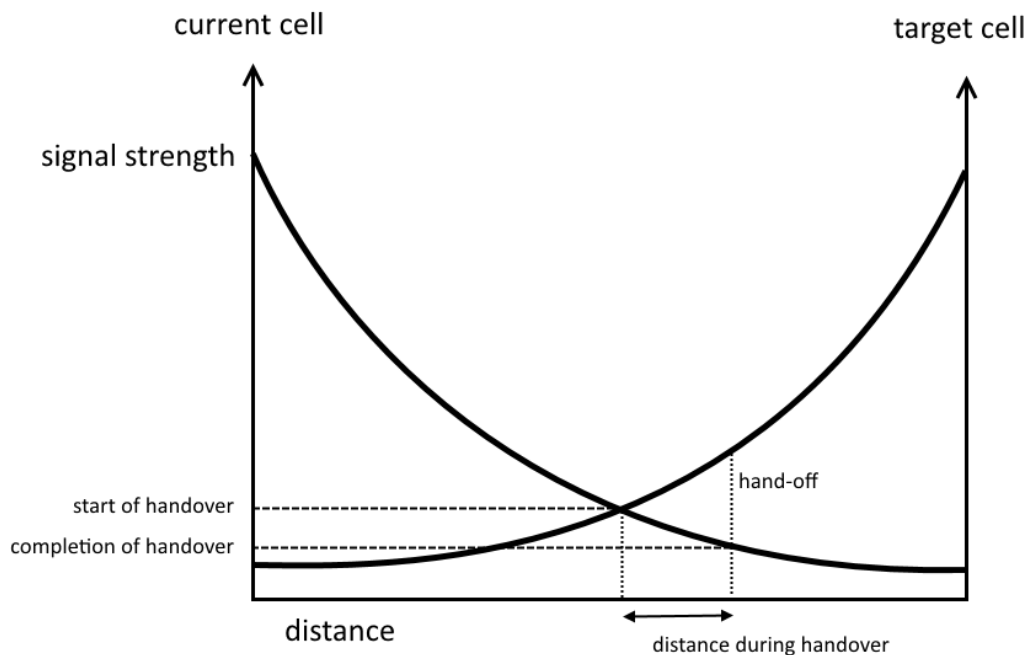

Figure 2.4: Basic explanation of handover.

Handover techniques in mobile communication systems can be divided in two categories: hard handover and soft handover. Hard handover is a break-before-make method. It means that a new connection with the target cell is set up after the release of the connection from previous cell. Hard

handovers should be instantaneous in order to minimize the disruption of the communication. Soft handover is a make-before-break method. Thus source cell releases connection after the connection with new cell is established. Due to limited frequency bands it is not worth of implementing soft handover in femtocell network [8].

In order to simplify explanation, handover procedure can be divided into three parts: the handover measurements, the handover decision and handover execution. In handover measurement phase UE scans neighbor cells and also monitors the signal quality of serving cell. At the beginning of each frame UE is transmitting measured signal strength value to serving cell. When signal strength value of serving cell is below threshold then occurs the handover decision phase. During this phase UE scans signal quality of neighbor cells and then sends reports to serving cell. If certain required criteria are met then follows the handover execution phase. Target cell initiates connection with UE and becomes the serving cell. This procedure is explained in figure 2.5.

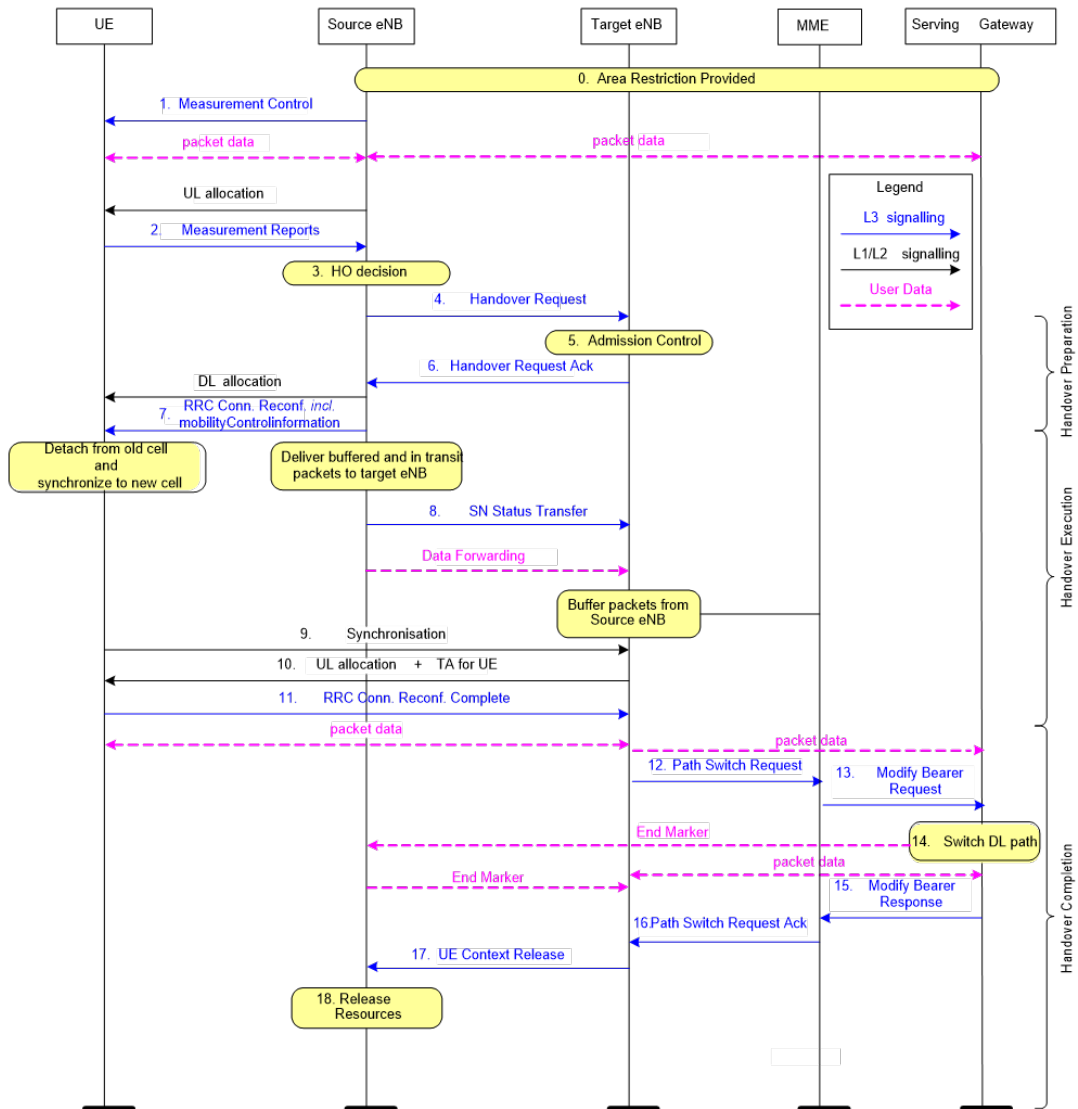

Figure 2.5: Messages flow diagram of handover procedure [4].

Messages flow diagram of handover procedure in figure 2.5 can be described in separated phases. At the beginning, UE is constantly sending measurement reports (2) to source cell. When source cell gets report with greater decision-making value, for example RSSI (Received Signal Strength Indicator), then handover preparation phase starts. During this phase source cell sends handover request (4) to target cell which has stronger signal. Tar-

get cell confirms request and sends back acknowledgement (6). Then source cell sends handover command (7) to UE to detach from old cell and connect to new one. Afterwards synchronization messages (8-10) are sent to complete connection to target cell. This phase can be called handover execution. Last phase is handover completion in which messages to confirm and change path (11-16) are sent. In the end source cell releases radio resources (17-18) to complete handover process [9].

## 2.4 Handover scenarios in femtocell network

During a handover the network must know the identity of target cell in order to prepare it for incoming handover. In the femto-to-macro handover case this can be easily done by extending the neighbor list to include not only the radio characteristics of the neighboring macro cells but also their full identity, such as if it is femtocell or macrocell.

However in the macro-to-femto handover case, it is impossible for the macro cell to know the identity of target femtocell. Potentially, hundreds of femtocells can be in the area covered by only one macrocell. When macrocell would know about every femtocell in the area, it would be an extremely challenging to provide handover fast enough to ensure seamless connectivity.

Nowadays, mobile network operators have given higher priority to femto-to-macro handovers because their macro network is reliable and ensure good service quality, even though FAP signal strength is still good enough. However, this is only a temporary state that operators are willing to accept in order to speed up their femtocell deployment. But in the long run this situation is unsustainable, therefore new approaches for handover in femtocell network are needed.

In femtocell network handover three basic types of handover can occur, as is illustrated in figure 2.6. First is hand-in procedure, which is from macrocell to femtocell. Second is opposite to hand-in, it is from femtocell to macrocell, also called hand-off. Last type of these three is Inter-FAP procedure between femtocells. This handover is very similar to hand-in, because users are being connected to FAP and network has to choose from plenty of possible target FAPs.



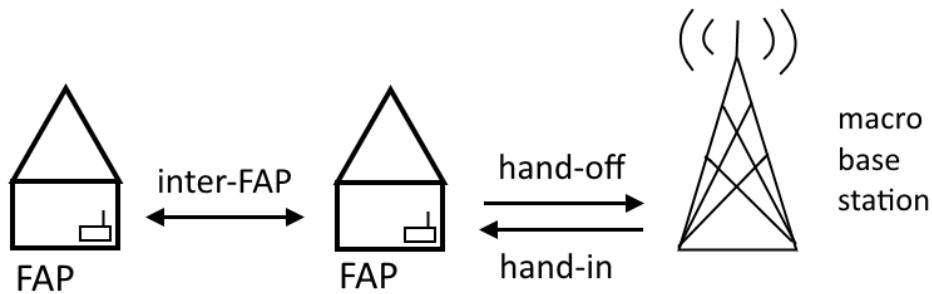

Figure 2.6: Basic types of handover in femtocell network.

### 2.4.1 Hand-in procedure

Macrocell to femtocell handover is one of the most challenging issue for femtocell network. There is not only decision whether choose macrocell or femtocell, but also in choosing right FAP among many others. In highly populated areas FAPs can be deployed in thousands, and if classic handover procedure from macrocell network would be applied, the neighbor list of all available FAPs would be too long and demands on system resources would be enormous. Thus hand-in procedure is a critical element for flawless function of femtocell network. Therefore many new ways how to achieve it are discussed.

### 2.4.2 Hand-off procedure

Handover from femtocell to macrocell is called hand-off. While hand-in procedure is challenging and needs further research, hand-off procedure is quite simple. Because when UE is measuring signal strength to perform handover to most suitable cell, it has to choose from only a few cells. Typically one or two, and simply choose the one with stronger signal. This type of handover is very similar to handover between macro cells.

### 2.4.3 Inter-FAP procedure

Inter-FAP represents interaction between two FAPs. The inter-FAP procedure is very similar to hand-in procedure because in both scenarios handover targets must be chosen from plenty of FAPs. Both the source and target cell have to be in proximity of each other and are usually connected to the same network, therefore compared to hand-in procedure another approaches can be applied.

# Chapter 3

## Avoiding unnecessary handovers

### 3.1 Handover information acquisition

In many areas, such as highways, femtocell are not needed because of their very small coverage areas. However in areas as cities where big quantities of residential and office buildings are, femtocells can help offload traffic from macrocell and are very useful. Thus it is advantageous to deploy them in large numbers.

But it takes some time to realize handover and when mobile user is moving then it is possible that at the moment when he reconnect to target cell, he will be out of coverage range and another handover back to macrocell will be needed. This unwanted so-called ping pong effect will cause wasteful load in network or can even cause short failures in connection.

Before handover, network has to decide whether do handover and which target cell is the best option. Therefore network should acquire all information that can help to decide the best handover target. In basic approach UE measures signal strength and sends results to current serving cell and handover is triggered when certain criteria are met. But in femtocell network it is not enough to correctly decide best handover target.

Few authors [10] focus on estimating location of FAPs and trajectories of UEs to reduce neighbor lists and choose best handover target for UE. Every FAP estimates its location by signal strength from at least three macrocells. It uses assumption that network already knows location of each macrocell. When locations of FAPs are roughly determined then can network estimate the location and trajectory of UE only from measured signal strength without

the assistance of other external systems such as GPS. UE is periodically sending measured signal strength of all cells within reach to serving cell. Hence serving cell is able to continuously monitor position and velocity of all UEs which are connected to it.

Thanks to all these acquired data, serving cell can choose best possible handover targets for each associated UE. Therefore UE does not have to scan all cells within range, but only the cells that are advantageous and chosen by serving cell. It results in smaller neighbor lists, thus reducing time to obtain all these data. But if user would quickly change direction, it takes some time to create new neighbor list and for users with high velocity, dropped calls may occur. Also signal strength value can be affected by various obstacles therefore location can be sometimes determined incorrectly.

One of the option that could be easily deployed is creating a list of all UEs in target small area with priorities for each FAP, and using special interface between FAPs compare these lists. This interface could use dedicated channel for femtocell broadcast. It would lower handover duration time because it would not need to use slow and unreliable backhaul via public internet all the time.

Periodical creation of these lists for each FAP and comparison of them afterwards is proposed in [11]. If any UE is in more than one list, it will be erased from all list, except the one with biggest priority. Then if UE is served by another FAP than by one that has it on the list, handover will be performed. Disadvantage of this solution is a need to create special interfaces between FAPs, thus operators would have to sacrifice part of their highly valuable frequency bands for this interfaces.

Another approach is to monitor previous handovers of target FAP and then predict most used routes and set priorities for handover to FAPs based on these results. To FAPs where UEs stay in their range often only for a very short time a low priority would be given and vice versa. This approach could be theoretically very useful because majority of users follows the same routes, for example main roads. In the cities buildings and roads usually creates almost periodical patterns and this approach could use this fact in its favor. To achieve it, every FAP could periodically send most used handover targets through multicast messages to other FAPs. And if in the neighbor list would appear FAPs with very similar signal strength, network will choose the one with higher priority.

A basic example how this approach can reduce number of unnecessary handovers is in figure 3.1. Defined specific route can be main road with greatest probability that users will be using this road. If this approach would

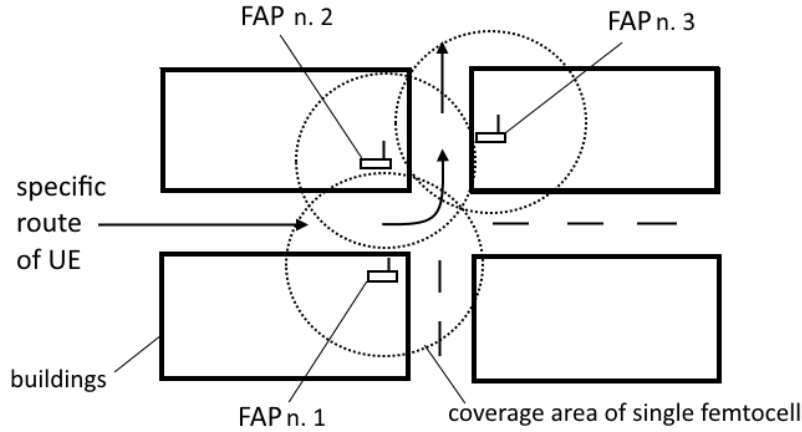

Figure 3.1: Example of handover using location priority.

not be applied, first handover is from FAP n. 1 to FAP n. 2. Because when UE is leaving coverage area of the first FAP, FAP n. 2 has stronger signal than the FAP n. 3. After a while next handover from second FAP to third one is conducted. But if in first step handover to FAP n. 3 would be instead, it could be possible to avoid any interaction with the second FAP and it would save system resources thanks to lower number of handovers.

### 3.2 Handover decision making

Handover policies are the crucial element that has greatest importance on flawless handover procedure. Thus it is important to define when specific handover procedures should occur. For example, if too low signal strength threshold value is chosen, probability of disconnections and unavailability of service is much higher. For handover in femtocell network it is even more important, therefore it is one of the most discussed topic where a lot of new decision criteria are proposed.

One of the most discussed policy is to differentiate static (or with low velocity) UEs from moving to avoid frequent handovers and the associated ping-pong effect. Typical femtocell coverage area is in order of tens of meters. When UE is moving, it stays in the range of selected FAP only for couple of seconds therefore for moving UE is handover to FAP completely unnecessary. It leads to waste of radio resource and has no advantage for macrocell. It would be more suitable, if during handover UE has to be in the range of

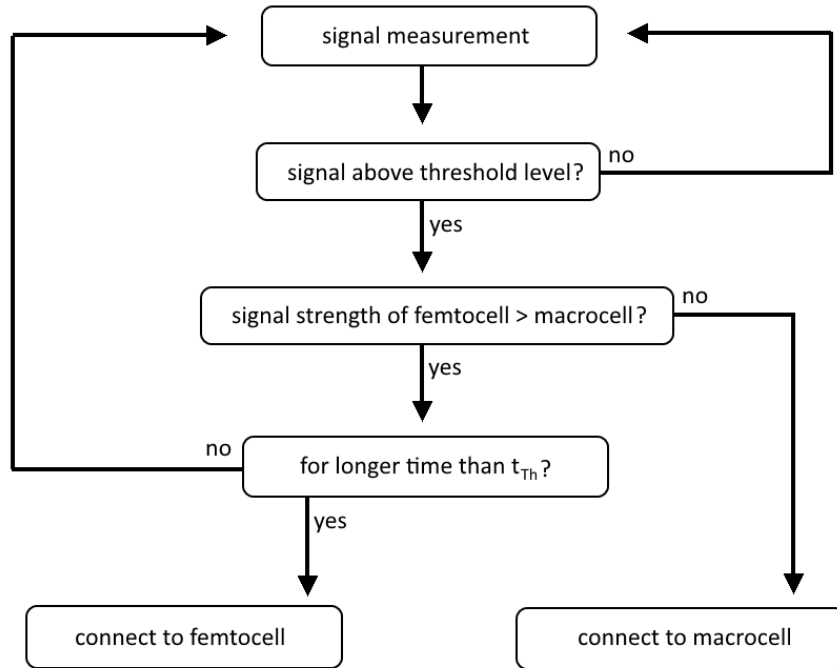

Figure 3.2: Basic handover decision scheme using time threshold value.

target FAP for some time to decide whether UE is moving or not. And if the time is longer than threshold value set by network then handover process to FAP can start. Setting correct threshold value is one of the easiest way how to separate moving UEs from static.

Figure 3.2 shows basic handover decision scheme using time threshold value. Before handover a signal strength is measured and when signal strength of target cell exceeds defined signal strength value then handover procedure is initiated. If the signal strength level is lower than required then UE stays within current cell and measuring process continues. But if the signal strength level is higher, then it compares whether signal strength of FAP is greater than signal strength of macrocell. When macrocell signal strength is greater, normal handover procedure continue to target macrocell. Main difference is when FAP signal strength is greater. Because then network has to decide whether user is moving or not.

As written before, easiest way how to accomplish this is to set threshold time value. It means that signal strength is measured for defined threshold time. If all previous decision conditions are fulfilled for this period of time then handover procedure to FAP can finally start. This condition occurs when user stays in target area for longer time. Usually in office, home or

in shopping centers where the greatest need to offload traffic from macrocell network is. However this condition does not enable handover for moving targets, therefore should be used only in combination with other methods which also take care of moving targets.

Using hysteresis margin (dB) in leaving conditions or entering conditions for handover to delay it is proposed in [12]. Basically, it is adding or removing target defined value to signal strength to lower number of handovers. In networks with only macrocells this margin is useless but with increasing number of femtocells or other small cells it could dramatically lower number of unnecessary handovers. Mainly because signal strength is not monotonically increasing/decreasing and with high number of deployed FAPs which have small area of coverage, number of handovers would rapidly increase without using something such as hysteresis margin.

For instance, when users are gradually passing through three femtocells but the one in middle is not necessary for maintaining sufficient quality of connection. When correct offsets for each FAP is set, users can skip this FAP thus lower number of unnecessary handovers. This offset can also dynamically reflect load of target femtocell. Femtocells with higher load will have higher offset than femtocells with lower load. This feature could be very usefully to avoid overloaded femtocells when it is possible.

Because femtocells have very small area of coverage, this approach could cause higher number of dropped calls when user gets behind obstacle and hysteresis margin in leaving condition is too high.

### 3.3 Handover process

Increasing number of femtocells with much lower area of coverage than macrocell will in every case increase number of handovers. Therefore it would be very helpful, if we could lower duration of handover process. It will result in lower overhead in network, that is crucial for effective networks with high number of users. Especially with future M2M (Machine to Machine) communication. Faster handover will be valuable also for users with higher velocity because if handover would be faster, these users do not need to stay connected to macrocells all the time. As written before, because of using public internet as backhaul, it can take much longer for all messages between femtocells and operator's network to arrive than in his closed network.

One of the proposed solution called prefetch-based fast handover [13] takes care of higher layer data for UE, which are sent to source cell and then

forwarded to target cell and all of that have to go through public internet. Because of latency in public internet it results in longer time of handover procedures than it is necessary.

In proposed prefetch-based fast handover every serving cell identifies all neighbor cells and defines proximity region. Proximity region is important because serving gateway knows that handover will be to target cell from proximity region list. All cells in this list must be prepared for handover of every UE associated to all serving cells in proximity list. When handover occurs then these higher layer data are sent to all cells in proximity region list but only the target cell of handover sends them to UE. Other cells throw these data away after some time.

### 3.4 Handover in 5G networks

With development of 5G networks new approaches to handover are discussed. In connection with 5G networks term cognitive network is very widely used. Network autonomously adapting and changing according to what is most needed. For example this networks can differentiate users accordingly to their behavior in network. All these areas are nowadays only discussed [14], but in future will probably be very important.

A completely different handover approach compared to classic handover in 2G or 3G networks is suggested in [15]. Basic idea is to use D2D (Device to Device) communication between UEs because D2D communication may happen in an area covered by multiple femtocells. Greatest advantage over using standard S1 interface between FAPs, which is through public internet, is in much lower latency. Author propose that every femtocell should have at least one associated UE creating TAN (Temporary Area Network) for D2D communication between UEs. This TAN would be used for handover procedure.

When one UE (called first) will be leaving area of coverage of serving cell, this UE will send message using D2D communication to other UE (called second) which is in same TAN but is connected to another FAP. This message contains request to send handover establishment for first UE to target cell that is serving second UE. Instead of using public internet, handover request will be sent using D2D communication.

# Chapter 4

## Description of simulation

Aim of this chapter is to describe all characteristics of used simulation and explain all assumptions that are made. Firstly, a model of city in which is simulation done and deployment of FAPs is explained. Followed by behavior of users and used handover scenarios.

### 4.1 Model of city for simulation

Structure in figure 4.1 represents basic part of model. In black color are buildings and roads between them are white. Because simulation is focused on crossroads where network has to choose from multiple FAPs, all of the buildings are simplified to basic blocks. One type of building is simple square which occurs the most and next type is rectangle which is created by connecting three squares vertically or horizontally.

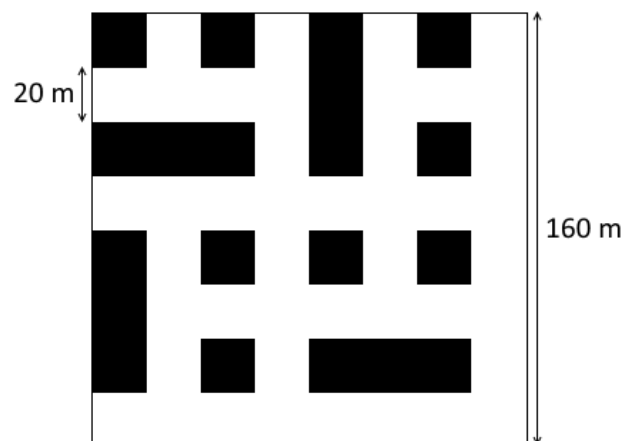

Figure 4.1: Basic structure of model.



Purpose of these rectangles is to limit regularity of model and to make it look more like real city. Each block represents square with dimensions 20 x 20 meters and this basic structure is composed of 64 squares. Thus 8 blocks on each side, that is in total 160 meters. This basic structure can be duplicated to create larger models.

For simulation I chose model of city composed of nine basic structures (three horizontally and vertically). All of them together create model of city with dimensions 480 x 480 meters. The model could be even bigger but with size of model number of users in city grows and it would dramatically increase demands for compute power. However it is not an issue because for this type of simulation it is not necessary. A complete model in which is simulation done is in figure 4.2.

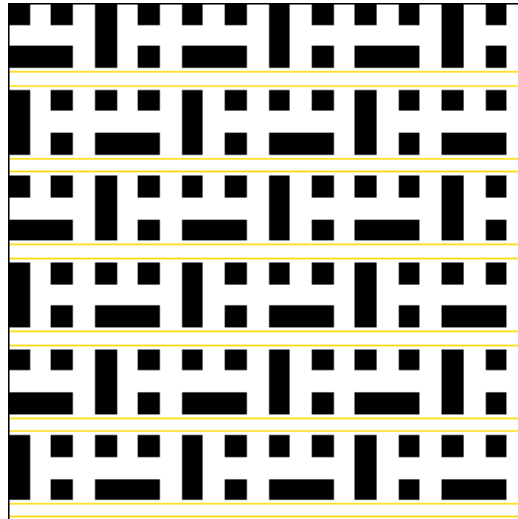

Figure 4.2: Complete model of city with main roads.

Real cities usually have narrow main roads with higher density of traffic therefore in next part main roads in model are created. Beside main roads there are back streets all over city that connect these main roads. All horizontal roads without any obstacle in them are main roads. Main roads are highlighted by two yellow lines in figure 4.2. Used model contains six of them in total, spread out regularly all over the city. All other roads are back streets. This model has only two types of roads because more types would create more complex model without significant impact on simulation results.

## 4.2 Placement of FAPs and their signal ranges

Many scenarios are possible for FAP placement. Whether place FAPs inside buildings or in the streets. And if it is chosen in the streets, then it is possible to place them at crossroads, between buildings or even in both places.

In my model FAPs are placed only between buildings and not at crossroads. This option is better for this simulation because crossroad is a place where directions of all users vary and there is usually need to change serving cell. And for femtocells is crucial to change serving cell correctly because of their low signal range that can cause dropped call when current serving cell is overshadowed. This situation usually occurs when user gets behind corner and signal level drops dramatically.

In simulation I compare number of dropped calls and handovers with FAPs density. Lower percentage means lower number of deployed FAPs. One hundred percent is maximal number with available FAP in between every building. For this exact size of city one hundred percent is 252 available FAPs. A model of city with all possible FAPs deployed is in figure 4.3. Every FAP is represented by blue circle.

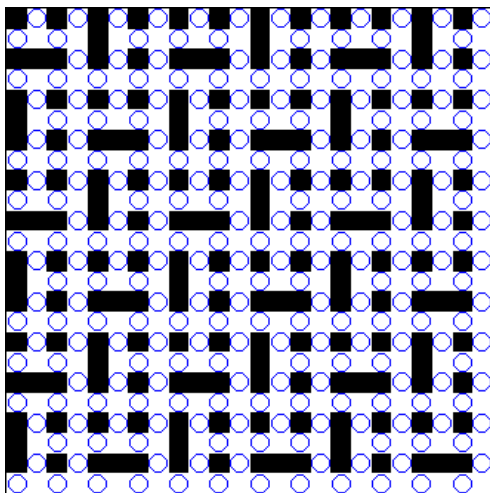

Figure 4.3: Model with 100 % of FAPs available.

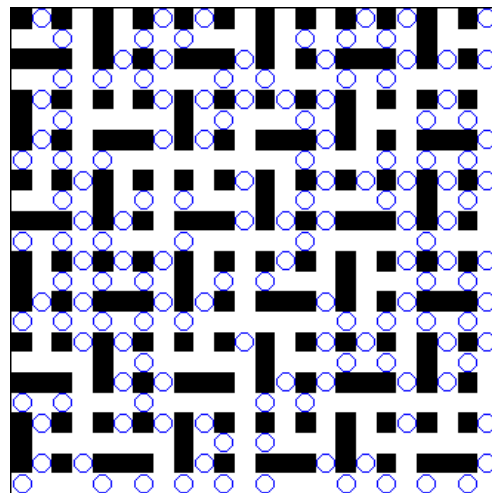

Figure 4.4: Model with 60 % of FAPs available.

Only difference between figure 4.3 and figure 4.4 is number of available FAPs in the city. In figure 4.4 is exactly 150 FAPs what is about 59.5 % of all. Condition for each deployment of FAPs is to differ from preset percentage value only by one percent at maximum. But the simulation does not run only in one exact deployment. Each final value is averaged from twenty

different deployments. Therefore average percentage is almost identical to preset value and small differences are insignificant because of the nature of simulation. But most importantly every scenario uses exactly the same deployments. This is really important because purpose of this simulation is to compare scenarios in between themselves.

The signal from each FAP spreads only in roads in line of sight and buildings create impenetrable obstacles. Strong signal is only in places where the FAP is, or in the next block on each side in line of sight. Coverage of strong signal is illustrated in figure 4.5 with blue lines with higher density.

Handover to FAP can occur only when user is in range of strong signal, thus only to FAPs which are next to him. In line of sight signal can spread even further, but is weaker. In simulation is this range up to two blocks next to FAP. This is illustrated in figure 4.5 with blue lines with lower density.

Thanks to this fact, users can stay connected to one FAP for longer time if they move in same direction and a suitable FAP is chosen. Therefore it is important to choose best possible FAP to connect to. This can reduce number of unnecessary handovers resulting in less signalization in network. Behind the corner signal does not spread therefore every time user gets behind the corner, connection with serving cell is lost and dropped call occurs.

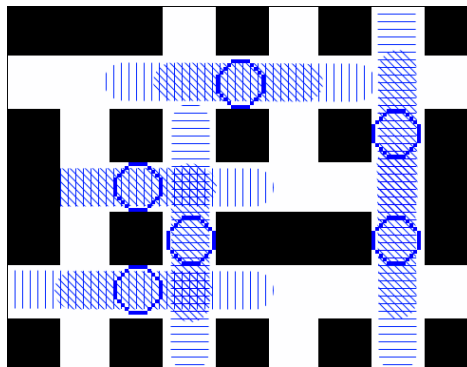

Figure 4.5: Signal ranges of FAPs.

If a FAP to which user could be connected instead is behind a corner, then this dropped call is caused only by wrong handover decision. Total number of these unnecessary dropped calls can be lowered by using handover scenarios that predict movement and choose FAPs in direction of predicted movement. However if these priorities are chosen wrongly, it can even increase number of unnecessary dropped calls. Therefore these priorities have to be chosen very wisely.

### 4.3 Mobility model

One of the crucial thing when creating movement of users is to make close approximation to reality. Basic assumption is that users can move only in roads and buildings are forbidden areas for them because buildings create obstacles. In this model all users have same velocity. Differentiation of velocity would add new challenges and make simulation more complicated. Therefore these attributes are neglected to enable focus on more essential features.

At the beginning of simulation certain defined number of users is randomly placed all over the city. There is no priority in placing them, therefore every place has the same probability. Figure 4.6 shows model of city during first step of simulation when defined number of users is randomly placed all over the city. In this particular case 40 users are generated and each one of them is represented by red dot. But number of red dots is lower than number of users because some of them are located in the same place. In simulation I chose 400 users in total and this number is in figure 4.6 lower only for better explanation.

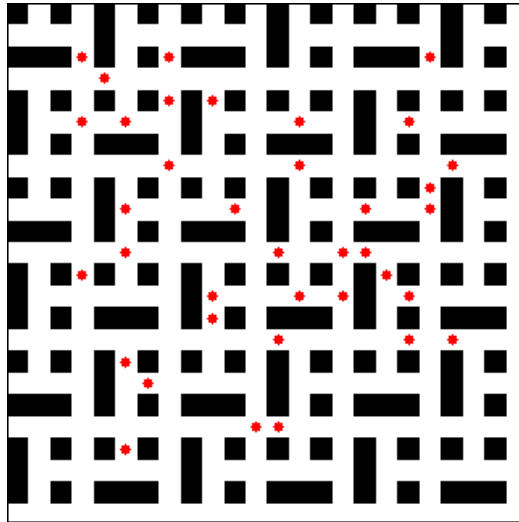

Figure 4.6: Generation of users.

In each step of simulation each user moves from one square to the next one and it is not possible to skip any square. Each direction is given a probability  $P$  based on priority from equation 4.1. At the beginning of each step for every user random number from range 0 to 1 is generated and this number determines where user will go.

Sum of probabilities  $P$  of all available directions is always one, as stated in equation 4.2. Direction with lowest index  $i$  has range from 0 to its  $P$ . Then continue ranges for other available directions at crossroad up to the sum of one. In next step direction with range where generated random number belongs is chosen.

$$P_i = \frac{\alpha_i - \beta m_i}{n + r(\alpha_x - 1) - \beta m_x} \quad (4.1)$$

$$\sum_i^n P_i = 1 \quad (4.2)$$

Where  $P_i$  is probability of movement in direction  $i$  and  $n$  is number of all available directions where user can go. Every direction is represented by index  $i$ . Variable  $r$  is number of directions with main roads where user can continue.

Parameter  $\alpha$  represents priority of the road, whether it is main road or back street. Value for back street is always one and main road has defined larger value. Behavior of users depends on this value. With larger value users use main roads more often.

Parameter  $\beta$  is used to lower probability of going straight in same direction. With larger value users more likely change direction of movement at crossroads instead of going in the same direction. With parameter  $\beta$  is connected variable  $m$  representing number of passed crossroads of the same user in one direction.

$\alpha_x$  and  $m_x$  are values of  $\alpha$  and  $m$  for current crossroad. Thus if there is main road,  $\alpha_x$  has same value as main road and  $m_x$  represents how much crossroads user passed in this road. How exactly equation describes movement and meaning of all variables and parameters will be explained more in next paragraphs.

To determinate for which direction is probability calculated, each direction is given index  $i$  with number of current direction. Directions are named clockwise from left, which has number one. When route in target direction is not available then this number is skipped. A few of the situations are illustrated in figure 4.7.

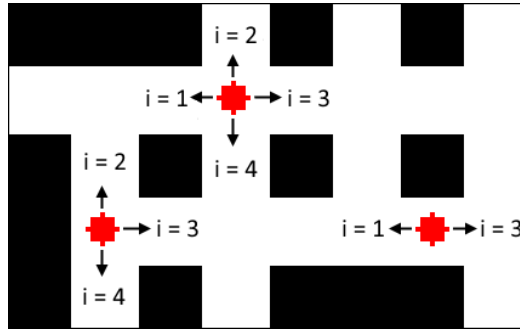

Figure 4.7: Naming of directions.

For example, when probability in first direction is  $P_1 = 0.4$ , in second is  $P_2 = 0.2$  and in third is  $P_3 = 0.4$ . Sum of all these probabilities is one. And when generated random number is for instance 0.5. User chooses second direction because for first direction number should be from 0 to 0.4 and for third direction from 0.6 to 1. But generated number is in range from 0.4 to 0.6, thus belongs to second direction.

After the start of the simulation users can go in all directions because there is no previous movement. Therefore all directions have even probability as illustrated in figure 4.8. But this situation occurs only in the first step of simulation after all users are generated.

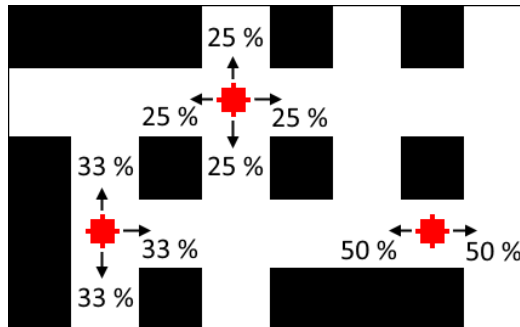

Figure 4.8: Probability in first step.

In next steps users start moving and new criteria are applied. It is forbidden to go back. Thus user cannot go back to the same place in the next step. It is possible to go there later but not in next step. When user is between buildings and not at crossroad, he can continue only in the same direction and cannot go back.

Next criterion for prioritization of movement increase probability to change direction when user is moving in one direction for longer time. With every next crossroad he pass in the same direction the probability for this direction is decreasing. It is illustrated in figure 4.9, where user is going from north to south without changing direction and at each crossroad his probability to go straight is lower. In this figure  $\beta = 0.1$ . Comparison of various values of  $\beta$  parameter is in next chapter.

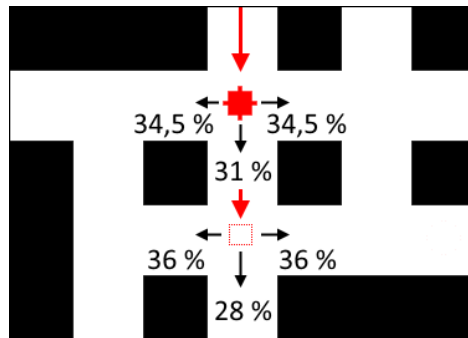

Figure 4.9: Probability to change direction criterion.

To all previous criteria one of the most important is added that reflects importance of main roads. Main roads have greater priorities because users usually want to get further away from place where they start and for this purpose they choose main roads. With increasing value of parameter  $\alpha$  grows usage of main roads. Probability for each direction when user is in main road is in figure 4.10. For this figure  $\alpha = 5$ , and main road is represented by yellow narrow lines. User is moving from right to left and in first step he can go in main road in both directions, which have same priority. Therefore probability for going left is in first step lower than in second.

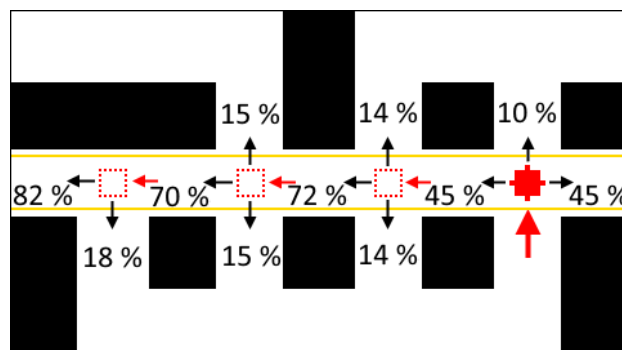

Figure 4.10: Probability in main road.

When user gets to the border and leaves the model, in the next step new user enters on side where previous left. But not in the same place, because position of new user is randomly generated along this particular side. Creating of new user when another disappears ensure same number of users during entire simulation. Therefore it is possible to set exact number of users in the model at one moment.

Actual probability for each direction can be slightly different than in previous figures because for purpose of explanation these values are rounded. Probabilities in figures are also represented by percentage ranges.

In parameters of simulation I can set number of users at one moment and total number of steps that determines length of simulation. There is also option to select various  $\alpha$  and  $\beta$  parameters.

During simulation movement is written into two matrices which are at the end written to text files. With this movement of users I can work later in simulation of different handover scenarios and because the movement is still the same it is possible to compare them afterwards.

Simulation of different handover scenarios also starts after first one hundred steps of movement, when distribution of all users is based on suggested algorithm for movement. And influence from random placement at the start of simulation is gone.



## 4.4 Handover scenarios

### 4.4.1 Scenario A

Scenario A is a classic handover scenario without any priority for FAPs. This scenario is used as reference for other scenarios to compare them. In this scenario every cell in proximity of user has same priority to be serving cell.

$$P_{Ai} = \frac{1}{n} \quad (4.3)$$

Where  $n$  is number of available FAPs to connect to and  $P_{Ai}$  is probability for target FAP in direction  $i$  to which user can be connected.

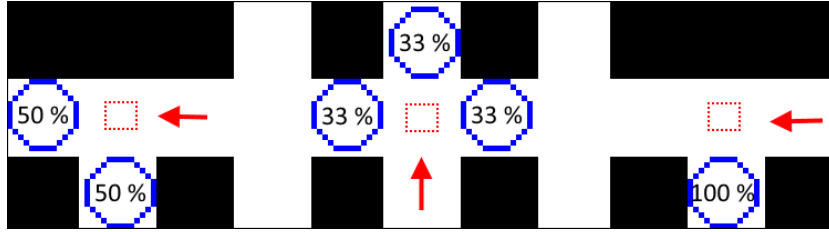

Figure 4.11: Probability in scenario A.

Equation 4.3 says that probability  $P$  is evenly divided between all available FAPs. Figure 4.11 also illustrates that decision about handover is only made at crossroads. Each FAP is represented by blue circle and users are represented by red squares. When two FAPs are available, each has 50 % chance to be serving cell and when there is only one FAP then user can connect only to this one.

### 4.4.2 Scenario B

On the other hand, scenario B uses criterion based on movement prediction of users and location of the FAP, whether it is on main road or not. Equation 4.4 for scenario B is the same as equation 4.1 for movement. But all variables and parameters are for FAPs instead of roads. Parameters  $\alpha$  and  $\beta$  can be also different than ones for movement. However, in simulation same parameters for movement and for FAPs are used.

$$P_{Bi} = \frac{\alpha_i - \beta m_i}{n + r(\alpha_x - 1) - \beta m_x} \quad (4.4)$$

Where  $P_{Bi}$  is probability in direction  $i$ ,  $n$  is number of available FAPs at crossroad and  $r$  is number of available FAPs in main road, which have greater priority. This priority is represented by parameter  $\alpha$ . Parameter  $\alpha$  for back street has always value one. Parameter  $\beta$  lowers probability to go straight in same direction for longer time and  $m$  is number of crossroads passed in one direction. Parameter  $\beta$  in combination with variable  $m$  lowers probability to go straight in direction  $i$ .  $\alpha_x$  and  $m_x$  are maximal used values of  $\alpha$  and  $m$  at current crossroad.

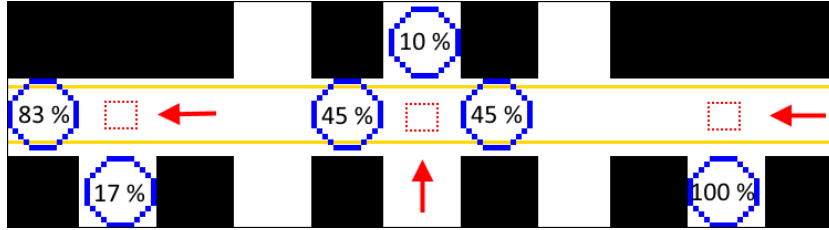

Figure 4.12: Probability in scenario B.

Figure 4.12 shows probability for handovers in main roads based on equation 4.4. Parameters are same as for movement, thus  $\alpha = 5$  and  $\beta = 0.1$ . Priority for connecting to FAPs in main roads are much greater then for FAPs in back street. Main road is in figure indicated by two yellow lines. When there is no main road then this scenario is the same as scenario A, thus in this case priorities are the same as in figure 4.11.

This scenario also lowers probability when user goes straight in same direction for longer time. However, there is no figure for this criterion because it is very similar to movement in figure 4.10. Only the priority is for FAPs instead of roads. Thus each available road in this figure should be replaced with FAP.

### 4.4.3 Scenario C

Scenario C is similar to scenario B but also adds priority based on occupancy of each FAP in past. In short, FAP that is most used by other users has greater priority than FAP which is not used that often. This priority is based on total number of users which were connected to this current FAP during defined time interval in past. Then this number is compared with other numbers for all available FAPs in proximity to which user can connect.

$$P_{Ci} = \frac{P_{Bi} + \gamma \frac{c_i}{\sum_i^n c_i}}{1 + \gamma} \quad (4.5)$$

Where  $\gamma$  is parameter for criterion of most used FAPs. Variable  $c_i$  represents total number of users which were connected to FAP in direction  $i$ . Number of available FAPs is  $n$  and  $P_{C_i}$  is probability from equation 4.4.

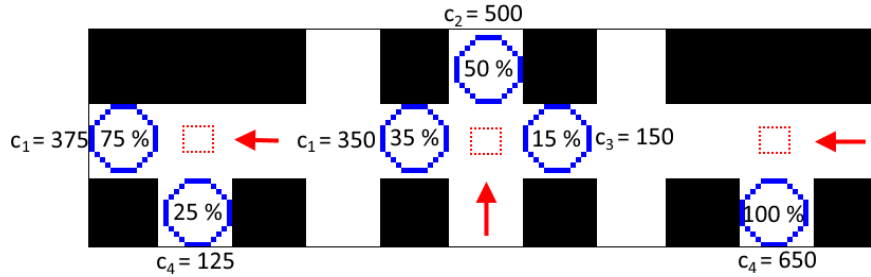

Figure 4.13: Probability in scenario C.

Figure 4.13 shows only probability based on criterion of most used FAPs because other criteria are explained in previous scenarios. Variable  $c_i$  represents total number of served users from the beginning of simulation for FAP in direction  $i$ . Probability of each FAP is number of served users of this FAP divided by sum of all served users of available FAPs in proximity of user. With increasing of  $\gamma$  parameter, grows importance of occupancy prediction criterion compared to movement prediction which can be with high values of  $\gamma$  in most cases neglected. On the other hand when  $\gamma = 0$ , then this scenario is same as scenario B.

$c_i$	$\sum_i^n c_i$	$\frac{c_i}{\sum_i^n c_i}$
375	500	0.75
125	500	0.25
350	1000	0.35
500	1000	0.50
150	1000	0.15
650	650	1

Table 4.1: Probability in figure 4.13.

Further explanation of each value in figure 4.13 is in table 4.1. This table in connection with figure 4.13 shows how priority in criterion of most used FAPs is calculated.

# Chapter 5

## Simulation results and discussion

In this chapter I compare simulation results in number of dropped calls and number of handovers. This chapter also contains explanation and comparison between various values of  $\alpha$ ,  $\beta$  and  $\gamma$  parameters used in simulation.

### 5.1 Parameters $\alpha$ and $\beta$

Different values of parameters  $\alpha$ ,  $\beta$  and  $\gamma$  can be set in my simulation, and differences between various values of these parameters are shown in this section.

Figure 5.1 shows ratio of number of users going in main roads to number of users in back streets for various  $\alpha$ , where  $k_r$  represents this ratio.

If  $\alpha = 1$ , thus main roads have same priority as back streets, ratio is lower than one. It is due to higher number of back streets than main roads. With increasing of alpha parameter this ratio rises almost linearly. In simulation I chose  $\alpha = 5$  because ratio  $k_r$  is very close to value one, thus main roads use same number of users as back streets. But number of main roads is lower than back streets therefore in main roads is density of users higher.

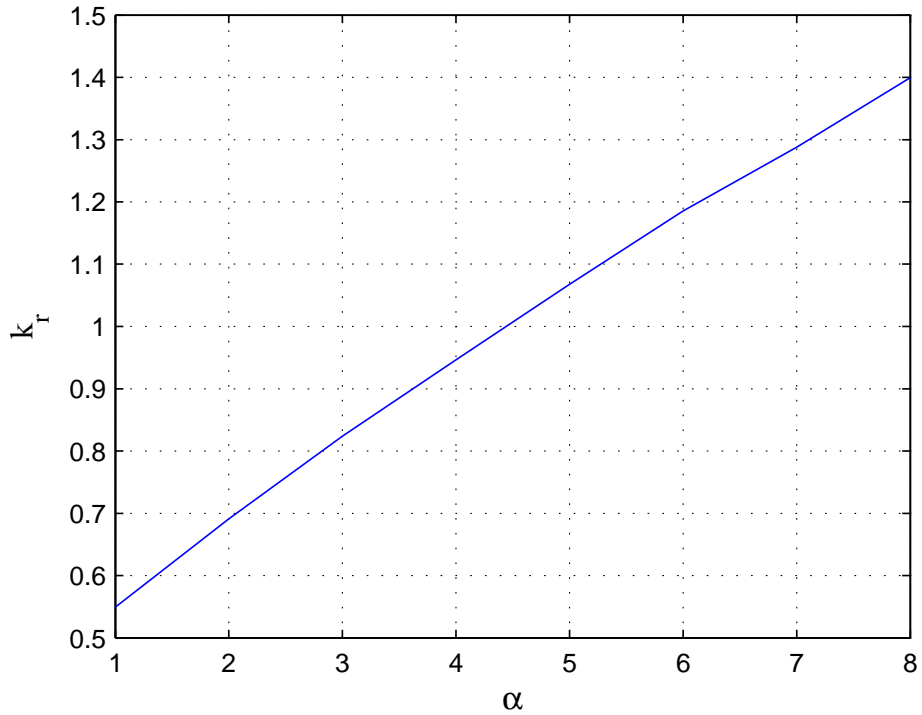

Figure 5.1: Ratio of movement ( $k_r$ ) in main roads ( $\alpha$ ) to back streets.

Figures 5.2,5.3,5.4 and 5.5 illustrate how probability with each passed crossroad decreases for various  $\beta$  parameters. Where  $P_d$  is probability that users will go straight in the same direction. This probability depends also on  $\alpha$  parameter, when greater values has lower decrease of the probability. All figures are for  $\alpha = 5$ , which is the same as in simulation.

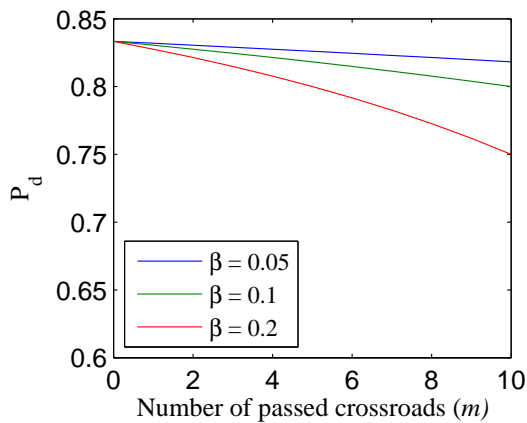

Figure 5.2: Main road for  $n = 2$ .

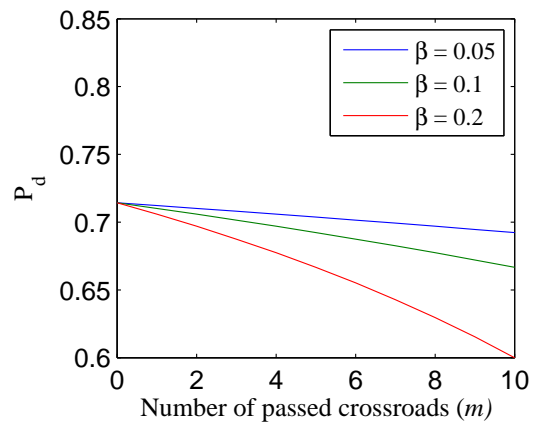

Figure 5.3: Main road for  $n = 3$ .

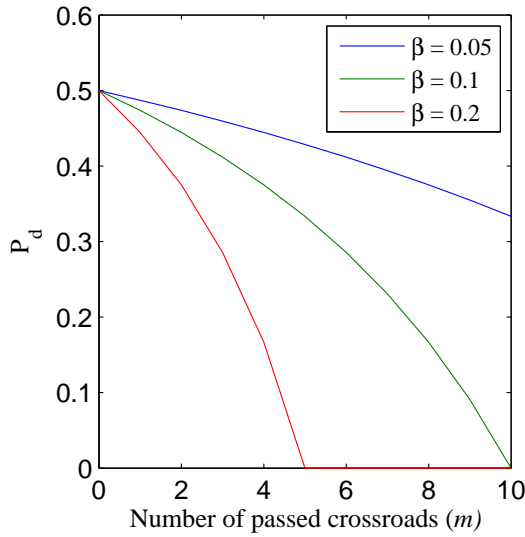

Figure 5.4: Back street for  $n = 2$ .

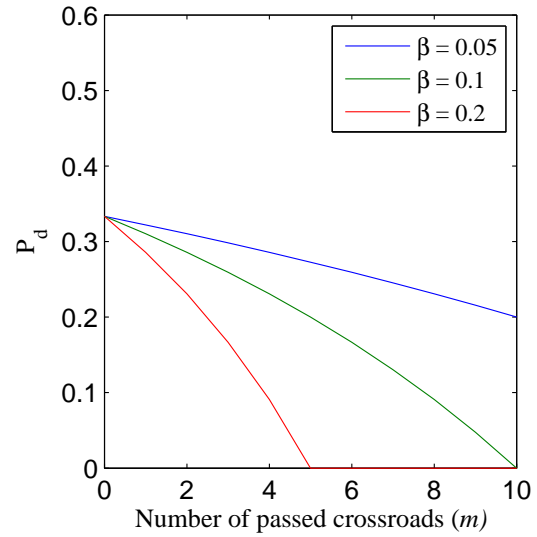

Figure 5.5: Back street for  $n = 3$ .

There are two figures for main roads which have higher priorities and another two for back streets. Hence each type of road has two figures and their only difference is in number of available roads at crossroad ( $n$ ), thus probability.

As can be seen in all figures,  $\beta$  values have an influence on decrease rate of probability. With higher  $\beta$  exact decrease of probability is for much lower number of passed crossroads. But this decrease cannot continue to infinity therefore when probability drops to zero, it stops decreasing and at the next crossroad if it is possible user will change direction.

Average number of passed crossroads and how this number depends on  $\alpha$  and  $\beta$  parameters is illustrated in figure 5.6.

Variable  $m_{avg}$  is average number of passed crossroads in one direction. Users change direction less often with lower  $\beta$  therefore in graph for smallest  $\beta$  is  $m_{avg}$  highest. With greater  $\alpha$  parameters this number is also higher because users stay in the same main roads for longer time. For  $\alpha = 5$  and  $\beta = 0.1$  used in simulation  $m_{avg} = 2.3$ . It means that every user in simulation goes straight in a row for 2.3 crossroads on average.

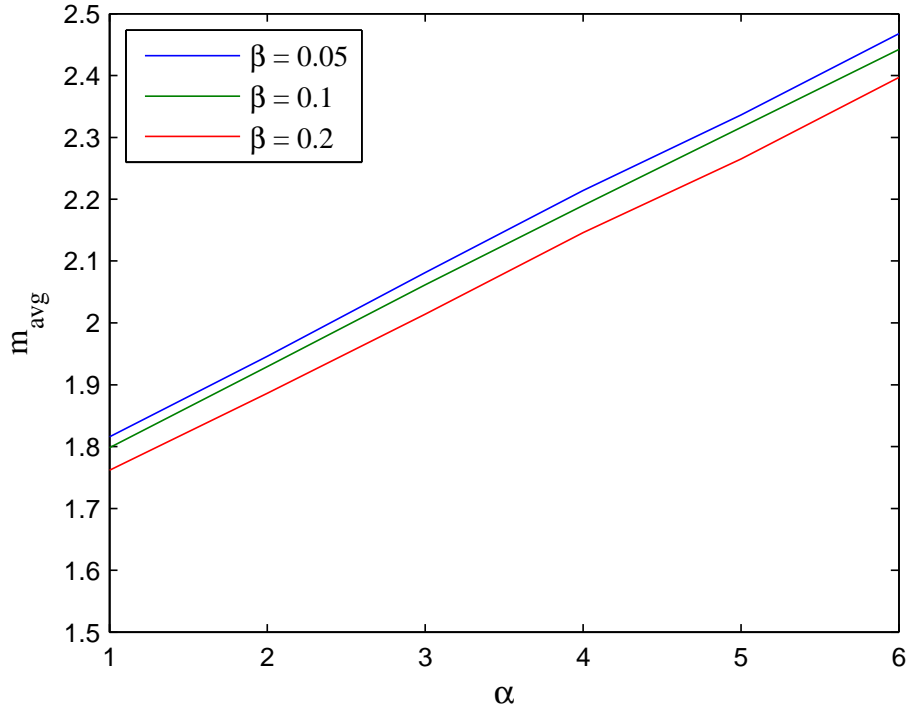

Figure 5.6: Average number of passed crossroads.

Parameter  $\beta$  for handover scenarios is the same as for movement, thus these comparisons with  $\beta$  applies for handover too. Also simulation uses same value of  $\beta$  for handover scenarios as for movement. These values only indicate how much probability for same direction drops therefore can be used same values.

## 5.2 Comparison of scenarios

Purpose of this simulation is to compare all three scenarios and prove that my proposed scenarios deliver better results. For this purpose I compared results in number of dropped calls and in number of handovers. Scenario A represents traditional handover scenario without any criterion therefore is used as reference for other two. Values of parameters are  $\alpha = 5$  and  $\beta = 0.1$ .

Results in all graphs are simulated for every ten percent of FAPs density and are not interleaved. Therefore few values have sharp transition between them. For example in figure 5.7 for density of 10 %. To align these sharp transitions much greater number of simulation would be required and it would take very long time to compute. But it is not needed because for higher values

of FAPs density these sharp transitions almost disappear.

### 5.2.1 Number of dropped calls

Average numbers of dropped calls for one step of user in simulation are in figure 5.7. With none of the FAPs deployed dropped call occurs in every step. With increasing number of deployed FAPs this number is rapidly decreasing. For 20 % of deployed FAPs dropped call is for every third step. With higher density of FAPs this number falls much slower and stops decreasing for about 80 % of available FAPs where dropped call occurs every fourth step on average.

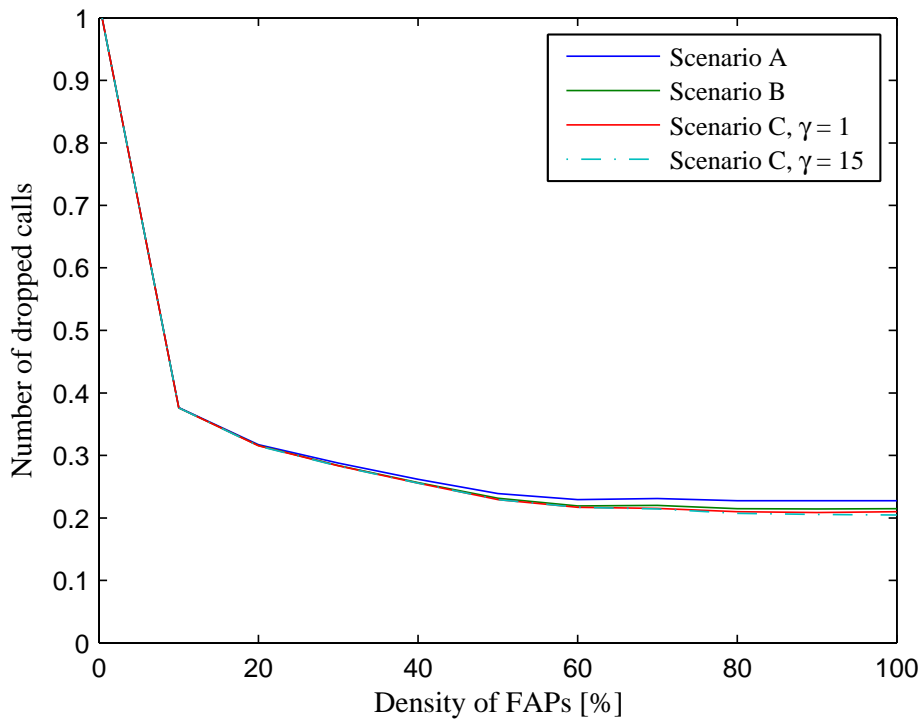

Figure 5.7: Average number of dropped calls.

With all deployed FAPs average number of dropped calls is slightly growing because there are more FAPs to which can be user connected and number of dropped calls caused by wrong handover decision is increasing. This situation occurs every time user is connected to FAP and gets behind corner where signal from this FAP cannot spread.



Figure 5.8 illustrates this fact and with more available FAPs the number of dropped calls due to wrong decision increases. However differences between all scenarios are also growing.

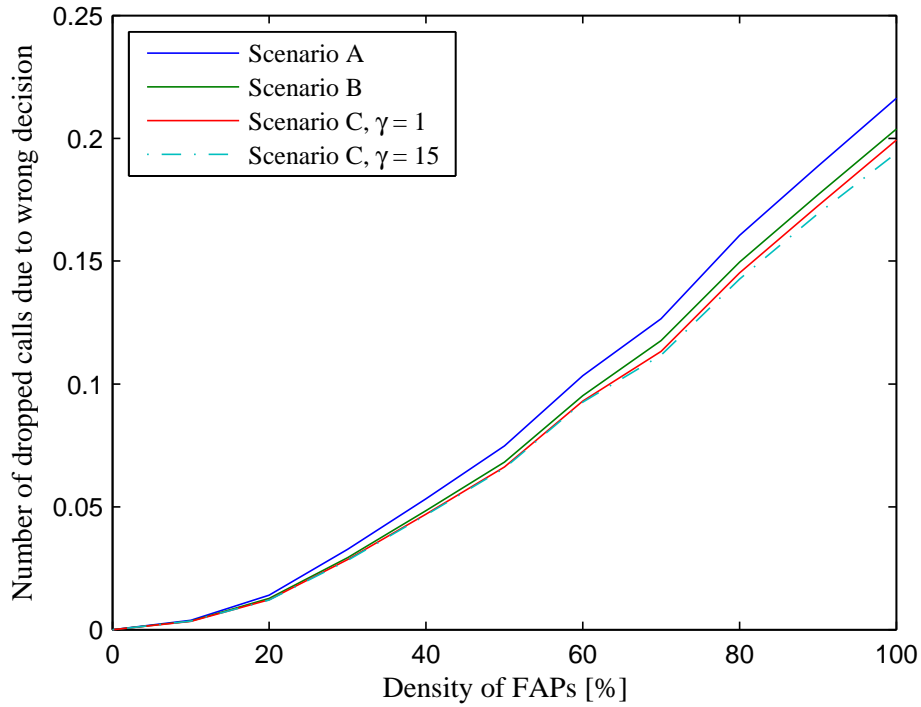

Figure 5.8: Average number of dropped calls due to wrong decision.

### 5.2.2 Number of handovers

Not only number of dropped calls but also number of handovers is important. Smaller number of handovers means less signalization thus smaller load in network. With low number of deployed FAPs number of handovers is also low, because there is no FAP to connect to as can be seen in figure 5.9. Where number of handovers is normalized for one user and one step of simulation.

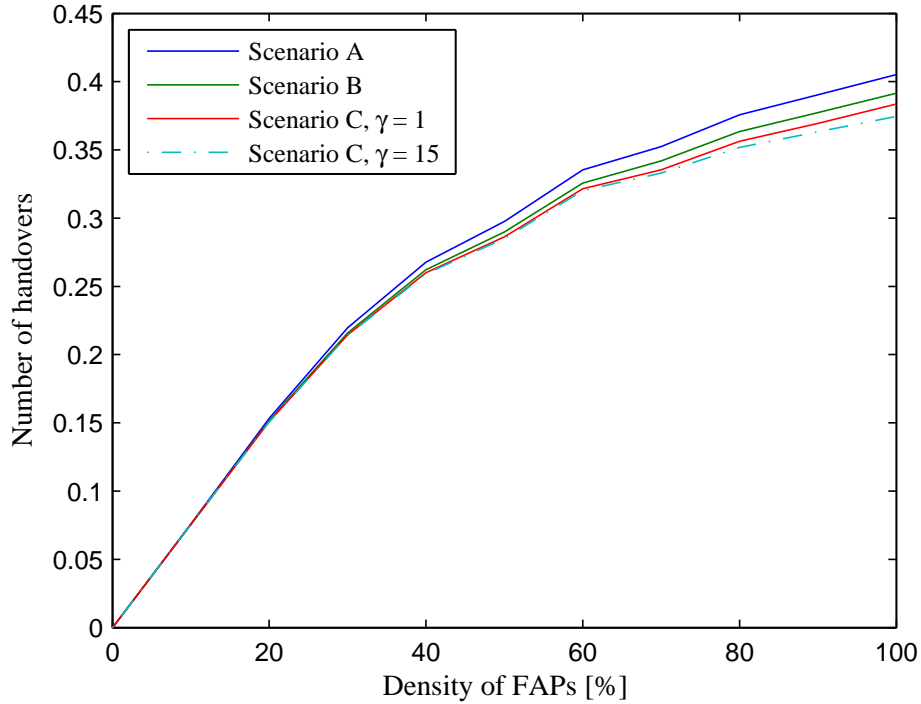

Figure 5.9: Average number of handovers.

To about thirty percent almost no difference is between all three scenarios because there is usually only one FAP to connect to and no other choice. But with increasing number of deployed FAPs differences are much greater. If no prediction would be applied, maximal number of handover should be 0.5 because crossroad is every second step.

But when correct FAP is chosen then user can stay connected to one FAP for longer time. Therefore maximal number of handovers is lower than 0.5 and both proposed scenarios with movement prediction have even lower values.

### 5.3 Parameter $\gamma$

Scenario C is simulated both for  $\gamma = 1$  and for  $\gamma = 15$ . Because scenario C is very similar to scenario B and only parameter  $\gamma$  defines differences between them. For  $\gamma = 0$  is scenario C even identical to scenario B as can be seen in equation 4.5.

Therefore it is possible to compare criteria used in these two scenarios by setting various values of parameter  $\gamma$ . Higher value of  $\gamma$  means higher weight

of criterion used in scenario C compared to movement prediction criterion in scenario B.

Figure 5.10 illustrates how average number of dropped calls changes according to parameter  $\gamma$ . For this comparison 100 % of available FAPs is selected because the differences between scenarios are greatest.

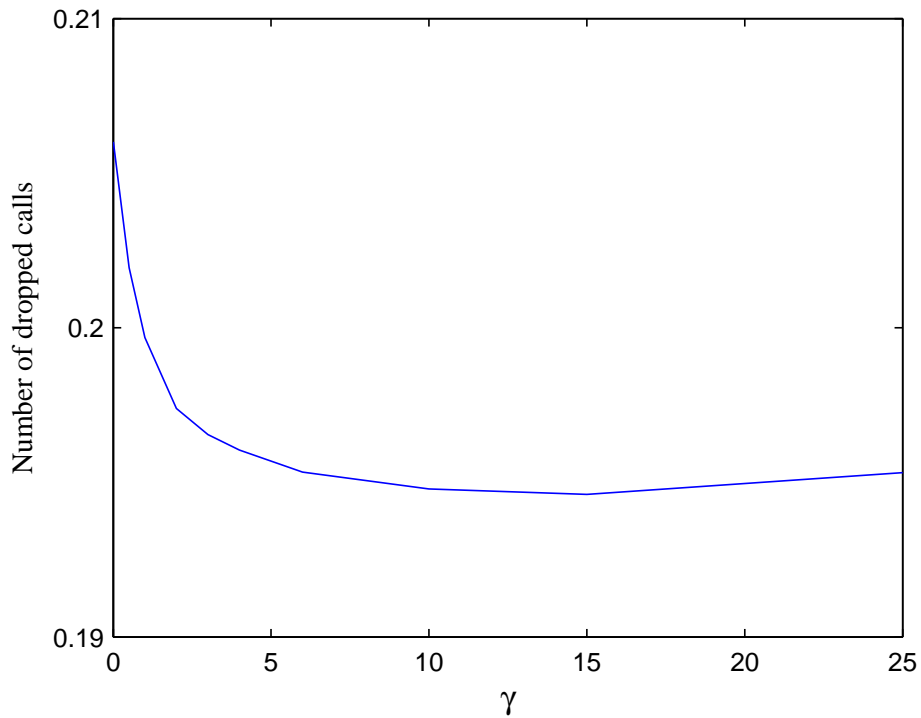

Figure 5.10: Average number of dropped calls for various  $\gamma$ .

With  $\gamma = 0$ , number of dropped calls is highest but with higher values of  $\gamma$  this number decreases significantly. Around value  $\gamma = 15$  is lowest and with higher values of  $\gamma$  where scenario B can be in most cases neglected, number of dropped calls slightly rise. Therefore scenario C is in simulation results both for  $\gamma = 1$  and  $\gamma = 15$ .

Proposed scenario C with  $\gamma = 15$  delivers best results for all values of FAPs density. Compared to scenario A, for 100 % of deployed FAPs scenario C is better by approximately 10 % in both number of handovers and dropped calls due to wrong decision. In Scenario B the improvement is smaller but still around 6 %.

# Chapter 6

## Conclusion

The goal of this thesis is to point out the issue of handover in femtocell network. Mainly because of small coverage area of femtocells handover occurs very often therefore it is important to lower this number by choosing the best possible target for handover. One solution how to achieve it is to set various additional conditions for handover. For this purpose I propose handover scenarios which adjust priorities of all femtocells and then I compare them in simulation.

Simulation is done in Matlab environment where I created a model of part of the city with users. Movement of users is based on suggested algorithm and it is possible to change behaviour of users with two parameters. First parameter defines how often main roads are used. Second parameter forces users to change direction more often. In the next step I use my model with movement of users for proposed handover scenarios.

In simulation three scenarios are used: A, B and C. Scenario A is without any modified priority and represents classic scenario. This scenario is used as reference to compare other two. Scenario B uses movement prediction and scenario C uses movement prediction with priority based on usage of femtocells in past.

Best results delivers scenario C which uses priority based on number of users served by each femtocell in proximity in past. Thus every femtocell compares number of served users with other femtocells in proximity and priorities are based on this number. In my simulation this scenario reduces number of dropped calls due to wrong handover decision by up to 10 %.

In this thesis I demonstrated that even very simple criteria can help avoid a few of unnecessary handovers. All information used in these criteria can be easily obtained from the network thus it should not be very difficult to use them. However the number of dropped calls is still high. Therefore only these criteria are not enough and a lot more of others are needed.

# Bibliography

- [1] SAUNDERS, Simon. *Femtocells: opportunities and challenges for business and technology*. Chichester, West Sussex, U.K.: Wiley, 2009, xxxvii, ISBN 9780470748169.
- [2] ZHANG, Jie a Guillaume de la ROCHE. *Femtocells: technologies and deployment*. Chichester: John Wiley, 2010, xxix, ISBN 9780470742983.
- [3] ORGANIZERS, ETRI a IEEE ComSoc SPONSORS. *The 12th International Conference on Advanced Communication Technology ICT for Green Growth and Sustainable Development*. Phoenix Park, Korea, Feb. 7-10, 2010, IEEE, p. 904-908, ISBN 9788955191462.
- [4] 3GPP TS 36.300: Evolved Universal Terrestrial Radio Access Network (E-UTRAN), Overall description. In: [online]. 18/3/2014 [cit. 2015-02-26]. [http://www.3gpp.org/ftp/specs/archive/36\\_series/36.300](http://www.3gpp.org/ftp/specs/archive/36_series/36.300)
- [5] 3GPP, Mobile Competence Centre. The Evolved Packet Core. In: [online]. [cit. 2015-04-30]. <http://www.3gpp.org/technologies/keywords-acronyms/100-the-evolved-packet-core>
- [6] YU, Jingjie, Mugen PENG a Yue LI. *A physical cell identity self-organization algorithm in LTE-advanced systems*. 7th International Conference on Communications and Networking in China, 2012, DOI: 10.1109/chinacom.2012.6417549.
- [7] 3GPP TR 23.830: Architecture aspects of Home NodeB and Home eNodeB. In: [online]. 10/2/2009 [cit. 2015-02-25]. [http://www.3gpp.org/ftp/specs/archive/23\\_series/23.830](http://www.3gpp.org/ftp/specs/archive/23_series/23.830)
- [8] Junren Chang, Yajuan Li, Shulan Feng, Haiguang Wang, Chengzhen Sun, Philipp Zhang, *A Fractional Soft Handover Scheme for 3GPP LTE-Advanced System*. IEEE International Conference, 2009.

- [9] HAN, Jihai a Bingyang WU. *Handover in the 3GPP long term evolution (LTE) systems*. 2010 Global Mobile Congress [online]. 2010 [cit. 2015-01-25]. DOI: 10.1109/gmc.2010.5634584.
- [10] SUNG, Nak Woon, Ngoc-Thai PHAM, Hyunsoo YOON, Sookjin LEE a Won Joo HWANG. *Base station association schemes to reduce unnecessary handovers using location awareness in femtocell networks*. *Wireless Networks*, 2012, vol. 19, issue 5, p. 741-753. DOI: 10.1007/s11276-012-0498-0.
- [11] SHBAT, Modar Safir a Vyacheslav TUZLUKOV. *Handover technique between femtocells in LTE network using collaborative approach*. 18th Asia-Pacific Conference on Communications (APCC), 2012, DOI: 10.1109/apcc.2012.6388102.
- [12] LIM, Jaechan a Daehyoung HONG. *Mobility and Handover Management for Heterogeneous Networks in LTE-Advanced*. *Wireless Personal Communications*, 2013, vol. 72, issue 4, p. 189-201, DOI: 10.1002/9781119970446.ch13.
- [13] RATH, Ayaskant a Shivendra PANWAR. *Fast handover in cellular networks with femtocells*. 2012 IEEE International Conference on Communications (ICC), 2012, DOI: 10.1109/icc.2012.6363687.
- [14] NETWORLD2020 ETP. *5G: Challenges, Research Priorities, and Recommendations*. September 2014
- [15] DAMPAGE, Udaya a Chandika B. WAVEGEDARA. *A low-latency and energy efficient forward handover scheme for LTE-femtocell networks*. IEEE 8th International Conference on Industrial and Information Systems, 2013, DOI: 10.1109/iciinfs.2013.6731954.