

Czech Technical University in Prague

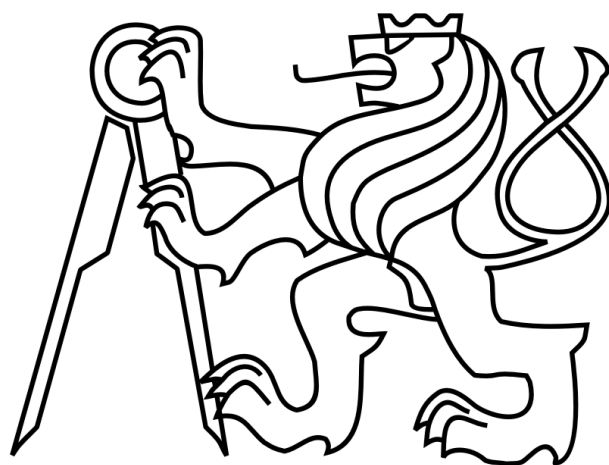

Doctoral Thesis Statement

Czech Technical University in Prague
Faculty of Electrical Engineering
Department of Radioelectronics

Jan Šafář

ANALYSIS, MODELLING AND
MITIGATION OF CROSS-RATE
INTERFERENCE IN ENHANCED LORAN

Ph.D. Programme: Electrical Engineering and Information Technology

Branch of study: Radioelectronics

Doctoral thesis statement for obtaining the academic title of "Doctor",
abbreviated to "Ph.D."

Prague, August 2014

The doctoral thesis was produced in a combined manner.

Ph.D. study at the department of Radioelectronics of the Faculty of Electrical Engineering of the CTU in Prague.

Candidate:

Ing. Jan Šafář
Research & Radionavigation Directorate
General Lighthouse Authorities of the UK & Ireland
Trinity House, The Quay, Harwich, CO123JW, UK

Supervisor:

Prof. Ing. František Vejražka, CSc.
Department of Radioelectronics
Faculty of Electrical Engineering of the CTU in Prague
Technická 2, 166 27, Prague 6

Supervisor-Specialist:

Doc. Dr. Ing. Pavel Kovář
Department of Radioelectronics
Faculty of Electrical Engineering of the CTU in Prague
Technická 2, 166 27, Prague 6

Examiners:

.....
.....
.....

The doctoral thesis statement was distributed on

The defence of the doctoral thesis will be held on
at a.m./p.m. before the Board for the Defence of the Doctoral Thesis in the branch of study Radioelectronics in the meeting room No. of the Faculty of Electrical Engineering of the CTU in Prague.

Those interested may get acquainted with the doctoral thesis concerned at the Dean Office of the Faculty of Electrical Engineering of the CTU in Prague, at the Department for Science and Research, Technická 2, Prague 6.

.....

Chairman of the Board for the Defence of the Doctoral Thesis
in the branch of study Radioelectronics
Faculty of Electrical Engineering of the CTU in Prague
Technická 2, 166 27 Prague 6.

CONTENTS

STATE OF THE ART	1
THESIS AIMS	4
METHODS	4
RESULTS	5
CONCLUSIONS	16
REFERENCES	17
AUTHOR'S PUBLICATIONS	19
SUMMARY	23

STATE OF THE ART

Over the past couple of decades, the U.S. Global Positioning System (GPS) has become an integral part of our society. Be it on land, at sea or in the air, GPS is an important and often the primary source of Position Navigation and Timing information. Although its qualities make it, in many aspects, superior over other PNT solutions, there are also some serious shortcomings and vulnerabilities common to all Global Navigation Satellite Systems (GNSS) – present, as well as future. These are largely a consequence of the extremely low GNSS signal strength levels at the surface of the Earth and have been documented many times before [1, 2, 3]. The associated safety, environmental and economic risks of relying on a single satellite navigation system have been assessed in a report [4], prepared for the U.S. Department of Transportation (the ‘Volpe report’). The report concludes that for critical applications, there will always be a need for a redundant system, providing back-up capabilities to GNSS. The solution, suggested by the Volpe report, is a Low Frequency (LF) terrestrial system nowadays called enhanced Loran (or eLoran for short).

So, what is eLoran? In the words of the International Loran Association’s eLoran Definition Document [5],

- eLoran is an internationally standardised PNT service for use by many modes of transport and in other applications. It is the latest in the longstanding and proven series of low-frequency, LOng-RANge Navigation systems.
- eLoran meets the accuracy, availability, integrity, and continuity performance requirements for aviation Non-Precision instrument Approaches (NPA), maritime Harbour Entrance and Approach (HEA) manoeuvres, land-mobile vehicle navigation, and location-based services, and is a precise source of time and frequency for applications such as telecommunications.
- eLoran is an independent, dissimilar, complement to GNSS. It allows GNSS users to retain the safety, security, and economic benefits of GNSS, even when their satellite services are disrupted.

In Europe, there are currently nine active Loran transmitters operated jointly by Denmark, France, Germany, Norway and the UK. European Loran service providers have created the European eLoran Forum to support the successful introduction, operation, and provision of eLoran services in Europe as part of a European Radionavigation Plan (ERNP). The General Lighthouse Authorities of the UK and Ireland (GLA), who lead the way in eLoran research and development in Europe, awarded a 15-year contract for the provision of an eLoran radionavigation service to improve the safety of mariners in the UK and Irish waters, and are currently preparing for the roll-out of eLoran Initial Operational Capability (IOC) in seven major ports in the UK [6].

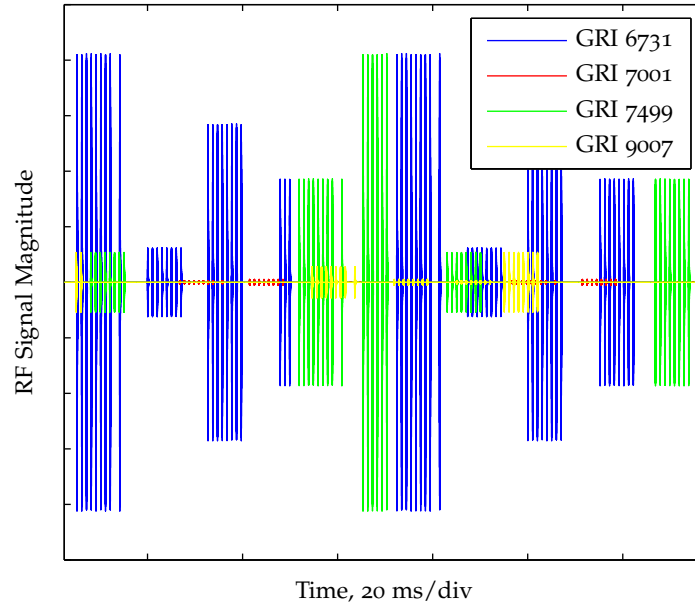

Figure 1: Cross-Rating Loran signals as would be received in Harwich, UK.

CROSS-RATE INTERFERENCE IN LORAN SYSTEMS

eLoran stations are organised in groups of typically 3 to 5 called *chains* or *rates*. The stations periodically broadcast short groups of radio pulses at a given Group Repetition Interval (GRI). In any given eLoran coverage area there are likely to be several chains of eLoran stations, each operating on a different GRI. As each eLoran station broadcasts at the same carrier frequency and uses practically the same waveforms, the signals of an eLoran chain are often disturbed by those of other chains (see Figure 1). This is referred to as Cross-Rate Interference (CRI) and, if left uncompensated, is a major source of measurement error in Loran systems. The issue was recognised relatively early in the development of Loran systems and this section provides a brief literature review on this topic.

As early as in the 1970's, proposals for high accuracy limited coverage by Loran-C type stations (for example harbour coverage) has brought out a need for discussion of the methods of minimising CRI between adjacent chains. Initial work focused on mitigating the effects of CRI by the judicious choice of phase codes and GRIs. Roland [7] investigated cross-correlation properties of Loran-C phase codes and proposed new codes accompanied by specific GRI values, which could be used in new Loran-C 'mini-chains' to suppress CRI through averaging.

Feldman [8] presented a frequency domain method for optimum GRI selection. Observing that pairs of GRIs will result in some spectral lines being close in frequency, he developed a method that searched for GRIs whose close spectral lines were near nulls present in the spectrum as a result of the phase codes. Feldman emphasised in his paper that both GRI selection and phase code structure are necessary considerations for the CRI minimisation and recommended changing the current Loran-C

phase codes for ones that produce deeper nulls in the spectrum and can therefore achieve a greater CRI suppression.

Gressang [9] presented a successful solution to a serious CRI problem encountered in the operation of a mini-chain within the service area of a standard Loran-C chain. A significant reduction in CRI was achieved in a field trial through the use of balanced phase codes¹ and a specially designed GRI. The results of the test validate the methods described by Roland and Feldman [7, 8]. Serious problems caused by unmitigated CRI were also reported by Engelbrecht and Schick [10, 11].

Van Etten [12] suggested an approach whereby CRI is suppressed through the use of a unique family of GRIs and the standard phase codes together with a different strobe phase code pattern in the receiver, leaving out some of the pulses to achieve a balanced pattern.

Frank [13, 14] presented a review of previous work on so called polyphase complementary codes, described generating methods for polyphase sequences and their relation to the theory of Loran phase coding.

More recently, possible changes to the Loran phase codes were also investigated by Swaszek [15]. Swaszek suggested codes with better CRI rejection properties when compared to the standard Loran codes (at the cost of sacrificing some of the sky wave rejection capability) and he also examined the possibility of constructing sets of mutually orthogonal phase codes so as to be able to implement a CDMA system.

In the 1990's when the European Loran-C chains were planned, a time-domain CRI analysis method was developed by a team at the Technical University Delft [16] to support the GRI selection process for the new chains. The method consists of a set of mathematical rules that allow the identification of potentially harmful combinations of GRIs but it does not allow quantification of the CRI-induced errors. The method was later extended [17] to also include the evaluation of data loss in Eurofix² data communication.

Despite CRI being possibly the strongest source of interference to Loran, very little work has been done on modelling its effects on the system's performance - presumably due to the complex nature of the interference. A semi-analytical time-domain approach to evaluating the effects of CRI on the acquisition and track modes of a Loran-C receiver was presented by Zeltser and El-Arini [18]. The method can be used to plot the carrier phase tracking error versus time and the predictions of the method were validated by comparison against the performance of several commercially available Loran-C receivers. However, the method is computationally intensive and would not be suitable for use in coverage prediction or GRI selection.

Modern eLoran receivers can mitigate the effects of CRI through the use of signal processing techniques such as 'CRI blanking' and 'CRI cancelling'. Some information about these algorithms can be found in references [19, 20, 21, 22]. However, no analytical performance models are available for these techniques.

Johnson et al. [23] investigated the potential performance improvements to be gained by single-rating all stations in the U.S. Loran system, re-configuring the chains and assuming also that CRI is mitigated by blanking. Although it does not give any analytical expressions for the

¹ I.e. phase codes with an equal number of positive and negative code values.

² Eurofix is an implementation of the Loran data channel used in Europe.

residual error due to CRI, this paper provides a useful starting point for this research.

THESIS AIMS

As can be seen from the literature review in the previous section, the issue of CRI has gained a great deal of attention in the past. The problem may become particularly relevant in Europe, as the GLA look to extend eLoran across their entire service area as part of the system's Final Operational Capability (FOC). Previous research provides some guidelines on how to minimise CRI within Loran-C chains, however these now need to be reviewed and updated to eLoran standards. Further, in spite of the attention that CRI has received, no comprehensive analytical models of the effects on Loran (or eLoran) performance have been published. On the topic of CRI, Pelgrum states in his PhD thesis [22]:

‘It is difficult to give an exact mathematical analysis on the effect of cross rate on receiver performance, because it is a function of many propagation and timing variables.’

A similar statement regarding CRI was made by Beckman who studied the effects of Continuous Wave Interference (CWI) on Loran-C [24]. This work aimed to provide such an analysis. More specifically, the aim of this research was to analyse the following:

1. What is the effect on accuracy performance within a coverage region when a new eLoran station is installed, given the increase in Cross-Rate Interference and a modern eLoran receiver's ability to cope with such interference through blanking or cancelling of interfering pulses?
2. What is the best method for selecting a Group Repetition Interval for a new station installation given modern eLoran technology, including receiver signal processing techniques?

METHODS

The results presented in the thesis were obtained mainly through analytical modelling. In deriving analytical models, use was made of the theory of signals and systems, random processes, estimation theory and number theory.

The analytical models developed in this work were verified by computer simulations using a set of Simulink[®] and MATLAB[®] tools created by the candidate. The models were further validated against the results of receiver test bench and field experiments involving commercially available eLoran equipment.

The analytical approach yields closed-form results and provides a valuable insight into the nature of CRI in Loran systems. However, in order to obtain mathematically tractable models, a number of assump-

tions had to be made. These assumptions are summarised at the end of each thesis chapter.

RESULTS

This section highlights the most important results of this research. The full list of contributions made by the candidate can be found in Chapter 1 of the the thesis.

RECEIVER SIGNAL PROCESSING MODEL FOR ELORAN

In order to enable the assesment of the effects of CRI on the accuracy performance of eLoran, the candidate developed a signal processing model for an eLoran receiver implementing state-of-the-art CRI mitigation algorithms. Due to a lack of published information on eLoran receivers, receiver design was considered as an estimation theory problem, and an optimal receiver structure was proposed based on the principles of Maximum Likelihood estimation. Various aspects of eLoran signal processing were taken into account including input bandpass filtering, channel sharing, sky wave interference rejection and carrier phase estimation. The resulting model is shown schematically in Figure 2.

The model allows the statistics of the carrier phase estimation error due to radio noise and interference to be determined, either by mathematical analysis or computer simulations, and is one of the key building blocks of the thesis. The thesis also shows how the carrier phase error translates into a pseudorange and positioning error.

PSEUDORANGE ERROR MODELS

Using the receiver signal processing model described above, the candidate derived analytical models of the pseudorange measurement error due to the following factors: Additive White Gaussian Noise (AWGN); uncompensated CRI from single or multiple interferers including the effects of sky wave borne CRI; signal loss due to CRI blanking; and residual error after CRI cancelling. The key results from these investigations are summarised below.

Uncompensated CRI

The model of uncompensated CRI assumes that no CRI mitigation algorithms are used at the receiver to suppress the cross-rating signal, except from the inherent pulse averaging performed in the main comb filter and phase-decoding filter (refer to Figure 2). The main contribution of this model is that it gives insight into the intricate structure of CRI and the way how different signal parameters affect the measurement error. Note also that in practice it is not always viable to apply CRI mitigation algorithms to all cross-rating signals in view. A certain portion of the signals is likely to be left uncompensated, and the models described in this section can then be used to quantify the impact on the measurement error.

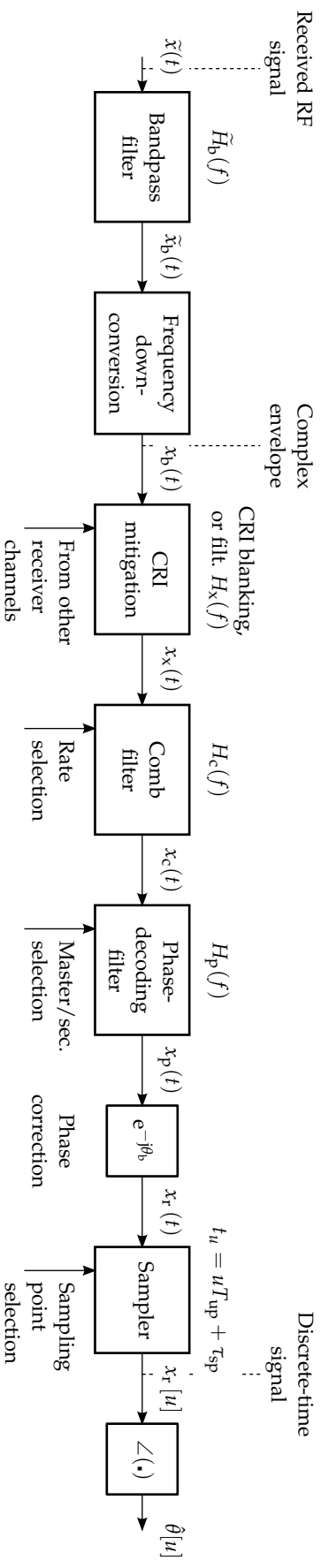
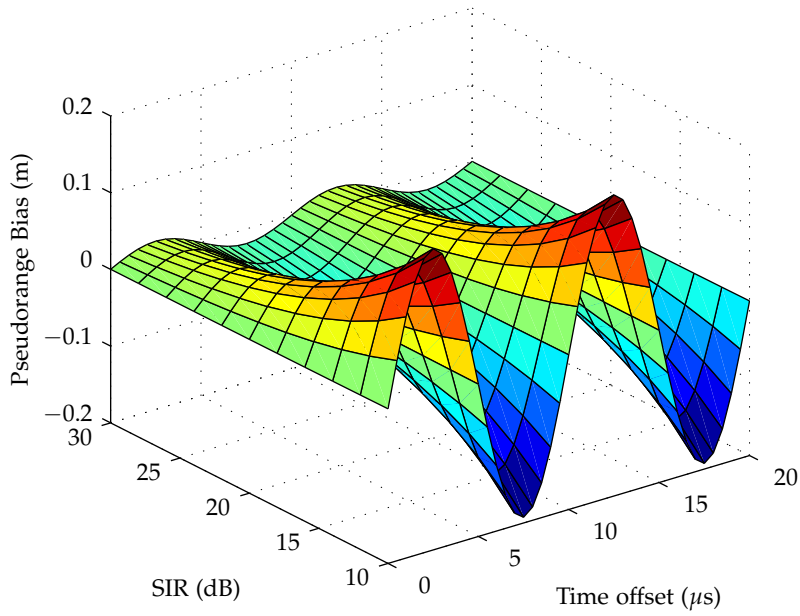
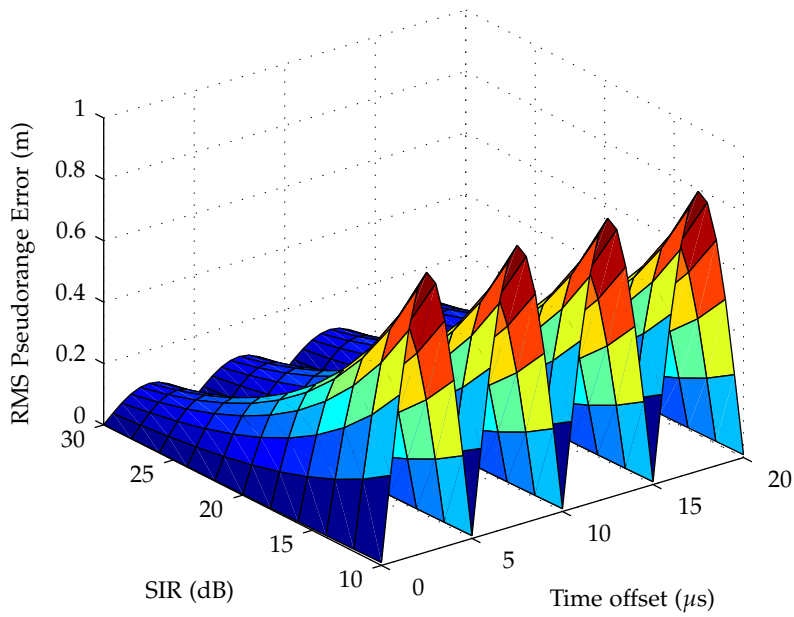

Figure 2: Signal processing model for a single channel of an eLoran receiver.



(a) Bias (max: 0.2 m)



(b) RMS error (max: 1.0 m)

Figure 3: Pseudorange measurement error due to uncompensated CRI as a function of SIR and signal time offset predicted by the DFD model; desired station: GRI 6731, secondary; interfering station: GRI 7499, master.

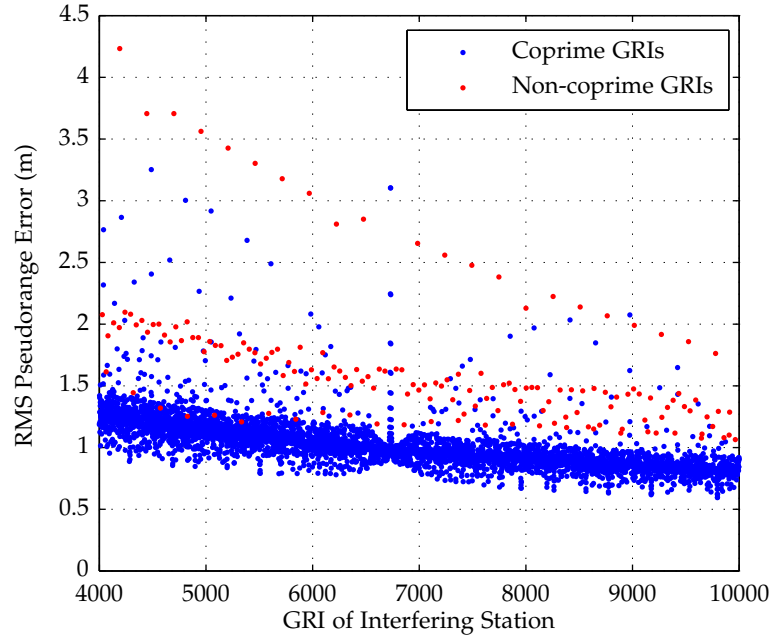

Figure 4: Pseudorange measurement error due to uncompensated CRI as a function of the interfering signal GRI as predicted by the DFD model; desired station: GRI 6731, secondary; interfering station: GRI as per horizontal axis, secondary; $\Delta\tau_2 = 2.5 \mu\text{s}$; SIR = 10 dB.

Early attempts at modelling CRI in the time domain led to considerable mathematical complications caused mainly by the pulsed, periodic nature of the signals. The problem was therefore approached in the frequency domain.

Two versions of the model were developed. The first version treats the signal parameters as deterministic constants, and the model is therefore referred to as the Deterministic Frequency Domain (DFD) model of CRI. The DFD model provides valuable insights into the peculiar nature of uncompensated CRI.

In the second version of the model, the signal time (and carrier phase) offset is treated as a random variable, and the measurement error is calculated as the average error over the range of all possible time offsets. The resulting model is therefore referred to as the Stochastic Frequency Domain (SFD) model of uncompensated CRI. The SFD model provides a macroscopic view of CRI and is mainly suitable for use in eLoran coverage prediction.

For illustration, Figure 3 shows the pseudorange measurement error due to uncompensated CRI between GRI 6731 and GRI 7499³ as a function of the Signal-to-Interference Ratio (SIR) and signal time offset as predicted by the DFD model. As can be seen from the figure, the error is highly sensitive to the time alignment between the cross-rating pulse trains (and therefore the position within the coverage area). The fast, sinusoidal, variations are caused by the changing carrier phase relationship between the signals.

³ GRI 6731 contains the Lessay, Soustons, Anthorn and Sylt stations and is considered here as the useful rate; GRI 7499 contains the Sylt, Lessay and Værlandet stations and is considered here as the interfering rate.

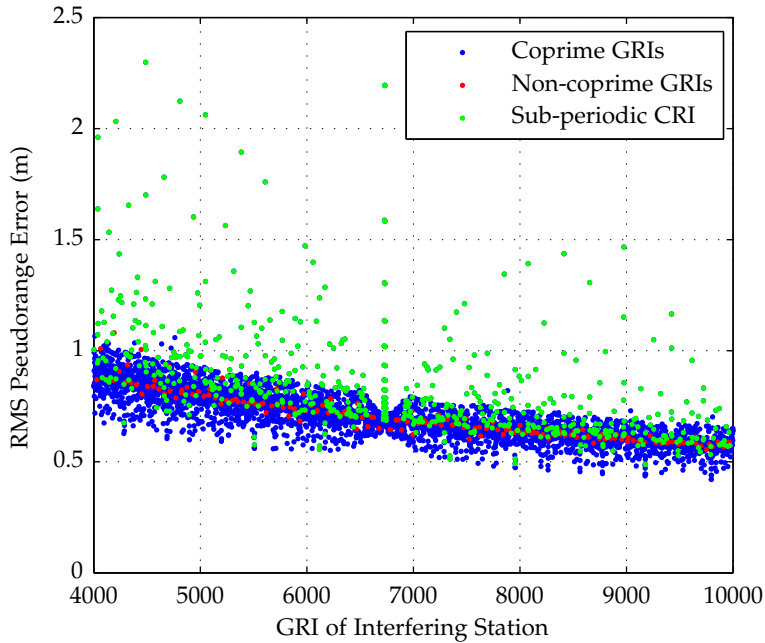

Figure 5: Pseudorange measurement error due to uncompensated CRI as a function of the interfering signal GRI as predicted by the SFD model; desired signal: GRI 6731, secondary; interfering signal: GRI as per horizontal axis, secondary; SIR = 10 dB.

Figure 4 then shows that the CRI-induced error is a complicated function of the cross-rating GRIs. There is a general decreasing trend in the magnitude of the error with increasing GRI of the interfering station. This is in line with expectations, as there are less interfering pulses per unit time. However, there are a large number of outliers that result in errors considerably above the main trend line. As also indicated in the figure, these outliers are mostly GRIs that are *not coprime*⁴ with the desired station's GRI.

Apart from non-coprime GRIs, there are also other combinations of GRIs that cause excessive measurement error. This is shown in Figure 5 which gives the pseudorange measurement error as predicted by the SFD model. Figure 5 bears a strong resemblance to Figure 4. As expected, the error shows a decreasing trend with increasing GRI of the interfering signal. The only substantive difference is that all non-coprime GRIs (shown in red) now appear close to the trend line. This is an expected result of the averaging applied in the SFD model. However, it can also be seen from Figure 5 that there are a considerable number of coprime GRIs that can give rise to high measurement error. On closer examination, it can be seen that the error peaks occur when the ratio of the GRIs in question is close to a simple fraction, such as $1/2$, $2/3$, $3/4$, etc. This is termed *sub-periodic CRI* and must be eliminated during the system design phase through the judicious choice of GRIs, together with any non-coprime GRI combinations.

The candidate established a relation between sub-periodic CRI and a mathematical construct called *Farey sequences* and designed a mathematically rigorous procedure for identifying pairs of GRIs that give

⁴ Two GRIs are said to be *coprime*, or *mutually prime*, when the Greatest Common Divisor (GCD) of the GRI identifiers is equal to 1.

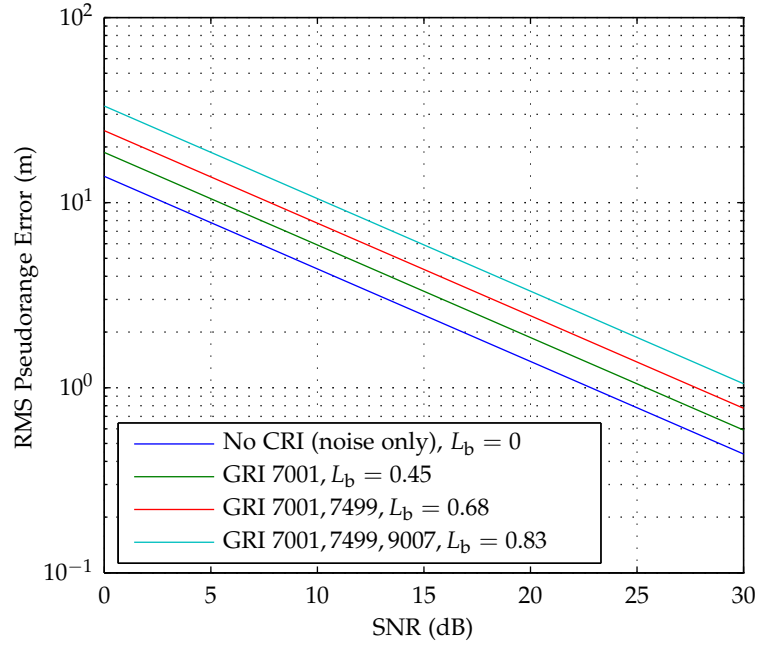

Figure 6: Residual pseudorange error after CRI blanking for a GRI 6731 signal interfered with other European GRIs.

rise to this kind of interference. This procedure was then used as part of a new GRI selection method for eLoran.

CRI Blanking

CRI blanking is a simple yet effective way of mitigating CRI. It works by eliminating from the received data all eLoran pulses that are overlapped by signals from other GRIs. In this way it is possible to completely suppress the interference; however, the price paid is a loss of useful signal energy which in turn leads to poorer performance with respect to noise.

Figure 6 illustrates the predicted effect of CRI blanking on the pseudorange measurement error in the presence of AWGN. The figure plots the pseudorange error for a GRI 6731 signal, assuming that up to three cross-rating GRIs are blanked. The eLoran signals in this example were assigned GRI values used in the North-West European system.

It can be seen from Figure 6 that when all the cross-rating signals are blanked, the blanking loss reaches 83% and the pseudorange error is approximately 2.4 times higher than if there was no CRI. Whether it is advantageous for the receiver to use blanking (and suffer some blanking loss) or not (and suffer some error due to uncompensated CRI) depends on the SIR and Signal-to-Noise Ratio (SNR), as discussed in detail in the thesis.

CRI Cancelling

CRI cancelling is a technique that may provide a viable alternative in situations where CRI blanking leads to an excessive loss of signal energy. With CRI cancelling, the receiver reconstructs a replica waveform of

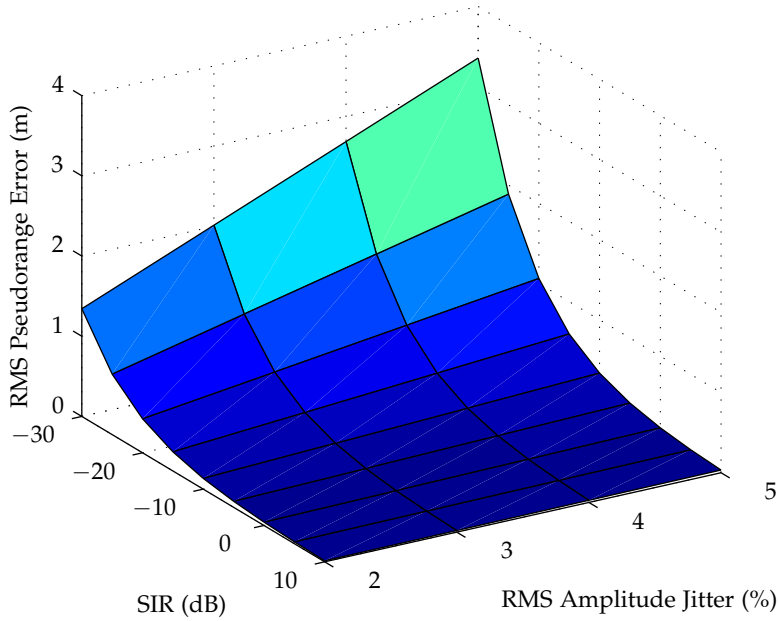

Figure 7: Residual pseudorange measurement error after CRI cancelling as a function of the SIR and standard deviation of the pulse-to-pulse amplitude jitter; desired signal: GRI 6731, secondary; interfering signal: 7499, master.

the interference and subtracts it from the composite received signal, effectively cancelling the interference while leaving the useful signal (largely) intact.

In practice, however, the cancelling is never perfect as the received eLoran waveforms are subject to various pulse-to-pulse disturbances which cannot be accurately estimated at the receiver. In this work, the candidate analysed the effects of pulse-to-pulse amplitude jitter on the effectiveness of CRI cancelling.

Figure 7 shows the residual measurement error after CRI cancelling as a function of the SIR and standard deviation of the pulse-to-pulse amplitude jitter, σ_A . As expected, the residual error increases with decreasing SIR and increasing amount of jitter. The effect becomes noticeable at approximately 0 dB SIR; weaker interference is effectively cancelled. It can, therefore, be concluded that the favoured strategy for CRI mitigation is the blanking of stronger interferers and cancelling of the weaker ones. Cross-rating signals that are at least 20 dB weaker than the useful signal can safely be ignored.

As part of the analysis of CRI cancelling, the candidate also derived an analytical expression for the Power Spectral Density (PSD) of an amplitude-jittered eLoran signal.

DESIGN AND IMPLEMENTATION OF A RECEIVER TEST BENCH

One of the difficulties encountered in this work was a lack of available information about eLoran receivers. Receiver manufacturers have not widely published the details of their eLoran receivers, and eLoran receiver performance standards, which could provide a valuable guideline for these investigations, have not been completed at the time

of writing. In order to get a better understanding of the performance of commercially available receivers, the candidate designed and implemented an eLoran receiver test bench, which allows the receiver performance to be studied under controlled radio conditions.

The test bench consists of an eLoran signal simulator, a Rubidium oscillator which acts as a highly stable source of clock signal for the simulator, a receiver coupler and a control\monitoring PC. The simulator allows the generation of synthetic eLoran signals with user-defined parameters but can also be used for replaying of actual LF signals captured in the field.

The simulator software consists of two applications - a signal design tool written in MATLAB[®], and a C++ programme that drives the digital-to-analogue conversion process. The signal generation process in the developed simulator is fully software defined and decoupled from the time-critical digital-to-analogue conversion tasks. There are, therefore, no limits as to the complexity of the waveforms that can be generated. For example, it is possible to simulate an arbitrary number of eLoran signals. This makes the simulator an excellent tool for studying the effects of CRI.

During this research, the candidate used the simulator to conduct tests with a state-of-the-art commercially available eLoran receiver and validate the analytical performance models derived in this thesis. This work was also presented to the Radio Technical Commission for Maritime Services (RTCM) Special Committee 127 on eLoran systems and there are plans to use the simulator in the development of the Minimum Performance Standards (MPS) for marine eLoran receivers.

CALIBRATED RECEIVER PERFORMANCE MODEL

The analytical receiver performance models developed in this work were refined and calibrated based on results of receiver test bench experiments to ensure that they accurately describe the performance of a state-of-the-art eLoran receiver. A field experiment was also conducted to confirm the validity of the results obtained by the laboratory testing.

For illustration, Figure 8 compares the pseudorange error for the stations in view observed during the field experiment with pseudorange error measured during laboratory testing (the laboratory test replicated the radio conditions observed during the field trial) and the error predicted using the calibrated receiver performance model; a comparison was also made with a model presented earlier by Lo et. al in reference [25].

It can be seen from Figure 8 that the analytical predictions of the revised pseudorange error model and the test bench results match closely the results of the field measurements. The field experiment, therefore, validates both the test bench methodology and the pseudorange error model developed in this thesis.

It can also be seen from the figure that residual CRI is a significant contributor to the measurement error in eLoran, particularly for weak signals (compare the 'noise and CRI' and 'noise only' models). It is also clear from the comparison that residual CRI has not been adequately modelled in existing coverage and performance models (see the 'Lo et al.' model).

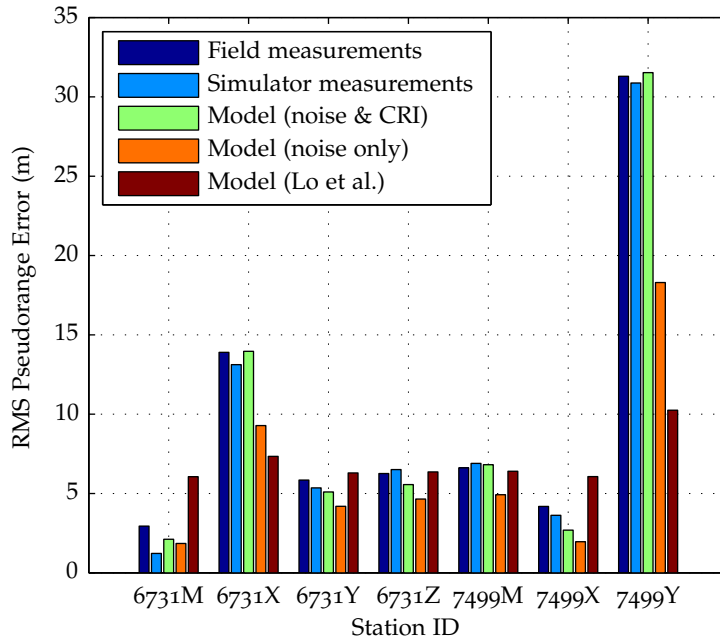

Figure 8: Pseudorange error: comparison of field measurement data with test bench and theoretical results and an earlier model presented by Lo et al. [25].

COVERAGE AND PERFORMANCE MODEL

The candidate integrated the calibrated receiver performance model into an eLoran coverage prediction tool originally developed by the GLA. The candidate also reviewed the atmospheric noise and sky wave propagation models used in the GLA coverage prediction tool and modified the models so that the effects of daytime vs. night-time radio conditions, and the probability distribution and non-stationary nature of atmospheric noise are appropriately taken into account. The updated coverage prediction model accurately represents the effects of CRI and therefore provides a tool to answer the first research question.

Sample plots produced by the coverage prediction tool are shown in Figure 9 to Figure 11. To the best of the author’s knowledge this is the first time such plots could be created.

In order to illustrate the importance of receiver CRI mitigation, Figure 9 shows predicted positioning accuracy assuming that no CRI mitigation algorithms are used. This plot should be compared to Figure 10, which shows the achievable accuracy for a CRI blanking receiver. By comparison of the two figures it can be seen that modern eLoran signal processing considerably improves the positioning performance and results in much improved coverage, making eLoran available to mariners in more ports and harbours.

This work also made it possible to generate plots of the blanking loss distribution for a selected eLoran station within a given geographical area (for an example see Figure 11).

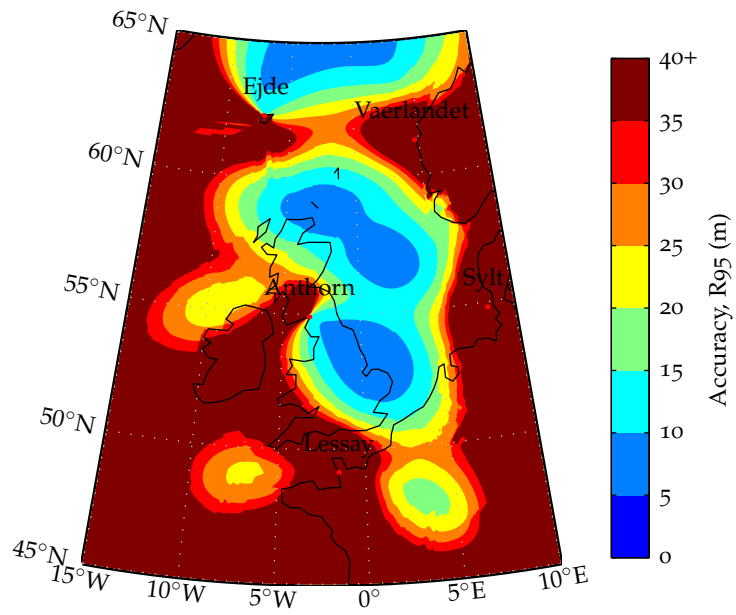

Figure 9: Daytime positioning accuracy for a linear receiver without CRI mitigation.

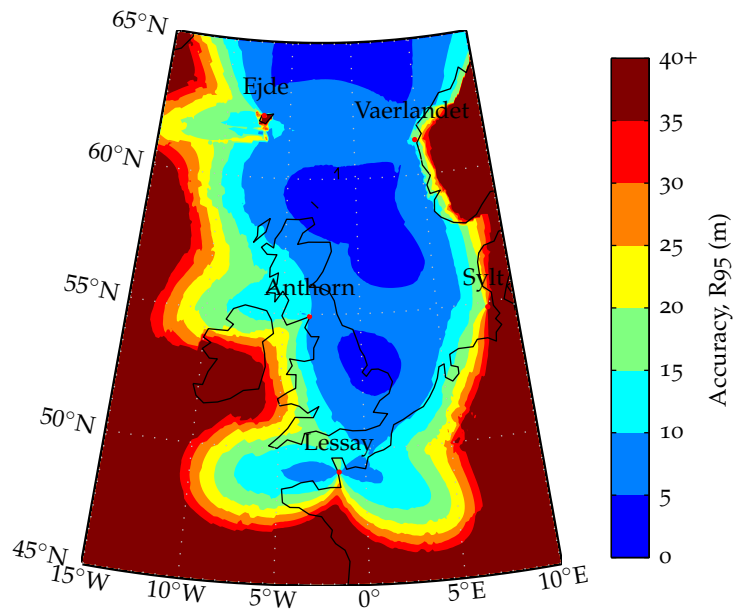

Figure 10: Daytime positioning accuracy with a CRI blanking receiver.

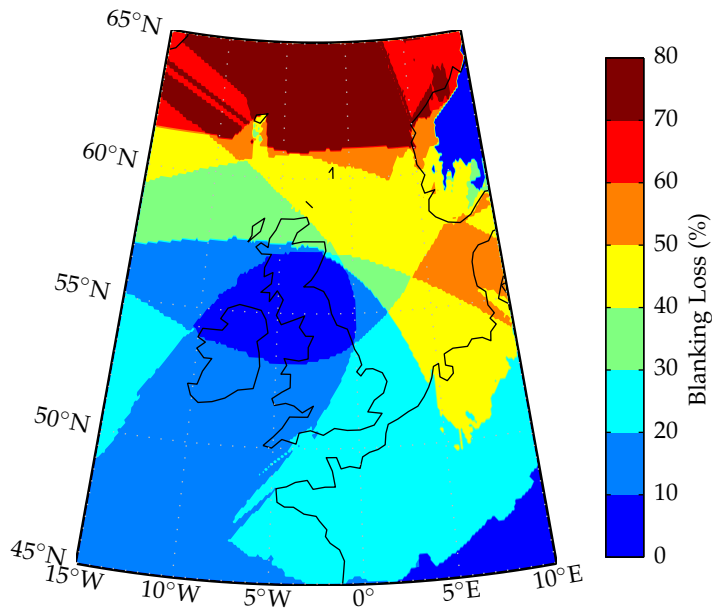

Figure 11: Blanking loss (daytime) for the 6731Y Anthorn station assuming a receiver that implements SIR sensitive CRI blanking.

GRI SELECTION

This study also examined the possibility of mitigating the effects of CRI through the judicious selection of the signal GRIs. GRI selection techniques used in establishing Loran-C chains were reviewed and a new GRI selection procedure was proposed which follows up on the methods used in the past, and introduces a number of eLoran updates, such as the use of modern eLoran signal processing techniques and the all-in-view positioning mode. The proposed procedure consists of the following five steps:

1. GRI preselection and Emission Delay assignment;
2. CWI analysis;
3. CRI analysis;
4. Coverage and performance optimisation;
5. Hardware simulation.

The new GRI selection procedure provides the answer to the second research question.

The use of the new procedure was demonstrated through a case study involving the addition of two new eLoran stations to the North-West European system. Several candidate GRIs for two new eLoran stations were identified and the merits and disadvantages of each were discussed. Figure 12 shows the predicted accuracy for the best GRI after the intended extension of the transmission network.

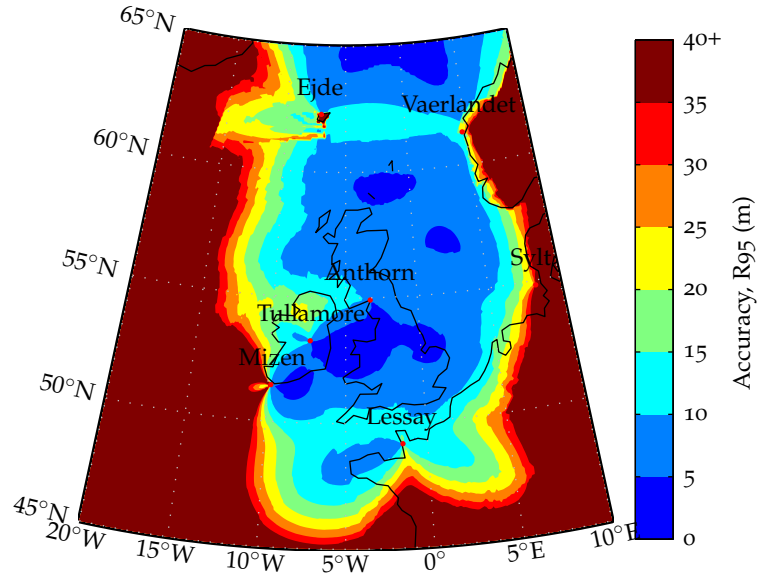

Figure 12: Average positioning accuracy with Tullamore and Mizzen Head, Ireland, on GRI 7499.

CONCLUSIONS

In summary, the following general conclusions can be drawn from this research:

- The effects of CRI are a function of a great number of parameters, including: Signal-to-Interference Ratio; Signal-to-Noise Ratio; GRIs and phase codes of the cross-rating signals; CRI mitigation algorithms used in the receiver; receiver integration time; the number of cross-rating GRIs and the number of stations within each GRI; and the time offset between the cross-rating signals (i.e. the position within the coverage area).
- Uncompensated CRI can introduce substantial measurement errors in linear receivers, including a position-dependent bias in the pseudorange measurements.
- State-of-the-art receiver signal processing can significantly mitigate the effects of CRI, however, a combination of several CRI mitigation techniques is required to achieve optimum results, and the residual impact on the measurement error generally cannot be considered negligible.
- The basic principles of GRI selection that applied to Loran-C apply equally to eLoran and can be used, when introducing a new eLoran station, to determine a set of candidate GRIs. The differences in performance between the different candidate GRIs when receiver CRI mitigation is applied are subtle and no general

rule can be given for the selection of the best GRI. It is proposed that the best GRI for a particular station's configuration is found through coverage and performance modelling, taking into account CRI and modern receiver signal processing algorithms.

REFERENCES

- [1] J. Clynych, "The Hunt for RFI - Unjamming a Coast Harbor," January 2003. (Cited on page 1.)
- [2] A. Grant, P. Williams, N. Ward, and S. Basker, "GPS Jamming and the Impact on Maritime Navigation," *The Journal of Navigation*, vol. 62, pp. 173–187, 2009. (Cited on page 1.)
- [3] M. Thomas, "Global Navigation Space Systems: reliance and vulnerabilities," tech. rep., The Royal Academy of Engineering, 2011. (Cited on page 1.)
- [4] John A. Volpe National Transportation System Center, *Vulnerability Assessment of the Transportation Infrastructure Relying on the Global Positioning System*, 2001. (Cited on page 1.)
- [5] International Loran Association, *Enhanced Loran (eLoran) Definition Document*, 2007. v. 1.0. (Cited on page 1.)
- [6] P. Williams, C. Hargreaves, D. Last, and N. Ward, "eLoran in the UK: Leading the Way," in *Proceedings of the ION Pacific PNT Conference*, April 2013. (Cited on page 1.)
- [7] W. F. Roland, "Loran-C Phase Code and Rate Manipulation for Reduced Cross Chain Interference," in *Proceedings of the 3rd Technical Symposium of the Wild Goose Association*, 1974. (Cited on pages 2 and 3.)
- [8] D. A. Feldman, P. E. Pakos, and C. E. Potts, "On the Analysis and Minimization of Mutual Interference of Loran-C Chains," in *Proceedings of the 4th Technical Symposium of the Wild Goose Association*, 1975. (Cited on pages 2 and 3.)
- [9] R. V. Gressang, I. G. G., and M. R. A., "A Case History of Reducing LORAN Chain Cross Rate Interference by Using a Balanced Phase Code," in *Proceedings of the 6th Annual Convention of the Wild Goose Association*, 1977. (Cited on page 3.)
- [10] R. S. Engelbrecht and A. Weisshaar, "The Effect of Cross-Rate Interference on LORAN-C Performance," in *Proceedings of the 15th Annual Technical Symposium of the Wild Goose Association*, 1986. (Cited on page 3.)
- [11] P. W. Schick, "Cross-Rate Interference Effects and Differential Loran Operation," in *Proceedings of the 25th Annual Technical Symposium, Wild Goose Association*, 1996. (Cited on page 3.)
- [12] V. J. P. Etten, "Reduction of Interference to LORAN-C," in *Proceedings of the 8th Annual Convention of the Wild Goose Association*, 1979. (Cited on page 3.)

- [13] R. Frank, "Polyphase complementary codes," vol. 26, no. 6, pp. 641–647, 1980. (Cited on page 3.)
- [14] R. L. Frank, "The Origin and Evolution of LORAN Phase Coding," in *Proceedings of the 10th Annual Technical Symposium of the Wild Goose Association*, 1981. (Cited on page 3.)
- [15] P. Swaszek, G. Johnson, R. Shalaev, and R. Hartnett, "Loran phase codes, revisited," in *Proc. IEEE/ION Position, Location and Navigation Symposium*, pp. 800–809, 2008. (Cited on page 3.)
- [16] A. K. Nieuwland and H. J. L. Arriens, "Determining Cross-Rate Interference for the North-West European Loran-C Chains," tech. rep., TU Delft, 1993. (Cited on page 3.)
- [17] A. K. Nieuwland, "GRI Ranking Based on Cross-Rate Interference in Loran-C," *The Journal of Navigation*, vol. 48, pp. 136 – 152, 1995. (Cited on page 3.)
- [18] M. Zeltser and M. El-Arini, "The Impact of Cross-Rate Interference on LORAN-C Receivers," vol. AES-21, no. 1, pp. 36–46, 1985. (Cited on page 3.)
- [19] A. Helwig, G. Offermans, and D. V. Willigen, "Implementation and Testing of Eurofix in Standard Loran-C Receiver Technology," in *Proceedings of the 25th Annual Technical Symposium, Wild Goose Association*, 1996. (Cited on page 3.)
- [20] B. Peterson, K. Gross, and E. Bowen, "Loran Receiver Structure for Cross Rate Interference Cancellation," in *Proceedings of 22nd Annual Technical Symposium of the Wild Goose Association*, 1993. (Cited on page 3.)
- [21] W. Pelgrum, "Noise - From a Receiver Perspective," in *Proceedings of the 34th Annual Convention and Technical Symposium of the International Loran Association*, 2005. (Cited on page 3.)
- [22] W. Pelgrum, *New Potential of Low-Frequency Radionavigation in the 21st Century*. PhD thesis, TU Delft, Delft, 2006. (Cited on pages 3 and 4.)
- [23] G. Johnson, M. Wiggins, P. F. Swaszek, L. Hartshorn, and R. Hartnett, "Possible Optimizations for the US Loran System," in *Proc. IEEE/ION Position, Location, And Navigation Symposium*, pp. 695–704, April 25–27, 2006. (Cited on page 3.)
- [24] M. Beckmann, *Carrier Wave Signals Interfering with Loran-C*. PhD thesis, TU Delft, 1992. (Cited on page 4.)
- [25] S. Lo, B. Peterson, C. Boyce, and P. Enge, "Loran Coverage Availability Simulation Tool," in *Proceedings of the Royal Institute of Navigation (RIN) NAVo8/ International Loran Association 37th Annual Meeting*, 2008. (Cited on pages 12 and 13.)

AUTHOR'S PUBLICATIONS

PUBLICATIONS RELATED TO THE SUBJECT OF THESIS

Peer-Reviewed Journals

- [A-1] J. Safar, P. Williams, and F. Vejrazka, "Accuracy Performance of eLoran Receivers under Cross-Rate Interference Conditions," *Annual of Navigation*, vol. 19, pp. 133–148, 2012. (Contribution 90%)
- [A-2] J. Safar, C. K. Lebekwe, and P. Williams, "Accuracy Performance of eLoran for Maritime Applications," *Annual of Navigation*, vol. 16, pp. 109–122, 2010. (Contribution 33%)
- [A-3] J. Safar, "eLoran - Společník družicové navigace?" *Slaboproudý obzor*, vol. 2, pp. 9–15, 2009.

Other

- [B-1] J. Safar, F. Vejrazka, and P. Williams, "Assessing the limits of eLoran positioning accuracy," in *Proceedings of the TransNav 2011 International Symposium on Marine Navigation and Safety of Sea Transportation*, A. Weintrit, Ed., Gdynia Maritime University. Gdynia, Poland: CRC Press/Balkema, June 2011, pp. 55–63, ISBN: 978-0-415-69113-0. (Contribution 90%)
- [B-2] P. Williams, C. Hargreaves, J. Safar, C. K. Lebekwe, G. Shaw, and N. Ward, "Resilient PNT in e-Navigation," in *Proceedings of the Royal Institute of Navigation NAV10 Conference and Exhibition*, 2010. (Contribution 5%)
- [B-3] J. Safar, "Group Repetition Interval Selection and Core eLoran Service Capacity," July 2010, presentation prepared for the meeting of Radio Technical Committee for Maritime Services (RTCM) Special Committee-127 in Harwich, UK, available as RTCM paper number 140-2010-SC127-082.
- [B-4] J. Safar, P. Williams, S. Basker, and F. Vejrazka, "Group Repetition Interval Selection and Core eLoran Service Capacity," in *Proceedings of the 13th IAIN World Congress*, Stockholm, 2009. (Contribution 85%)
- [B-5] J. Safar, P. Williams, S. Basker, and F. Vejrazka, "Cross-Rate Interference and Implications for Core eLoran Service Provision," in *Proceedings of the International Loran Association (ILA) 38th Annual Meeting*, Portland, ME, U.S., 2009. (Contribution 85%)
- [B-6] J. Safar, P. Williams, and S. Gug, "Group Repetition Interval Selection for eLoran," in *Proceedings of the Royal Institute of Navigation (RIN) NAVo8/ International Loran Association (ILA) 37th Annual Meeting*, London, UK, 2008. (Contribution 80%)

OTHER PUBLICATIONS

Publications Indexed by Web of Science

- [C-1] A. Grant, J. Safar, and M. Bransby, "Investigations into GPS Receiver Performance with an Increased Noise Floor Due to New Signals Broadcast from New and Amended GNSS Constellations," in *Proceedings of The Institute of Navigation GNSS+ Conference*, Tampa, Florida, September 2014. (Contribution 5%)
- [C-2] N. Ward, J. Safar, A. Grant, T. Kojima, and P. Mueller, "Enhanced Radar Positioning," in *Proceedings of the 2014 International Technical Meeting of The Institute of Navigation*, San Diego, California, January 2014, pp. 583–587. (Contribution 5%)
- [C-3] J. Safar, A. Grant, M. Bransby, N. Ward, "The Impact of Using Non-approved PNT Devices at Sea", in *Proceedings of the 2013 International Technical Meeting of The Institute of Navigation*, San Diego, California, January 2013, pp. 374–385. (Contribution 50%)

Other

- [D-1] J. Safar, D. Haley, A. Pollok, R. Luppino, A. Grant, and N. Ward, "VDES Channel Sounding Campaign," General Lighthouse Authorities of the UK and Ireland, Tech. Rep., 2014, available as Input Doc. No. 07 to the intersessional meeting of the IALA e-Navigation Committee Working Group 3/4, Saint-Germain-en-Laye, March 2014. (Contribution 30%)
- [D-2] J. Safar, N. Ward, D. Haley, A. Pollok, and R. Luppino, "VDES Channel Sounding Campaign," January 2014, presentation given at the Workshop on International Standardisation of VDES, Tokyo, Japan. (Contribution 50%)
- [D-3] C. Dixon, S. Smith, A. Hart, R. Keast, S. Lithgow, A. Grant, J. Safar, G. Shaw, C. Hill, S. Hill, and C. Beatty, "GNSS Vulnerabilities at Sea," *Coordinates magazine*, November 2013. (Contribution: 5%)
- [D-4] J. Safar, P. Thompson, "Investigations into AIS VDL Loading," General Lighthouse Authorities of the UK and Ireland, Tech. Rep., 2013, available as Input Doc. No. 25 to the intersessional meeting of the IALA e-Navigation Committee Working Group 3/4, Brest, September 2013. (Contribution 75%)
- [D-5] J. Safar, and N. Ward, "Communications for e-Navigation," December 2012, presentation given at the Workshop on International Standardisation of Next Generation AIS, Tokyo, Japan. (Contribution 50%)

INTERACTION WITH SCIENTIFIC COMMUNITY

During this work, the candidate has presented aspects of this study at numerous international conferences and actively participated in the meetings of the European eLoran Forum and the RTCM Special Committee 127 on eLoran systems. He was awarded the Best Student Paper Award for his presentations at the 2008 and 2009 Conventions of

the International Loran Association [B-6, B-5] and his work was also positively received within RTCM, where he is currently leading work on receiver testing.

The candidate has also participated in the meetings of the IALA⁵ e-Navigation Committee Working Group 3/4 and ITU-R⁶ Working Party 5B (WP 5B) which deal with maritime radiocommunication matters. His report [D-1] on VHF Data Exchange System (VDES) channel characterisation was adopted at the meeting of ITU-R WP 5B in Geneva, May 2014, as a new Report ITU-R M.[CHANNEL SOUNDING].

5 International Association of Marine Aids to Navigation and Lighthouse Authorities.

6 International Telecommunication Union, Radiocommunication Sector

SUMMARY

The thesis addressed questions that arise when considering the introduction of new eLoran stations into an existing network. Specifically, the following questions:

1. What is the effect on accuracy performance within a coverage region when a new eLoran station is installed, given the increase in Cross-Rate Interference (CRI) and a modern eLoran receiver's ability to cope with such interference through blanking or cancelling of interfering pulses?
2. What is the best method for selecting a Group Repetition Interval (GRI) for a new station installation given modern eLoran technology, including receiver signal processing techniques?

In answer to the first research question, it was found that the effects of CRI are dependent on a great number of signal parameters and on the choice of receiver signal processing algorithms. It was shown that uncompensated CRI can introduce substantial measurement errors, including a position-dependent bias in the pseudorange measurements. It was further found that state-of-the-art receiver signal processing can significantly mitigate the effects of CRI, however, a combination of several CRI mitigation techniques is required to achieve optimum results, and the residual impact on the measurement error generally cannot be considered negligible.

In answer to the second research question, it was concluded that the basic principles of GRI selection that applied to Loran-C apply equally to eLoran and can be used, when introducing a new eLoran station, to determine a set of candidate GRIs. The differences in performance between the different candidate GRIs are subtle when receiver CRI mitigation is applied and no general rule can be given for the selection of the best GRI. It was proposed that the best GRI for a particular station's configuration is found through coverage and performance modelling, taking into account CRI and modern receiver signal processing algorithms.

Prior to this research it was not possible to accurately quantify the effects of CRI on the coverage and performance of eLoran systems, and GRI selection procedures were only available for the precursor of eLoran, Loran-C. In this work, analytical models of the pseudorange and positioning error due to CRI have been developed, validated and integrated into a coverage prediction tool. As part of this work, an eLoran signal simulator has been developed to enable the candidate to verify the analytical models through receiver performance testing in a controlled radio environment. A review of existing GRI selection methods has also been carried out and a new procedure has been proposed, implementing several important eLoran updates. The tools developed have been used to assess the impact of CRI within the North-West European region and suggest optimal GRIs for two new stations in Ireland. The results should prove to be of great value to the General Lighthouse Authorities of the United Kingdom and Ireland, as they look to implement eLoran across their service area.

RÉSUMÉ

Předkládaná práce se zabývá otázkami spojenými se zaváděním nových vysílacích stanic systému eLoran. Konkrétně následujícími otázkami:

1. Jaký vliv má zavedení nové stanice systému eLoran na přesnost určení polohy v oblasti pokrytí, s ohledem na nárůst vlastního rušení a moderní metody zpracování signálu umožňující toto rušení potlačit?
2. Jakým způsobem by měly být přiřazovány opakovací intervaly pro nové stanice systému eLoran, s ohledem na v současnosti dostupné technologie a metody zpracování signálu?

Co se týká první výše uvedené otázky, tato studie prokázala, že výsledný vliv vzájemného rušení významně závisí na řadě parametrů přijatého signálu a na volbě algoritmů zpracování signálu. Autor ukázal, že nekompensované vzájemné rušení může vyvolat značnou chybu měření a ovlivnit střední hodnotu měřených pseudovzdáleností. Dále bylo ukázáno, že současné metody zpracování signálu umožňují vliv vzájemného rušení do značné míry potlačit, nicméně, pro dosažení optimálních výsledků je nutné použít kombinace několika různých algoritmů a výsledná chyba měření obecně není zanedbatelná.

Co se týká druhé výše uvedené otázky, tato práce ukázala, že základní principy výběru opakovacích intervalů používané v systému Loran-C (předchůdce eLoranu) jsou platné i pro eLoran a při zavádění nové stanice eLoranu je možné tyto principy použít pro stanovení skupiny vhodných opakovacích intervalů. Tato studie dále ukázala, že při použití moderních metod zpracování signálu jsou rozdíly ve vlivu vlastního rušení na výkonostní parametry systému mezi jednotlivými potenciálními opakovacími intervaly velmi malé. Autor navrhuje, aby optimální opakovací interval pro danou konfiguraci vysílacích stanic byl stanoven pomocí modelů pokrytí (rovněž popsanych v předkládané práci), které zahrnují vliv vlastního rušení a moderních metod zpracování signálu.

Hlavní přínos předkládané práce spočívá v odvození modelů umožňujících přesně kvantifikovat vliv vlastního rušení na pokrytí a přesnost systému eLoran a v návrhu optimální metody výběru opakovacích intervalů pro nové vysílací stanice. Navrhované modely chyb měření pseudovzdáleností a polohy vlivem vlastního rušení byly ověřeny simulací a experimentálně a následně byly začleněny do software pro modelování pokrytí. Součástí této práce byl vývoj simulátoru signálu systému eLoran, umožňujícího ověřit analyticky odvozené modely pomocí experimentů s komerčně dostupnými přijímači. Dále byly přezkoumány existující metody výběru opakovacích intervalů pro Loran-C a byla navržena nová procedura pro eLoran. Nástroje vyvinuté během této práce byly použity pro vyhodnocení vlivu vlastního rušení v evropském systému stanic a návrh optimálních opakovacích intervalů pro dvě nové stanice v Irsku. Výsledky předkládané práce by měly poskytovat cenné informace pro General Lighthouse Authorities (Spojené Království a Irsko), které v současnosti plánují implementaci eLoranu v Britských vodách.