

## HOLEŠOVICE WELLNESS CENTER SPA



## CONTENT

- 01 INTRODUCTION
- 02 REFERENCES
- 03 ANALYSIS
- 04 DESIGN
- 05 BIBLIOGRAPHY

ASSIGNMENT OF THE DIPLOMA PROJECT

lázně- spa

a mineral spring;  
a resort with mineral springs  
a commercial establishment providing facilities  
devoted especially to health, fitness, weight loss, and relaxation  
a health club

The term is derived from the name  
of the Belgian town of Spa, where  
since medieval times illnesses caused  
by iron deficiency were treated by  
drinking chalybeate  
(iron-bearing) spring water.

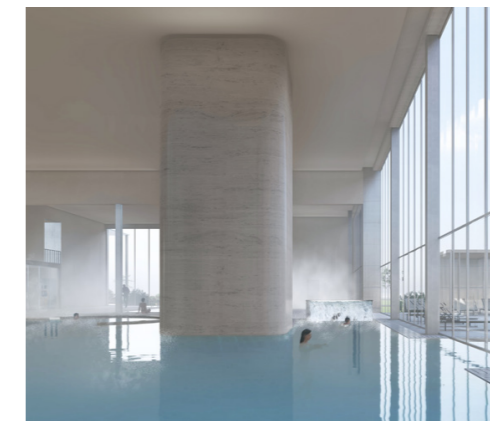

The purpose of the diploma project is  
to integrate contemporary wellness  
treatments with the Czech spa  
traditions, that are deeply rooted into  
the country's history, contributing  
both the city's identity and the well-  
being of residents and visitors of the  
city.

## SPAS IN CZECH REPUBLIC

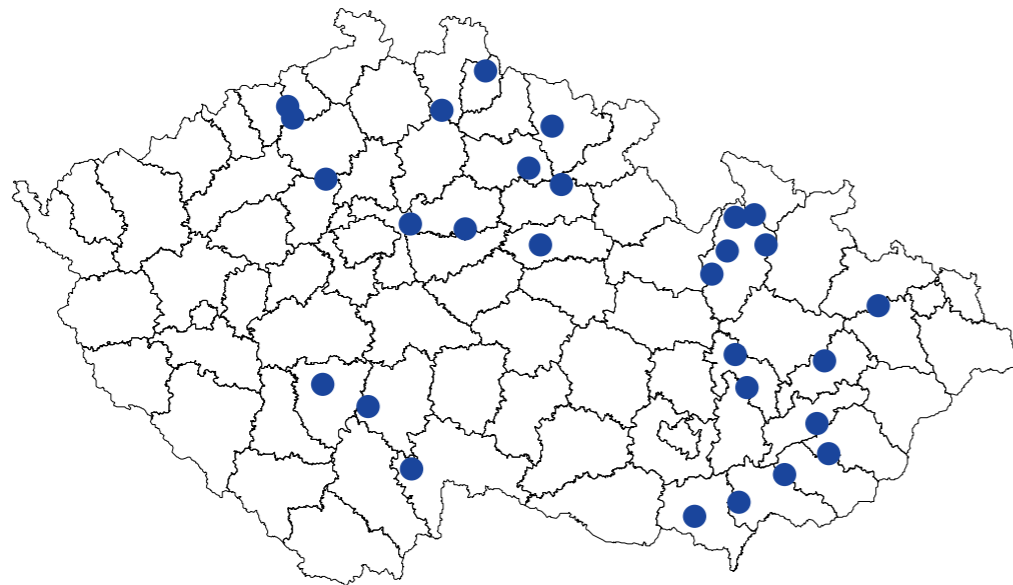

Geographically, the Czech Republic is rich in mineral waters, which have always been utilized by its people. The significance of Czech lázně (spas) holds a prominent place in the nation's history. The map indicates biggest spa resorts and towns in the country.

### Emperal Bath, Karlovy Vary

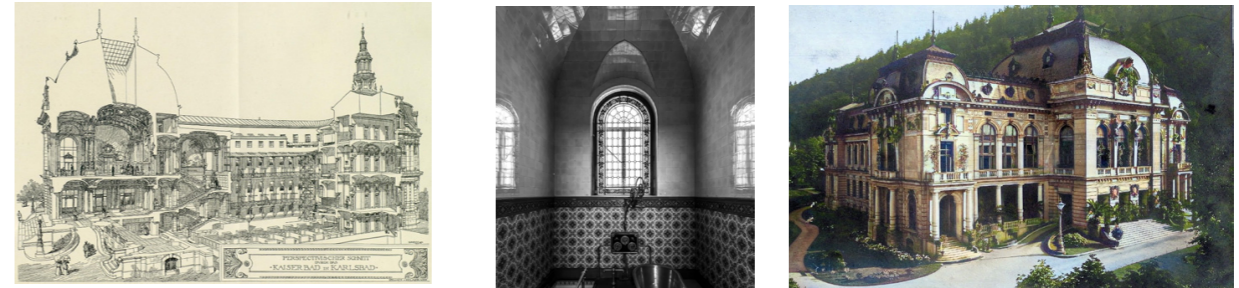

### Františkovy Lázně, Cheb



### Public spa in Brno-Zábřovice, Bohuslav Fuchs



The Padel Club by Healy Partners Architects. Hotel, spa

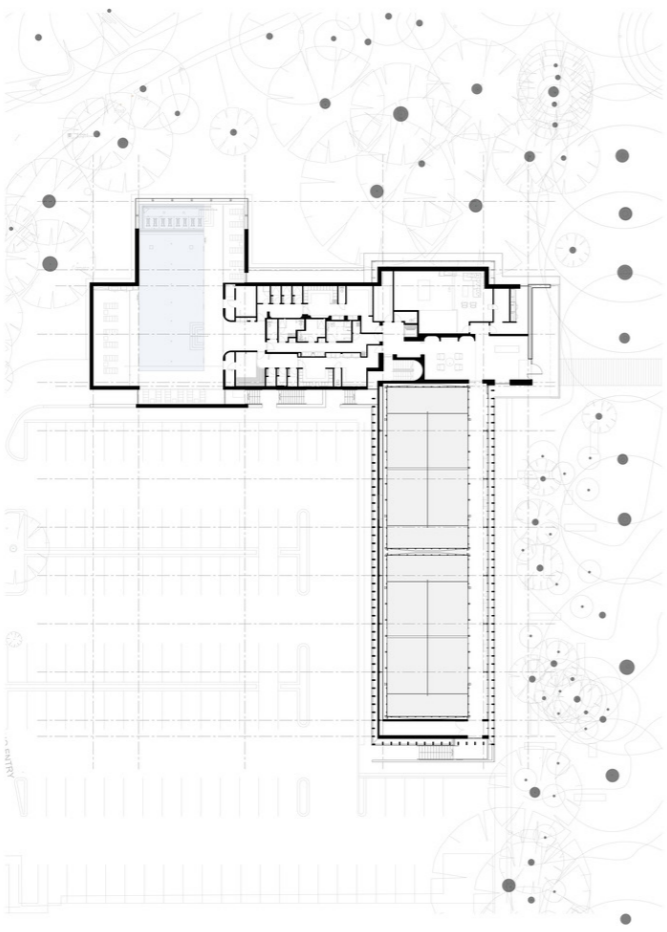

Strøm Nordic Spa by Lemay Michaud Quebec City

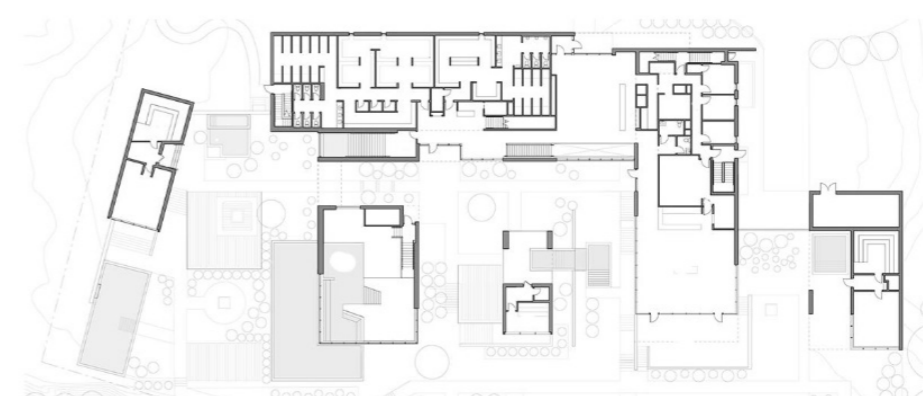
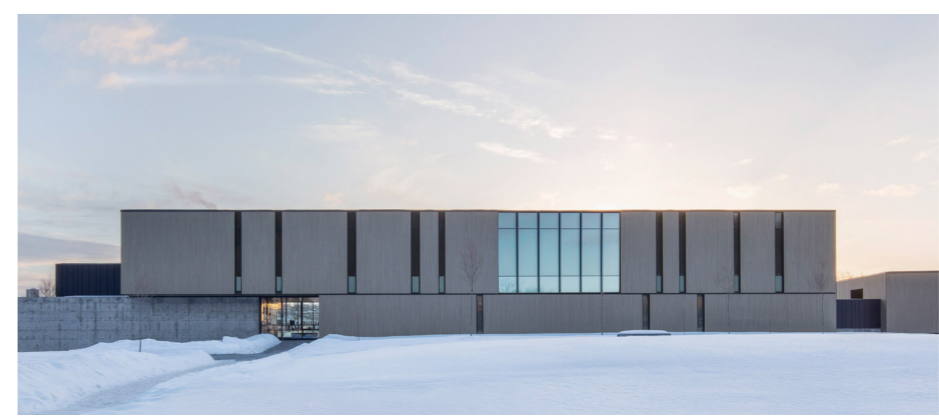
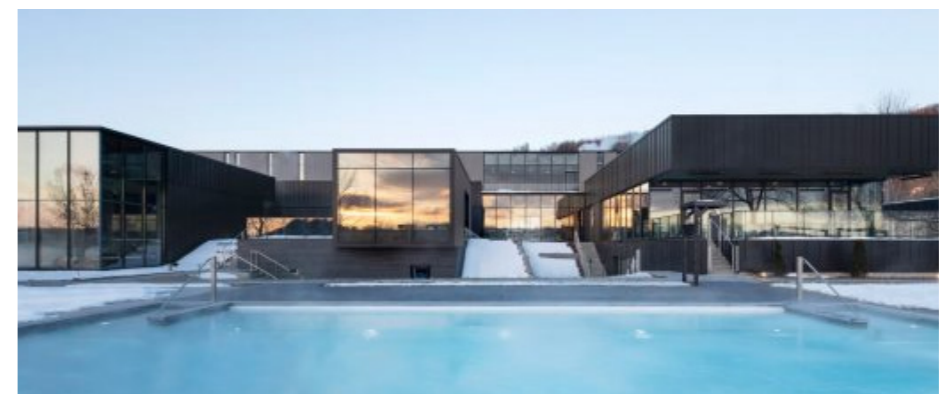

Therme Vals , spa by  
Peter Zumthor in Switzerland

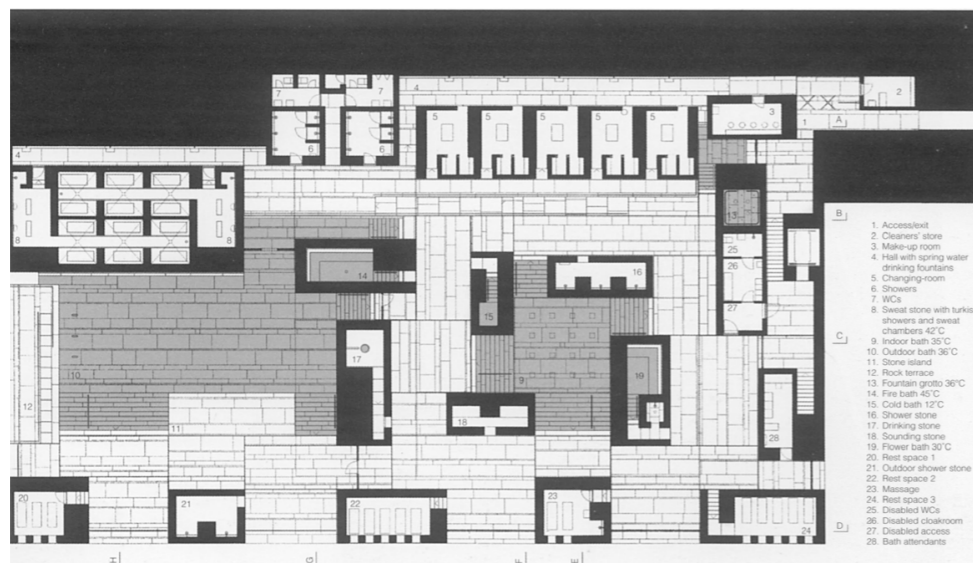

Aquatic Centre Les Bains des Docks in  
Le Havre, France, by Jean Nouvel

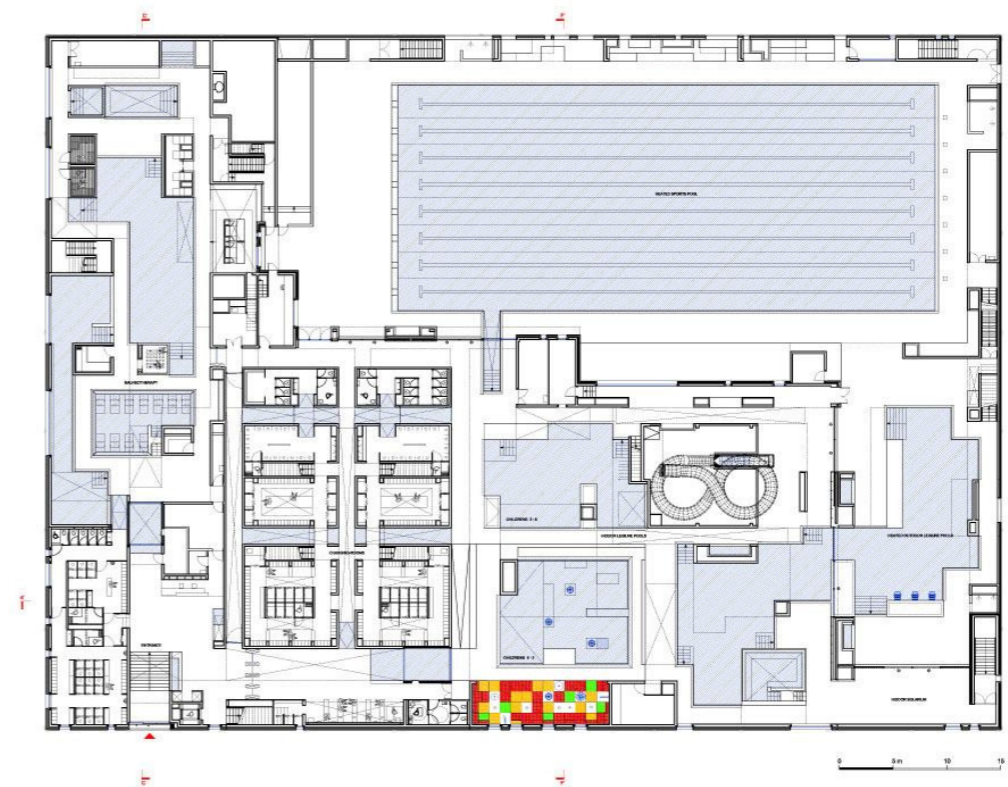

## LOCATION



The project is situated in Holešovice, previously an industrial district of Prague that has witnessed a number of urban changes over the years. The spa is positioned near the historically significant marketplace, Holešovická tržnice, along the riverfront of the Vltava River, overlooking Karlín.

## SPAS IN PRAGUE

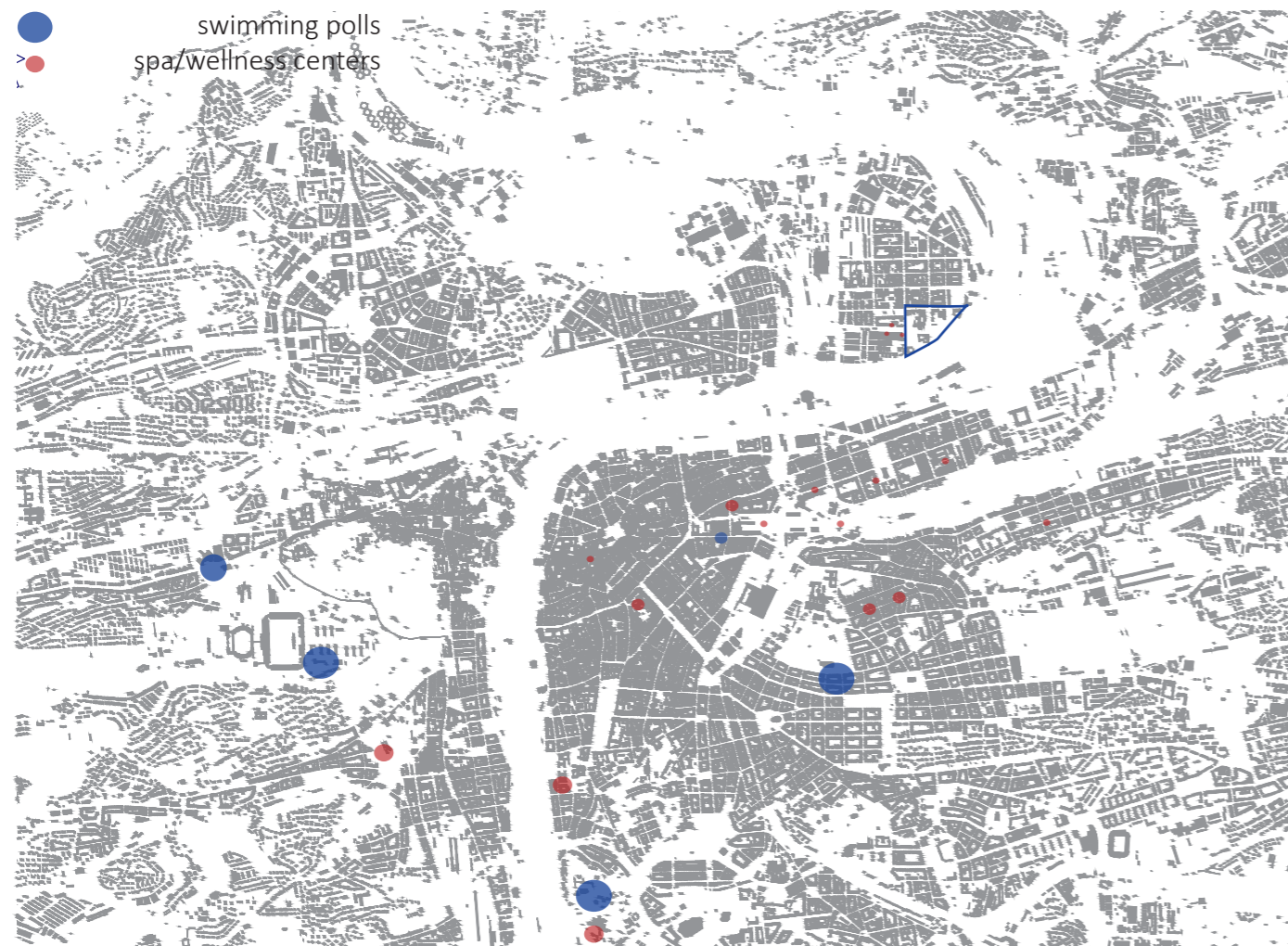

The map indicates various spas and wellness centers dispersed around the city. Most prominent include indoor swimming pool 50m- Plavecký stadion Podolí in Prague 4, Swimming lake Džbán (Divoká Šárka).

## HOLEŠOVICE

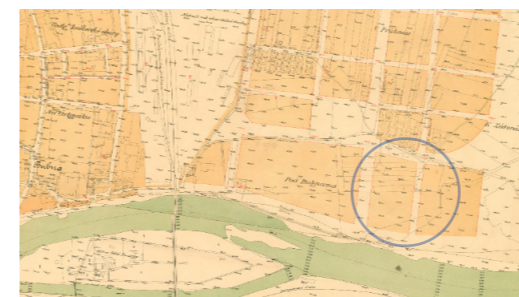

1889



1909



2024

Project area is located in Holešovice- district in the north of Prague situated on a meander of the River Vltava, which makes up the main part of the district Prague 7.

In the past it was a heavily industrial suburb; today it is home to the main site of the Prague's National Gallery in Veletržní palác, the DOX Center for contemporary art, and National Technical Museum.

It is located near near the Holešovická tržnice-a heritage-protected area in the southern part in the bend of the picturesque Vltava meander. Formerly industrial buildings offer a variety of retail, arts and dining facilities.

Historically a distinct town, Holešovice was originally founded in the 13th century and later became a part of Prague in the late 19th century. The area has witnessed various economic and industrial transformations throughout its history.

In the late 19th and early 20th centuries, Holešovice developed into an industrial hub, characterized by factories and warehouses.

During the 20th century, Holešovice experienced periods of urbanization and industrial development, contributing significantly to the city's economic landscape. However, in the latter half of the century it faced deindustrialization. In recent decades, former industrial spaces have been repurposed into cultural venues, galleries, and residential areas.



THE SITE



S  
 New developing area- many attractions DOX museum, Market, new pedestrian bridge, Letna park, Vystavište (Exhibition Grounds), National gallery  
 Connections- train station, Vltavska metro station  
 Views  
 Nature- river, vegetation  
 Location within the city  
 HolKa- connection between Karlin and Holešovice



W  
 Parking lot  
 Neglected areas

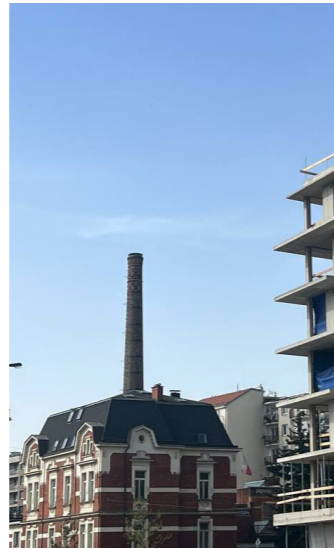

O  
 Riverbank  
 New developing area  
 Use of terrainw

T  
 Concrete production  
 Noise, pollution  
 Floods

LAND USE



- residential
- parks
- landfills
- services
- administrative
- industry
- market
- public

VEGETATION



- public parks
- sports and leisure

HEIGHTS



- 1-2 floors
- 3-4 floors
- 5-9 floors
- 6-15 floors

FLOOD PROTECTION

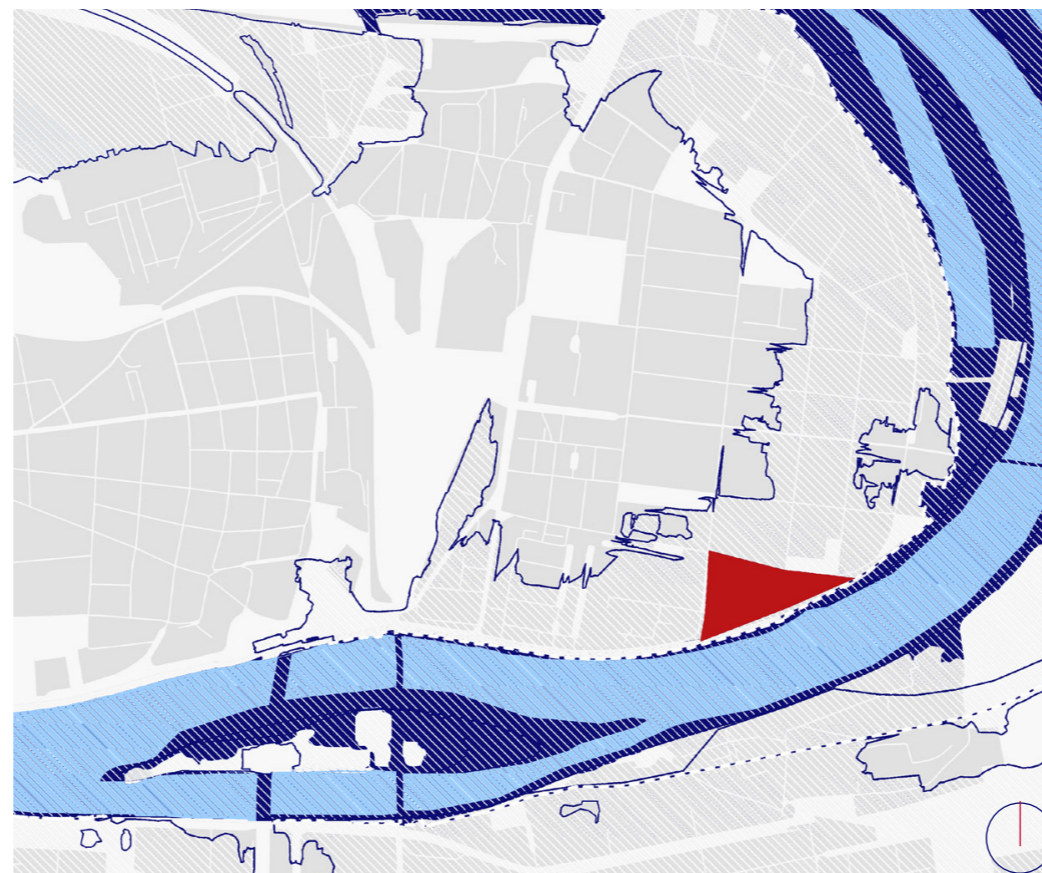

- Vltava river
- Vltava 100 years
- flood 2013
- - - flood protection

TRANSPORTATION

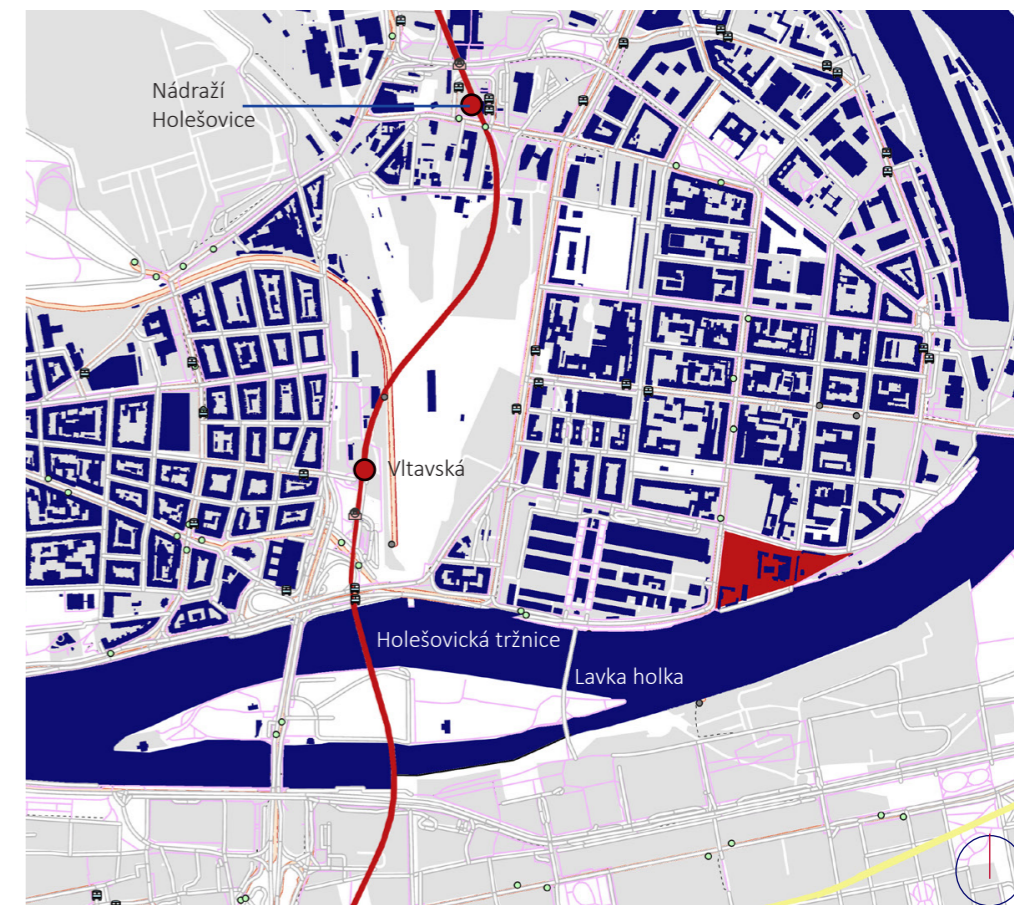

- metro A
- metro B
- pedestrian routes
- public transport
- tram stops
- metro station

TERRAIN

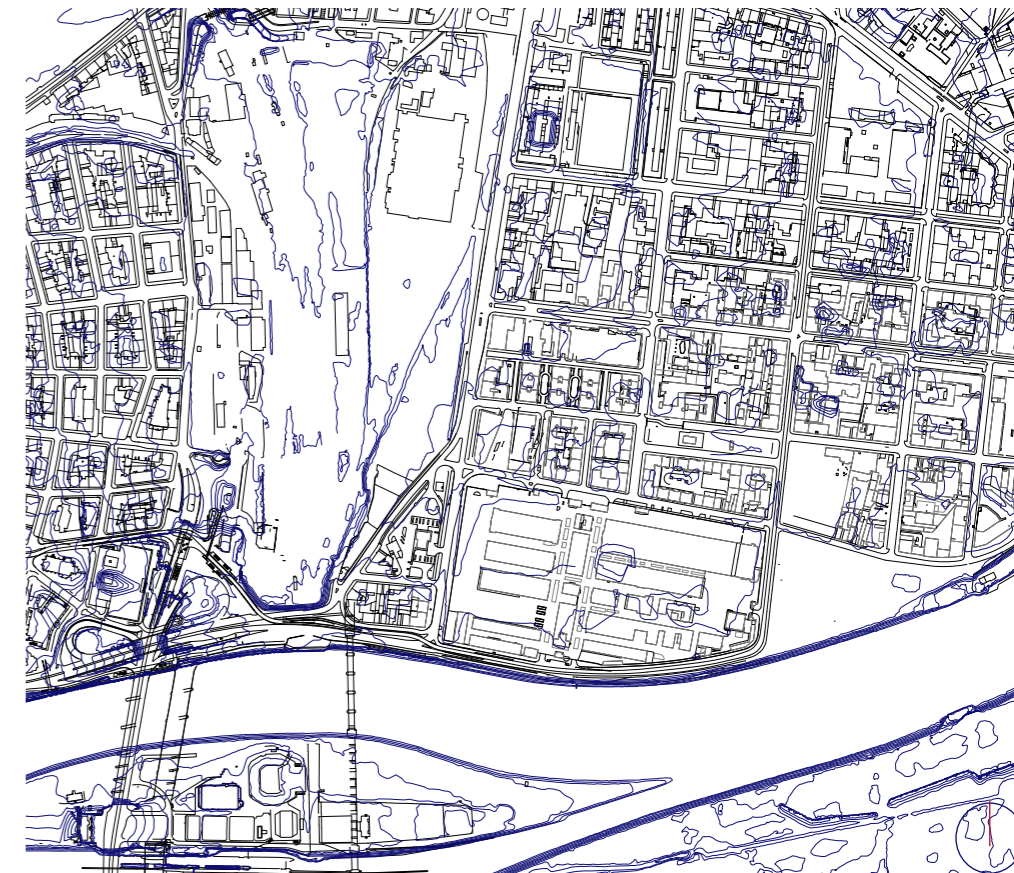

- contours



Vibrant industrial history of the former Holešovice and the site location at the riverbank were the key points in the diploma design.

The main factor that determined the building's position on the plot was ensuring free access to the river. Currently, a large parking lot and fences from surrounding buildings block the river view.

One peculiarity noticeable in Holešovice is peeking former chimneys which are seen all across the area. This is how the 4 «chimneys» appeared above the spa.

Made of concrete shell, one chimney serves as an external shaft for air ventilation. Other three- are skylights providing natural sunlight into the hamamm and saunas.

The interior configuration of the spa revolves around two pools: a 30-meter sports swimming pool and a lounge pool. Huge column like warm rooms are placed inside the water, serving as additional ventilation shafts as well. The large pool area is formally connected to a spacious atrium above, allowing sunlight to shine on the water. The zoning follows a conventional pool typology, with separate changing rooms and showers divided by a corridor from the spacious vestibule with an atrium.

## CONCEPT

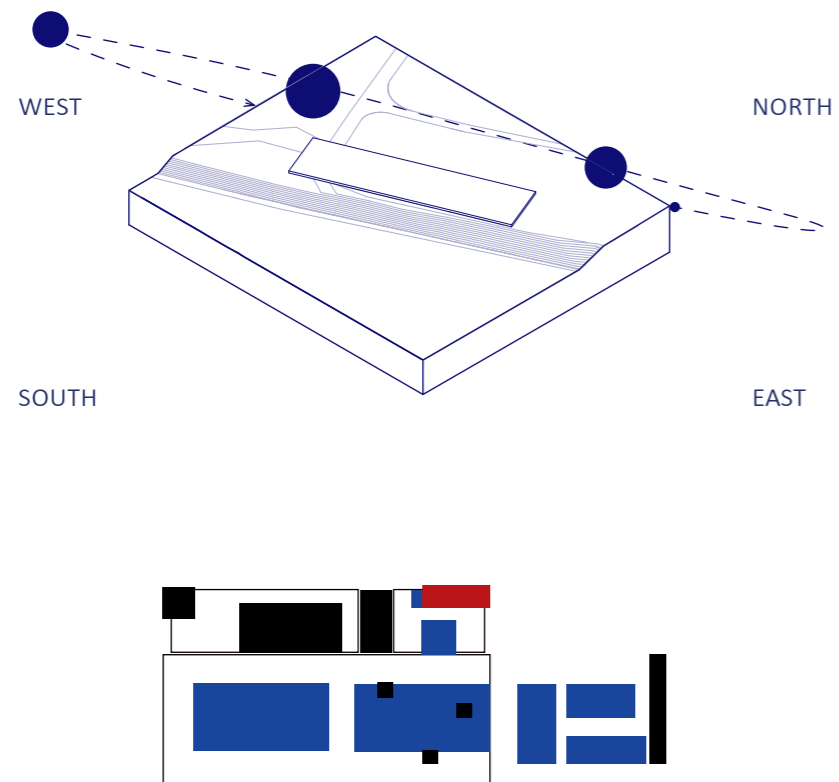

The main entrance is positioned on the northern side, which remains mostly in the shadow during the day. The pools are oriented completely to the south to preserve the panoramic view of the river. The extensive exposure to the sun through the almost fully glass facades is eliminated by energy-efficient, high-quality glazing systems and automatic internal blinds.

The facade with the public promenade receives intense sunlight for most of the day, with the sun nearly overhead at its zenith. To address this, a canopy extends along the entire riverfront. The spaces adjacent to the promenade benefit from this design approach. A large canopy adjacent to the southern facade addresses the intense sunlight during the day.

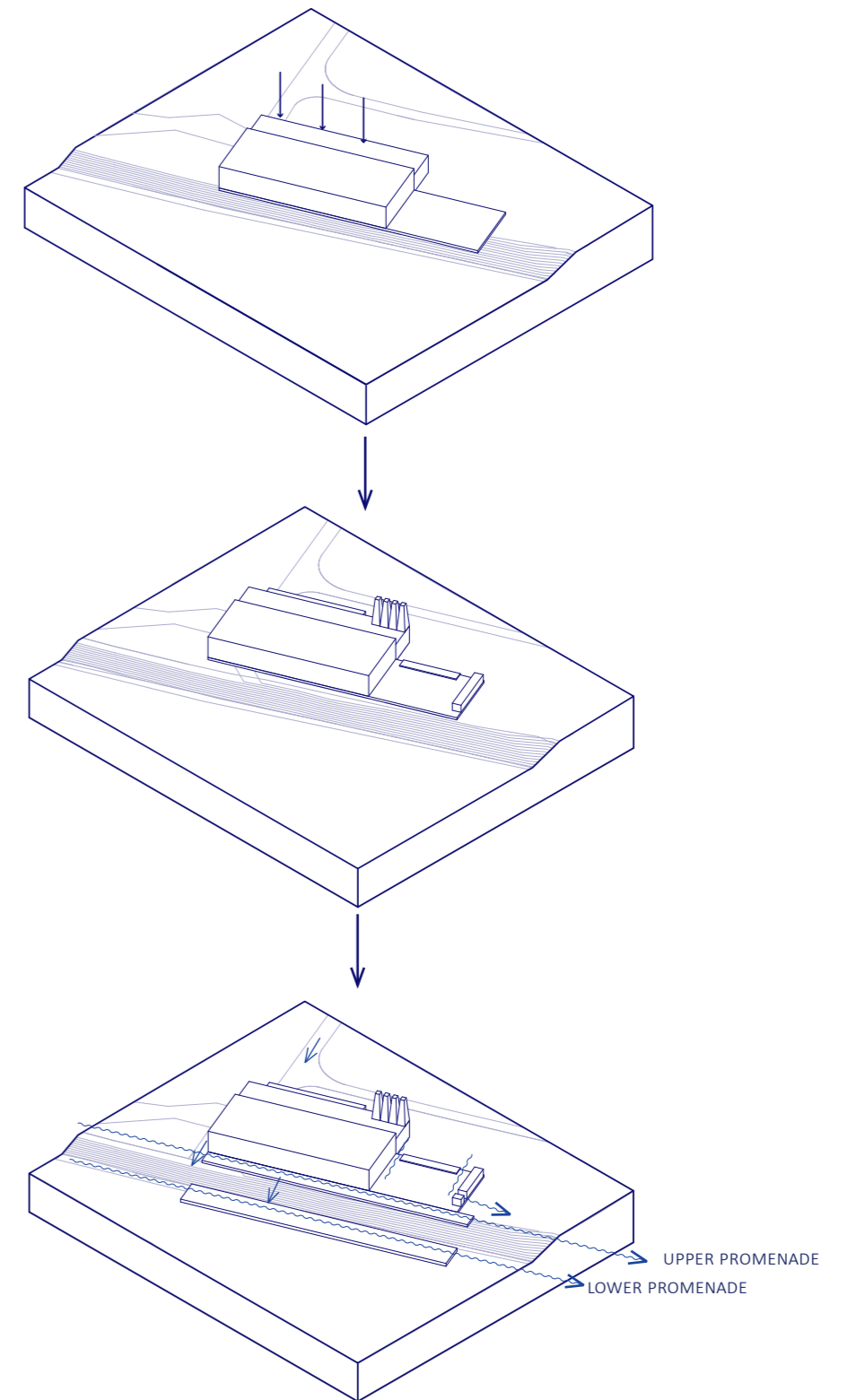

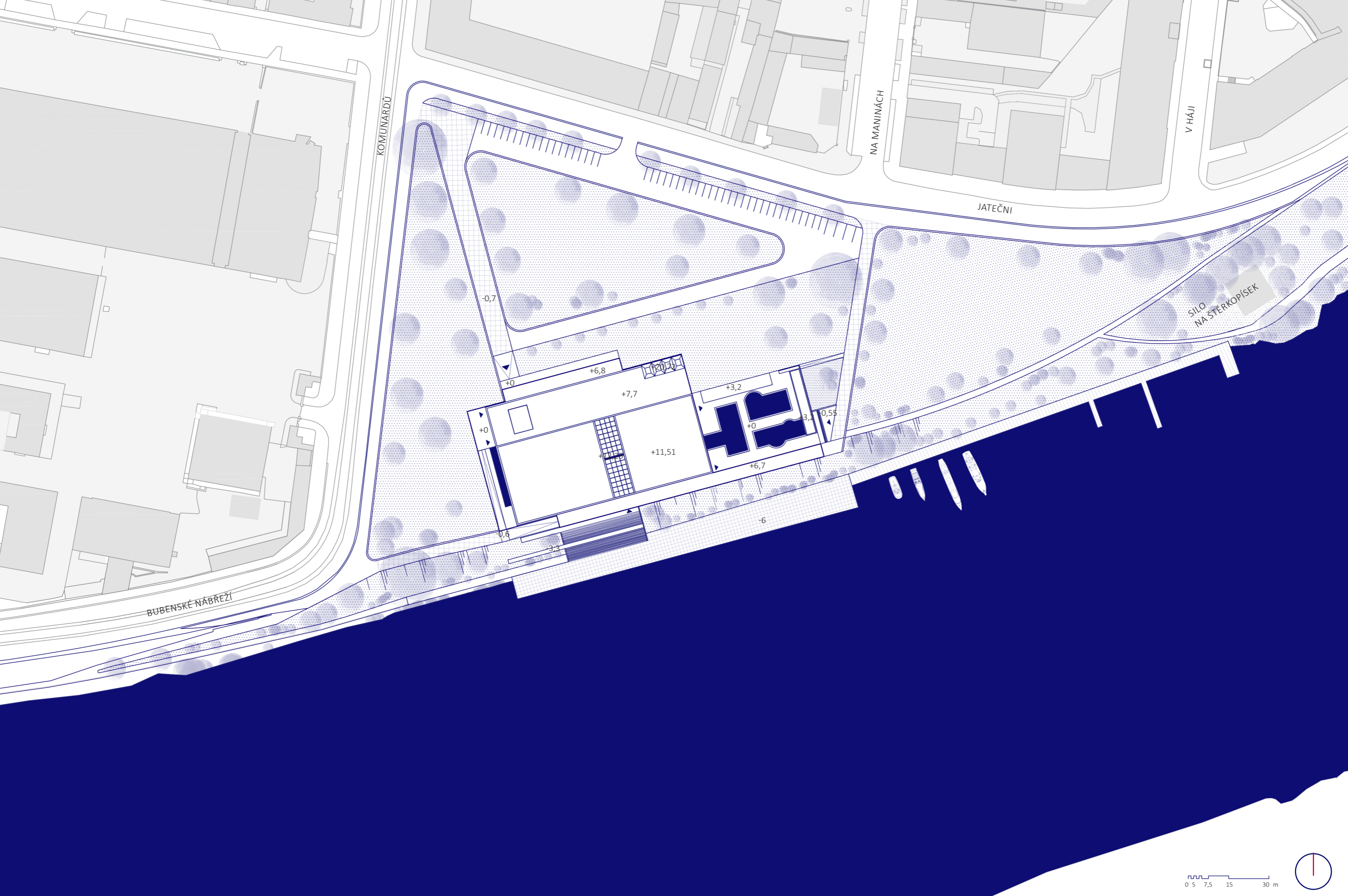

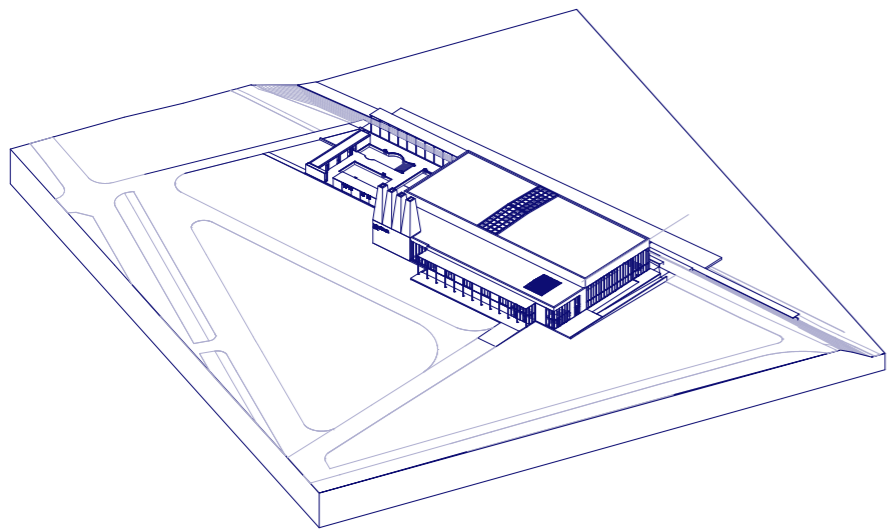

The building is positioned close to the river with a slight setback to create a public promenade in front of the southern facade. Additionally, this creates a separation between the public and private zones of the riverbank and the actual spa, which has restricted access. The entire building is raised 1 meter high to better adjust to the terrain and utilize the southern slope descending to the river.

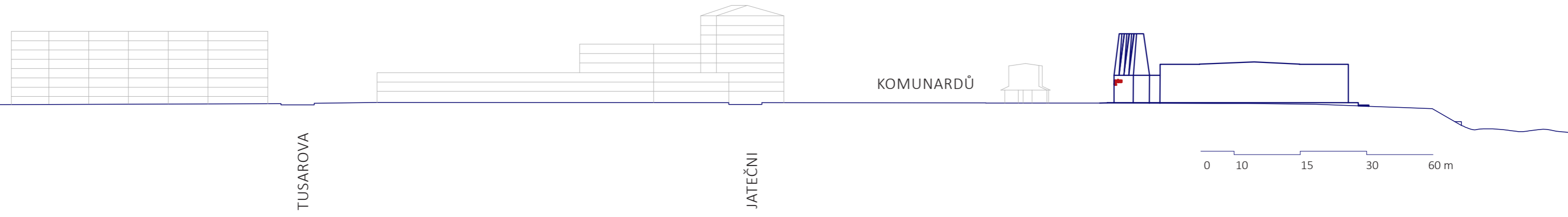
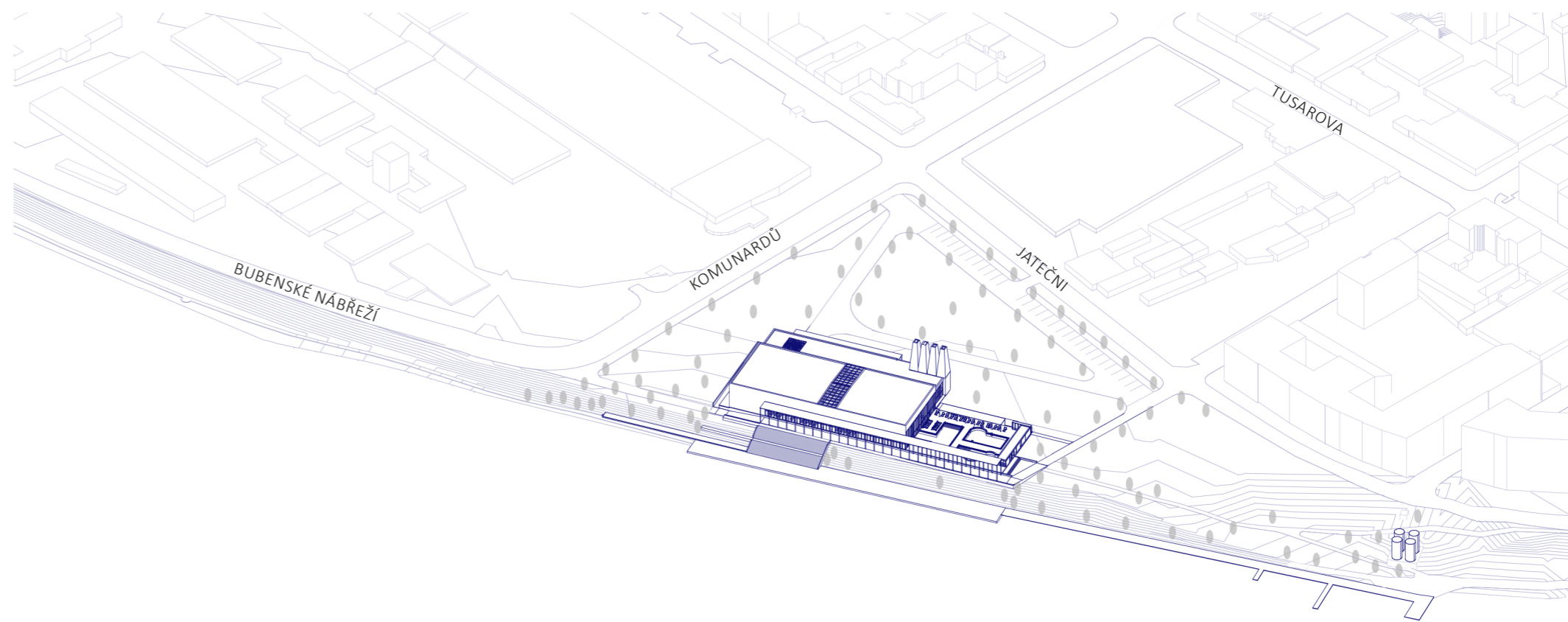

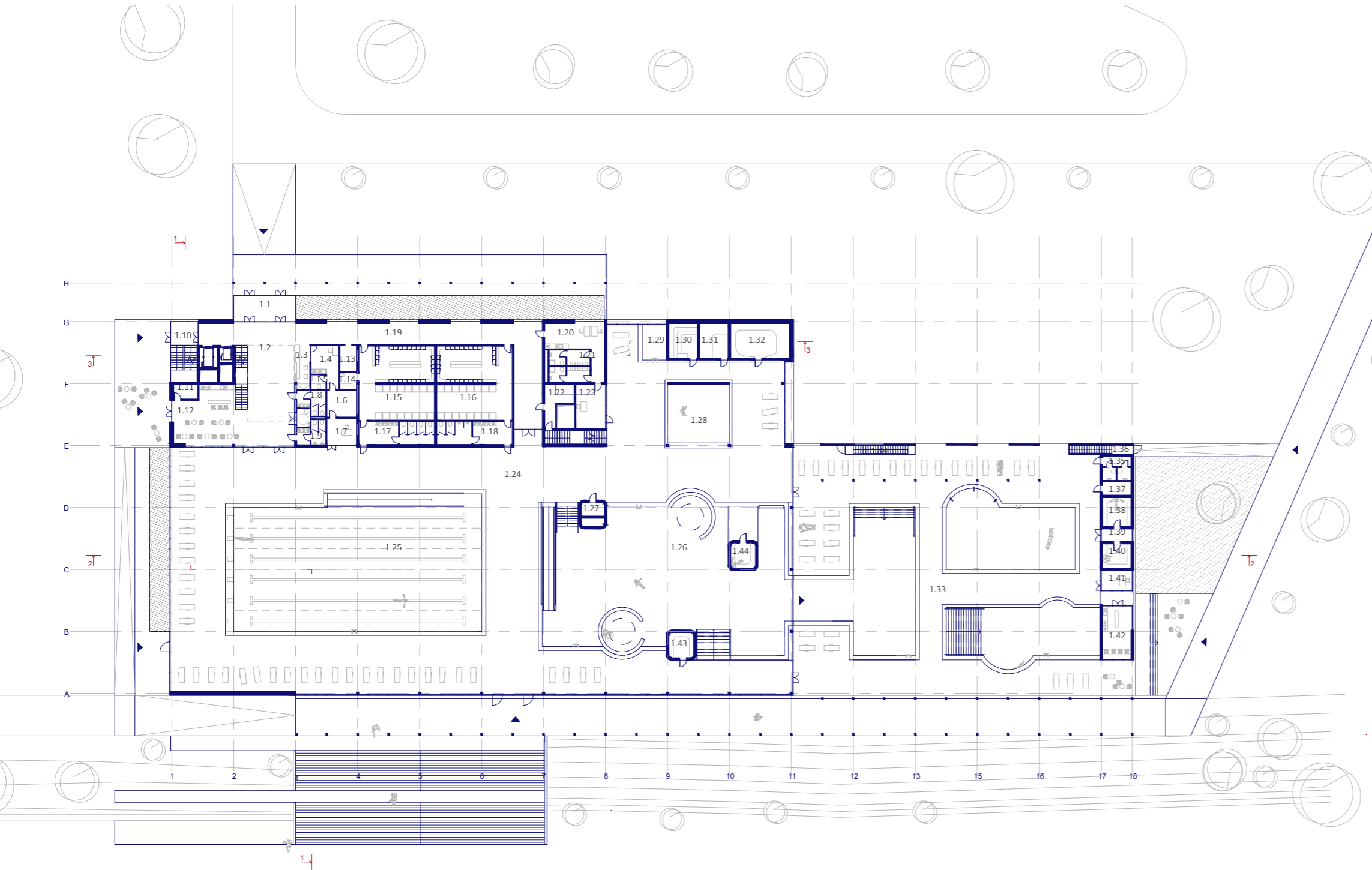

- 1.1 Airlock
- 1.2 Vestibule
- 1.3 Reception
- 1.4 Staff room
- 1.5 Staff WC
- 1.6 Storage
- 1.7 Life guard room
- 1.8 Women WC
- 1.9 Men WC
- 1.10 Fire escape staircase
- 1.11 Storage
- 1.12 Cafeteria
- 1.13 Storage
- 1.14 Toddlers changing room
- 1.15 Women changing room
- 1.16 Men changing room
- 1.17 Women WC
- 1.18 Men WC
- 1.19 Pool enclosure
- 1.20 Staff office
- 1.21 Pool staff changing room
- 1.22 Technical room
- 1.23 First aid office
- 1.24 Pools area
- 1.25 Sports swimming pool
- 1.26 Leisure swimming pool
- 1.27 Warm steam room
- 1.28 Kids pool
- 1.29 Cold water tank
- 1.30 Sauna
- 1.31 Steam sauna
- 1.32 Hammam
- 1.33 Outside warm pools
- 1.34 Basement staircase
- 1.35 WC
- 1.36 Basement staircase
- 1.37 Caleaning storage
- 1.38 Sauna
- 1.39 Airlock
- 1.40 Cold sauna
- 1.41 Life guard office
- 1.42 Cafe
- 1.43 Salt chamber
- 1.44 Bio sauna

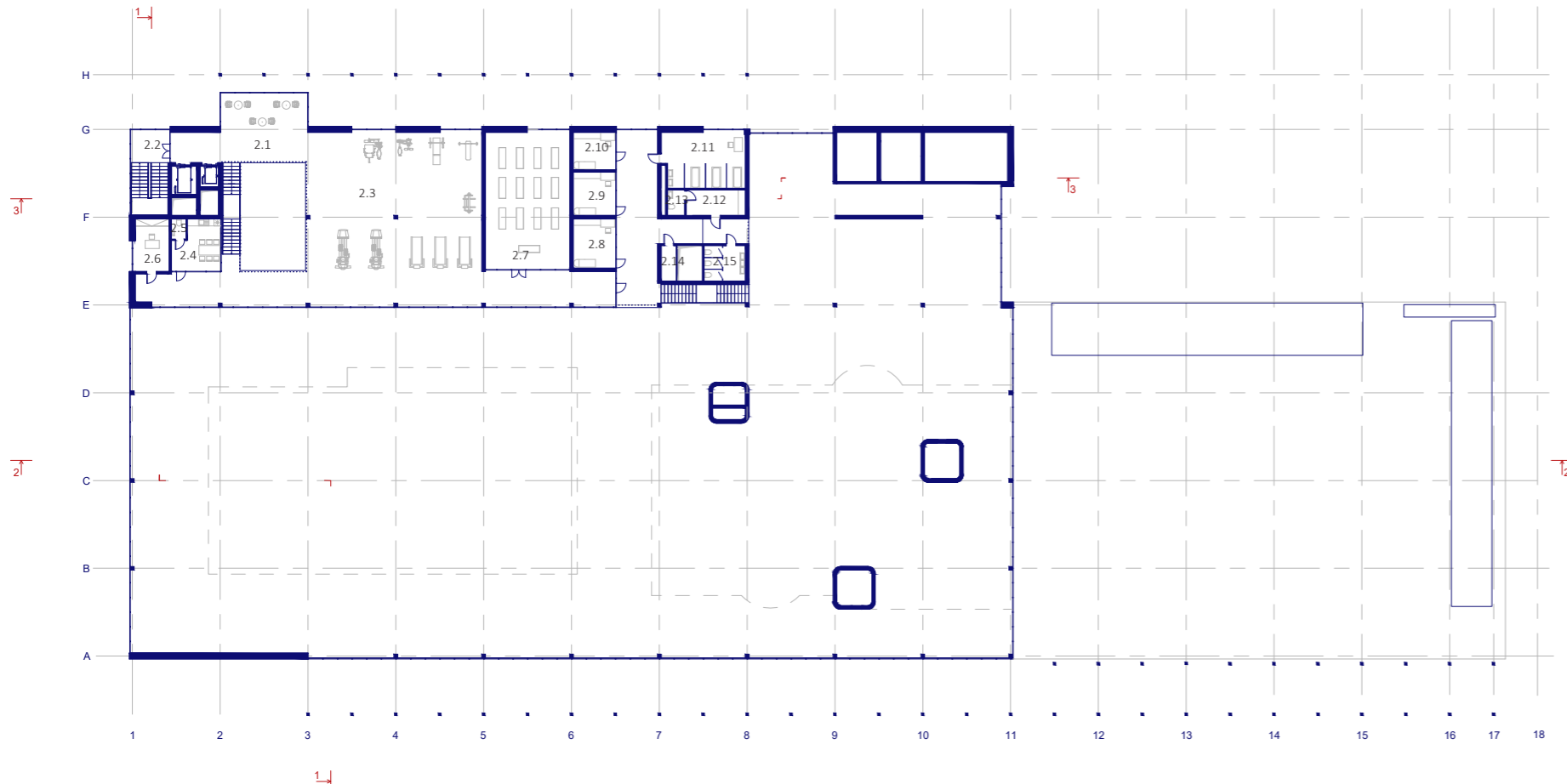

- 2.1 Vestibule
- 2.2 Fire escape staircase
- 2.3 Gym
- 2.4 Staff room
- 2.5 WC
- 2.6 Administration office
- 2.7 Yoga room
- 2.8 Massage
- 2.9 Massage
- 2.10 Massage room
- 2.11 Physio therapy
- 2.12 Staff changing room
- 2.13 Staff WC
- 2.14 Storage
- 2.15 WC

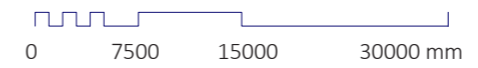





- 1.1 Service corridor
- 1.2 Laundry room
- 1.3 Storage
- 1.4 Storage
- 1.5 Storage
- 1.6 Storage
- 1.7 Technical room
- 1.8 Technical room
- 1.9 Technical room
- 1.10 Technical room
- 1.11 Technical room
- 1.12 Technical room
- 1.13 Technical room
- 1.14 Technical room
- 1.15 Technical room
- 1.16 Service corridor
- 1.17 Outside pool entrance
- 1.18 Service corridor

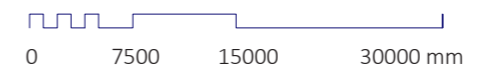

SECTIONS

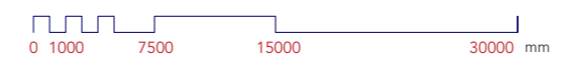
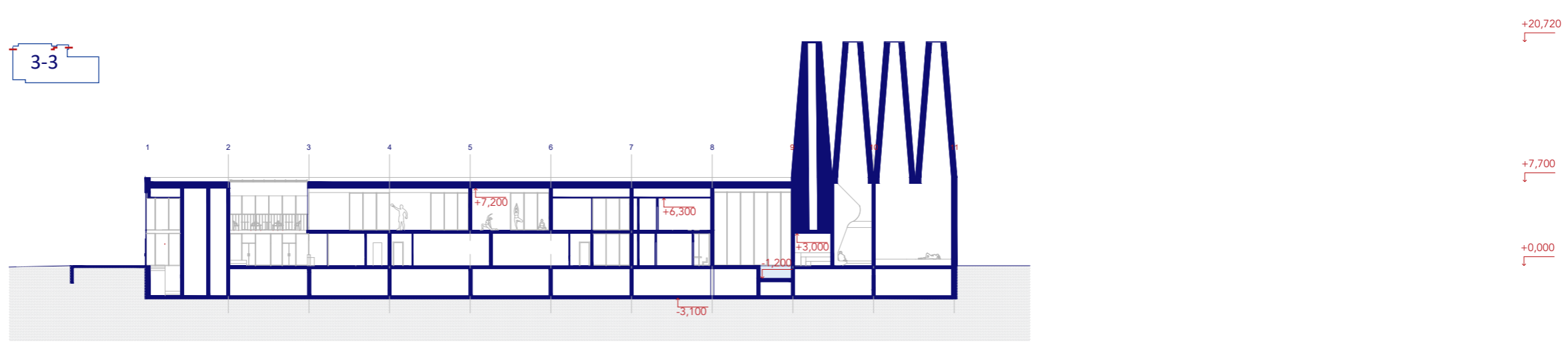
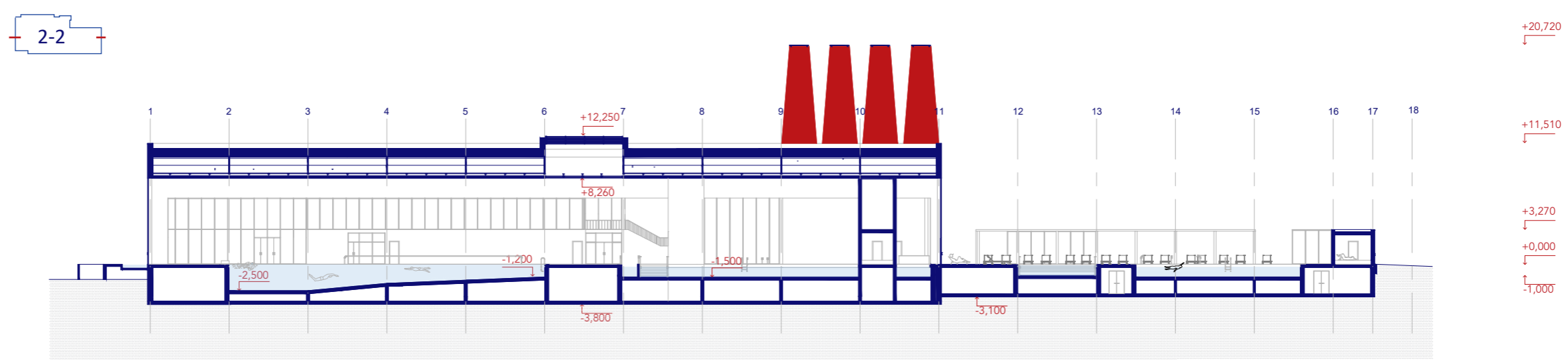
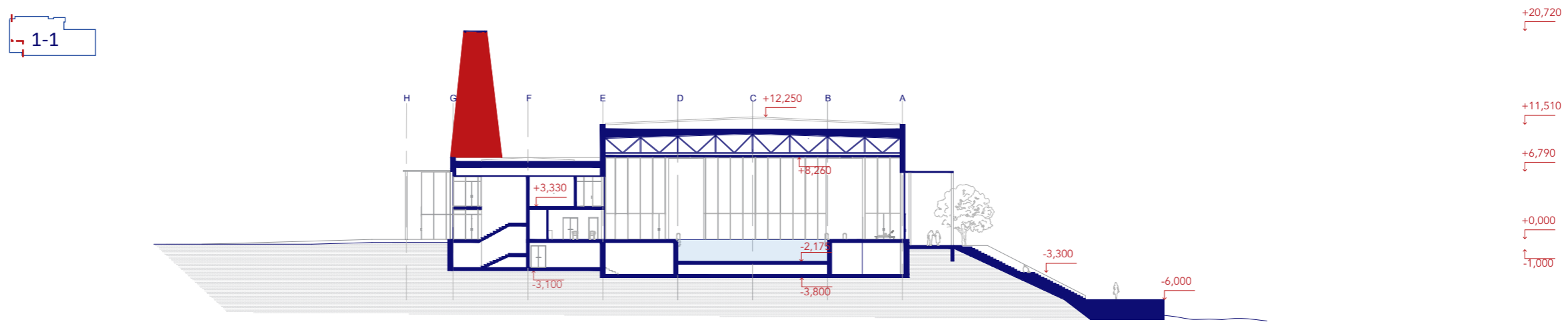

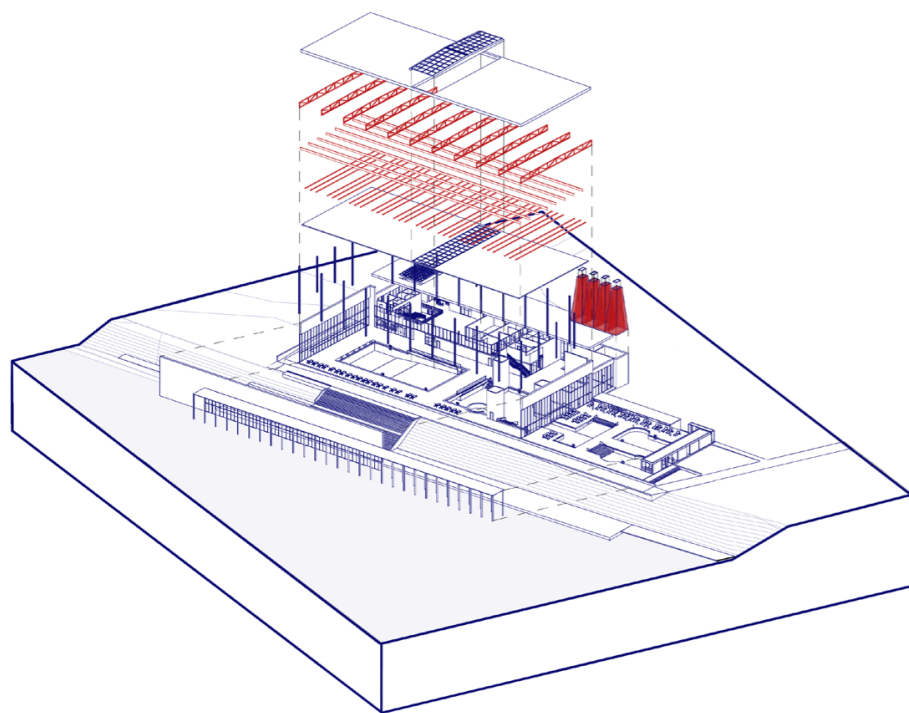

1.
  - pebble 60
  - geotextile
  - hydro isolation
  - thermal insulation EPS with a slope of 2%
  - thermal insulation EPS 200 mm
  - vapor barrier
  - profiled Sheet Roofing with thermal insulation 80 mm
  - steel truss construction

2.
  - fiber cement panels 20 mm
  - facade mounting system
  - vapor barrier
  - thermo Insulation 200
  - hydro isolation
  - concrete shell 230
  - waterproof plaster
  - reinforced concrete slab 250 mm
  - thermal insulation 150 mm
  - concrete coating

3.
  - fiber cement panels 13 mm
  - facade mounting system
  - vertical profile 40 mm
  - vapor barrier
  - Insulation 180 mm
  - hydro isolation
  - sheating

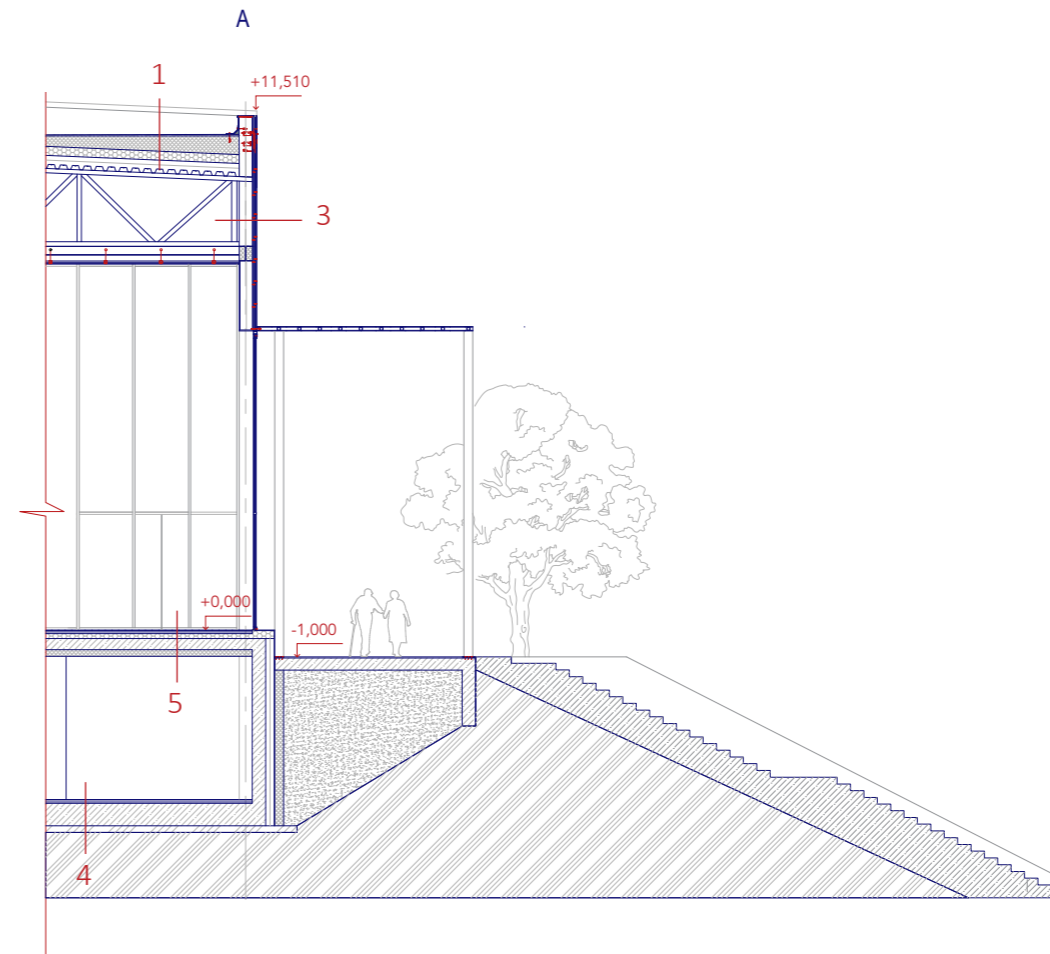

4.
  - concrete flooring 5 mm
  - step insulation 30 mm
  - separation layer
  - concrete slab 500 mm
  - hydro isolation
  - base concrete 150 mm

5.
  - glued ceramic tile 15 mm
  - hydrotextile
  - distribution layer 35 mm
  - floor heating 35 mm
  - hydroisolation
  - thermal isolation 110 xps
  - reinforced concrete slab 250 mm
  - thermal insulation 150 mm
  - sheating

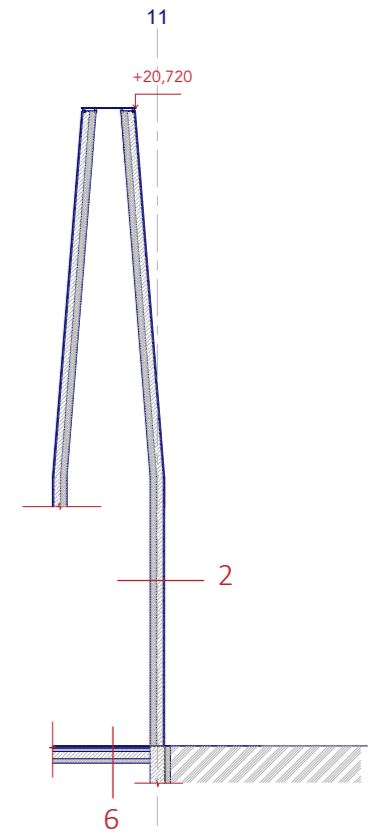

6.
  - glued ceramic tile 15 mm
  - hydrotextile
  - distribution layer 35 mm
  - floor heating 35 mm
  - hydroisolation
  - thermal isolation Xps 110 mm
  - reinforced concrete slab 250 mm
  - thermal insulation 150 mm
  - concrete coating

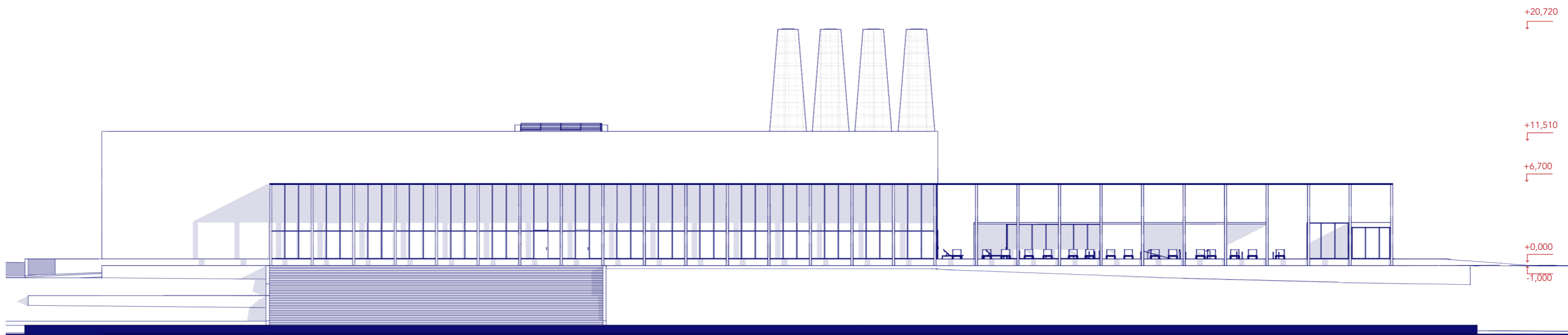
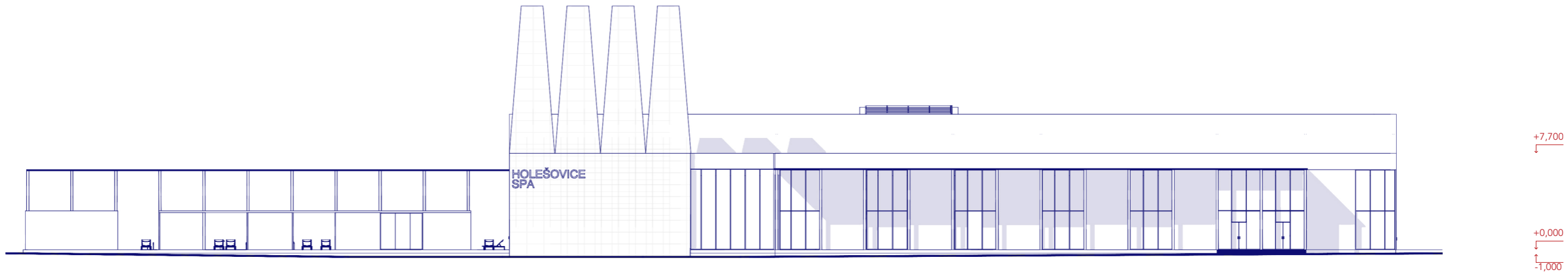





HOLEŠOVICE  
SPA



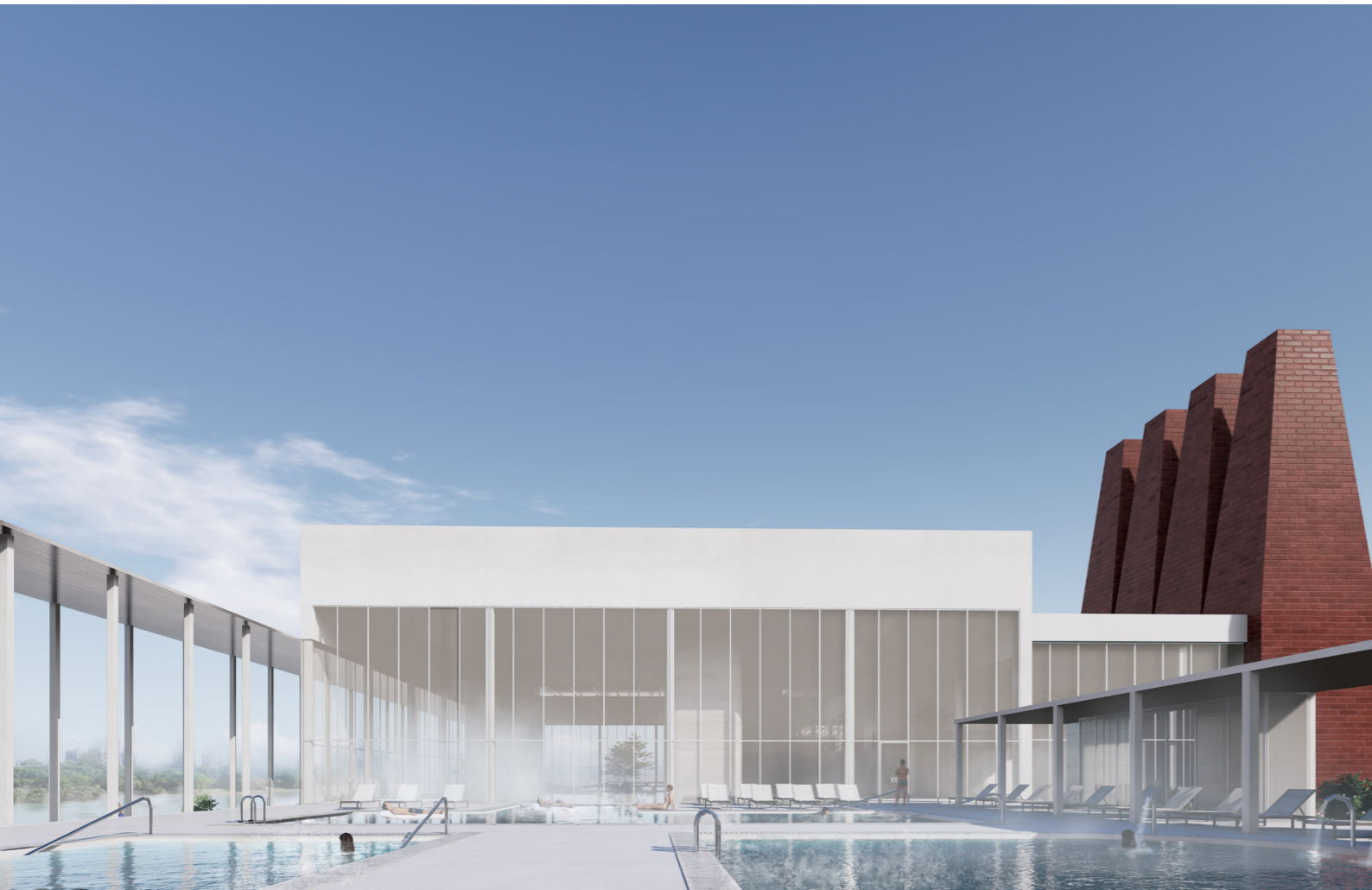









Czech Technical University in Prague, Faculty of Architecture

## DIPLOMA PROJECT APPLICATION FORM

Name and Surname: Aigerim Azirkhanova

Date of Birth: 27.05.1999

Academic Year / Semester: 2023/24 Summer semester

Department Number / Name: 15129 Department of Architectural Design III

Diploma Work / Diploma Project Leader: prof. Ing. arch. Vladimír Krátký, doc. Dipl. arch. Marques Luis

Diploma Work / Diploma Project Theme – title in English language:

Holešovice Spa Wellness Center

Signature of the Diploma Work / Diploma Project Leader:

## BIBLIOGRAPHY

1. Architects' Data (Neufert) by Ernst Neufert and Peter Neufert
2. <https://geoportalpraha.cz/en>
3. <https://app.iprpraha.cz/apl/app/atlas-prahy/>
4. <https://www.dezeen.com/>
5. <https://www.archdaily.com/>
6. <https://visuallexicon.wordpress.com/2017/10/04/function%EF%BC%9Athermal-bath-vals-peter-zumthor/>
7. <https://cs.wikipedia.org/wiki/Hole%C5%A1ovice>
8. <https://www.archdaily.com/965018/the-padel-club-healy-partners-architects/60eda5cfd05ef60164750bee-the-padel-club-healy-partners-architects-ground-floor-plan>
9. <https://dictionary.cambridge.org/dictionary/english/>
10. Chisholm, Hugh, ed. (1911). «Mineral Waters» . Encyclopædia Britannica. Vol. 18 (11th ed.). Cambridge University Press

The Student's Declaration:

I declare that I have fulfilled all the diploma work / diploma project initiation requirements stipulated by the "Study Plan" and "Study Rules" at the Faculty of Architecture, CTU in Prague.

In Prague on

12.02.2024

Signature of the Student



Czech Technical University in Prague, Faculty of Architecture

## ASSIGNMENT of the Diploma project

Master degree

Date of Birth: 27.05.1999

Academic Year / Semester: 2023/24 Summer semester

Department Number / Name: 15129 Department of Architectural Design III

Diploma Project Leader: prof. Ing. arch. Vladimír Krátký, doc. Dipl. arch. Luis Marques

### Diploma Project Theme:

See the Application Form for DP

### Assignment of the Diploma Project:

1/description of the project assignment and the expected solution objective

The project is situated in Holešovice, previously an industrial district of Prague that has witnessed a number of urban changes over the years. The spa is positioned near the historically significant marketplace, Holešovická tržnice, along the riverfront of the Vltava River, overlooking Karlín.

The purpose of the diploma project is to integrate contemporary wellness treatments with the Czech spa traditions, that are deeply rooted into the country's history, contributing both the city's identity and the well-being of its residents and visitors. In terms of urban structure, the project intends to use the site's potentials without interfering with the general character of the surrounding environment, reflecting diverse industrial past of Holešovice.

The spa center provides services on a daily basis without accommodation, such as a day or half-day retreats. The building will include outdoor and indoor swimming pools, hydrotherapy areas such as saunas, steam rooms, massage and treatments rooms, changing rooms and lockers, a cafe, lounging areas, administration offices, as well as outdoor recreational spaces.

2/description of the final result, outputs and elaboration scales

Drawing of wider relations 1:10 0000-1:25 1000  
Design situation, wider urban plan 1:500-1:1000  
Plans, sections and views 1:100-1:500  
Details (structures, facades) 1:25-1:50  
Interior and exterior visualizations

Accompanying administration in the usual breakdown and scope

All parts of the diploma project will be submitted in accordance with the decree - i.e. a portfolio in two copies, a CD with the project, the diploma student's declaration, the assignment, A1 sheets for the exhibition of diploma theses. Scales of drawings and models will be specified with the diploma project leader during the work.

3/list of further agreed-upon parts of the project (model)

Physical model of the part 1:100-1:500

To this list further attachments can be added according if necessary.

Date and Signature of the Student:

12. 02. 2024 

Date and Signature of the Diploma Project Leader:



Date and Signature of the Dean of FA CTU:



