

This is the author's accepted version of an article

PCB Sensors in Fluxgate Magnetometer with Controlled Excitation

that has been published in

Sensors and Actuators. 2009, 151(2), 141-144. ISSN 0924-4247.

Changes were made to this version by the publisher prior to publication.

The final version of record is available at:

<https://doi.org/10.1016%2Fj.sna.2009.02.002>

All rights of the publisher are reserved.

PCB sensors in fluxgate magnetometer with controlled excitation

Michal Janošek^a, Pavel Ripka^a

^aCzech Technical University in Prague, Faculty of Electrical Engineering, Dept. of Measurement, Technická 2, 166 27 PRAGUE, Czech Republic

Abstract

A miniature fluxgate sensor with amorphous race-track core manufactured with printed circuit board (PCB) technology is presented in this paper. The number of PCB layers was increased to five; this allowed for increasing the number of turns of pickup/compensating winding (68), resulting in the compensation current in the feedback loop below 15 mA for a 50 μ T measured field. The sensor was characterized using pulse excitation (10 kHz, 10% duty); the maximum sensitivity was found to be 615 V/T for 650 mA p-p excitation current with nonlinearity below 0.5 % of full scale. In order to improve the long-term and temperature stability of the sensor, a closed-loop regulation of the excitation current amplitude was designed. A three-axial portable magnetometer using gated integrators and pulse excitation was constructed with these sensors. Feedback-loop operation allowed suppressing the nonlinearity below 100 ppm of $\pm 50 \mu$ T full-scale, and the sensitivity increased to 120,000 V/T. Long-term stability was found to be 1 nT in nine-hour period, and the temperature coefficient of sensitivity decreased to 50 ppm, which was a direct result of controlling the excitation current.

1. Introduction

PCB technology in fluxgate sensors, as introduced in [1], brings the following benefits: stability of the sensor's parameters (as there are no wound or moving parts), low dimensional demands, and ease of mass-production. The progress in PCB fluxgate sensors clearly shows that the limitation in their parameters is the low number of turns of the coils created by PCB technology. For an excitation coil, this problem can be solved using a pulse excitation current, which allows for effectively decreasing power dissipation while still maintaining sufficient saturation of the core. As for the pick-up coil, the coil constant determines not only the sensitivity of the sensor, but it also determines - when used as a feedback coil - the power dissipation in compensating mode, which practically limits its usability.

2. Development of PCB fluxgate sensor 'IIIA'

In previous work, as done by Kubík et al. [2],[3], miniature sensors with a race-track core of the amorphous material Vitrovac 6025X were made using a three-layer PCB technology, with excitation and pick-up coils formed by copper track connected by electroplated through-hole vias. Compared to micro-sized designs with planar coils [4], this sensor allowed us to use much lower excitation frequencies. The number of turns of the pick-up coils was low, which limited their performance.

The new sensor IIIA was designed to use 5 PCB layers; the pickup coil is formed by the copper tracks on the top and bottom layers (Fig. 1 -1, 4), and the excitation coil consists of tracks on two middle layers (Fig. 1- 2, 3). Technologically, the inner part was laminated in the first phase; in the second step this sub-PCB was laminated between the top and bottom layers. The etched race-track core of 25 μ m thick material is laminated in a machined bobbin in the middle. The dimensions of the sensor are 33.5 \times 15.6 \times 0.9 mm.

When compared to the previous sensor type IIA with a similar design but only three PCB layers [5], the number of turns of pickup winding was increased from 20 to 68; thus the compensating current for the 50 μT measured field decreased from 46 mA to 14.5 mA. The pickup winding resistance increased to 4.9 Ω due to the increased number of electroplated holes; this determines power loss in the winding (1 mW for 50 μT). Both sensors are shown in Fig. 2.

3. Pulse excitation unit with amplitude stabilization

Pulse excitation is used because of lower power consumption. It has been observed that the offset and sensitivity parameters of sensor IIIA depend on the amplitude stability of the excitation current. This could be caused by asymmetry of the sensor (varying thickness of the amorphous layer, misalignment of the pickup or excitation coil respectively), and by the possible presence of even harmonics in the excitation current (due to unmatched bridge resistances). A feedback circuit was designed in order to stabilize the amplitude of the current peaks caused by the temperature drift of the resistance of the excitation winding or of the MOSFET switches.

A block diagram of the excitation unit is shown in Fig. 3. Driving pulses for the full H-bridge are provided by decoding three PWM outputs of the PIC16F737 microcontroller. The excitation current is sampled with a peak detector and a PI-regulator drives the reference setting of the DC/DC converter, whose output is the bridge voltage V_{br} . The desired reference setting is provided by a D/A converter of the microcontroller.

The sensor's sensitivity, linearity and offset have been measured with a lock-in amplifier SR-830 referenced to the second harmonic of excitation current. The results, as shown in Fig. 4, indicate the largest sensitivity for 650 mA p-p excitation current. However, the sensor's offset increases only marginally with the excitation current (4 nT change for 500 mA excitation current change, not shown in Fig. 4).

4. Feedback-loop operation in a magnetometer

A battery powered three-axis magnetometer unit was constructed, with a triaxial sensor holder, which was connected to the body of the magnetometer directly or with a cable. A pulse excitation unit with controlled and amplitude-stabilized excitation current was used according to Fig. 3, and the output signal was processed with the use of gated integrators [5]. All of the following measurements were done with an excitation current of 450 mA p-p, which was found to be the best compromise, with a frequency of 10 kHz and a 10% duty cycle.

4.1 Sensitivity, linearity parameters

Sensitivity was measured using a simple vectorial calibration in Helmholtz coils; later a scalar calibration (implemented after Olsen et al., [6]) was performed in a magnetically quiet location and referenced to the reading of an Overhauser magnetometer. The RMS error of the calibration was 9 nT. Linearity of the magnetometer was determined by averaging multiple runs of sensitivity measurements in Helmholtz coils, covering the whole full scale of $\pm 50 \mu\text{T}$. Results are summarized in Table 1. There is an indication of scale error of the vectorial calibration, as the ratio of the sensitivities is the same for both methods. When the sensor triplet was connected to the magnetometer's body, sensitivities changed by +0.8%, +1.1 % and +1.4 % for the X, Y and Z axes respectively. This is believed to be an effect of compensation flux leakage due to the magnetometer body. Also, the offset of the Z-axis increased to 650 nT (influence of built-in accumulators and magnetometer electronics).

Axis	X	Y	Z
Sensitivity - vector cal.[V/T]	106757	104413	106562
Sensitivity - scalar cal. [V/T]	119952	117107	119491
Offset [nT] - from scalar cal.	-1048	-257	68
Axes non-orthogonalities ["]	1345.4	485.2	4936.5
Nonlinearity [ppm of FS]	65	60	93

Tab. 1 - Overview of magnetometer's sensitivities and nonlinearities

4.2 Offset stability in the feedback loop

Offset stability was measured using six-layer **Permalloy** cylindrical shielding, with electronics kept in a temperature-stable place; the sensor temperature varied by ± 1 °C. The influence of the excitation amplitude on the offset stability was evaluated: larger excitation currents exhibited larger offset drift due to the sensor's self-heating. As the best result, an excitation current of 450 mA was chosen for operation in the magnetometer. Long-term measurements resulted in an offset stability of 1 nT in nine hours (Fig. 5), with approx. 1 nT p-p short-time change (ultra-low-frequency noise), which is superior to the 3.7 nT stability of sensor IIA previously achieved in [5]. When the stabilization circuitry was disabled, the offset stability worsened to 4 nT in nine hours and the ultralow-frequency noise increased to 2 nT p-p.

4.3 Temperature stability

Temperature stability was measured separately in order to evaluate the influence of the sensor and electronics. The sensor (or the magnetometer electronics) was temperature cycled within 70 °C change, and the stability was then determined in the working range of 10-45 °C.

Influence of the sensor		Influence of the electronics	
Sensitivity Tc	Offset Tc	Sensitivity Tc	Offset Tc
-29 ppm/K	+2.2 nT/K	-20 ppm/K	-1 nT/K
Combined		-49 ppm	+1.2 nT/K

Tab. 2 – Magnetometer's temperature stability

The stabilizing circuitry was also disabled to determine the change in parameters: the influence of the electronics was basically the same, but the sensor influence to sensitivity drift worsened to -145 ppm; this was 5x higher than the value measured with the stabilized excitation amplitude.

4.4 Noise parameters

Noise parameters have been measured again in the Permalloy shielding, using an Agilent 35670A spectrum analyzer, applying a Hanning window, 50x averaging, and 90% overlap. Results are typically below 20 pT/ $\sqrt{\text{Hz}}$ @ 1 Hz and 140 pT_{rms} in 10 Hz bandwidth (0.1÷10 Hz) – see Fig. 6.

5. Conclusion

A PCB fluxgate sensor with racetrack core **and five PCB layers** was manufactured using dual lamination technology. Its sensitivity was found to be 650 V/T for a 650 mA p-p excitation current (10 kHz, 10% duty cycle). Magnetometer operation in a feedback loop resulted in sensitivities of approx. 120 000 V/T, nonlinearity below 100 ppm, and noise typically below 140 pT_{RMS} in 10 Hz bandwidth. Stabilization of the excitation current resulted in long-term

offset stability of 1 nT in nine hours. The temperature dependence of sensitivity due to the temperature of the sensor was suppressed down to 50 ppm/K. The designed circuit for excitation amplitude stabilization has proven to be feasible, and it will be the subject of further improvements. When compared to the results achieved with previous sensor design, the nonlinearities in feedback-mode operation remained at the same level, below 100 ppm, while improving the long-term offset stability more than 3.5x and decreasing the current needed in the feedback coil more than 3x (down to 14.5 mA for 50 μ T).

References:

[1] DEZUARI, O. – BELLOY, E. – GILBERT, S.E. – GIJS, M.A.M: New hybrid technology for planar fluxgate sensor fabrication. IEEE Trans. Magn. 35 (4) 2111-7, 1999, pp. 349-355

[2] KUBIK, J. - PAVEL, L. – RIPKA, P.: PCB racetrack fluxgate sensor with improved temperature stability. Sens. Act. A, Vol. 130-131, 2006, pp.184-188

[3] TIPEK, A.; O'DONNELL, T.; RIPKA, P.; KUBIK, J.: Excitation and temperature stability of PCB fluxgate sensor. Sensors Journal, IEEE Volume 5, Issue 6, Dec. 2005, pp. 1264 – 1269

[4] RIPKA, P. – KAWAHITO,S. – CHOI, S.O. – TIPEK,A: Micro-fluxgate sensor with closed core, Sens. Act. A, Vol. 91, 2001, pp. 65–69.

[5] KUBIK, J. – JANOSEK, M. – RIPKA, P.: Low-power fluxgate sensor signal processing using gated differential integrator, Sensor Letters Vol. 5, pp. 149–152, 2007

[6] OLSEN, N. - TØFFNER-CLAUSEN, L. - RISBO, T. - BRAUER,T. - MERAYO, J. - PRIMDAHL, F. - SABAKA, T: In-Flight Calibration Methods used for the Ørsted Mission, Ground and In-Flight Space Magnetometer Calibration Techniques, ESA SP-490, 2001

Michal Janošek, born in Varnsdorf, Czech Republic, in 1980. Graduated from the Faculty of Electrical Engineering, Czech Technical University in Prague in 2007 (Dept. of Measurement - Measurement and Instrumentation) and is now pursuing the PhD degree at the same department. His main research activity is the application of magnetic sensors in sensing and detection of ferromagnetic objects and further development in PCB fluxgate sensors.

Pavel Ripka (Ing, Prof) was born in Praha in 1959. He received an Engineering degree in 1984, a CSc (equivalent to PhD) in 1989, Associate Prof. in 1996 and finally Prof. in 2002. He works at the Department of Measurement, Faculty of Electrical Engineering, Czech Technical University as a professor, lecturing in Measurements, Engineering Magnetism and Sensors. His main research interests are Magnetic Measurements and Magnetic Sensors, especially fluxgate. He is a co-author of 3 books and > 50 journal papers.

Fig 1 - Sensor IIIA construction – sensor core with its bobbin (2), layers forming excitation coil (1, 3) and pick-up coil layers (4, 5)

Fig 2 – Sensor IIIA (left) and the old design IIA (right) for comparison

Fig 3 - Block diagram of the excitation unit

Fig 4 - Sensor parameters – measured in open load with 2nd harmonic detection using SR 830 lock-in amplifier

Fig 5 - 9-hours offset stability achieved with controlled excitation in the magnetometer

Fig 6 – Noise spectrum of the tri-axial magnetometer. Noise of the electronics only (when the excitation was disabled) is shown for the reference.

Fig. 1 - Sensor IIIA construction.
[Click here to download high resolution image](#)

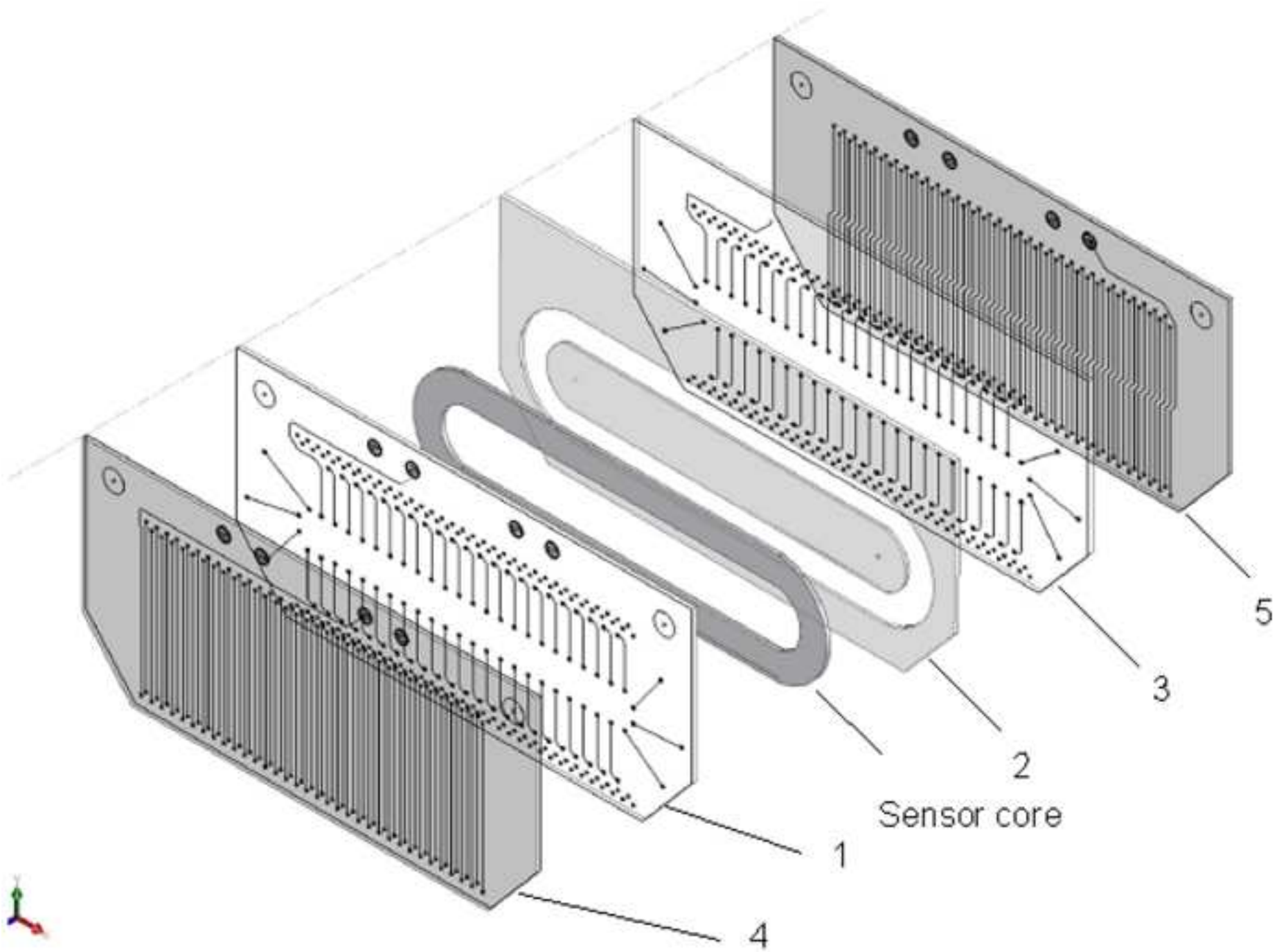
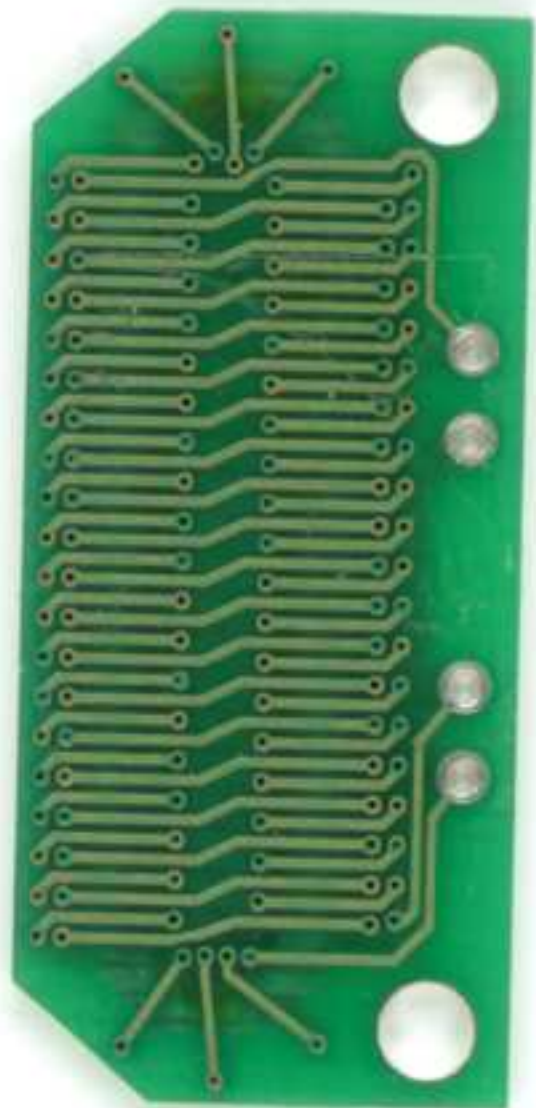

Fig. 2 - Sensor IIIA, old design IIA shown for comparison
[Click here to download high resolution image](#)



IIIA



IIA

Fig. 3 - Block diagram of controlled excitation unit
[Click here to download high resolution image](#)

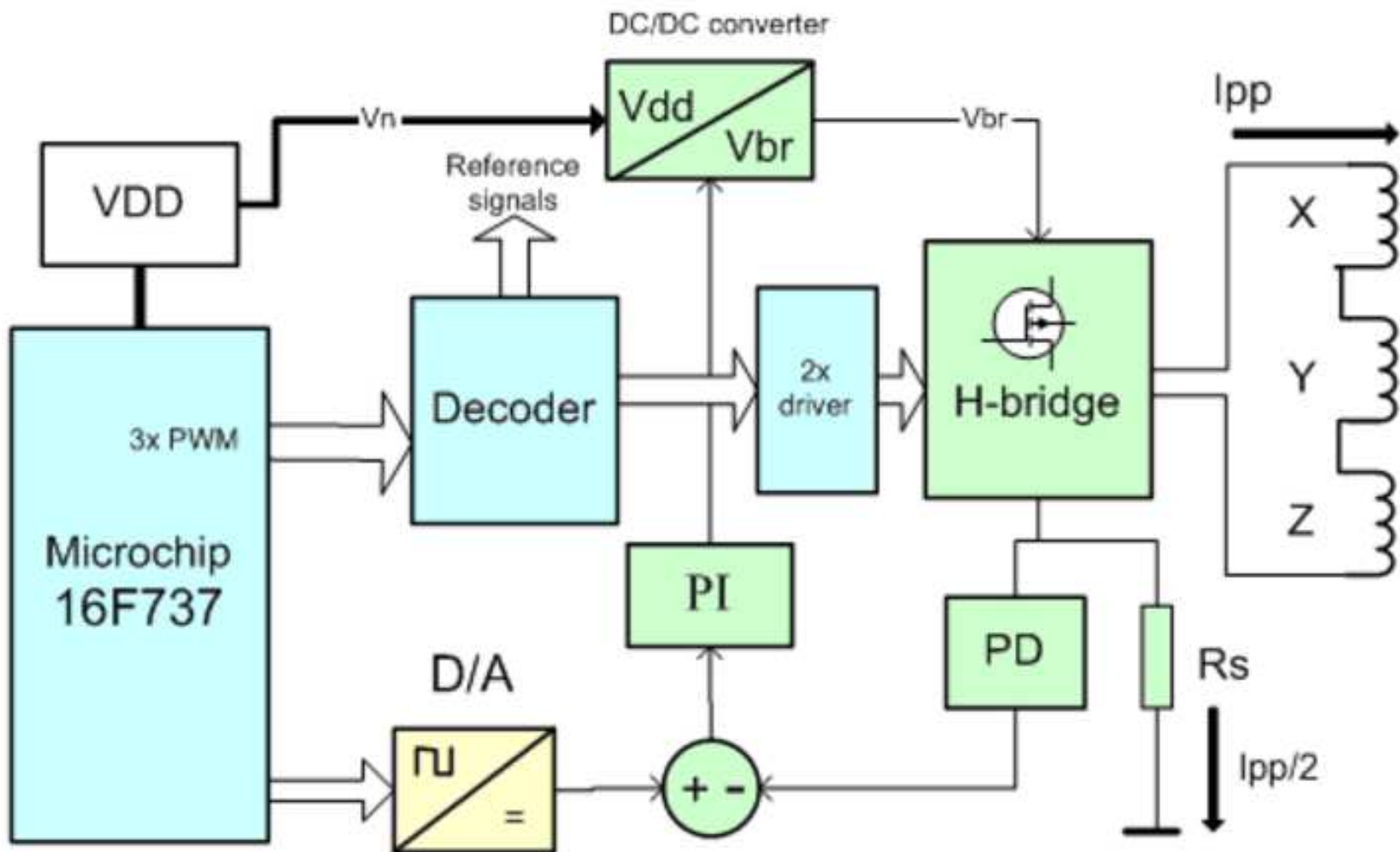

Fig. 4 - Sensor parameters - open loop
[Click here to download high resolution image](#)

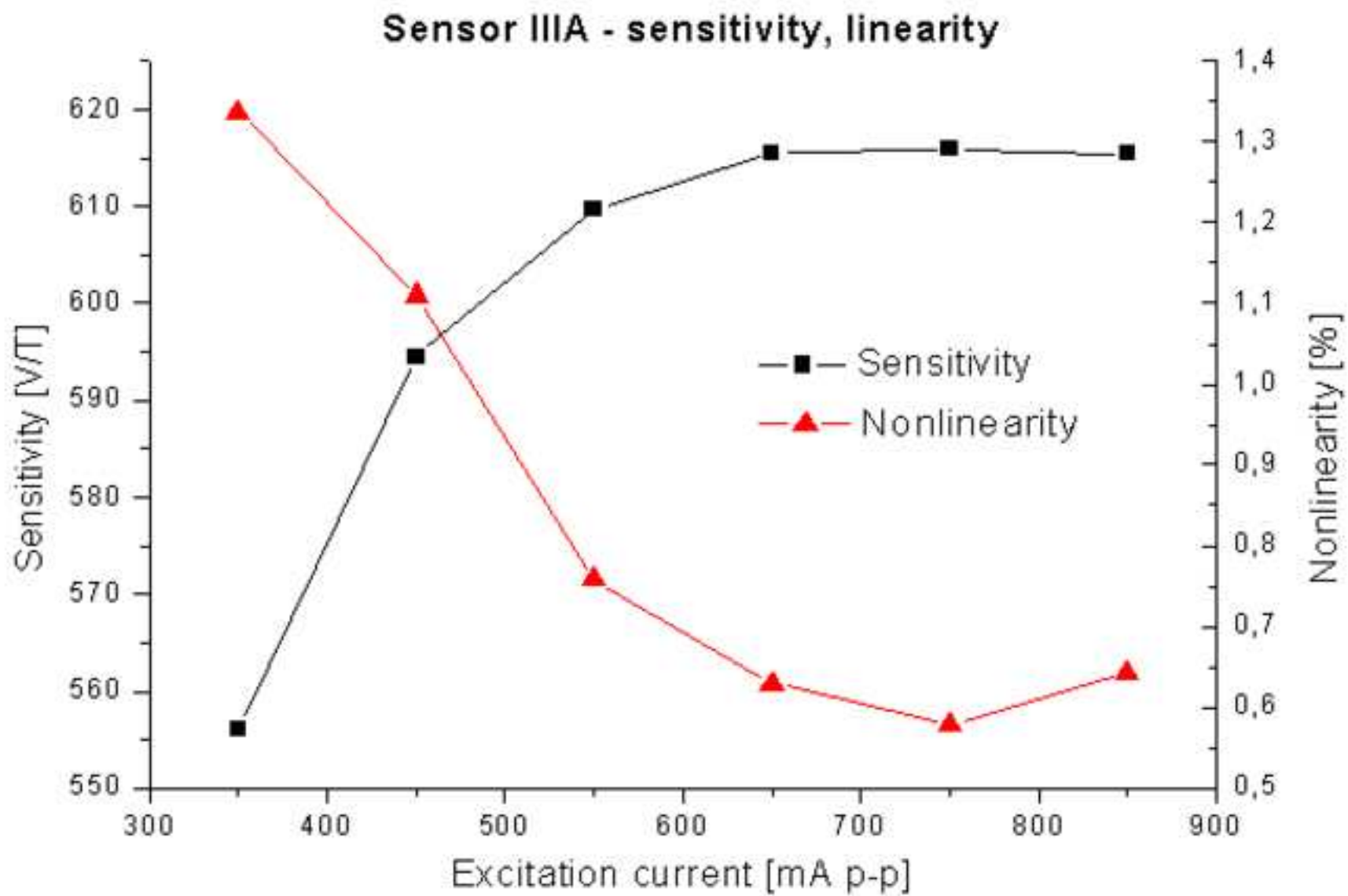

Fig. 5 - 9-hours offset stability
[Click here to download high resolution image](#)

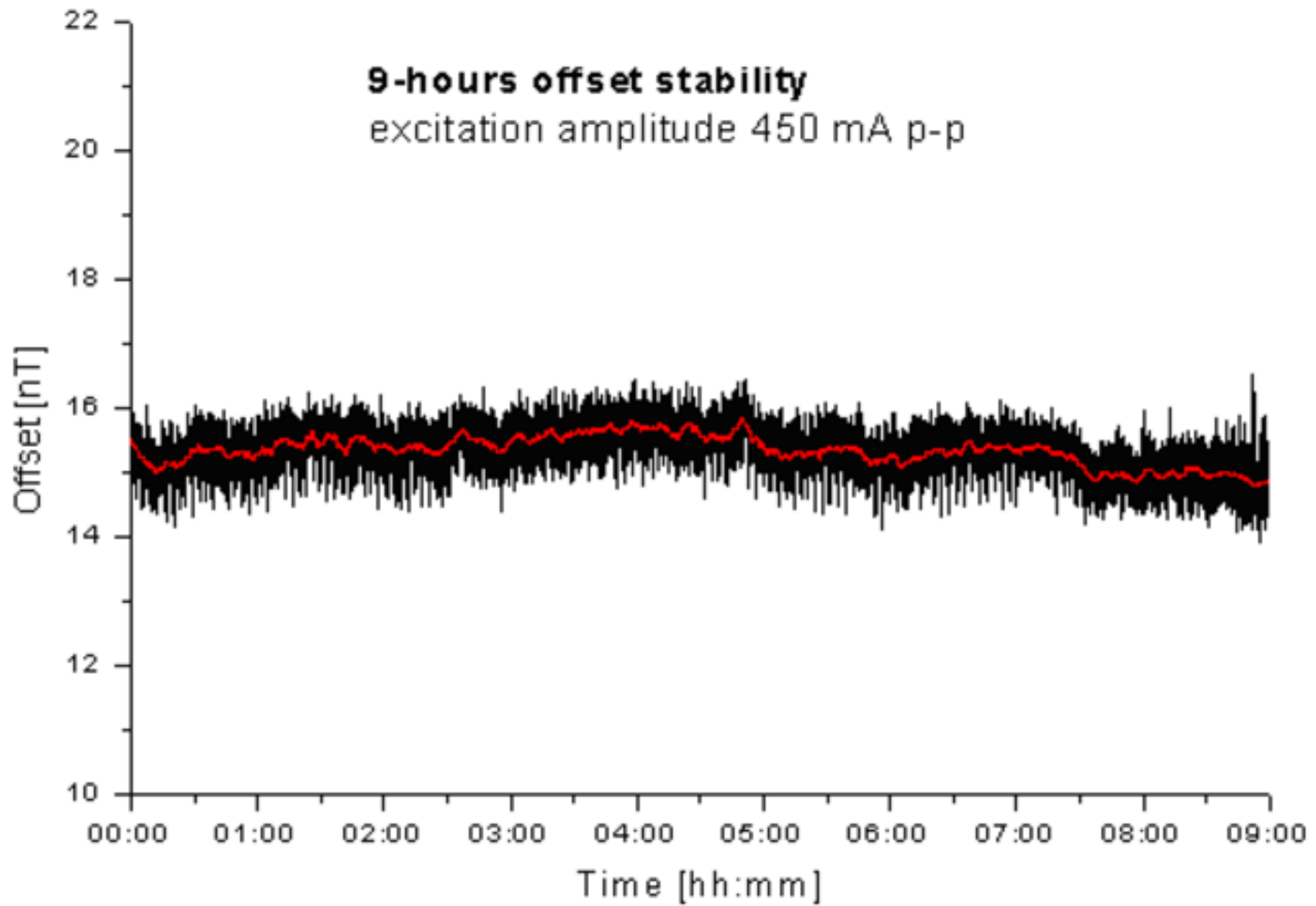

Fig. 6 - Noise spectrum of the magnetometer
[Click here to download high resolution image](#)

Magnetometer noise - X,Y,Z

