

# **DISSERTATION THESIS**

Assessment of Influences on the Early Age Concrete  
Strength Development

Posouzení vlivů na vývoj pevnosti betonu raného stáří

## **STUDY PROGRAM**

Civil Engineering

## **BRANCH OF STUDY**

Structural and Transportation Engineering

## **SUPERVISOR**

prof. Ing. Jan L. Vítek, CSc., FEng.

KASAL

PAVEL

**2024**

Kasal, Pavel. *Assessment of Influences on the Early-age Concrete Strength Development*. Prague: CTU 2024. Dissertation thesis. Czech Technical University in Prague, Faculty of Civil Engineering.



**FACULTY OF CIVIL  
ENGINEERING  
CTU IN PRAGUE**

## **Declaration**

I hereby confirm that I have worked on my dissertation thesis on my own, just with the advisement of my supervisor prof. Ing. Jan L. Vítek, CSc., Feng.

I declare all the references I have used to write this thesis and stated in the bibliography. I am understood with the usage of this thesis according to the § 60 law no. 121/2000 Sb. (Copyright Act)

January 19, 2024, Prague

Signature:

## Acknowledgements

I would like to thank my supervisor, **prof. Ing. Jan L. Víték, CSc., Feng.** for professional guidance of the thesis and many practical recommendations.

I want to thank my colleague **Dipl.-Ing. Werner Wenighofer** for many interesting discussions and support. Many thanks to **Ing. Vladimír Vacek** for initiations from practice. Special thanks to **Ing. Robert Coufal, Ph.D.** and his team from concrete supplier TBG Metrostav, who allowed me to perform experiments in their facilities. Last but not least I want to thank my wonderful wife for her support.

<https://doi.org/10.14311/dis.fsv.2024.002>

## **Abstract**

The thesis deals with the influences of concrete mix design changes and common deviations during concrete production on the regression relationship of the maturity method, which represents the compressive strength development of the specific concrete mix design and is a basis for nondestructive monitoring of early-age compressive strength. The main aim is to get more insights into the behaviour of regression relationships, which the standard calls the calibration curve, in response to changes in the concrete mix design or deviation during concrete production. It should allow easier usage of the maturity method, which is used in practice more often. The research was divided into several phases. The tests started in the laboratory environment, which provided more precise results as a preparation for tests in practice. Then, the investigation of different concrete mix design changes and their influences continued on the concrete plant, which already offers valid practical results. One of the last phases took place directly on the construction site and investigated the deviations in practice during the actual concrete pouring within two seasons. Those results provide transparent information about the accuracy of the maturity method applied in practice.

## **Keywords**

Early Age Concrete, Compressive Strength, Maturity Method, Calibration Curve, Strength-Maturity Relationship

## **Abstrakt**

Tato práce se zabývá vlivem změn v receptuře betonu a běžných odchylek při výrobě na regresní vztah metody zralosti, který popisuje vývoj pevnosti betonu v tlaku dané receptury a je základem pro nedestruktivní měření pevnosti betonu raného stáří. Hlavním cílem práce je získání poznatků o chování regresního vztahu, který je normou nazýván jako kalibrační křivka, na změny receptury či odchylky ve výrobě betonové směsi. To má za cíl usnadnit použití metody zralosti, která je v současnosti stále více využívána v praxi. Výzkum byl rozdělen do několika částí. Zkoušky začaly nejdříve v laboratoři a poskytly přesnější výsledky pro naplánování navazujících zkoušek v prostředí praxe. Dále pokračovalo zkoumání vlivů různých úprav receptur na kalibrační křivku přímo na betonárně, což poskytuje velmi užitečné výsledky pro praxi. Odchylky v dávkách betonové směsi a jejich vlivy na přesnost metody byly zkoušeny přímo na stavbě během betonáží v rámci dvou ročních období. Tyto výsledky poskytují přehlednou informaci o přesnosti metody zralosti při použití v praxi.

## **Klíčová slova**

Beton raného stáří, Pevnost v tlaku betonu, Metoda zralosti, Kalibrační křivka, Vztah zralosti a pevnosti v tlaku

# Table of contents

<b>1</b>	<b>Introduction .....</b>	<b>8</b>
1.1	Fundamental terms.....	9
1.2	Aim of the thesis.....	10
1.3	Structure of the thesis.....	11
<b>2</b>	<b>Cement Hydration .....</b>	<b>12</b>
2.1	Cement.....	13
2.2	Clinker Composition.....	15
2.3	Hydration of Cement.....	15
2.4	Determination of Heat of Hydration.....	19
<b>3</b>	<b>Concrete and Compressive Strength .....</b>	<b>23</b>
3.1	Concrete Mix Design.....	23
3.2	Curing.....	28
<b>4</b>	<b>Compressive Strength Determination.....</b>	<b>36</b>
4.1	Destructive testing .....	36
4.2	Non-destructive testing.....	41
<b>5</b>	<b>Maturity Method.....</b>	<b>45</b>
5.1	Common Maturity Methods.....	47
5.2	Calibration.....	51
5.3	Strength-Maturity Relationship .....	54
5.4	Validation .....	54
5.5	Measuring in Practice.....	55
5.6	Comparison with rebound hammer .....	56
5.7	Results of Recent Research.....	56
<b>6</b>	<b>Experimental Analysis .....</b>	<b>59</b>
6.1	Procedure .....	59
6.2	Procedure of Analysis .....	59
6.3	Methodology .....	61
6.4	Extent of research .....	61
<b>7</b>	<b>Isothermal Calorimetry of Cement.....</b>	<b>62</b>
7.1	Results .....	62
7.2	Summary .....	66
<b>8</b>	<b>Cement Mortar Tests in Laboratory .....</b>	<b>67</b>
8.1	Methodology .....	67
8.2	Procedure .....	70
8.3	Results.....	72
8.4	Summary .....	83

<b>9</b>	<b>Concrete calibrations</b> .....	<b>84</b>
9.1	Methodology .....	84
9.2	Procedure .....	86
9.3	Results .....	87
9.4	Summary .....	100
<b>10</b>	<b>Concrete validation</b> .....	<b>101</b>
10.1	Procedure .....	101
10.2	Results .....	102
10.3	Summary .....	105
<b>11</b>	<b>Influence of added water</b> .....	<b>106</b>
11.1	Procedure .....	107
11.2	Results .....	108
11.3	Summary .....	110
<b>12</b>	<b>C-value determination</b> .....	<b>111</b>
12.1	Procedure .....	113
12.2	Results .....	114
12.3	Summary .....	114
<b>13</b>	<b>Conclusion</b> .....	<b>116</b>
13.1	Effects of specific concrete mix design changes.....	116
13.2	Deviations in practice .....	119
13.3	Limitations.....	119
13.4	Recommendation for further research .....	120
	<b>Bibliography</b> .....	<b>121</b>
	<b>List of figures</b> .....	<b>126</b>
	<b>List of tables</b> .....	<b>129</b>
	<b>Appendixes</b> .....	<b>130</b>
	Appendix 1 - Rebound Hammer .....	131



# 1 Introduction

Concrete is the most used building material in the construction industry. It is used frequently in infrastructure projects, as well as in residential projects. The widespread use of concrete is caused mainly by its universality of usage, mechanical properties, durability, perfect synergy with reinforcement, and low costs. [1; 2]

Cement is one of the essential constituents of concrete due to its chemical reaction with water – hydration of cement. If cement is mixed with water, it results in cement paste, which sets and hardens. During the setting process, the cement paste loses workability and ductility. Then, during the hardening process, the compressive strength increases. Concrete consists of aggregates connected by hardened cement paste. [1]

The compressive strength of concrete is one of the critical properties of concrete at an early age and later age. Knowing the current compressive strength value at an early age helps determine a suitable time for removing the formwork, moving the climbing formwork to the next step, loading the structure, applying prestressing forces or finishing curing operations. It allows for shortening of the construction site's cycle time, leading to the optimised construction process in terms of time, costs and safety. Some destructive and non-destructive tests allow for determining compressive strength at an early age. [3; 4]

One of the non-destructive methods described in this thesis in more detail is the so-called maturity method. This method is used all over the world using different maturity functions. Implementation of this method into measuring devices is quite simple.

Usage of the method still increases due to advancing digitalisation in the construction industry and time pressure in the construction process with the same quality requirements. Expanding the number of commercial maturity systems available on the market, especially in the last five years, also contributes to increasing the usage of the maturity method. Last but not least, more frequent use of cement types with reduced clinker content (e.g. Portland composite cement CEM II/B) and ambitious plans for decarbonising the cement industry, which proposed wider use of CEM II/C and CEM VI create new opportunities for maturity methods because of slower compressive strength development. [5; 6]

The most crucial step before the beginning of the measuring is a calibration of the particular concrete mix design which will be used in the project. Calibration determines the calibration curve experimentally for a specific concrete mix design. The calibration curve shows the relationship between maturity and compressive strength. It means that once the calibration curve is developed, the compressive strength development



of the calibrated concrete mix can be calculated based on the actual temperature development of the concrete. As soon as the concrete mix design is changed, a new calibration curve should be performed. [7; 8]

The process of calibration costs time, money and effort of lab technicians. Construction companies and concrete suppliers want more insights into the influences on the calibration curve, allowing them to simplify the process and reduce their effort during calibration. Recent research shows the first results, how a change in a concrete mix composition can influence the calibration curve. However, a detailed and up-to-date analysis showing the effect of various changes in concrete mix composition on the calibration curve (compressive strength development) is still missing. Moreover, most investigations were performed in the laboratory and not in practice, where the situation is different, and many deviations can occur. [9; 10; 11]

Based on the potential of the maturity method and the need for more insights in the construction industry, this thesis will provide **an overview of frequent changes in a concrete mix composition and their impact on the calibration curve** = compressive strength development. This overview can help to reduce the effort during the calibration process, unsuccessful tries and, in the end, the number of concrete calibrations. Additionally, the thesis will give **information on possible deviations in practice** (at the batching plant and construction site). Those deviations are essential to consider while implementing the method in the construction project.

## 1.1 Fundamental terms

The following terms are often used in the thesis:

**Early age concrete** – Early age period starts when the concrete is poured and compacted, but its end is not strictly defined. It depends on the investigated property of concrete. If the compressive strength is monitored, early-age concrete can be considered up to 7 days from pouring or up to 70% – 80% of 28-day compressive strength. [12]

**Compressive strength** – Compressive strength is the fundamental property of concrete. Value gives a rough indication of "concrete quality". Typical compressive strength development is quick at an early age and slower at a later age. However, the development depends on the concrete mix composition and concrete temperature. The compressive strength of concrete is usually destructively tested on standard cubes or cylinders in construction practice. Unit is [MPa] alternatively [Psi]. [1; 12]

**Maturity method** – The non-destructive method which allows for determining the compressive strength of the concrete in the structure based on the calibration curve and temperature development. The method enables comparing the compressive strength development of different calibrated concrete mixes or the strength development of a single concrete mix maturing at various temperatures. The maturity method is described in more detail below (chapter 5). [7; 8]



**Maturity** – Maturity [ $^{\circ}\text{Ch}$ ] is a product of time and temperature. The value of maturity can be calculated using equations of different maturity methods described in chapter 5.1 [7; 8]

**Calibration curve or line** – The relationship between maturity and strength development is determined based on testing samples of different ages. [4; 7]

## 1.2 Aim of the thesis

The thesis aims to clarify following topics and answer the particular questions mentioned below:

- **Verification of the usage of the maturity method in practise:** Does maturity method provide reliable result also on the construction site with ready mix concrete? What are the deviations of early age strength development of one particular concrete mix design supplied regularly in a typical construction project?
- **Specification of the most important parameters influencing the compressive strength development in early age:** In particular, what is the effect of specific concrete mix design changes on compressive strength development (calibration curve)?
  - Representative concrete mix design changes:
    - Cement:
      - Cement types
      - Cement amount
      - Cement source
    - Water
      - Water/cement ratio
    - Aggregates
      - Different types of sand
      - Maximum grain size
    - Admixtures
      - Superplasticizer
      - Accelerator
    - Additions or cement replacement
      - Fly ash
      - Limestone

The list of selected concrete mix design changes above presents only a rough idea. More details are shared in the practical part (chapter 6). The author's concept is to adapt the concrete mix design in the way it is done in practice and not create theoretical concrete mix design (e.g. very high cement content + very high dosage of water).

- **Evaluation of the effect of deviations in concrete composition on the compressive strength development at early age:** Which concrete mix design changes (from the list above) are not significant and do not require recalibration? Which



---

deviations may the individual components have in dosage so that recalibration does not have to be performed? Is it possible to recalculate the calibration curve based on a change in concrete mix design instead of the need for recalibration?

- **Recommendation for application of the maturity method and specification of the safety factors:** Can the safety factor calculated according to NEN 5970 cover those deviations?

### 1.3 Structure of the thesis

The dissertation thesis is divided into 13 chapters. **Chapters 2 to 5 provide the theoretical background**, complemented by the author's experiences or his own measurements. **Chapters 6 to 12 are purely focused on the execution of the experimental part**, results and gained findings. Each chapter is finished with a summary showing preferably the new knowledge. The general conclusions are summarised in chapter 13.



## 2 Cement Hydration

This chapter covers theoretical basics related to concrete mix composition and cement hydration, which are necessary to mention for a better understanding of consequent chapters and especially the practical part of the thesis. For a more straightforward explanation of the hydration process, one of the results of isothermal calorimetry tests of cement performed by the author is used.

Before a more detailed description of the hydration process, several essential pieces of information about concrete composition are introduced. Concrete consists of aggregates covered and connected with cement paste. Fresh concrete consists of the following materials: [1]

- aggregates
- cement
- water
- admixtures
- additions.

As mentioned in the introduction, cement plays a crucial role in concrete because it sets and hardens after mixing with water. The cement paste (cement + water) surrounds coarse and fine aggregates in a fresh concrete mix. Water allows cement hydration reaction and workability of fresh concrete. The mixed cement paste first sets and then hardens due to cement hydration. The setting process of the cement paste is characteristic of loss of workability and malleability. Then, during the hardening process, the compressive strength increases. In the end, the cement hydration reaction results in "an artificial stone." [1; 2]

Admixtures can enhance or modify concrete properties; the most common example is a superplasticiser, which can assure suitable consistency with lower water content. Additions, powder materials, are used for cement substitution or improving specific properties of concrete. [1; 2]

The usual concrete mix contains approximately 75% of aggregates, 15% of cement, 7% of water, and the remaining 3% weight could be filled by additions and admixtures. Admixtures usually fill less than one per cent of fresh concrete weight, and their dosage is specified to cement weight. [1]

Since concrete was introduced as the most used construction material globally (chapter 1), selected global figures regarding its production are shared. The three biggest producers, China National Building Material (approx. 112 Mm<sup>3</sup>), Cemex (approx. 47.0 Mm<sup>3</sup>), and Heidelberg Materials (approx. 46.9 Mn<sup>3</sup>), are followed by Holcim, CRH and others. The global concrete production in 2020 was approximately 10.1 billion m<sup>3</sup>. Most of the concrete was produced in China, approx. 28% of the worldwide production. [13]

## 2.1 Cement

The main ingredient of cement is the clinker, which is produced by heating a mixture of raw materials (limestone, clay, correcting and auxiliary materials) at 1450°C in a rotary kiln. The manufactured clinker is then ground with gypsum or anhydrite, which acts as a setting controller. Adding a suitable dosage of gypsum or anhydrite allows the use of cement in construction practice because it avoids a fast drop in workability when it is mixed with water. [1; 14]

During clinker production, the calcination process in the rotary kiln requires quite a high temperature and splits the material into calcium oxide and carbon dioxide (1). The whole production releases a large quantity of CO<sub>2</sub> into the atmosphere. This topic is often discussed as one of the biggest challenges concerning sustainability in the construction industry. Roughly two-thirds of the overall CO<sub>2</sub> emissions of clinker production come from limestone. The remaining one-third comes from the fuels for heating the kiln at 1450°C. By the way, the flame's temperature is roughly up to 2000°C. Other processes during cement production, such as grinding, cooling, mixing, and transport, have significantly lower CO<sub>2</sub> emissions. Cement is responsible for approximately 8% of the world's CO<sub>2</sub> emissions. [5; 15]

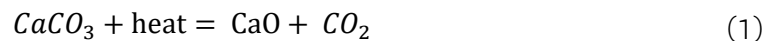

Every final cement product needs to comply with cement standards. The detailed specification of cement types is stated in EN 197-1 and recently published standard EN 197-5. EN 197-6 will also be published soon, introducing cement types with recycled concrete fines. Besides the mentioned standards, individual standards specify very low-heat special cement, supersulfated cement, calcium aluminate cement, and masonry cement. [16; 17; 18; 19]

The cement type, the abbreviation of addition, and strength class identification describe cement (e.g. CEM II/B-S 32,5R). A brief and simplified overview of cement types is shown in table 1. Produced clinker can be mixed with the following materials: blast-furnace slag (S), silica fume (D), natural pozzolana (P), natural calcined pozzolana (Q), siliceous fly ash (V), calcareous fly ash (W), burnt shale (T), limestone (L or LL) or recycled concrete fines (F). Standard strength classes are 32,5L; 32,5N; 32,5R; 42,5N; 42,5R; 52,5N; 52,5R, and their numerical part presents minimum normalised 28-day compressive strength. Letters L, N, and R represent the early age strength of cement. Letter R stands for higher early age strength values, N for common values and L for low values and low heat of hydration. Detailed required early age strength, usually after two days and eventually after seven days (in case of slower cement), are specified in EN 197-1. [16]

New cement type CEM II/C-M is considered a potential one for the future because of lower clinker content and the flexibility of mixing two clinker substitutors, which



goes hand in hand with CO<sub>2</sub> reduction. The combination of more substituents in Portland cement allows the utilisation of the advantages and reduces the disadvantages of the used constituent. For example, blast furnace slag can modify the properties of fly ash or limestone in Portland composite cement to reach the required compressive strength development and rheology of fresh concrete. CEM II/C-M type is not common yet because its use requires changes in concrete standards in most European countries. However, this cement is already available in certain countries. [19]

Table 1 – Simplified overview of cement types acc. EN 197-1 and EN 197-5

Standard	Main type		Type	Number of sub-groups	Clinker content [%]	Clinker substitution
EN 197-1	CEM I	Portland cement	CEM I	-	95-100	no
	CEM II	Portland-composite cement	CEM II/A*	10	80-94	one constituent possible (except CEMII/A-M, CEMII/B-M)
			CEM II/B	9	65-79	
	CEM III	Blast furnace cement	CEM III/A	-	35-64	blast furnace slag
			CEM III/B	-	20-34	
			CEM III/C	-	5-19	
	CEM IV	Pozzolanic cement	CEM IV/A	-	65-89	more than one possible: silica fume, pozzolans, fly ash
			CEM IV/B	-	45-64	
	CEM V	Composite cement	CEM V/A	-	40-64	blast furnace slag + pozzolans / siliceous fly ash
			CEM V/B	-	20-38	
EN 197-5	CEM II	Portland-composite cement	CEM II/C-M	-	50-64	a possible combination of two constituents
	CEM VI	Composite cement	CEM IV	4	35-49	blast furnace slag + one other constituent
*Note: Except CEM II/A-D						

Central Europe's most common cement types are currently CEM I, CEM II (A-L, A-LL, B-LL, A-S, B-S, A-M, B-M), and CEM III, mainly used for mass concrete structures. Figure 1 shows the market share of cement types in Austria, the Czech Republic and Germany in 2020. Austria and Germany use much less CEM I; by contrast, CEM I still predominates in the Czech Republic. This difference is also clearly visible when comparing the average clinker factor below: [5; 6; 20; 21; 22; 19]

- Austria 70%
- Czech Republic 79%
- Germany 71%

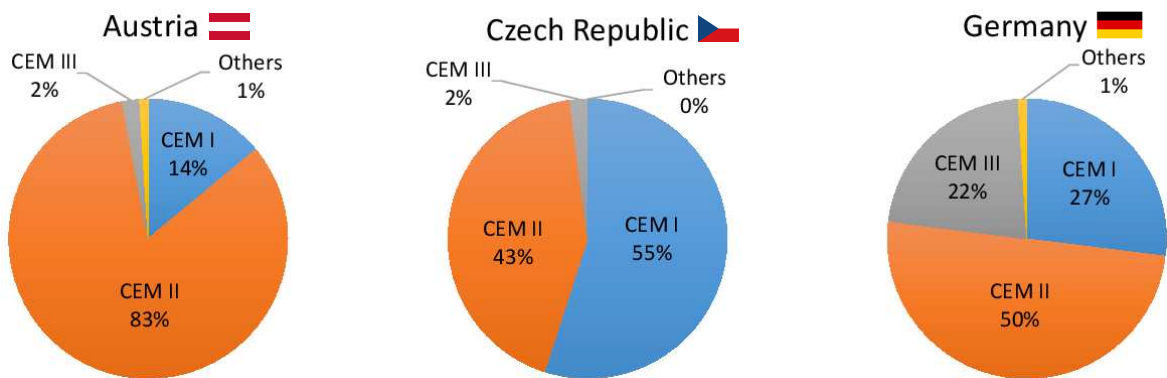

Figure 1 - Market share of cement types in Austria [6], Czech Republic [21] and Germany [22] in 2020

## 2.2 Clinker Composition

The clinker of Portland cement consists of four main clinker minerals. Two calcium silicates ( $C_3S$ ,  $C_2S$ ) play a major role in the hardening process, and two calcium aluminates ( $C_3A$ ,  $C_4AF$ ) play a significant role in the setting process and contribute to hardening only slightly. Clinker composition is described in table 2. [1; 23; 24]

Table 2 - Clinker minerals [23; 24]

Abbreviated designation	Name of the mineral	Chemical formula	Content [%]	Amount hydration heat [kJ/kg]
$C_3S$	Tricalcium silicate (Alite)	$3CaO \cdot SiO_2$	63	500
$C_2S$	Dicalcium silicate (Belite)	$2CaO \cdot SiO_2$	20	260
$C_3A$	Tricalcium aluminate	$3CaO \cdot Al_2O_3$	8	900
$C_4AF$	Tetracalcium aluminate ferrite	$4CaO \cdot Al_2O_3 \cdot Fe_2O_3$	7	300

The remaining two per cent of clinker consists of free  $CaO$ ,  $MgO$ , and other constituents. The hydration heat of Portland cement (CEM I) is approximately 400 – 500 kJ/kg when considering total hydration, which is not reachable in practice. The measurable value at standard conditions is between 300 and 400 kJ/kg, depending on the cement strength class. [24]

## 2.3 Hydration of Cement

Cement hydration is a chemically very complex and challenging process and has not yet been fully described in scientific society. The target of the chapter is not to describe the process in full detail but to outline which processes during hydration take place and how they probably influence the changeable intensity of hydration heat development. Progress of hydration reaction, related chemical processes and development of hydration heat could be described using a heat development diagram of a particular



cement type. Author of the thesis determined this diagram by an isothermal calorimetry test of CEM I 42,5 R. This cement type contains a minimum of 95 % clinker according to the standard EN 197-1. The remaining part is especially calcium sulfate ( $\text{CaSO}_4$ ), which guarantees a specific time of workability after mixing cement with water. [16]

Cement hydration is generally divided into three phases: induction period, setting and hardening. Progress of those three phases is plotted in the graph of heat development of the mentioned cement (Figure 2). [14]

### 1) Induction period

Several seconds after mixing cement with water, the hydration reaction of calcium aluminates starts, first  $\text{C}_3\text{A}$  and subsequently  $\text{C}_4\text{AF}$ . Very intensive development of hydration heat comes, but it almost ceases within several minutes (Figure 2). Observed intensive heat development is caused predominantly by quick hydration and conversion of  $\text{C}_3\text{A}$  into ettringite or generally Aft phases, alternatively C-A-H hydrates. Fast setting and workability loss would happen without adding the setting and hardening controller,  $\text{CaSO}_4$ , into cement because of an absence of sulfate ions. Retarding effect of sulfates on the hydration of  $\text{C}_3\text{A}$  is traditionally explained by the creation of the so-called ettringite barrier, which slows down further dissolution and hydration of clinker. However, it was proved using electron microscopy that ettringite does not produce a continuous layer at the surface of the clinker. Retarding mechanism of sulfate ions is today explained as follows. Dissolution  $\text{C}_3\text{A}$  (and other minerals) does not occur evenly on the entire surface but at certain reactive spots. If the liquid phase contains sulfate ions, their adsorption occurs at reactive locations, and the dissolution of  $\text{C}_3\text{A}$  (and hydration) is significantly slowed. [14; 25; 26; 27]

Similar rapid and time-limited heat development occurs during the hydration of pure  $\text{C}_3\text{S}$  without any  $\text{C}_3\text{A}$  and sulfates. Rapid inhibition of hydration is explained in that case by slower dissolution  $\text{C}_3\text{S}$  in a liquid, where calcium ion concentration increases. It means that "the driving force" for the dissolution of  $\text{C}_3\text{S}$  decreases, in contrast to the beginning when the concentration of  $\text{Ca}^{2+}$  in liquid is zero and the driving force of dissolution of  $\text{C}_3\text{S}$  is high. This way of explanation is the so-called geochemical principle because it is very similar to the speed control of the dissolution of minerals in geochemical processes. Immediately after the first contact of  $\text{C}_3\text{S}$  and water, fetuses of C-S-H hydrate originate. C-S-H hydrate is well-known as a critical hydration product responsible for strength. It does not create a compact and covering layer of grains and does not impede the progress of hydration. [14; 25; 26; 27]

### 2) Setting phase

The induction period ends after 2 or 3 hours, and the setting phase comes, which is characteristic of the transition of cement paste into a solid state of matter due to further development of hydration reaction. Heat flow increases again, caused by the fast hydration of  $\text{C}_3\text{S}$  and transition to C-S-H. The intensive release of heat from the end of the induction period till approximately 24 hours after mixing cement with water is called the main hydration peak. It has not been fully proven why the induction period



changes into intensive hydration. However, it is probably a continuation of the geochemical principle. The possible way of interpretation is the following. There is a lack of silicate ions at the end of the induction period but quite a lot of calcium ions. The ratio  $\text{Ca}/\text{Si}$  is lower in C-S-H than in  $\text{C}_3\text{S}$ , which blocks the dissolution of  $\text{C}_3\text{S}$ . If the calcium and hydroxide ions concentration in the liquid reaches a certain level, portlandite  $\text{Ca}(\text{OH})_2$  starts to crystallise from the liquid. That is precisely the time when the induction period ends and intensive hydration of  $\text{C}_3\text{S}$  starts, which increases heat generation. Faster dissolution of  $\text{C}_3\text{S}$  and intensive creation of C-S-H hydrates are most probably caused by the drop in concentration of  $\text{Ca}^{2+}$  in the liquid (because of the crystallisation of  $\text{Ca}(\text{OH})_2$ ). [14; 25; 26; 27]

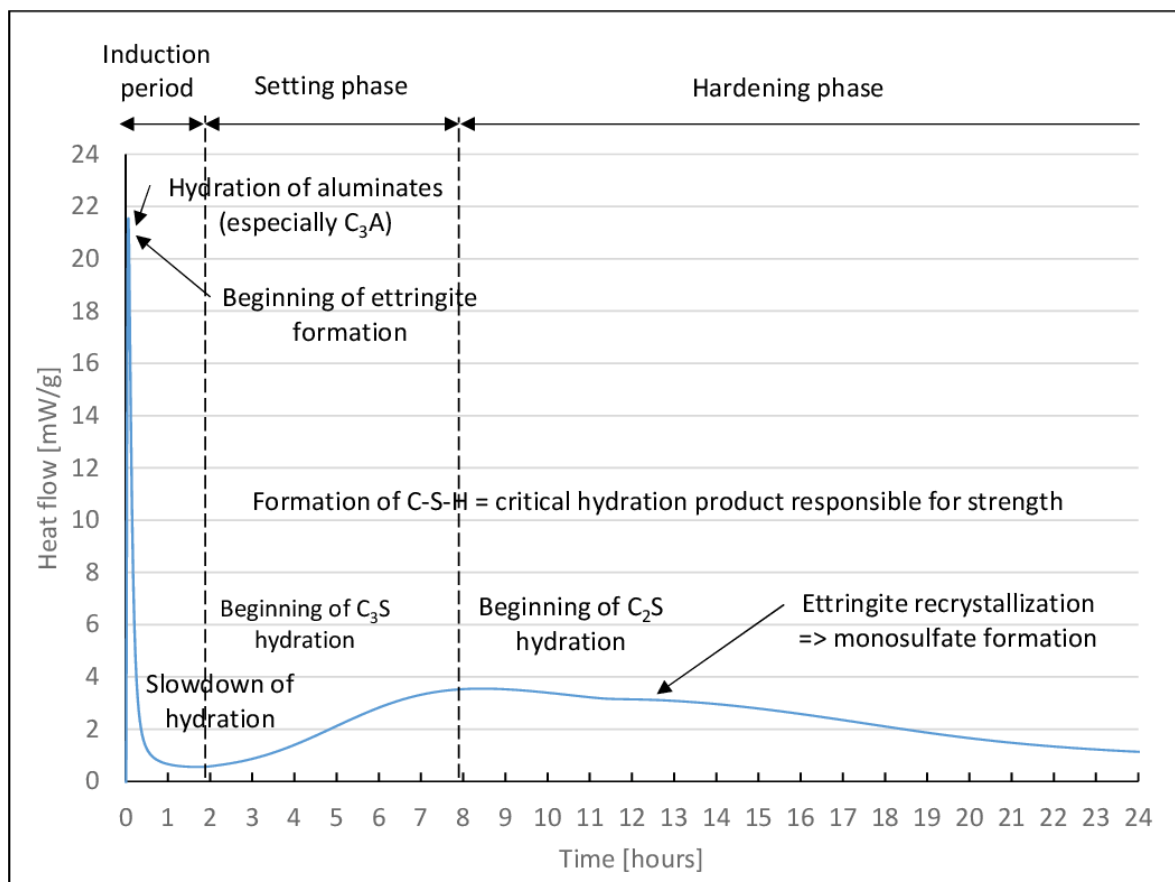

Figure 2 - Hydration heat development of cement CEM I 42,5 R [scheme: author]

### 3) Hardening phase

Hydration still continues during the hardening phase, and  $\text{C}_2\text{S}$  starts to hydrate. There is further development change; the heat flow decreases, and hydration slows. During the decreasing progress, ettringite recrystallises into monosulfate. This process releases additional heat and is visible at the curve of heat flow (Figure 2) because of a slight shape change. In that case, it is approximately 11 hours after mixing cement with water when the decrease of heat flow shortly slows. Afterwards, the heat flow of hydration heat decreases and the cement paste further matures. Decrease of heat flow of hydration decreases and gets close to zero. That is most likely influenced by



the coverage of cement grains with hydrates which reduce further dissolution and hydration of clinker minerals. Forthcoming values of heat development very close to zero do not indicate that the hydration reaction is stopped. The heat flow is just too small to measure. The hydration heat of cement is usually monitored for seven days because the values measured after seven days are very low and insignificant. [14; 25; 26; 27]

The following two figures provide more detailed information about hydration heat development (Figure 3), including compressive strength development (Figure 4) of CEM I 42,5 R, as an example of a common cement type without additions. Hydration heat was determined using cement paste with a water-cement ratio of 0,4, and compressive strength was tested using prisms consisting of standard mortar (w-c ratio 0,5). Despite that difference in composition, the figures below can provide a good idea about heat flow and compressive strength development. Figure 4 presents tested results (red triangles) and simplified strength development calculation (blue curve) based on tested results. Since strength development is simplified, it is necessary to point out that actual strength development at a very early age will be slightly different. The first two or three megapascals' development will start earlier and be slower and gradual.

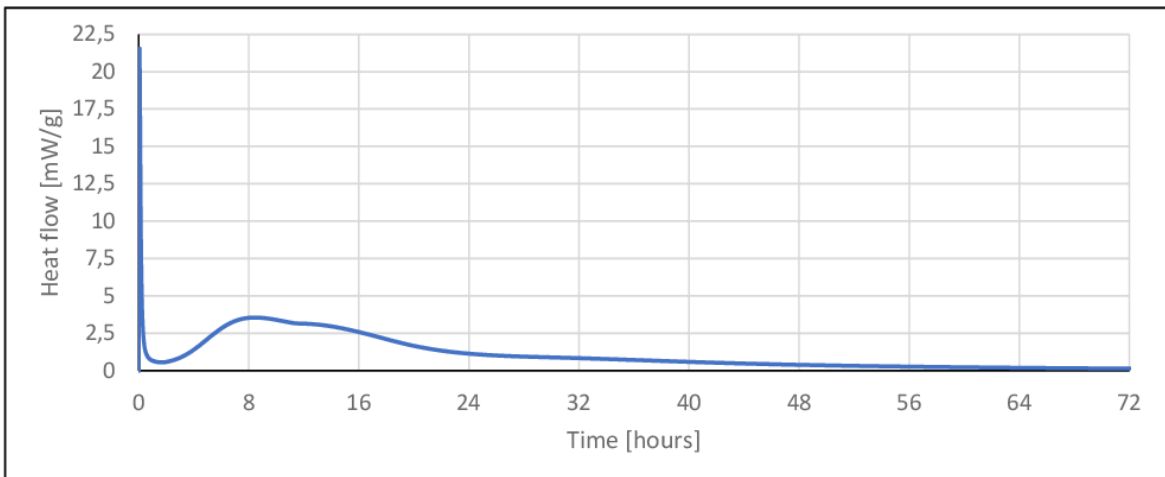

Figure 3 – Development of heat of hydration - CEM I 42,5 R [graph: author]

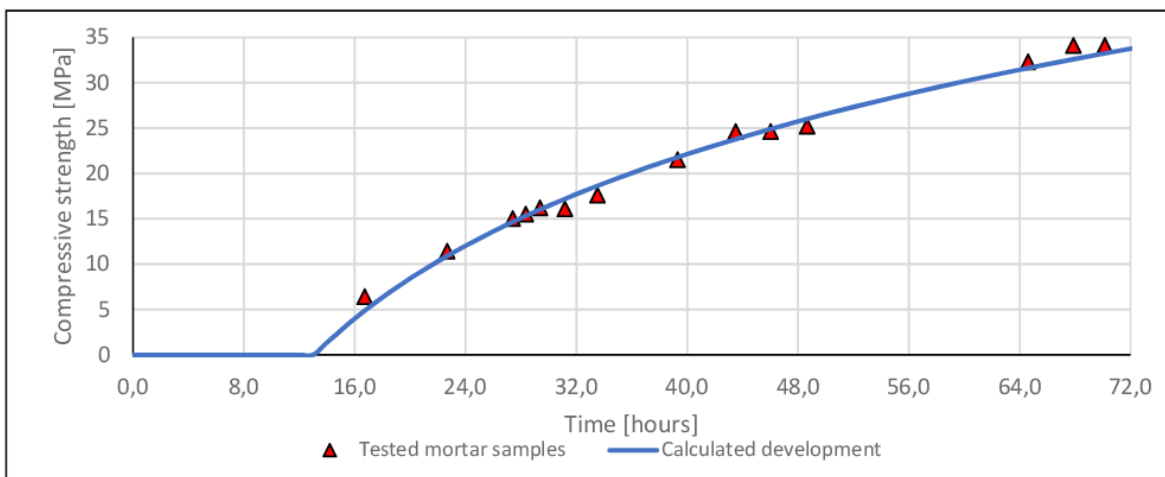

Figure 4 - Compressive strength development - CEM I 42,5 R [graph: author]

## 2.4 Determination of Heat of Hydration

It is evident from the previous chapter that the heat of hydration is one of the main characteristics of cement. Its development clearly shows the progress of hydration. The value of released hydration heat within the first seven days after mixing cement with water is provided for a particular cement type in a technical sheet from the producer. Knowing hydration heat value could be beneficial, for example, during concrete mix design for mass concrete structures. In that provided example, the contribution of hydration heat could be vital because we need to ensure that the maximum temperature in the structure will not exceed a specific limit (e.g. 70°C acc. EN 13670) and guarantee that temperature difference will not cause thermal stress. [28]

The hydration heat of cement could be determined by one of three standardised tests: solution method (EN 196-8), semi-adiabatic method (EN 196-9), and isothermal conduction calorimetry method (EN 196-11). All three methods use a specific type of calorimeter (generally laboratory apparatus for heat flow monitoring). Their principle is briefly described below. [29; 30; 31]

### 1) Solution method (EN 196-8)

The principle of the method is a determination of the difference in released heat between the dissolution of non-hydrated (fresh) and hydrated cement paste. A sample of hydrated cement paste (100g of cement + 40g of water) must be prepared in advance, stored at 20°C for seven days before the test, and ground into a powder with a maximum grain size of 0,6 mm. Dissolution of cement samples is executed using hydrofluoric acid (40%, 2600 ml) and nitric acid (2 mol/dm<sup>3</sup>, 100 ml). The value of the dissolving heat of both samples is determined in an adiabatic calorimeter – a thermally insulated tank with a thermometer and stirrer.

The mixture of both acids is poured into the calorimeter's tank (volume approx. 650 cm<sup>3</sup>). Then, a sample of cement for dissolution is added. Adiabatic conditions are assumed during the test. It means that the calorimeter is supposed to be perfectly insulated, and released dissolution heat heats only the content of the calorimeter. The value of released heat is calculated on the basis of the increased temperature in the calorimeter. According to Hess's law, the difference between the dissolution heat of non-hydrated and hydrated cement corresponds to the hydration heat of tested cement. [29]

### 2) Semi-adiabatic method (EN 196-9)

The semi-adiabatic method is also sometimes called Langavant's method. The principle of the method is a direct measuring of an increased temperature of the tested cement sample. A measurement is performed in semi-adiabatic conditions, meaning the test specimen is insulated, but certain heat losses are assumed. Langavant's calorimeter has two identical spaces for the sample. The first one is used for monitoring cement mortar hydration, and the second one, reference, contains a specimen of hydrated cement mortar, which must be older than twelve months. The tested sample



consists of 1575 g of standard cement mortar (acc. EN 196-1) with the following composition: 1350 g of CEN standard sand, 450 g of cement, and 225 g of water. The temperature development is recorded after the required amount of mixed cement mortar is inserted into a semi-adiabatic calorimeter. The heat of hydration is calculated based on the temperature difference between hydrating and already hydrated mortar samples. [30; 32]

### **3) Isothermal conduction calorimetry method (EN 196-11)**

The test is performed at isothermal conditions, which means that temperature is constant during the whole test (e.g. 20°C acc. EN 196-11). The principle is measuring heat flow, which is needed to keep a small amount of cement mixed with water at 20°C. The isothermal calorimeter is more expensive than the calorimeter of Langavant, but it provides more information which is more precise. The execution of the test is not complicated, and a relevant result could be successfully reached if the recommended procedure specified in the standard (EN 196-11) is kept, suitable tools are used, and the sample is prepared carefully. The result is the hydration heat flow curve in time (e.g. Figure 2) and total hydration heat released within seven days after mixing cement and water. The whole method is described below in more detail because those tests were performed with different cement and supplementary cementitious materials, which were later used in the practical part of this thesis. Results are subsequently presented in chapter 7.1 to point out differences in the behaviour of different cement types. [31]

#### **2.4.1 Isothermal Conduction Calorimetry Method**

The calorimeter used for the test is basically an insulated box where constant temperature is kept. A particular example could be the calorimeter TAM Air (Figure 6) produced by the company TA Instruments. This type can measure up to eight samples in parallel because it has eight channels (measuring units). Each measuring unit consists of a heat sink connected via a heat flow sensor into two chambers for samples (Figure 5). The first chamber is used for the sample of tested cement. Reference material of the same specific thermal capacity (e.g. ground quartz) is placed in the second chamber. The hydration heat of the tested cement sample goes through the heat flow sensor into the heat sink (Figure 5). This heat flow is recorded via the change of the voltage of the tested sample's heat flow sensor compared to the reference material's heat flow sensor. Heat flow sensors are very sensitive and can detect tiny differences. Additionally, heat is taken away quickly to ensure constant temperature and, thus, isothermal conditions during the test. [31; 33]

The "driving force" of heat transfer is a temperature gradient. It means that minor temperature differences have to take place during the test. Since those temperature differences are insignificant and continuously compensated by the thermostat with an accuracy of 0,2°C and less, the test could be called isothermal. [31; 34]

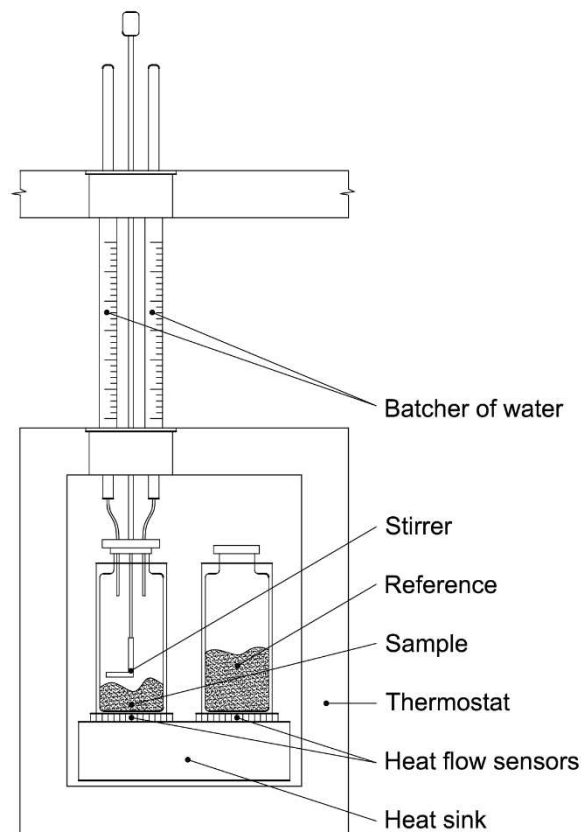

Figure 5 - Scheme of the isothermal conduction calorimetry test [scheme: author]

Before starting the measurement, cement and reference sample needs to be prepared. Cement is prepared into the ampoule, and a special tool, a batcher of water, is attached (Figure 6). The special tool allows the laboratory technician to add the prepared amount of water into the cement and mix cement paste in an ampoule while the sample is placed in the calorimeter and data are recorded (Figure 5). The standard recommends the weight of cement samples between 3 g and 10 g. The weight of sample 4 g is optimal from the execution of the test point of view. Weigh should be determined to the nearest 0,01 g. Water cement ratio 0,4 is recommended, and distilled water should be used. The weight of the reference sample is determined to reach the same value of the specific heat capacity as a sample of cement and water = measured sample. Ground quartz is usually used as a reference sample (Figure 6). [31]



Figure 6 - Samples + reference samples (left), Calorimeter including the samples (right) [photo: author]



After the insertion of samples into the calorimeter, it is necessary to wait until the temperatures are stable (e.g. 24 hours). Afterwards, the test can be started. Immediately after the beginning of the measurement, water is injected into the cement using the batcher. Cement paste is mixed directly using the stirrer. The recommended mixing time, according to standard, is 60 seconds, which is long enough for properly mixing cement paste with a water-cement ratio of 0,4. Then, the measurement takes seven days, and the recommended time duration is related to hydration heat flow values of cement, which is very close to zero after seven days – approximately 0,1 – 0,01 mW/g. Data should be recorded every 30 seconds. Every measurement should be done twice, using two cement samples; the result is the average value of hydration heat within seven days. [31]

The result of the test is a curve of hydration heat flow [mW/g] of tested cement in time and hydration heat released by a gram of tested cement within seven days [J/g]. [31]



## 3 Concrete and Compressive Strength

The previous chapter introduced cement, one of concrete's critical constituents. This chapter focuses on a concrete mix and particularly how to influence its early age compressive strength development. Generally, concrete's early age compressive strength development could be influenced by two measures:

- 1) **Adaption of concrete mix design**
- 2) **Suitable curing of early age concrete.**

The first type of measure relates to input materials, concrete mix composition and use of admixtures. The second measure involves proper curing operations and appropriate concrete temperature during hardening.

Before a more detailed overview of measures that can influence and improve compressive strength development is shared, it is necessary to mention that compressive strength is not the only property of concrete required. Even though this thesis is focused on compressive strength development and other properties of concrete are not presented, it must be evident that other property requirements are also important. An example could be the workability of concrete in any project, frost resistance in projects where exposure class XF is required or modulus of elasticity in the case of a post-tensioned and thin structure.

### 3.1 Concrete Mix Design

Concrete mix design is a very complex topic, which requires lots of practical experience and cannot be performed without concrete and input materials testing.

- The first and necessary input information are basic requirements = concrete specification (e.g. C 25/30 - XC2 - CI 0.2 - Dmax 22mm - S4), including complementary requirements, if there are some.
- Design is based on an experimentally determined relationship between concrete mix composition and properties of input materials.
- The basic principle of composition creation shows the equation below. Composition is always calculated for one cubic meter of concrete. [1; 35]

$$V_{con} = V_{agg} + V_c + V_w + V_{add} + V_{air} = 1 \text{ m}^3 \quad (2)$$

where

$V_{con}$	volume of concrete = $1[\text{m}^3]$
$V_{agg}$	volume of aggregates $[\text{m}^3]$
$V_c$	volume of cement $[\text{m}^3]$
$V_w$	volume of water, incl. admixtures $[\text{m}^3]$
$V_{add}$	volume of addition, if there is any $[\text{m}^3]$
$V_{air}$	volume of air $[\text{m}^3]$



Properties of produced concrete need to be checked regularly according to EN 206+A2. [35]

### 3.1.1 Influences on Early Age Strength

The early age compressive strength development can be speeded up by following measures in concrete mix design:

- Use of cement with higher clinker content and strength class
- Reduction of a water-cement ratio by effective use of suitable superplasticiser
- Increase in cement content
- Use of chloride-free hardening accelerator compatible with used cement

One of the mentioned measures is shown in Figure 7. Concrete mix C30/37 – XC2 – CI 0,2 – Dmax 22 mm – F4 with 340 kg/m<sup>3</sup> of CEM II/A-S 42,5 R was mixed without and with 4% of hardening accelerator Master X-seed. Figure 7 indicates the contribution of using a hardening accelerator in the concrete mix. Strength development at 20°C confirms the accelerator's significant contribution, but using a pretty high dosage of the accelerator also appreciably increases the cost of concrete mix. Curves are calculated on the basis of the concrete mix calibration using the maturity method (explained in Chapter 5), and the triangles represent validation samples stored at 20°C.

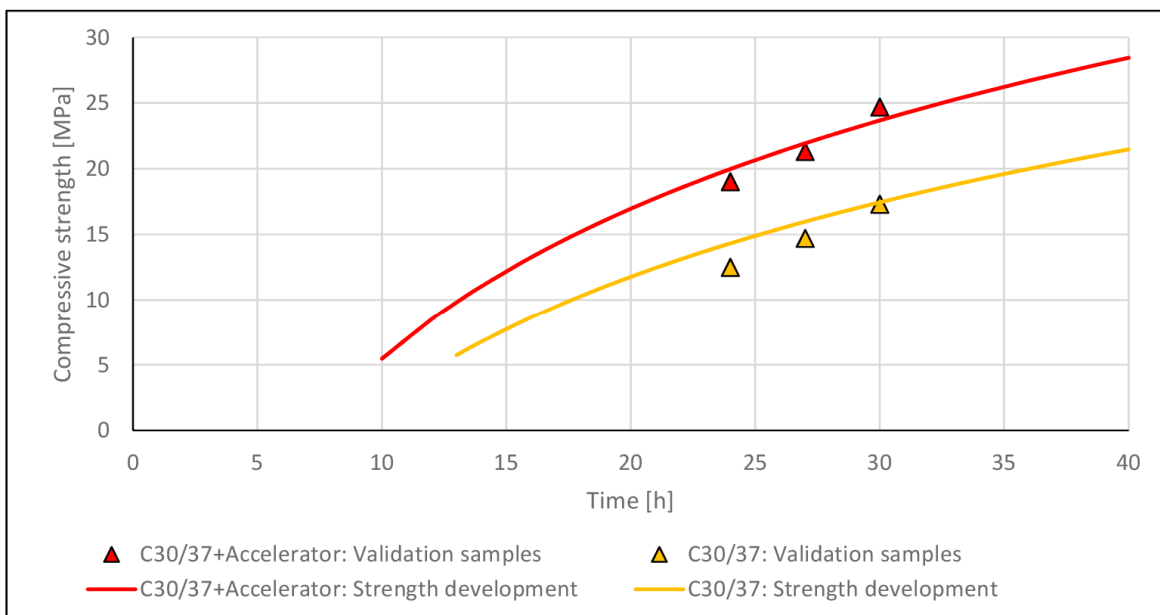

Figure 7 - Compressive strength development using hardening accelerator at 20°C [graph: author]

A more detailed overview of the adaptations of concrete mix designs and their influence on compressive strength development, which are represented by a calibration curve, are presented in the practical part (Chapter 9.3.1).



### 3.1.2 Additions

Since mineral additions are increasingly used and usually influence, in most cases slow down, compressive strength development, it is appropriate to introduce that topic briefly. Mineral additions are used to substitute a certain amount of binder (cement) or to increase the proportion of fine grains in a concrete mix. Their main goal is to improve fresh or hardened concrete properties. Those materials are characterised by grain sizes smaller than 0,125 mm and a big specific surface area of grains. In general, additions (e.g. slag, fly ash, limestone) used as clinker substitutions can be added to the concrete mix at the batching plant. However, the risk of inhomogeneity is higher than using cement with the substitutor. Standard EN 206+A2 divides addition into inert additions (type I) and active additions (type II). [1; 36]



Figure 8 – Cement and additions: limestone, blast furnace slag, fly ash, cement (II/B-S) [photo: author]

**Inert additions** are usually added to reach the closed structure of concrete or improve fresh concrete's rheological properties. From chemical and mineralogical points of view, they don't set or harden, nor after addition of exciter. Limestone or stone filler belongs to this group of addition. However, according to recent studies, certain reactivity of limestone can be observed, especially in the case of finer grinding. [35; 36]

**Active additions** actively participate and contribute to the hardening process. There are two subgroups: pozzolanic materials and latent hydraulic. **Pozzolanic materials** do not harden after mixing with water because calcium hydroxide ( $\text{Ca}(\text{OH})_2$ ) is needed to activate the hydraulic behaviour of pozzolanic material. After mixing Portland cement with water,  $\text{Ca}(\text{OH})_2$  is released and can react with added pozzolanic material. Because of that, a suitable ratio between cement (at least 40 – 50% of cement) and pozzolanic material should be kept to release a sufficient amount of calcium hydroxide for reaction with pozzolanic material. The most used pozzolanic materials are fly ash and silica fume. The most used **latent hydraulic material** is blast furnace slag. It contains a higher amount of calcium and can harden without additional  $\text{Ca}(\text{OH})_2$ , but the reaction is very slow. Calcium hydroxide released during the Portland cement reaction acts as a catalyst and can accelerate the hardening process of slag. [1; 36]



The content of used active mineral addition (type II) in the concrete mix is considered in calculating the water-cement ratio via k-value. K-value and maximum dosage, which can be included in the calculation, depend on the cement type and type of addition. The calculation concept is described in detail in EN 206+A2 and is usually also adapted to local standards (e.g. ČSN P 73 2404, ÖNORM B 4710-1). [35; 36; 37; 38]

Besides the additions described below, some other ones are also sometimes used in concrete (e.g. natural pozzolana, burnt shale, metakaolin, stone filler). For a more straightforward comparison of cement with mineral additions specified in the sub-chapters below, some physical properties of cement follow below. The **grain size** of cement is usually approximately **1 to 250 µm**, and the **specific surface area** is within the range of **250 – 400 m<sup>2</sup>/kg**. The bigger the specific surface area is, the faster and more complete the hydration is. The minimum value is 225 m<sup>2</sup>/kg, and the maximum recommended value is 600 m<sup>2</sup>/kg. However, finer cement requires more water and evinces more significant shrinkage. [23]

### 3.1.3 Fly ash

- Grain size: 5 – 150 µm
- Specific surface area: 200 – 600 m<sup>2</sup>/kg

Fly ash is a by-product of thermal power plants produced during powder coal burning. It could have variable chemical, mineralogical and granulometric properties based on the type of burned coal, location, burning and separating process. Fly ash originating from black coal has more stable properties and is more suitable for use in concrete than the one which comes from brown coal. The use of fly ash in the concrete industry is beneficial from an environmental point of view because of the utilisation of thermal plant waste. Fly ash consists mainly of SiO<sub>2</sub> (approx. 45%) and Al<sub>2</sub>O<sub>3</sub> (approx. 30%). It can improve the rheological properties of fresh concrete and the resistance of concrete exposed to a chemically aggressive environment. Substitution of fly ash for cement results in lower heat of hydration, slower early age compressive strength, and lower 28-day strength value. However, the increase of compressive strength between the 28<sup>th</sup> day and the 90<sup>th</sup> day can be slightly higher compared to reference concrete. [1; 23; 36]

Fly ash was a cheap and easily available material in the past. It changed in the meanwhile into sought-after and well-tradeable material. Unavailability of fly ash could be expected in 20 to 30 years because of strategy in the energy industry, where renewable sources of energy are supposed to be increased, and thermal power plants closed. The last significant influence of fly ash quality was the launching of SCR (selective catalytic reduction of nitrogen oxide) and SNRC (selective non-catalytic reduction of nitrogen oxide). Those technologies are implemented in the combustion system of thermal power plants and heating plants to reduce emissions of nitrogen oxide (NO<sub>x</sub>). The principle of this technology is an injection of urea solution or ammonia water into a fire chamber, and a reaction between ammonia and nitrogen oxide takes place and results in nitrogen and water. Unfortunately, combustion products (fly ash) can contain



remains of ammonium salts after the reaction. If this kind of fly ash is used in the concrete, there is a risk of releasing toxic ammonium gas from the concrete building structure. This topic is recently often discussed and investigated. The second effect of SCR or SNCR is the change in morphology and granulometry because of thermal stress, which takes place during the injection of ammonia water into a hot fire chamber. The ammonia water temperature is similar to the ambient temperature, but the fire chamber reaches between 900°C – 1100°C. Those morphology and granulometry changes can decrease fly ash's effectiveness and the fluidity and workability of fresh concrete. Using suitable concrete admixtures can solve the problems, but the previously mentioned toxic ammonium gas issue does not have a simple solution. [39]

### 3.1.4 Slag

- Grain size: 0,5 – 50 µm
- Specific surface area: 350 – 450 m<sup>2</sup>/kg

Slag is a by-product of iron production in blast furnaces. It can evince variable chemical composition and consist mainly of CaO (30 – 50%), SiO<sub>2</sub> (30 – 43%), and Al<sub>2</sub>O<sub>3</sub> (5 – 18%). As mentioned, slag as such can harden in the water but very slowly and added calcium can accelerate the reaction. A small amount of Portland cement added (which means a small amount of calcium released during the reaction) can accelerate the hardening process of slag. That allows a wide mixing range of ratios between Portland cement and slag. However, the properties and development of hydration reaction will be very different when talking, for example, about 20% or 90% slag substitution for cement. [1; 36]

Blue-green colouration of a concrete structure can occur after removing the formwork if slag (or blast-furnace cement) is used in the concrete. This colouration disappears soon if the concrete is exposed to the air. The use of slag is economically very effective for CO<sub>2</sub> reduction because of the efficient substitution of Portland cement. However, this measure loses its sustainability potential if the CO<sub>2</sub> released during iron and steel production is also considered. However, another positive aspect is the use of waste from the steel industry. Due to the CO<sub>2</sub> reduction strategies in the steel industry, the unavailability could be expected in 10 or 15 years [19]

### 3.1.5 Silica fume

- Grain size: 0,1 – 1 µm
- Specific surface area: 15 000 – 25 000 m<sup>2</sup>/kg

Silica fume is a by-product of silicon or ferrosilicon production in an electric arc furnace. Because of its fineness, it can fill the gaps between cement grains, react more effectively, and improve compressive strength in the transit zone and at the surface of aggregates. It contains 90% - 98% of amorphous SiO<sub>2</sub>. Pozzolanic reaction decreases pH in concrete (SiO<sub>2</sub> + Ca(OH)<sub>2</sub> -> CSH). Therefore, the dosage of silica fume, which can be added to the concrete mix, is limited (acc. EN197-1 11%) to avoid the decrease of pH



below 11,5 and to avoid ineffective protection of reinforcement. Silica fume improves fresh concrete properties, especially preventing bleeding and facilitating pumpability. Silica fume contributes to faster alit (C3S) hydration, and initial hydration heat flow is increased because of the presence of active  $\text{SiO}_2$ . In the case of hardened concrete, it contributes to a more solid structure, enhances the resistance of concrete exposed to a chemically aggressive environment, and the resistance to shrinkage and cracks. The price of silica fume is much higher in comparison to other additions, and its use is usually justifiable only in special applications (e.g. HPC and UHPC with compressive strength above 100 Mpa). [1; 2; 23; 36]

### **3.1.6 Limestone**

Limestone is a mineral filler produced by grinding crushed limestone. It has to contain more than 75% of  $\text{CaCO}_3$ . However, the mineralogical composition of limestone from different quarries can vary greatly, and those variations can also occur within one quarry. Due to the simple execution of grinding, it can be ground into very fine grains, which can make the cement structure more solid. Standard EN 206+A2 specifies limestone as inert addition (type I), which means that limestone does not contribute to hydration and acts as filler only. However, finely ground limestone does not act as filler only. It (at least a small amount of added) also takes part in hydration reactions, especially in the hydration of  $\text{C}_3\text{A}$ . It can slightly speed up at a very early age, but the hydration is slower on a long-term basis. The use of limestone as an addition in concrete mixes with higher requirements of exposure classes is not recommended. [19; 36]

### **3.1.7 Other additions**

The research work in concrete additions and supplementary cementitious materials is growing. It belongs to one of the most promising fields of activity regarding the future carbon emissions reduction in the concrete industry. The research initiatives are also caused by the lack of today's additions forecasted for the future. Materials potentially used in future concrete mixes could be natural pozzolans (e.g. volcanic materials), energy ashes (e.g. biochar), calcined clay and others. However, the potential of calcined clay is more likely at the level of cement production than concrete production because of the necessary sulfate balance in the concrete. That concept of cement is known as  $\text{LC}^3$  – limestone calcined clay cement. [40]

## **3.2 Curing**

When the right concrete mix for a concrete structure is chosen and fulfils all the requirements, the next important step is appropriate mixing at the batching plant and pouring concrete on the construction site. As soon as the concrete structure is poured, it is necessary to ensure proper concrete curing, which always depends on weather conditions, the type of concrete mix and the type of structure. Concrete curing should



always ensure suitable conditions for the setting and hardening process, which prevents water evaporation and provides the appropriate concrete temperature.

### 3.2.1 Moisture of Concrete

Excessive water evaporation from concrete after placing the concrete can negatively influence cement hydration and concrete quality. It can affect final concrete properties, including its compressive strength. The surface layer can especially achieve worse homogeneity and reduce the lifetime of the whole structure. This layer is critical because of concrete durability and reinforcement protection. [1]

Proper curing and avoiding water evaporation are also essential because of shrinkage reduction. Excessive shrinkage can cause tensile stresses in the concrete elements. If the tensile tension is higher than the current tensile strength of concrete, it results in cracks. Cracks allow aggressive liquids to penetrate the structure, and contributing to reinforcement corrosion and concrete degradation. [1]

There are two types of curing to prevent water evaporation and the above-discussed problems: curing by using water or membrane. The curing time depends on ambient conditions and concrete mix composition. Water curing could be spraying the water on the structure or covering the surface with a wet mat, which is regularly moisturised. Curing with impermeable membranes could be divided into two categories: covering the concrete with plastic film or using a chemical spray, which creates a thin temporary membrane and prevent water evaporation. [1]

Neglecting concrete curing can significantly negatively impact the compressive strength of concrete, especially during summer concreting when the temperature is high, and water evaporation takes place much faster because of the higher capacity of saturated air.

### 3.2.2 Concrete Temperature Limits

The concrete temperature during the setting and hardening process is a crucial parameter that significantly influences the development of hydration reaction and compressive strength development. The higher the concrete temperature is, the faster the compressive strength increases. If the temperature is too high, it can slightly decrease the compressive strength at a later age, compared to reference hardening at 20°C. Moreover, two essential limits need to be kept: [41]

- Exceeding the **maximum concrete temperature** of 70°C (acc. EN 13670) should be avoided to prevent delayed ettringite formation, which can result in cracks.
- The second necessary limit related to concrete quality, especially in massive concrete structures, is the **temperature difference** within the casting step, usually limited to 20°C – 25°C (limit depends on local standards or guidelines). In a simplified way, it is a temperature difference between the warmest and coldest locations of the concrete structure or casting step. If a higher temperature difference occurs, it leads to the development of thermal stresses, and if



the thermal stress exceeds the current tensile strength, it results in thermal cracks. In some cases, the limit is specified more strictly as a maximum temperature gradient, which means a temperature difference per meter of concrete layer.

However, the negative impact on concrete quality is usually eliminated if the temperature is kept within a reasonable range, preferably 10°C – 40°C. [1]

Lower temperature limits are also critical because if the concrete temperature during hardening decreases under 5°C, the hydration of cement is significantly slowed down. If the concrete temperature drops under 0°C, hydration is stopped, and a risk of irreversible damage is imminent to concrete due to the expansion of water in the pores. Fresh concrete temperature measured during delivery on the construction site should not be lower than 5°C (acc. EN 13670). This temperature limit is usually more strictly specified in local standards or guidelines of each country, e.g. 10°C. After pouring the concrete into the structure, the surface concrete temperature should not decrease under 0°C until a minimum compressive strength of 5 MPa is reached. Those limits come from European standard EN 13670. Regulations mentioned in American standard ACI 306 are very similar, but the minimum compressive strength is stated as 500 psi, corresponding with 3,5 MPa. Generally, keeping the concrete temperature at a minimum of 5°C before it reaches 5 MPa is recommended. Minimum compressive strength also depends on the type of structure, its geometry, exposure class and compressive strength class. A specific requirement can be stated in the project documentation. For the ability of freeze-thaw resistance of concrete without any negative impact on future concrete properties, a minimum strength of 15 MPa is recommended. [41; 42; 43]

Lower temperature limits are always related to winter concreting, and it relates to slower compressive strength development, which represents one of the crucial challenges on the construction site. Because of that, the next chapter introduces different practical measures for ensuring sufficient curing temperature in the winter, securing adequate compressing strength development, and avoiding frost damage to the concrete.

The upper-temperature limits need to be checked and maintained during the execution of massive concrete structures. It is a separate topic which usually requires suitable concrete mix design, temperature monitoring or even cooling and additional measures (e.g. keeping the formwork on the structure longer). Since the topic is not directly related to the subject of this thesis, it will not be further described.

### **3.2.3 Measures for Ensuring Sufficient Curing Temperature**

If the ambient temperature drops under 5°C during the execution of concrete structures, it is usually considered as winter concreting. If the temperature is not significantly below 0°C, the sufficient measure could be just thermal insulation of formwork/concrete. Insulation reduces concrete's heat loss, and the hydration reaction's



heat is kept more efficiently in the concrete. Deliberation, if the insulation of concrete is effective enough, needs to consider the necessary time for concrete protection, ambient temperature, concrete mix design, and structure dimensions. Small structures with a low volume ratio to a surface can be insulated problematically and inefficiently. If the insulation measure is not sufficient for keeping a suitable concrete temperature, it is necessary to heat the concrete or its close surroundings. The following text presents several solutions for keeping appropriate concrete temperature during hardening on the construction site. Some solutions are complemented by the author's own measurements.

### 1) Thermally insulated formwork

The first example describes the insulation of frame formwork. Filling the space between the steel frame with 80 mm thick thermal insulation reduces the panel's thermal transmittance  $L$  [ $W/K$ ] to approximately one-half. Achievement of lower thermal transmittance is limited significantly because of the steel frame with very high thermal conductivity ( $\lambda = 50 W/(m.K)$ ), which is approximately a thousand times higher compared to the thermal conductivity of expanded polystyrene ( $\lambda = 0,04 W/(m.K)$ ). Although this measure does not seem very effective from a thermal physics point of view, it is successfully used on construction sites across Scandinavian countries and can be sufficient during mild-frosty weather, especially in combination with increased fresh concrete temperature. A primary advantage of this solution is its simplicity. Thermal insulation is usually inserted into the gaps between the steel at the beginning of the project. Panels are used with the insulation during the project execution, and only minor adaptations are alternatively done during the assembling and disassembling the formwork. Figure 9 on the left shows an example of insulated frame formwork Framax in Sweden.



Figure 9 – Insulation of wall formwork (left), Heating of concrete with disposable cables (right) [Photo: R. Björkman, I. Beliatskli]

### 2) Electric heating with disposable cables

The second example is heating the structure with disposable cables. It is a simple solution, requiring a suitable power supply, a disposable heating cable, and additional



time for fixing the cable on the reinforcement. It is necessary to be careful during the connection of the electric circuit because it is usually done directly on the construction site. The disposable heating cable attached to the reinforcement is visible in Figure 9 (on the right), which was taken at the construction site in Poland.

### 3) Warm-air heating of slab formwork

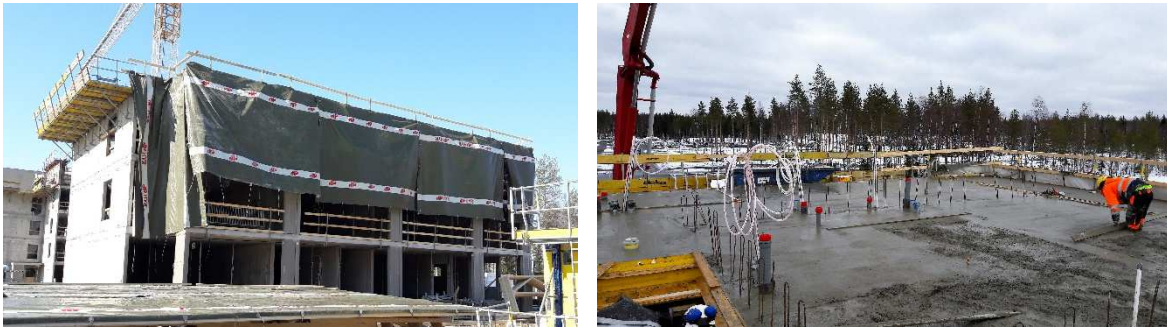

Figure 10 - Covered window openings of the heated storey (left), finishing of concrete works in Finland (right) [Photo: author]

The third example shows the heating of the storey under the hardening slab structure by gas heating appliances placed on the floor below. To ensure at least partial efficiency of the solution, it is necessary to significantly reduce the air exchange between the heated storey and the exterior or other parts of the building. A standard solution is the placement of canvas into windows (Figure 10 - left). The second important measure is covering the hardening slab to reduce the heat loss from the slab's surface and protect it against frost. That can be ensured after pouring by covering the concrete surface with a polyethene foam blanket of thickness one to two centimetres, which is commonly used for that purpose.

Figure 11 presents ambient and concrete temperature development while using this solution in Finland during the early spring. Concrete pouring was done according to the planned schedule on Friday afternoon. Since the construction site was closed during the weekend, the time was used for concrete hardening. The rapid increase in temperature development is visible at the very beginning of the measurement while the concrete was poured into the formwork. The fresh concrete temperature after delivery was 21°C. The temperature of the heated storey below the hardening slab was measured at two locations (close to the floor and below the slab formwork). The temperature curve of those two measuring points demonstrates very well the temperature stratification of the air along the room's height. Due to the sunny weather, the influence of sunshine on concrete temperature close to the upper surface is visible in Figure 11. The ambient temperature reached a maximum temperature of 5°C during the day. Unfortunately, the presented curve was recorded by the temperature sensor, which was exposed directly to the sunshine. Gas heating and covering of the hardening concrete helped to keep the concrete temperature between 16°C and 33°C during the first three days when the ambient temperature varied between 0°C and 5°C.



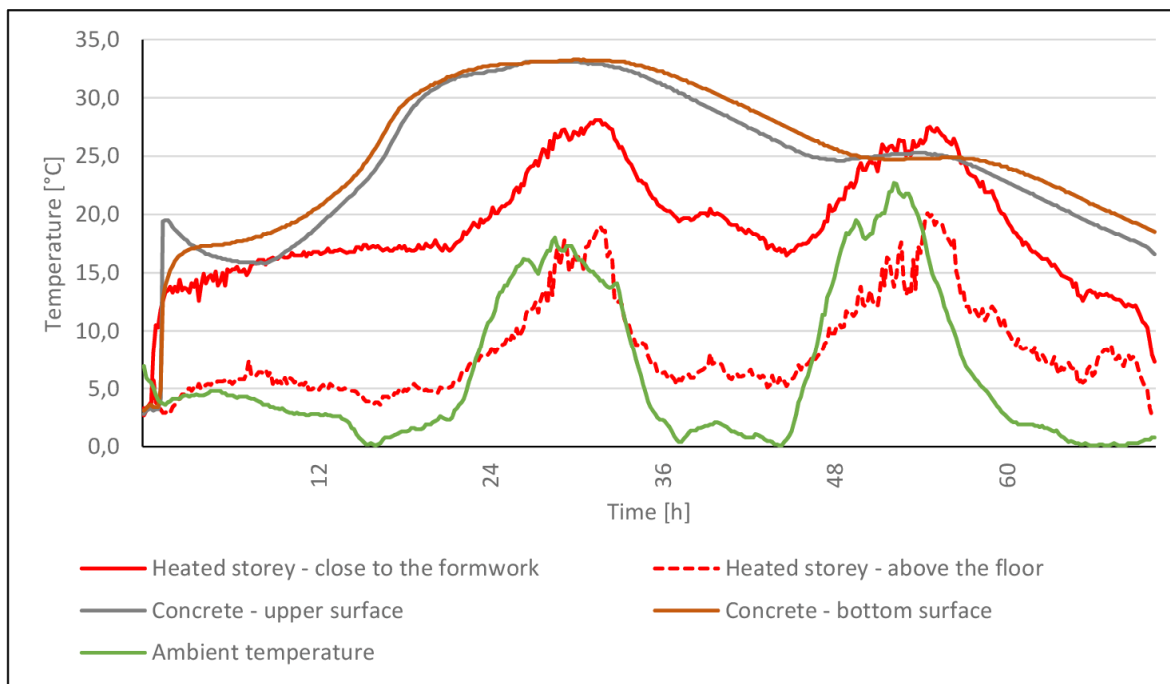

Figure 11 - Temperature development during the use of gas heating in Finland [graph: author]

#### 4) Heated frame formwork



Figure 12 – Heated formwork in use (left), concrete pouring into the heated formwork in Finland (right) [Photo: author]

The fourth example presents a heated wall-framed formwork solution. This solution could be used primarily in Nordic countries, where temperatures below 0°C can last from October to April. This specific example comes from Finland, where this particular formwork system Framax Xlife Plus Thermo, is used. The system consists of framed standard formwork Framax Xlife Plus, an additional heated insulated frame (attached on the back side of the Framax panel) and a power supply plugged into electricity. The system could be used and moved by crane, for example, as a set of three panels (2,7 x 2,7 m) assembled next to each other (Figure 12). Panels are also available in the size of 1,35 x 2,7 m and 0,6 x 2,7 m. Every three heated panels need to be connected to one power supply unit (white box – Figure 12), which includes the steering



device of the heating. Heated panels work on the principle of electric resistance heating. Figure 12 shows the heated formwork solution on the construction site in Finland close to city Oulu.

This formwork solution aims to keep one day cycle time during reinforced concrete wall execution. Stripping the wall is not crucial from a statical point of view, and sufficient concrete strength for removing the formwork is 5 MPa. Executing those structures within one day is very convenient for the schedule. Steel reinforcement of the wall is usually completed in the morning, formwork is prepared shortly before lunchtime, and after lunch, concrete is poured. The wall formwork is removed the following morning, approximately after seventeen hours.

Figure 13 presents a measurement of concrete temperature and compressive strength in the wall (Figure 12) with a thickness of 150 mm. Three measuring sensors were installed in the middle of the wall thickness. The first temperature sensor was located 35 cm from the bottom, the second sensor was placed in the middle of the wall height, and the third one was installed 25 cm from the top. The time of the pouring is indicated with "0" in Figure 13. A rough calibration curve of the used concrete mix C28/35 was developed to estimate compressive strength via the maturity method. (Note: C28/35 is not a standard strength class in all countries but is usually used in Italy or Netherlands.) The determined safety factor of maturity calculation was 3,2 MPa. It means that values of compressive strength development are decreased by 3,2 MPa. The ambient temperature was close to 0°C during the whole measurement. The compressive strength at all measured locations was sufficient for removing the formwork ( $\geq 5$  Mpa) the following morning, more precisely after 17 hours from pouring.

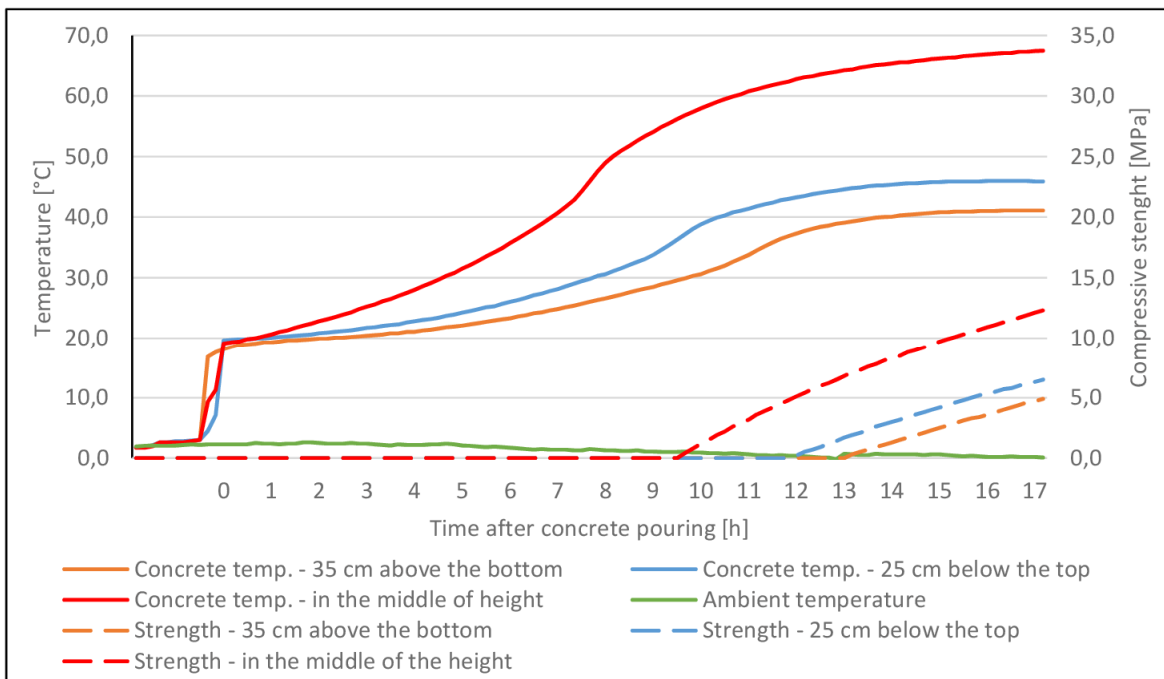

Figure 13 - Temperature and compressive strength development while using heated formwork [graph: author]



---

After stripping the formwork, covering the wall, e.g. with a polyethene foam blanket, is crucial to slow down the structure's cooling. This structure protection is important regarding concrete quality but is usually forgotten or not executed.

### **3.2.4 Construction joint**

Concerning cold weather concreting, the construction joint is a difficult part of a structure, which can not be very efficiently protected against low temperatures.

The lowest temperature is generally at the bottom part of the executed wall, where the fresh or early-age concrete of the wall is in touch with cold hardened concrete of the slab – it is a pretty big amount of cold material (concrete) with high thermal capacity. That conducts the heat out of the executing structure quite intensively. If the pouring is executed at a very low temperature, a heated disposable cable is usually placed on the construction joint to heat the concrete close to the joint and avoid the low temperature of hardening concrete.

Another tricky part of the structure could be a corner of the wall. There is no heated formwork system, which consists of heated corner elements. In presented project with heated formwork, corners were executed using reinforcement continuity systems ("feroboxes").



## 4 Compressive Strength Determination

Since compressive strength is one of concrete's critical properties, there are many methods for its determination. During construction, estimating early-age compressive strength could be beneficial for shortening the cycle times or optimising the construction processes. Later on, the compressive strength of hardened concrete is relevant to the proper operation of the structure. However, it is vital to focus on the method's reliability and accuracy of determined strength value to keep the execution of the construction safe. Several destructive and non-destructive methods for compressive strength determination are used in construction practice. The following chapters describe those methods in detail, including the suitability of the application.

### 4.1 Destructive testing

The destructive methods measure investigated property (compressive strength) of the concrete directly. As the title indicates, the sample of concrete is irretrievably damaged. Destructive methods include testing the created sample or drilled cores in the compressive strength testing machine (a press).

#### 4.1.1 Sampling

Testing of concrete samples in a compressive strength testing machine belongs to the most often used test for proving or verifying early-age or later-age compressive strength. The principle of the test is loading the test sample (usually a cube or cylinder) in the testing machine until the specimen is damaged. Compressive strength is calculated based on maximum load, which means maximum loading force right before the damage of the sample. For getting relevant information about the compressive strength of a material, it is vital to focus on the proper creation of test samples, curing of test samples, and execution of the test. [44]

The sampling is usually done at the concrete plant, construction site, or laboratory. Before the sampling, the batch of concrete used for sampling needs to be at least 1,5 times the estimated volume for testing samples. The sample of the material should be batched following the recommendation in EN 12350-1. Subsequently, concrete is filled into the moulds, which should have an inner surface treated with a release agent. Standard EN 12350-1 introduces four manners of concrete sample compaction (small vibrating needle, vibrating table, steel tamping rod, wooden tamper) and a vibrating table and steel tamping rod are mainly used. Filling the mould in two layers is recommended if the vibrating table is available and used. If the vibrating table is not available, a tamping rod is usually used (Figure 14, right) with a diameter of 16 mm and a length of 600 mm. Filling of mould is then recommended in three layers, and every layer is compacted with evenly distributed 25 strikes of the tamping rod. Tightly hitting the mould's sides with a rubber mallet after compaction of every layer makes bigger air pores escape from the concrete. Excess concrete is removed using a trowel, and



the surface of the concrete level is finished with the top of the mould. The last step is putting on the mould cover to prevent concrete dehydration. [45; 46]



Figure 14 - Cube sampling on the construction site [photo: author]

The curing of the samples should be executed according to EN 12390-2. Samples should be stored in a closed mould for at least 16 hours but no longer than three days at  $20^{\circ}\text{C} \pm 5^{\circ}\text{C}$ . Samples should not be exposed to any vibration to avoid the segregation of aggregates of recently poured concrete or microcracks during the beginning of the setting. After the demoulding, which means the latest three days after creation, samples should be cured in the water or at high humidity  $>95\%$  at a temperature of  $20^{\circ}\text{C} \pm 2^{\circ}\text{C}$ . [46]

Before the testing, a specimen is taken out of a water bath or room with high humidity. A sample is weighted, and its dimensions are measured. In the case of the determination of density, a sample is weighted underwater as well. After wiping the water from the surface, a specimen can be put into the compressive strength testing machine, and the test can be started. The loading pace should be  $0,6 \pm 0,2 \text{ Mpa/s}$  ( $13,5 \text{ kN/s}$ ) in conformity with EN 12390-3. As already indicated, compressive strength is calculated based on the maximal force loading the sample's surface ( $22500 \text{ mm}^2$  in the case of standard cubes) before the damage of the material. The tested value of compressive strength is rounded to  $0,1 \text{ MPa}$ . [44; 46]

Plastic moulds, especially the cheaper ones, can have bulged surfaces after a specific time of regular use. It can be caused by using air pressure for the demoulding of the specimen. It is recommended to check the condition of the moulds from time to time. Bulged mould influences the shape of a specimen, and it could affect the compressive strength result as well. If the surface of a sample is bulged, it can decrease

the surface in touch with a testing machine, and by that tested compressive strength value can be lower than the actual one.

If the rules and recommendations mentioned above are kept, a great advantage of this method is its accuracy. However, the measured value is valid for a tested sample and can't be the same as the compressive strength of the structure because the curing conditions, such as temperature and humidity, are different.

### 1) Influence of curing temperature

The following small author's experiment illustrates the influence of temperature on early-age compressive strength and points out that the cube's compressive strength does not always represent the strength of the structure. A small test consists of compressive strength monitoring of three cubes sampled on the construction site and strength monitoring of the concrete slab. The cubes were stored in the office at approx. 19°C, and the slab was exposed to ambient conditions approx. 6°C. Both cubes and slab were monitored using the maturity method with a calibration curve of the used concrete mix (detailed description of the method in Chapter 5). In addition to non-destructive concrete monitoring, cubes were destructively tested after approximately four days.

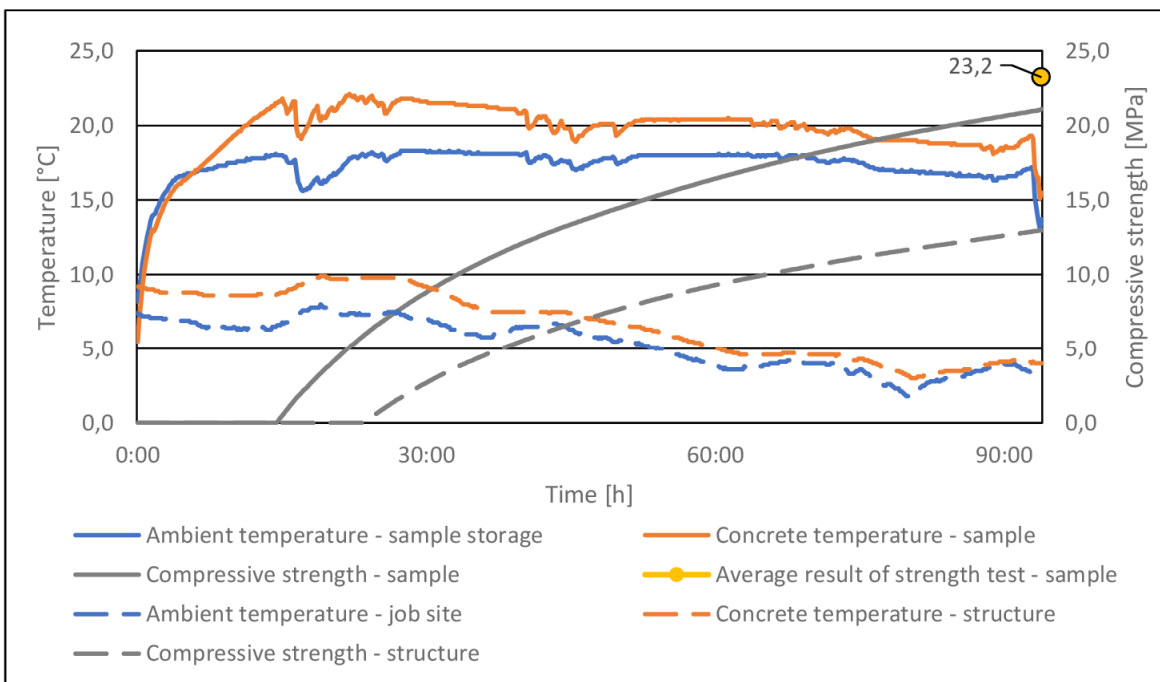

Figure 15 - The influence of curing temperature on compressive strength (cube vs. slab) [graph: author]

Figure 15 presents temperature and strength development. At the time of testing, the non-destructively determined strength of cubes was 21 MPa, and the destructively tested average result was 23,2 MPa. The deviation between both methods is within the safety factor (described in Chapter 5.2.1). At the same time, the non-destructively determined strength of a concrete slab was only 13 MPa, which is a significantly lower value due to the slower hydration process at low temperatures. However,



it is important to emphasise that the pouring was during winter, and a significant deviation between the sample and structure affected by low temperature was expected.

This example presented in Figure 15 is related to early-age compressive strength. The influence of curing temperature can also be observed at 28-day, 56-day, or 90-day strength, but the effect is almost the opposite. If the concrete in the structure matures at significantly higher temperatures than 20°C, e.g. 50°C, a slightly lower value is expected at a later age than in the case of sample cured at 20°C. Also, lower temperatures, e.g. 10°C, can slightly improve the strength at a later age. [1]

## 2) Influence of humidity conditions

Different humidity conditions can also cause variations in the compressive strength between samples and structures. The following small author's test illustrates the influence of humidity conditions on 28-day compressive strength. Six cube specimens of ready-mix concrete C25/30 – XC2 – Dmax16 – S4 were created and adequately compacted. All cubes were demoulded after 24 hours and cured at two different conditions. Three samples were stored in a water bath at 20°C, and another three pieces were exposed to air in a room with relatively low humidity and temperature of 20°C. Table 3 presents the results. Specimens cured in a water bath evinced significantly higher strength than samples exposed to low humidity, and the average difference between differently cured samples was 7,5 MPa. It confirms that in the case of insufficient moisture curing of concrete on the construction site, it could be a difference between the sample's compressive strength and the structure's compressive strength. However, it is crucial to mention that the advantage of a structure is a better ratio between the volume and surface compared to the cube sample. This fact slightly helps slow the water evaporation and keeps the water in a structure for a better hydration reaction in comparison with a cube sample.

Table 3 - Comparison of 28-day samples cured at different conditions

No.	Curing conditions	Weight [kg]	Compressive strength [MPa]	Average compressive strength [MPa]	Difference [MPa]
1	20°C, RH ≈ 40%	7,494	32,9	33,1	7,5
2		7,461	34,4		
3		7,393	32,1		
4	20°C, water bath	7,831	40,1	40,7	
5		7,930	41,2		
6		7,818	40,7		

Determination of early and later-age compressive strength using cubes or cylinders is the most common method of testing. The test can provide exact results if the sample is appropriately poured, compacted, cured and tested. During the interpretation of the test results, it is necessary to consider that early-age samples usually mature at different conditions than concrete in the structure. Compared with non-destructive



testing, the method requires more effort because of sampling, transport of the samples, storage and testing. A significant advantage of the method compared to non-destructive testing is full acceptance by authorities during the project execution. A good example could be the state-owned companies which administrate the execution of infrastructure projects in the whole country (such as the Road and Motorway Directorate in the Czech Republic, the National Motorway Company in Slovakia, or the National Infrastructure Developer in Hungary). Those authorities usually do not accept any non-destructive testing method during project execution.



Figure 16 - Compressive strength test (left), structure after cores drilling (right) [photo: author]

### 4.1.2 Drilled Cores

If the concrete in the structure needs to be destructively tested, core drilling is a suitable method for this investigation. The core cylinder is drilled and tested as a typical specimen in the compressive strength testing machine. The technique is not commonly used for early-age compressive strength testing during project execution due to its labour intensity. The whole testing process requires a lot of effort and manual work, especially transporting the drilling machine and its assembly and drilling of the concrete core on the construction site. Additionally, both surfaces in touch with the compressive strength testing machine must be perfectly flat. Both bases of the cylinder need to be brushed or levelled using a sulphuric solution. The further disadvantage could also be the hole in the structure (Figure 16, right), which needs to be filled with other material. If the test is correctly executed, the result is exact and representative of the concrete structure. The most common use is verifying existing old structures' compressive strength, e.g. before reconstruction or extension.

### 4.1.3 Samples in the structure

The principle is the creation of a sample which is stored in the structure, e.g. cylinder cast and stored in the slab. Since the concrete specimen is exposed to the same conditions as the structure, this method could provide the compressive strength value, which is very similar to the strength of the structure. The technique is not common in Europe, but it is well-known in the USA or Canada and described by standard





ASTM C873. There are also disposable plastic moulds made particularly for this purpose, inserting in the structure and easily removing a sample before testing. Testing of compressive strength is the same as testing of regular samples. [47]

## 4.2 Non-destructive testing

While the destructive method determines compressive strength directly, non-destructive methods determine compressive strength by measuring other properties converted via a regression relationship into compressive strength. The damage to a structure or a concrete sample using non-destructive testing is zero or negligible. An example of minor damage caused by a rebound hammer could be a plunger's imprint on the structure's surface. The most common non-destructive methods are surface hardness, ultrasonic, and maturity methods. [48]

### 4.2.1 Rebound Hammer

The term surface hardness method became a synonym for using a rebound (Schmidt) hammer. A rebound hammer is used quite often for the determination of compressive strength because of the simple process of its use. The principle is an estimation of compressive strength based on a hardness indicator. Predecessors of the rebound hammer were different types of penetrations tests which consisted of driving specific objects with defined shapes into the concrete using defined force. An interesting example could be one of the first methods introduced by the Soviet professor Skramtajev. He used to shoot with a revolver "Nagant" at the structure from an eight-meter distance. Afterwards, he calculated the volume of the idealized cone created by the bullet in the concrete and converted the determined volume via regression relationship on the compressive strength of the concrete. [48; 49]

The first type of rebound hammer was developed by Swiss engineer Ernst Schmidt in about 1950. Swiss company "Proseq", founded in 1954, traditionally offers the most extensive range of rebound hammers. Offered rebound hammers differ in the mechanical structure, size, and energy of executed impact. [4; 49]

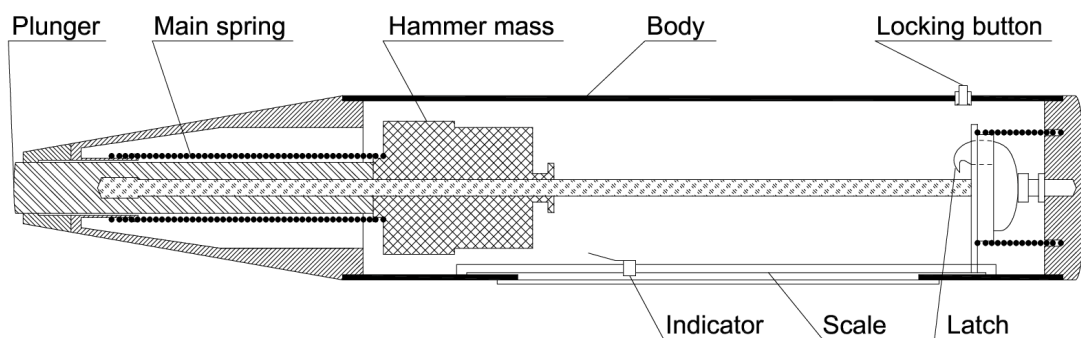

Figure 17 - Scheme of ordinary rebound hammer Schmidt N [scheme: author]

The most widespread rebound hammer for regular use is still Schmidt N, with an analogical scale of rebound value. The structure of this type of hammer hasn't almost



changed since 1965. According to the producer's information, the range of use is from 10 MPa to 70 MPa of cube compressive strength. The energy of the impact is approximately 2,25 J. The principle of hardness determination consists of measuring rebound, particularly the length of a hammer mass's return path, which is displayed on the scale of a hammer. Figure 17 presents a scheme of a standard rebound hammer Schmidt N. [48; 49]

Today's alternative to the hammer Schmidt N is the digital hammer SilverSchmidt with a range of use from 10 MPa to 100 MPa. The principle of measuring is slightly different, and it is based on the rebound coefficient "Q", which is acquired by measuring the velocity impact and rebound immediately before and after impact. The rebound coefficient is calculated as rebound velocity divided by input velocity expressed in percentages. The device uses optical sensors for measuring the velocity and shows the rebound coefficient value on the device's display. The rebound coefficient is independent of impact direction compared to the simple rebound value measured by Schmidt N, which needs to be adjusted (Figure 75) due to gravity. If the very early-age compressive strength needs to be determined, the suitable hammer can be SilverSchmidt L with a mushroom plunger, which allows the determination of compressive strength within the range of 10 MPa to 30 MPa. Figure 18 shows the rebound hammer Schmidt N, SilverSchmidt N, and SilverSchmidt L with the mushroom plunger. [48; 50; 51]



Figure 18 - Schmidt N, SilverSchmidt N, SilverSchmidt L with mushroom plunger [photo: author], testing anvil [51]

A regression relationship between the hardness indicator and compressive strength needs to be used to determine compressive strength. Some general relationships are available in the literature, or the regression relationship could be determined experi-

mentally for specific concrete mix designs. Because this method is very often considered the main competitor of the maturity method, more details related to measuring with Schmidt hammer and regression relationships are provided in Appendix 1.

Determination of compressive strength by rebound hammer can provide reliable results if the whole measurement is executed correctly and a suitable regression relationship is used. The most accurate results can be obtained if the regression relationship is determined for the used concrete mix design (note: this is not possible in the case of testing old existing structures, but that is not the topic of this thesis). The technician who works with the rebound hammer should be trained for it and know the principles of the tests and evaluation. It is also crucial to check the smoothness of the tested surface to reduce the deviations caused by the bumpiness of the surface.

The wrong procedure of execution could provide significantly inaccurate results. An example could be the use of SilverSchmidt L with the mushroom plunger. In the case of this rebound hammer, the perpendicular position to the tested surface is essential because slight deflection can influence the accuracy of the result. [50; 53]

#### 4.2.2 Ultrasonic method

The ultrasonic pulse velocity method is usually used to determine concrete quality or its physical-mechanical properties. The principle is based on measuring the ultrasonic pulse velocity through the tested material, which depends on the quality of the tested material. In the case of sufficient concrete quality, the ultrasonic velocity is higher ( $> 4000$  m/s). Contrarily, the ultrasonic velocity in low-quality concrete is lower ( $< 3000$  m/s). The method is very convenient for determining the modulus of elasticity or uniformity of concrete because the ultrasonic pulse velocity in a material is affected by the modulus of elasticity and compactness of concrete. In practice, the method is useful for inspecting old existing structures or determining the modulus of elasticity in laboratory conditions. [48]

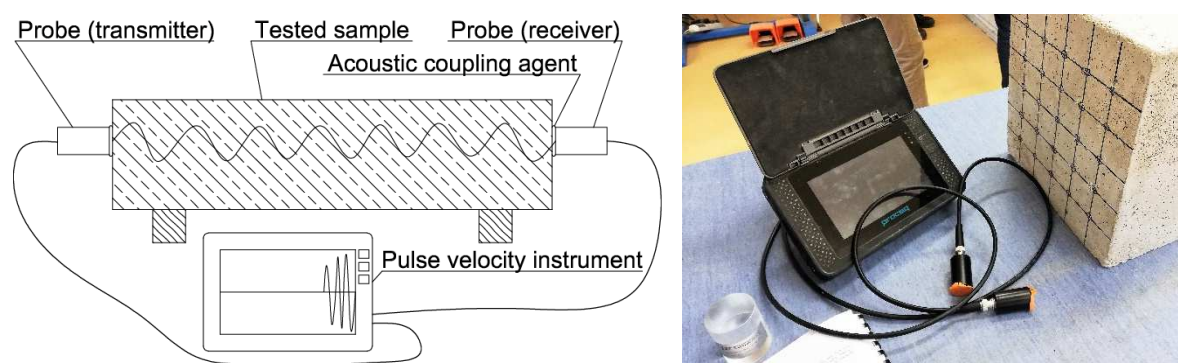

Figure 19 - Ultrasonic instrument - scheme and picture [picture: author]

The method is described in the standard EN 12504-4. The ultrasonic instrument consists of a portable testing unit and two probes, one for transmitting and one for receiving the ultrasonic pulse (Figure 19). Complete contact of the probes with a testing sample or structure is assured by an acoustic coupling agent (plasticine or gel). It prevents



an air pocket between the probe and the concrete surface and the following errors in measured transit time. All the measured values need to be adjusted because the time when the ultrasonic pulse goes through the acoustic coupling agent (or eventually the structure of probes) should be subtracted. This so-called dead time is determined via the calibration rod with a known time characteristic - the glass cylinder in Figure 19. If the plasticine layer is exchanged or significantly deformed and the layer is thinner, the dead time should be determined again. Commercial portable devices allow the determination of dead time before the measurement. Later, they automatically adjust all measured values. [4; 48; 56]

Regression relationships for estimating compressive strength based on ultrasonic pulse velocity vary with the concrete mix composition and can evince certain inaccuracies. The measurement of ultrasonic pulse velocity is also sensitive to the moisture of the material. The presence of reinforcement should always be considered because the influence on ultrasonic velocity can be significant, mainly if the steel bar lies in the direction of the measurement. Using this method and gaining reliable estimations of compressive strength can be very problematic on the construction site due to the effects which can occur. Measurements with portable ultrasonic devices require a trained technician to adjust the device before use and correctly perform the measurements. [48]

### **4.2.3 Other non-destructive methods**

There are also some other methods which are not used that often. One example could be different types of penetration-resistant techniques, which are considered more as predecessors of rebound hammers. Another example can be the so-called pullout test. The test principle is pulling out of a steel bar with widened parts poured into the concrete. Current compressive strength is estimated based on the pullout force. [4]

The maturity method, which plays a significant role in this thesis, is described in the following chapter in more detail.

## 5 Maturity Method

Maturity methods for estimating the compressive strength of early-age concrete are known since the 1950s and are accepted in international standards (EN 13670; ÖNORM B 4710-1; DIN 1045-3). The maturity is generally described by equation (3). The method uses a simple principle of the relationship between compressive strength and temperature history. The compressive strength of concrete is directly proportional to concrete age and temperature history of concrete. The primary prerequisite assumes that samples of the same concrete mix of the same maturity have similar compressive strength values, independently of an arrangement of temperature at the time. Figure 20 illustrates the claim above and shows the main principle. [3; 38; 41; 57]

$$M = \int_0^t f(T - T_0) dt \quad (3)$$

where

- M maturity [°Ch]
- f(T-T<sub>0</sub>) function of temperature development [°C]
- t time [h]

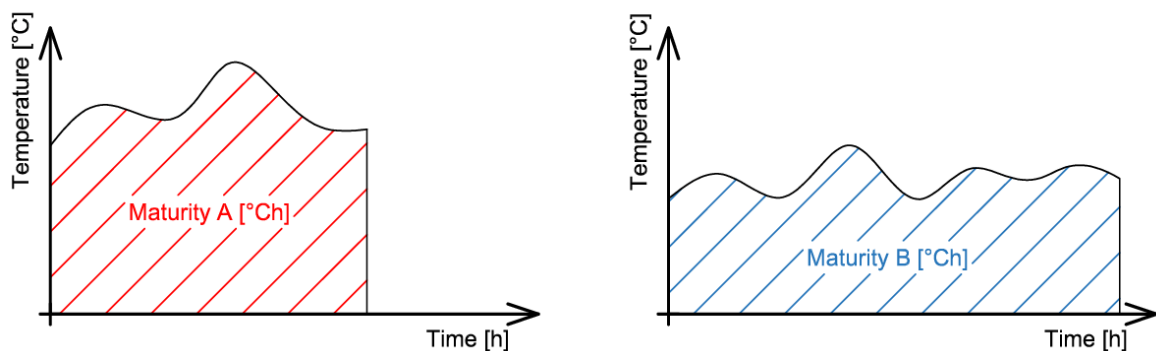

Figure 20 - Principle of maturity method [scheme: author]

Before using the maturity method, it is necessary to calibrate the used concrete mix (= to determine the regression relationship of a particular concrete mix). The calibration target is to determine the relationship between the compressive strength of concrete and maturity. Concrete maturity can be easily calculated based on easily measurable data (temperature and time), and compressive strength is a crucial property of concrete that a construction company usually wants to know.

The calibration process should be planned regarding the purpose of use of the maturity method (e.g. optimal stripping, post-tensioning). Based on the purpose of usage, the target value of compressive strength is determined, which has a crucial impact on a crushing schedule of calibration. For instance, the target value for the optimal stripping of slab formwork is usually approximately 70% of 28-day compressive

strength. All individual results of cube testing should cover a range of compressive strength close to the target value (Figure 21). [7]

Calibration usually takes place at the laboratory using concrete samples (cubes, alternatively cylinders). The whole procedure begins with casting cubes. After the casting and compaction of all needed cubes, the temperature of concrete samples is continuously measured, and maturity is calculated based on temperature development. A plan of testing individual cubes in time is prepared so that each cube is tested at a different age. Cubes are tested one by one according to the created testing plan. Each test result is assigned to the calculated maturity value. Based on all outcomes, the calibration curve is created. The concrete mix composition should not be changed after calibration; otherwise, a new calibration is required. The whole calibration procedure is described in the context of standards in Chapter 5.2. Figure 21 shows an example of the calibration curve. [7]

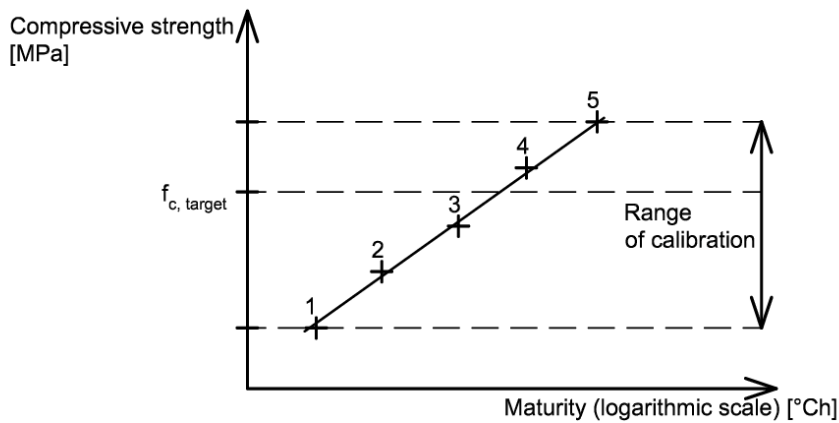

Figure 21 - Example of calibration curve [scheme: author]

As mentioned earlier, the maturity method is usually used for early-age concrete. Precisely speaking, the lowest compressive strength value, which can be determined using the maturity method, is approximately 5 MPa. The upper limit is 70% of 28-day compressive strength. Figure 22 illustrates the range of use of the maturity method.

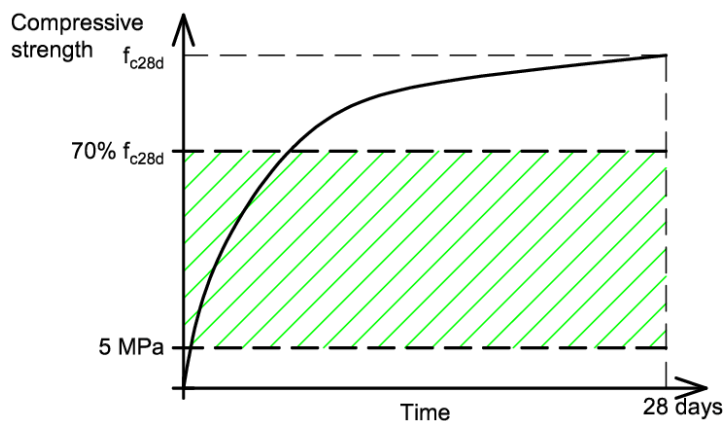

Figure 22 - Range of possible use of maturity method [scheme: author]

The lower limit is also influenced by minimal compressive strength (approx. 3 MPa) when the compressive strength test can be done precisely and without any problem in a usual testing machine. The calibration range should have a specific overlap downwards over the target value, which is why the minimum compressive strength is at least 5 MPa.

## 5.1 Common Maturity Methods

There are three maturity methods which are commonly used in construction practice: [4; 9]

- Nurse-Saul
- Arrhenius (Freiesleben-Hansen and Pedersen)
- de Vree

The Nurse-Saul method is preferred for its simplicity and relatively accurate results, while the Arrhenius method is considered an exact and more complex approach because of the concrete's non-linear hydration rate. DeVree, the improved Nurse-Saul method, tries to compromise simplicity and accuracy. [9]

Nurse-Saul and Arrhenius could be theoretically used for estimating compressive strength up to 28-day value, but the accuracy at a later age (above 70%) is not that precise. Moreover, the motivation for using the maturity method is usually related to construction processes, which are done at an early age. [10]

### 5.1.1 Nurse-Saul

Saul introduced this easy and first maturity method in 1951. Maturity is computed using the following equation [4]

$$M(t) = \sum_0^t (T - T_0) \Delta t \quad (4)$$

where

M	temperature-time factor at age t [°Ch]
T	average temperature of the concrete during time interval $\Delta t$ [°C]
$T_0$	datum temperature [°C]
$\Delta t$	time interval [h]

This method assumes a linear relationship between temperature and maturity. No compressive strength development is considered below the datum temperature (experimentally determined constant). Maturity is calculated as accumulated differences between the average temperature of the concrete and datum temperature during particular time intervals within the measured time duration. The principle of calculation is demonstrated in Figure 23. Commonly, a value of 0°C is used for datum temperature. Other more detailed recommendations of values can also be found in the lit-



erature. For precise application, the value of datum temperature should be determined for the used cement according to the procedure described in American standard ASTM C 1074. [4; 10; 8]

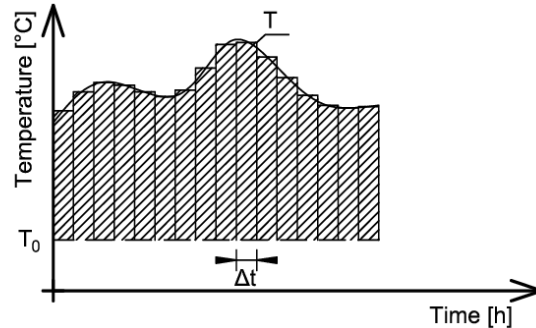

Figure 23 - Nurse-Saul: a principle of calculation [scheme: author]

### 5.1.2 Arrhenius (Freiesleben-Hansen and Pedersen)

Freiesleben Hansen and Pedersen proposed the following equation for equivalent age based on the Arrhenius equation in 1977 [4]

$$t_e = \sum_0^t e^{\frac{-E}{R} \left[ \frac{1}{273+T} - \frac{1}{273+T_r} \right]} \Delta t \quad (5)$$

where

- $t_e$  equivalent age at the reference curing temperature [h or days]
- $T$  average temperature of concrete during time interval  $\Delta t$  [°C]
- $T_r$  reference temperature [°C]
- $E$  activation energy [J/mol]
- $R$  universal gas constant, 8,3144 J/(mol.K)

The core of the equation above ( $H(T)$ ) (equation (6)) describes the relationship between the temperature and chemical activity of a hydration process. It is called "age conversion factor" [4; 24]

$$H(T) = e^{\frac{-E}{R} \left[ \frac{1}{273+T} - \frac{1}{273+T_r} \right]} \quad (6)$$

The age conversion factor states the hydration speed at a given average concrete temperature  $T$ , compared to the hydration speed at a reference temperature of 20 °C. If the concrete temperature is the same as the reference temperature, the age conversion factor is equal to one. If the concrete temperature is lower than the reference temperature, the age conversion factor is less than one. In case of a higher concrete temperature than the reference temperature, the age conversion factor is greater than one. As can be seen in Figure 24, where typical values are presented, the age conversion factor is the exponential function. [24]



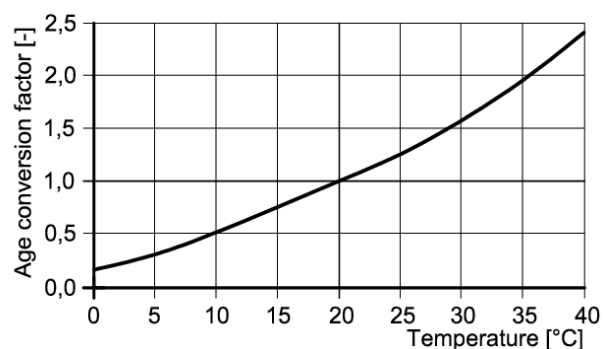

Figure 24 - Typical values of age conversion factor [scheme: author]

The specific shape of the curve defining the variation of the age conversion factor with temperature depends on the value of activation energy  $E$ . Activation energy represents the "temperature sensitivity" of the binder. Following typical values of activation energy represents a rough approach but gives acceptable results for everyday use. [4; 24]

$$\text{for } T \geq 20^{\circ}\text{C} \quad E = 33\,500 \text{ J/mol} \quad (7)$$

$$\text{for } T < 20^{\circ}\text{C} \quad E = 33\,500 + 1\,470 \cdot (20 - T) \text{ J/mol} \quad (8)$$

Figure 25 shows typical activation energy values for CEM I or CEM II/A graphically and defines the range of common values. As shown, "temperature sensitivity" increases rapidly when the temperature drops below 20°C. Recommended values of activation energy are stated in literature based on cement types. Activation energy can also be determined experimentally using 54 mortar cubes stored in 3 different curing temperatures. The whole procedure is described in detail in ASTM C 1074. [8; 24]

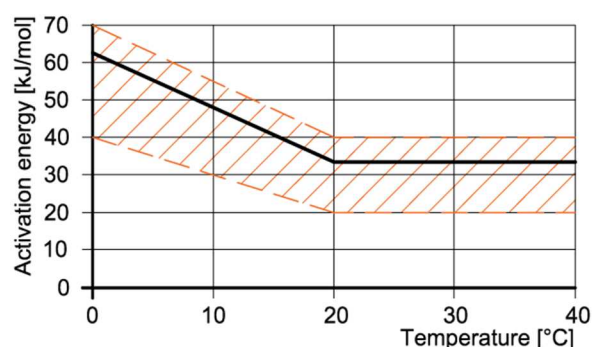

Figure 25 - Typical values of activation energy [scheme: author]

### 5.1.3 De Vree

The final form of the de Vree method was introduced in the Netherlands in 1979. This method is an improved Nurse-Saul method. The most crucial change is the implementation of weighted maturity, which considers the binder's temperature sensitivity. Maturity is calculated according to the following equation [9; 7]



$$M_w = \sum_0^t \frac{10(C^{0,1T-1,245} - C^{-2,245})}{\ln C} \Delta t \quad (9)$$

where

$M_w$	weighted maturity [°Ch]
$T$	average temperature [°C]
$C$	C-value (temperature sensitivity of binder) [-]
$\Delta t$	time interval [h]

Similarly, as the Nurse-Saul method, weighted maturity (DeVree) is the sum of the weighted maturity of the individual time intervals within the measured time duration.

C-value describes the influence of the temperature sensitivity of the binder material. It means that the C-value of the binder defines the effect of the concrete temperature on the hydration of cement. The higher C-value, the more significant effect of temperature on concrete compressive strength development. Typical C-values for CEM I can vary 1,05 – 1,30, and for CEM III 1,45 – 1,60. C-values for different types of cement can be found in literature or determined experimentally according to the procedure described in Dutch standard NEN 5970 and the following paragraph. [9; 7]

Since the de Vree method is used for experiments in the experimental part of the thesis and C-values of used cement types were tested, the procedure is described in detail below. The principle of the test is to determine the C-value, which provides the best correlation coefficient of compressive strength results and maturity of samples stored at 20°C and 65°C. [7]

It begins with creating at least two sets of three prisms 160 x 40 x 40 mm of standard cement mortar using investigated cement type (acc. EN 196-1). Immediately after casting and compaction, the mould with three prisms is wrapped into clingfilm and placed into a water bath. At least three prisms (one mould) must be stored in the water bath at 20°C and another three prisms in the water bath at 65°C. The mould is quickly removed from the water bath after appropriate curing time before the compressive strength test of the first prism's half. Prisms are demoulded and broken into two halves. One half is tested, and the rest is placed back in the water bath. Compressive strength testing times should be distributed along the following strength ranges: [7; 32]

- for cement strength classes: 32,5 N, 32,5 R, 42,5 N is range 5 – 25 MPa  
(at least two results below 15 MPa and two above 15 MPa)
- for cement strength classes: 42,5 R, 52,5 N, 52,5 R is range 15 – 35 MPa  
(at least two results below 25 MPa and two above 25 MPa)

At least five results per curing temperature need to be within the range. A suitable schedule and flexible testing times are crucial for successful tests within a required interval of compressive strength. Results out of the mentioned ranges cannot be used.

Each compressive strength result is assigned to the calculated maturity value based on curing temperature. All results from both water baths (20°C, 65°C) are plotted on one graph, where weighted maturity is at the x-axis in a logarithmic scale, and compressive strength is at the y-axis in a linear scale. The regression line is calculated using linear regression. C-value is calculated by iteration of different C-values (Figure 26). The determined C-value is the value at which the regression line has the highest correlation coefficient. In the case of the example in Figure 26 C-value is 1,30 because the coefficient of determination is very close to one ( $R^2 = 0,9858$ ). [7; 58]

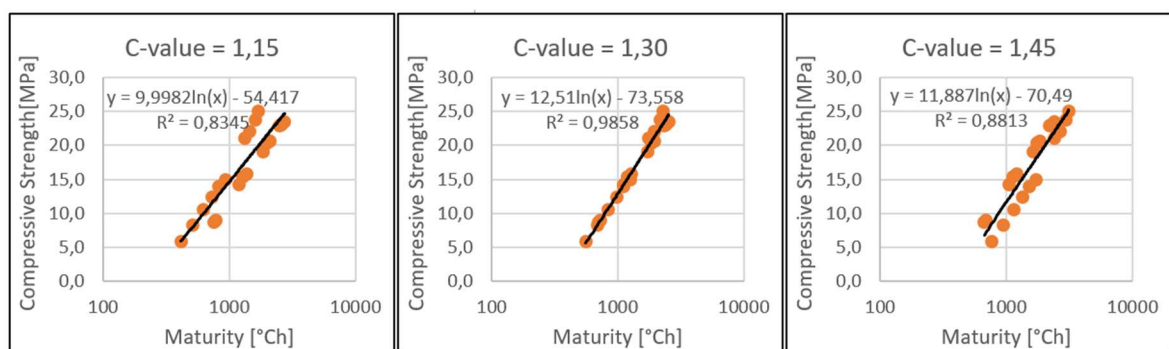

Figure 26 - Example of iteration during C-value determination of CEM II/B-S 32,5 R [graf: author]

The whole procedure mentioned above has to be performed three times from different batches of material. The final C-value of the binder is the median rounded down to 0,05. Chapter 12 includes more detailed information and the results of various cement types. [7]

## 5.2 Calibration

The procedure of calibration was generally described at the beginning of Chapter 5. This chapter points out important information in the context of standards, such as Dutch NEN 5970 and American ASTM C 1074.

### 5.2.1 NEN 5970

This Dutch standard is valid for de Vree (weighted maturity) method. For creating one calibration curve, a minimum of five cubes is required. The concrete temperature has to be recorded in the core of all cubes from the time of sample creation. According to the testing schedule, individual cubes are tested at a defined time. Compressive strength values of all cubes should cover a maximum range of 8 MPa below and up to 8 MPa above the target value (= the value needed for the critical activity, described in the introduction of Chapter 5). Results should be distributed evenly; at least two measured values should be below and two above the target value. [7]

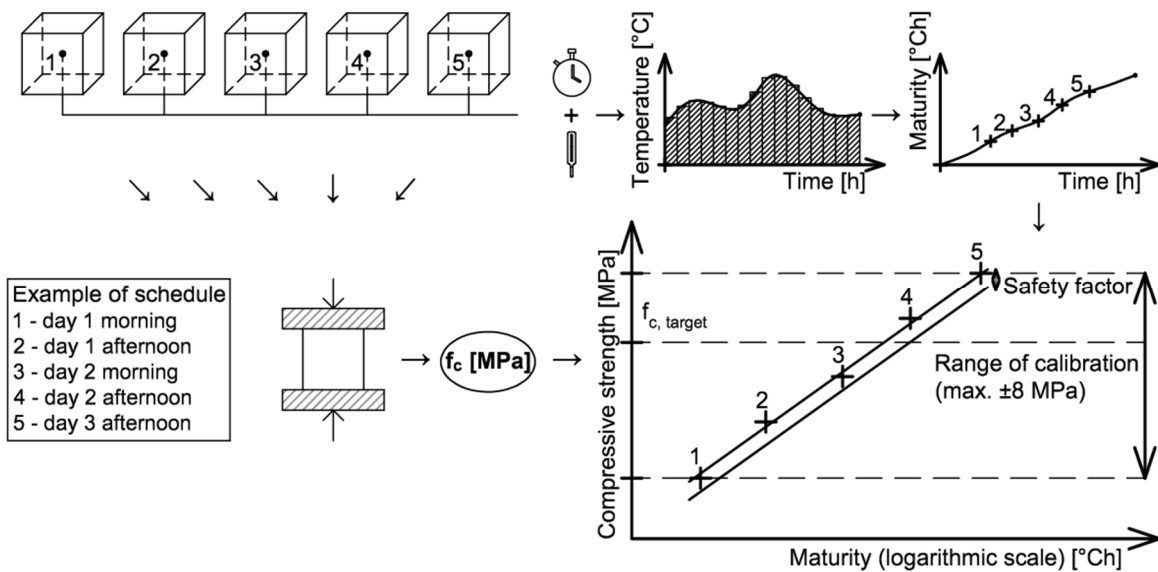

Figure 27 – Example of calibration process according to NEN 5970 [scheme: author]

Each compressive strength value is assigned to the calculated maturity value. The regression line is created based on the values of the compressive strength and maturity of all samples. With regard to possible deviations, a safety factor (explained below) is introduced into the calculation. Then, the created regression line is moved downwards using the safety factor. [7]

Calibration has to be performed for every concrete mix design, which will be measured with the maturity method. Additionally, when there are more target values to measure far from each other (e.g. 5 MPa for early striping and 26 MPa for removing slab formwork), calibration needs to be done twice, always covering the range close to one target value. NEN 5970 recommends regularly checking the calibration curve = validation every two weeks. Figure 27 summarises the whole calibration process according to NEN 5970. [7]

To determine the safety factor, a standard deviation of the calibration curve needs to be calculated according to the following equation. [7]

$$S_{ij} = \frac{f'_{c,ij} \cdot s_p}{f'_{c,p}} \quad (10)$$

where

- $S_{ij}$  standard deviation of the calibration curve [N/mm<sup>2</sup>]
- $f'_{c,ij}$  mean value of compressive strength of calibration curve [N/mm<sup>2</sup>]
- $s_p$  standard deviation of concrete production [N/mm<sup>2</sup>]
- $f'_{c,p}$  average compressive strength of production related to  $s_p$  [N/mm<sup>2</sup>]

Knowing the average strength ( $f'_{c,p}$ ) and its standard deviation ( $s_p$ ) of the production, which has to be tested and calculated in practice for 28-day strength, the standard deviation of the calibration curve could be easily calculated. **The safety factor  $S_{ij}$  x 1,0**

is recommended for reinforced concrete structures and  $S_{ij} \times 1,5$  for posttensioned structures. [7]

### 5.2.2 ASTM C-1074

This American standard applies to Nurse-Saul and Arrhenius. The basis of the calibration procedure is quite the same as in NEN 5970. However, certain parts of the process are recommended differently. Compared to NEN 5970, more samples are needed. ASTM requires at least fifteen cylindrical samples for one calibration. The temperature must be measured only in the core of two specimens. Those two specimens with temperature measurements are used for crushing as the last ones. Figure 28 compares calibration according to both standards. [8; 7]

ASTM also recommends a testing schedule with the following five ages: 1, 3, 7, 14, and 28 days. However, this recommendation is theoretical. More testing periods at an early age can result in higher accuracy of the calibration curve. In construction practice, the development of the strength-maturity relationship is usually scheduled only until the equivalent age of 7 days. [10; 8]

At each proposed age in the crushing schedule, two cylinders are crushed. If the difference between the compressive strength of the two cylinders is higher than 10%, the third cylinder must be crushed. At every test age, the average maturity is registered from temperature measurement in the core of the two mentioned specimens. Finally, the average compressive strength from all ages is plotted as a function of maturity, and the best-fit curve through the data is drawn. ASTM recommends making a validation in parallel with every measurement. No safety factor is introduced. [10; 8]

#### Calibration samples - NEN 5970

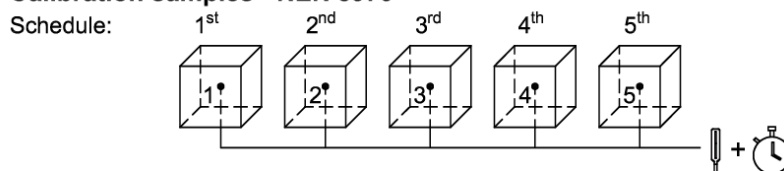

#### Calibration samples - ASTM C-1074

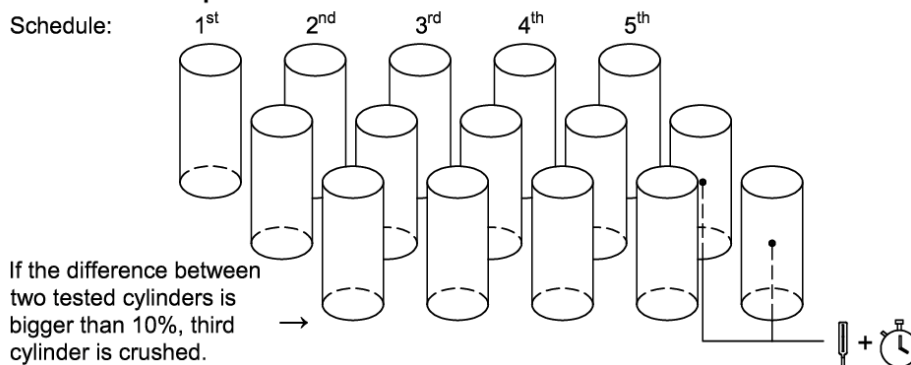

Figure 28 - Comparison of samples needed for calibration according to NEN and ASTM [scheme: author]



## 5.3 Strength-Maturity Relationship

As soon as all results from tests during calibration are known (combinations of maturity and compressive strength at different ages), it is possible to plot the calibration curve. One of those three functions is usually used [4; 10]

- **Exponential**

$$S = S_{\infty} e^{-\left(\frac{\tau}{M}\right)^{\alpha}} \quad (11)$$

- S compressive strength [MPa]
- $S_{\infty}$  limiting compressive strength [MPa]
- M maturity [°Ch] or [h] (unit depends on the type of used method)
- $\tau$  characteristic time constant [h]
- $\alpha$  shape parameter [-]

- **Hyperbolic**

$$S = S_{\infty} \frac{k(M - M_0)}{1 + k(M - M_0)} \quad (12)$$

- $M_0$  maturity when strength development is assumed to begin [°Ch] or [h]
- k rate constant [1/°Ch] or [1/h]

- **Logarithmic**

$$S = a + b \log(M) \quad (13)$$

- a constant
- b constant [MPa/°Ch] or [MPa/h]

The exponential and especially hyperbolic function represents the concrete strength development very well. The logarithmic function has certain limitations because of ever-increasing strength with increasing maturity. It underestimates very early compressive strength (generally <5MPa) and overestimates compressive strength at late ages (above 70 – 80% 28-day strength). However, the logarithmic relationship is still beneficial for the determination of common values of early-age compressive strength, which are usually within the mentioned range. Additionally, the creation of the strength-maturity relationship using the logarithmic function is easy to handle in practice. [4; 10]

ASTM C-1074 recommends the usage of the hyperbolic or exponential function. NEN 5970 recommends the use of the logarithmic function. [8; 7]

## 5.4 Validation

The goal of validation is to verify the accuracy of the calibration curve over time. In principle, validation compares the value determined by the maturity method and the value obtained by the destructive testing (in a compressive strength testing machine).

At least one test sample is created for validation using a concrete mix design to which the calibration curve applies. A specimen is covered for the prevention of evaporation

of water from the concrete surface. The temperature development of one sample is measured, maturity is calculated, and compressive strength is estimated using the existing calibration curve. The sample is crushed in a press when the target strength is reached. Finally, the value calculated using the maturity method is compared to the average value from the compression test. The validation must be done again if the difference exceeds the permitted deviation = safety factor. If the difference is again too big, the calibration curve must be developed again. The author of the thesis recommends performing validation with three samples. [7]

## 5.5 Measuring in Practice

After successfully developing the calibration curve (regression relationship), the maturity method can be used for estimating the compressive strength of early-age concrete in situ. For this purpose, it is suitable to use one of the commercial measuring systems available on the market.

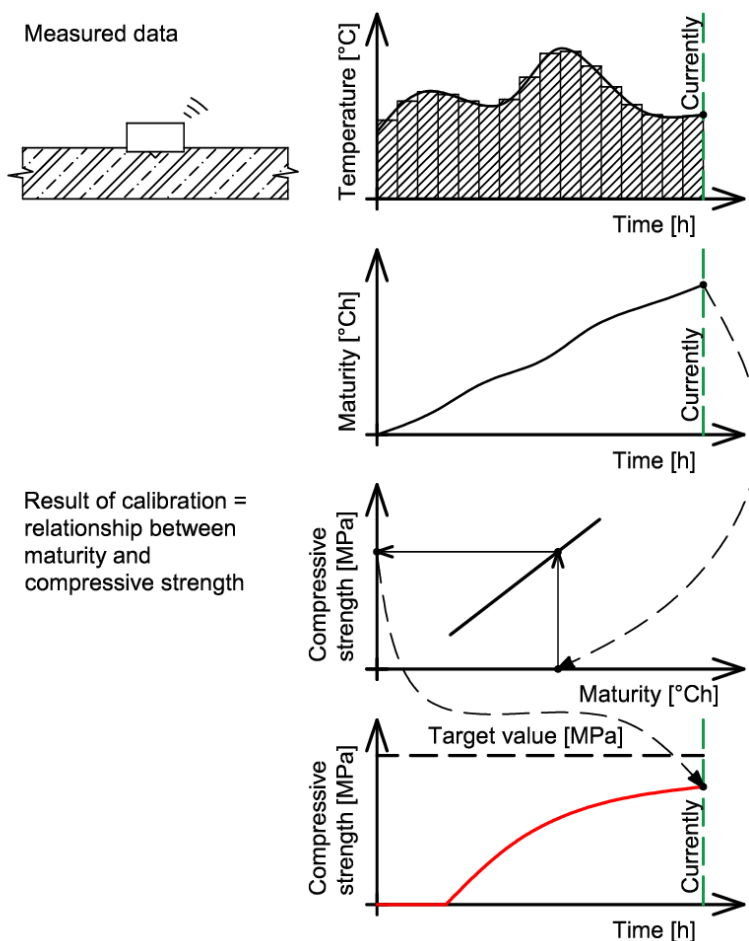

Figure 29 - Principle of measurement of compressive strength using maturity method [scheme: author]

Figure 29 demonstrates the principle of calculation. The measuring device (sensor) records temperature in time. Based on temperature development in time, maturity can be calculated using one of the methods described above (e.g. deVree, equation (9)).



The temperature graph shows the calculation of maturity as an accumulation of average temperatures (hatched columns). According to the current maturity value, the present value of compressive strength can be determined based on the calibration curve (3<sup>rd</sup> graph in Figure 29) and shown in a standard graph in time (4<sup>th</sup> graph in Figure 29).

Regarding the commercial measuring system, the following requirements should be fulfilled. The maximum inaccuracy of the measuring device should be  $\pm 1^\circ\text{C}$  according to both standards (ASTM C-1074, NEN 5970). ASTM C-1074 recommends temperature measurements at the interval of 0,5 h within the first two days and 1 hour or less later. NEN 5970 prescribes temperature measurements at least three times per hour. The weighted maturity must be calculated based on a maximum measuring interval of one hour. [8; 7]

## 5.6 Comparison with rebound hammer

Rebound hammer, in combination with the general regression relationship, usually provides very conservative results. If the rebound hammer is used with the regression relationship developed for a specific concrete mix design, the accuracy could be almost equal to the accuracy of the maturity method. However, the in-situ measurements need to be appropriately executed by properly trained technicians. Developing a regression relationship for the rebound hammer requires much more effort than a regression relationship for the maturity method. [59]

The maturity method reduces the labour intensity during the measurement. On the contrary to the rebound hammer, if the concrete mix design is not changed and the sensor is placed correctly, possible human error is decreased significantly. In addition, the maturity method can also provide a forecast of compressive strength development based on estimated concrete temperature during upcoming hardening.

## 5.7 Results of Recent Research

As mentioned in the introduction (Chapter 1), a number of papers have been written concerning the effect of concrete mix design on compressive strength development. However, clear and exact answers to questions in chapter 1.2 are still missing. Some valuable findings have already been mentioned in the theoretical part above. This chapter presents mainly contributive outcomes of the recent research in Innsbruck. [9; 60]

During the mentioned research, many concrete mix designs were calibrated using all three mentioned methods above (Nurse-Saul, Arrhenius, DeVree) at different boundary conditions. The main goal of this research was to determine appropriate boundary conditions for exact calibration, the most suitable maturity method for practice, and the effect of specific changes in a concrete mix design on the calibration curve. The final findings are summarised below and were considered during the planning of the author's research [9; 60]



Values of activation energy and C-values were experimentally determined for all four types of cement used for experiments. Results were compared with the recommended values from the literature, and both of them were used for further tests. The impact of the difference between experimentally determined and recommended values on compressive strength development was insignificant. **It showed that the literature's recommended activation energy and C-value are precise enough.** (Author's note: This statement was reconsidered based on the performed tests and calculations in the practical part – Chapter 12.) [9; 60]

Calibrations of concrete mix designs were done in four different conditions: [9; 60]

- Water tank with a controlled temperature of 20°C
- Water tank with a controlled temperature of 40°C
- Water tank with a controlled temperature of 60°C
- Semi-adiabatic conditions – calibration boxes with insulated moulds



Figure 30 - Example of calibration box, before pouring (left), after pouring (right), [photo: author]

Based on all calibrations with different cement types, calibration in semi-adiabatic conditions provides a quite precise result. Moreover, handling the calibration with insulated calibration boxes does not need too much effort, and it does not require expensive equipment in the laboratory as a water tank with controlled water temperature. **The second important finding shows that insulated calibration boxes** (e.g. Figure 30) **provide very accurate calibration results for practice.** [9; 60]

It is evident from the research results that de Vree method gives enough accuracy for measurement in the construction practice. Most of the critical operations in the construction process need a target value within the range where the logarithmic function of the strength-maturity relationship works well (5 MPa to 70% of 28-day compressive strength). Figure 31 shows that the mentioned range's approximation by logarithmic curve (line in logarithmic scale) is entirely accurate. **The third crucial finding is that the de Vree method and the logarithmic strength-maturity relationship provide precise results for construction practice.** Furthermore, the process recommended by NEN 5970 is not very difficult to implement. [9; 60]

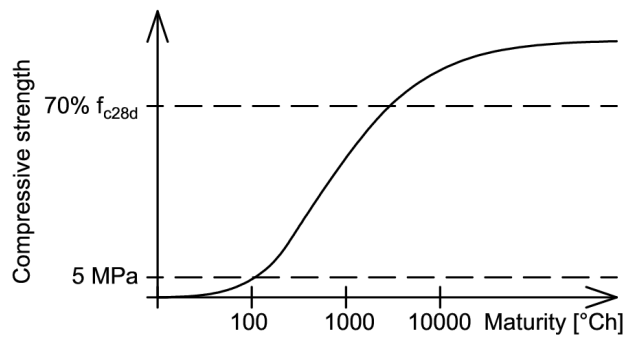

Figure 31 - Maturity-strength relationship (de Vree), maturity in logarithmic scale [scheme: author]

Two critical concrete mix design modifications occurred: the cement amount and the water-cement ratio. Results show **a slight effect of varying cement amounts on the calibration curve**. Differences  $\pm 10 \text{ kg/m}^3$  should not cause a significant impact on the calibration curve. However, **the change in the water-cement ratio can have a very considerable effect on the calibration curve**. At least a difference around 0,05 may require a new calibration curve. Because the number of those tests regarding changes in the concrete mix design was limited, research presented in the practical part of the thesis provides more detailed information. [9; 60]



## 6 Experimental Analysis

As outlined in the introduction, the thesis's primary goal is to provide more detailed information on the impacts of specific concrete mix design changes on compressive strength development and get better insights into deviations and influences on the accuracy which can occur in practice. In particular, to answer the questions in Chapter 1.2.

The research focuses on **standard concrete components** usually available at the ordinary batching plant, especially in the Czech Republic and central Europe. All materials used in the lab experiments were sampled at regular cement production or concrete plants (such as cement, sand, additions, and admixtures), excluding the standard sand used as a reference. The concrete tests were performed at the concrete plant or even on the construction site. The aim was to collect the **results from practice** to provide relevant information for the concrete industry. That is the crucial distinction compared to most other theses in this field, usually done in the laboratory.

### 6.1 Procedure

The research was divided into six phases, which allowed for step-by-step investigation. The tests started in the laboratory environment, which provided more precise results with fewer deviations but more limited usability in practice. Then, the investigation continued on the concrete plant, which already offers valid practical results. One of the last phases took place directly on the construction site, the closest to the actual use of concrete. Learning from the previous phase was always utilized during the detailed planning of subsequent steps.

### 6.2 Procedure of Analysis

Individual phases are briefly presented below. A more detailed description is in the following chapters, where every chapter introduces one phase and its results.

#### 1) Isothermal calorimetry of cement

- Target: More detailed input information about cement types used in further experiments
- Standard: EN 196-11
- Duration: 04/2021 – 06/2021 and 10/2022 – 12/2022
- Place: Laboratory at CTU Prague, department of material engineering and chemistry

#### 2) Test of cement mortar

- Target: Hands-on experience for concrete tests
- Standards: EN 196-1, NEN 5970
- Duration: 06/2021 – 09/2021



- Place: Laboratory at CTU Prague, department of concrete and masonry structures
- 3) Calibration of different concrete mixes**
- Target: Overview of influences of different changes in a concrete mix design under actual conditions, experiencing the deviations in the practice
  - Standards: EN 206+A2, EN 12350, EN 12390, NEN 5970
  - Duration: 09/2021 – 10/2021
  - Place: Concrete plant TBG Metrostav, Prague
- 4) Regular validation on the construction site**
- Target: Information on possible deviations on the construction site
  - Standards: EN 12350, EN 12390, NEN 5970
  - Duration: 11/2021 – 05/2022
  - Place: Residential project VIVUS Golf Park, Prague
- 5) Water-cement ratio test**
- Target: Quantification of the influence of extra added water
  - Standards: EN 206+A2, EN 12350, EN 12390, NEN 5970
  - Duration: 05/2022 – 06/2022
  - Place: Concrete plant TBG Metrostav, Prague
- 6) Determination of C-values**
- Target: Accuracy improvement in gained results
  - Standard: NEN 5970
  - Duration: 09/2022 – 10/2022
  - Place: Concrete laboratory Concrefy, Netherlands

The pictures below provide a preview of the executed experimental parts. [7; 31; 32; 35]



Figure 32 - Isothermal calorimetry test, cement mortar tests, calibrations at concrete plant [photo: author]



Figure 33 - Validations on the job site, water-cement ratio test, determination of C-value [photo: author]

## 6.3 Methodology

During the execution of the experiments, close attention was paid to compliance with standards and the reduction of deviations related to unqualified and inconsistent execution of laboratory tests. Cement and cement mortar tests were performed according to EN 196-11 and EN 196-1. Concrete tests complied with EN 206+A2, a group of standards for testing fresh concrete EN 12350 and hardened concrete EN 12390. Utilization of the maturity method followed the requirements in Dutch NEN 5970.

The author executed the tests for two main reasons exclusively. The first goal was to minimise the variations by having just one laboratory technician = thesis author. The second aim was to get more hands-on experience and skills, which is much more enriching than just receiving the results without involvement.

## 6.4 Extent of research

The research started in the spring of 2020 by searching for a suitable topic and preparing a concept. During the early spring of 2021, materials for laboratory tests were arranged and collected. The planned experiments and continuous evaluation took place from 04/2021 to 12/2022. The research was funded within the "Student grant competition of Czech Technical University in Prague" by the project SGS21/041/OHK1/1T/11 and SGS22/034/OHK1/1T/11.

The extent of research could be indicated by tested mortar and concrete samples. The compressive strength of almost 650 halves of the cement prisms and nearly 250 concrete cubes were tested.



## 7 Isothermal Calorimetry of Cement

This chapter describes the first phase of the experimental part, where the target was to get more detailed input information about used cement types. The aim was to choose cement types commonly available on the concrete plant and cover different percentages of clinker substitutions. The following cement types were tested and further used in the following phases:

- CEM I 42,5 R (cement plant: Radotín)
- CEM I 42,5 R (cement plant: Mokra)
- CEM II/B-S 32,5 R (cement plant: Radotín)
- CEM II/B-S 32,5 R (cement plant: Mokra)
- CEM III/B 32,5 L (cement plant: Mokra)

The combination of CEM II/B-S 32,5 R (83,3%) and fly ash (16,7%) was also tested because this cement and fly ash mix was commonly used in tested concrete mixes in the following phases of the research. The isothermal calorimetry tests were performed in two stages (spring 2021 and autumn 2022) with different batches of cement and different temperatures during the test. Initially, the second testing was not planned. This idea came up during the test of the C-value (Chapter 12). The tests followed EN 196-11's recommended procedure, described in Chapter 2.4.1. The only exception is the temperature during the first testing stage, 25°C instead of the recommended 20°C. At that time, the test temperature of 25°C had to be used because of other samples which were tested in parallel. This recent restriction now helps clearly show the influence of temperature on the hydration reaction. [31]

### 7.1 Results

Table 4 summarises the results of the calorimetry tests. Each value represents the average of two tests, as the standard requires. The presented heat of hydration was measured seven days after mixing cement with water acc. EN 196-11. [31]

The development of hydration heat is presented and compared in the following figures. For better visibility of all curves, the duration of the development is shortened from seven days to five days because heat flow during the last two days is very low and insignificant for comparison. The scale of heat flow is from zero to 4 mW/g to increase the visibility of the main hydration peak. The first peak, which occurred within the first minutes after mixing, is shown only until 4 mW/g for two reasons. Values measured during the first hydration peak could deviate a lot, and those values are not crucial for the subsequent investigation. Since the difference in hydration heat development of the same cement types from two different productions (Radotín, Mokra) are minor, only curves from Radotín are presented, including the CEM III/B 32,5 L, which is produced in Mokra only.



Table 4 - Results of isothermal calorimetry tests - overview

Cement type (Plant)	Supplementary cementitious materials	Batching	Temperature [°C]	The heat of hydration [J/g]	Main hydration peak [mW/g]
CEM I 42,5 R (Radotín)	-	04/2021	25	<b>323,5</b>	3,80
CEM I 42,5 R (Mokrá)	-	04/2021	25	<b>298,9</b>	3,55
CEM II/B-S 32,5 R (Radotín)	-	04/2021	25	<b>259,2</b>	3,03
CEM II/B-S 32,5 R (Mokrá)	-	04/2021	25	<b>257,5</b>	2,71
CEM III/B 32,5 L (Mokrá)	-	04/2021	25	<b>195,5</b>	1,92
CEM I 42,5 R (Radotín)	-	08/2022	20	<b>300,4</b>	2,42
CEM II/B-S 32,5 R (Radotín)	-	08/2022	20	<b>227,9</b>	1,80
CEM III/B 32,5 L (Mokrá)	-	08/2022	20	<b>184,0</b>	1,45
CEM II/B-S 32,5 R (Radotín)	fly ash (16,7%)	08/2022	20	<b>201,0</b>	1,47

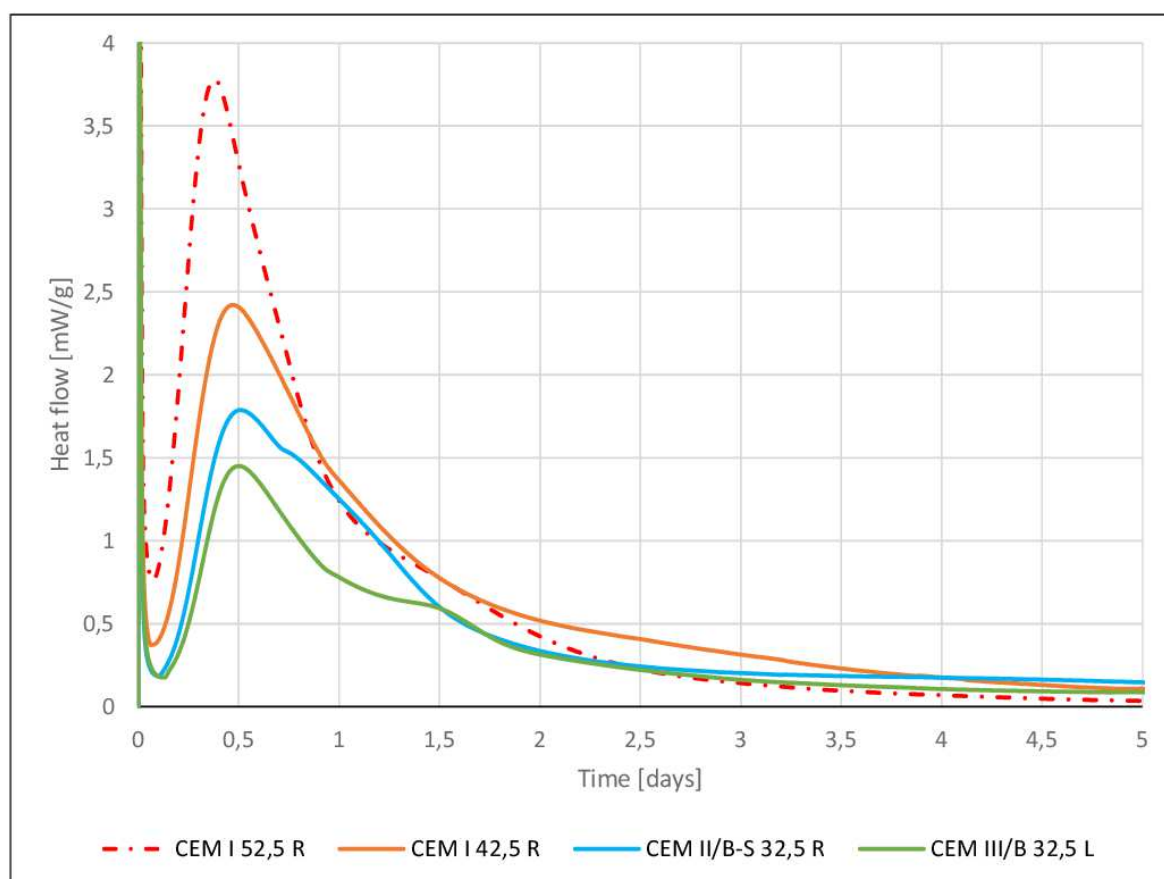

Figure 34 - Heat of hydration of different cement types, tested at 20°C

Figure 34 compares the hydration heat development of four cement types. CEM I 52,5 R was tested for another project and was added to the comparison as a reference for the cement type previously used in the precast industry. (Note of the author: This cement



type is currently being substituted with CEM II/A-S 52,5 R or CEM II/A-LL 52,5 R.) Presented cement types contain the following amount of clinker (without calcium sulfate) acc. EN 197-1. [16]

- CEM I 42,5 R and 52,5 R >95% of clinker
- CEM II/B-S 32,5 R 65 – 79% of clinker
- CEM III/B 32,5 L 20 – 34% of clinker

Differences between the hydration heat are significant (Figure 34 and Table 4 – lower part) from the main hydration peak and total hydration heat point of view.

Figure 35 shows the comparison of hydration heat development at testing temperatures of 20°C and 25°C. Results confirm a considerable influence of temperature on the development of hydration heat. The main hydration peak of all types of cement is significantly higher at 25°C, and the heat flow decreases faster. The increases influenced by temperature are presented in Table 5. For example, the maximum heat flow of CEM II/B-S 32,5 R is 68% more at 25°C than at 20°C, and the released heat of hydration during seven days is 14% higher.

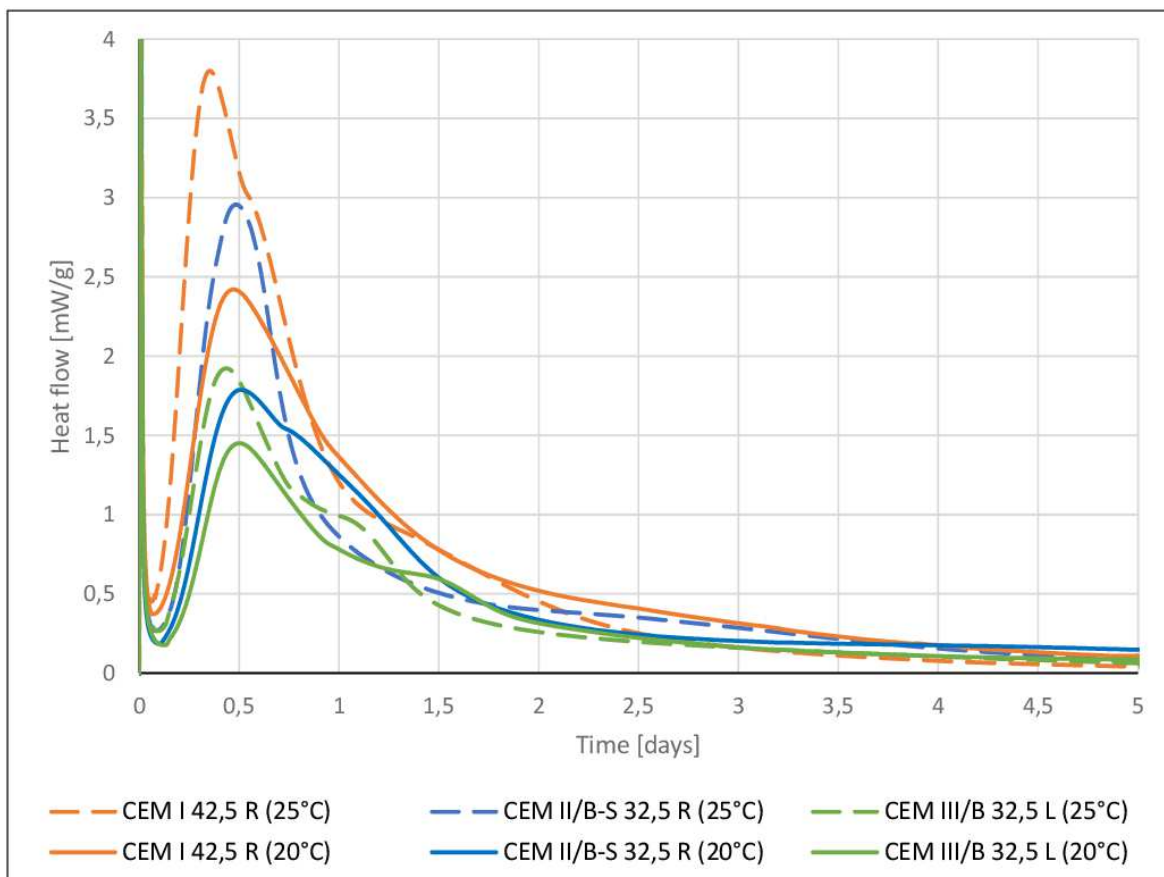

Figure 35 - Heat of hydration of different cement types at 20°C and 25°C

Tests at 25°C and 20°C were not performed using the same samples. The first test samples (25°C test) were batched at the cement plant in April 2021, and the second (20°C test) in August 2022. Because of that, certain deviations in the results could occur.





Table 5 - Comparison of hydration heat development at 20°C and 25°C

Cement type (Plant)	Heat of hydration [J/g]		Increase [%]	Main hydration peak [mW/g]		Increase [%]
	20°C	25°C		20°C	25°C	
CEM I 42,5 R (Radotín)	300,4	323,5	<b>8</b>	2,42	3,80	<b>57</b>
CEM II/B-S 32,5 R (Radotín)	227,9	259,2	<b>14</b>	1,80	3,03	<b>68</b>
CEM III/B 32,5 L (Mokrá)	184,0	195,5	<b>6</b>	1,45	1,92	<b>32</b>

Figure 36 shows the hydration heat of CEM II/B-S 32,5 R and fly ash. As mentioned, this combination is often used in concrete mix designs in the research phases, which took place at the concrete plant and on the construction site. Because of its frequent use, the test of it was performed as well. Added fly ash decreased the main hydration peak of CEM II/B-S 32,5 R and reduced the value of maximum heat flow to the level of CEM III/B 32,5 L. Released hydration heat is reduced by fly ash to 88% in comparison with 100% CEM II/B-S 32,5 R.

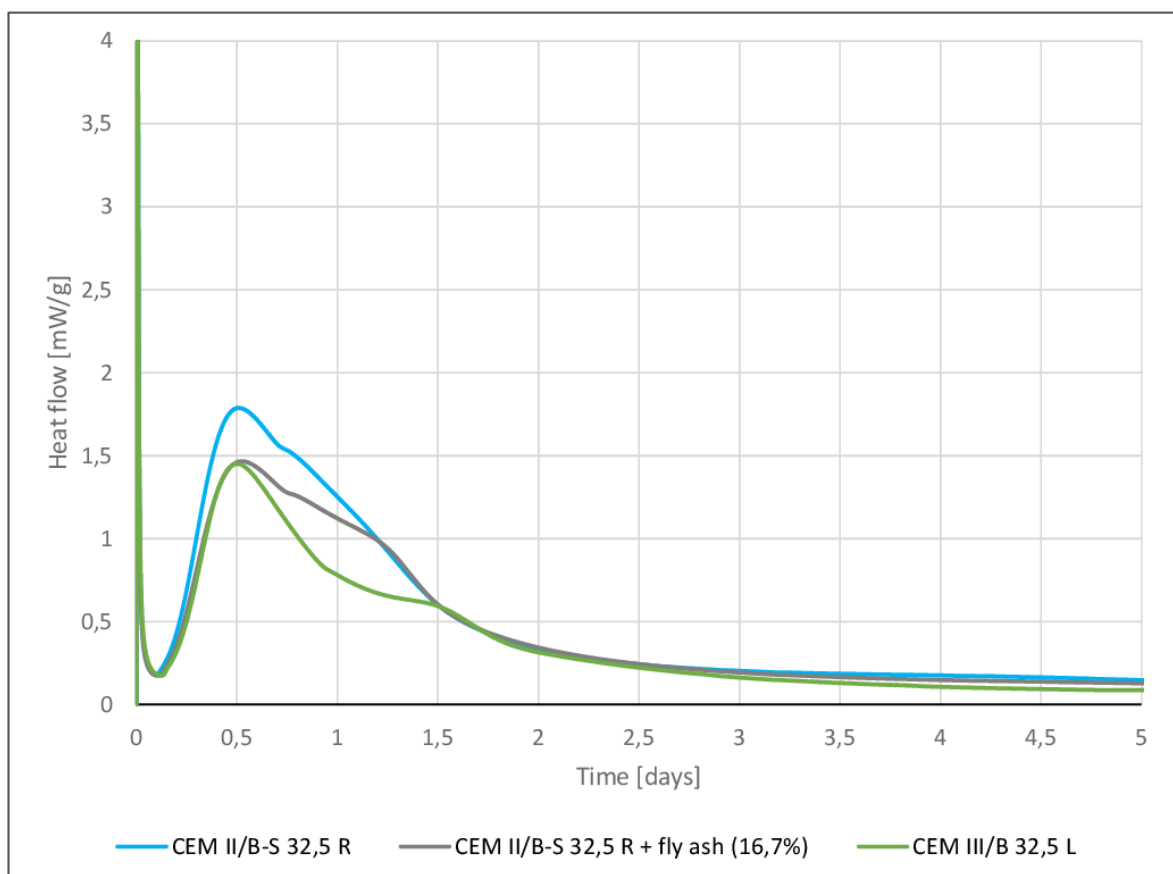

Figure 36 - Heat of hydration of CEM II/B-S 32,5 R + fly ash, tested at 20°C



## **7.2 Summary**

The isothermal conduction calorimetry method is an exact test which provides detailed information on hydration heat development. The development of hydration heat flow allows a comparison of the hydration of different cement types or cement types mixed with supplementary cementitious materials.

In total, 18 samples of cement were tested, and the duration of all tests was seven days. The test's results provided valuable information about the hydration of tested cement types and confirmed the significant influence of temperature on hydration. That gave the author helpful input information and an understanding of tested materials.



## 8 Cement Mortar Tests in Laboratory

As already mentioned, one of the main goals of the thesis is to provide a detailed overview of the effect of concrete mix design changes on compressive strength development, which is in the case of the maturity method expressed as a calibration curve. This research phase aims to investigate the cement mortar samples and get good basics and hands-on experiences for further investigation with ready-mix concrete. This research phase took place in the laboratory, which reduced the number of deviations and provided proper preparation for a less accurate research environment (e.g. concrete plant) in the following phases. Tests were performed deliberately with cement mortar samples due to the possibility of creating a huge amount of testing samples with a small amount of material. Commonly used concrete testing samples (150 mm cube) were substituted for cement mortar prisms 160 x 40 x 40 mm. Experimental work of this phase was executed in the summer of 2021.

Investigated changes in the cement mortar mix design include using different types of cement from various sources, amount of cement, water-cement ratios, fine aggregates from various sources, admixtures and additions. Besides the mentioned comparison results, the experimental analysis also presents information about accuracy and deviations. Deviations were investigated by a repeated calibration curve determination after a specific time.

### 8.1 Methodology

Before the execution of laboratory tests, a plan of sixteen cement mortar mix designs was produced (Table 6). Cement mortar mix designs were based on the standard cement mortar composition (acc. EN 196-1): 1350 g of CEN standard sand, 450 g of cement, and 225 g of water. Standard cement mortar composition was used for all five cement types. Then, cement mortar mix designs using CEM II/B-S 32,5 R (Radotín) with different changes were designed. Changes were the following: the different amounts of cement, the different water-cement ratio in combination with added superplasticizer, the replacement of CEN standard sand by sand from three different quarries, the addition of setting accelerator, substitution of a certain amount of cement for fly ash or limestone. The following materials were used in the experiments: [32]

- Cement
  - CEM I 42,5 R (Radotín 04/2021 and Mokra 04/2021)
  - CEM II/B-S 32,5 R (Radotín 04/2021, 07/2021 and Mokra 04/2021)
  - CEM III/B 32,5 L (Mokra 04/2021)
- Fine aggregates
  - CEN standard sand (Doksy 04/2021)
  - Sand "A" 0-4 mm (western part of Czech Republic 03/2021)
  - Sand "B" 0-4 mm (northern part of Czech Republic 04/2021, 07/2021)
  - Sand "C" 0-4 mm (northern part of Czech Republic 04/2021, 07/2021)



- Tap water
- Admixtures
  - Superplasticizer Sika Viscocrete 1035
  - Setting accelerator Chryso XEL 650
- Addition
  - Fly ash
  - Limestone

Before collecting all materials, the subsequent phases of research were considered, and materials available at the concrete plant where the research afterwards took place were included. All cement types mentioned above were tested by isothermal calorimetry in previous phases. The source of different sands is not mentioned in the thesis and is substituted by letters A, B, and C, as agreed with concrete suppliers, where the sand was picked up. However, some basic properties of those sands are presented.

### 8.1.1 Cement mortar composition

A detailed description of all cement mortar mix design is stated in Table 6. All mix designs were designed based on the volume equation, similar to the concrete mix design acc. equation (2). Initially, the required volume was 0,88 litres as the volume of standard cement mortar acc. EN 196-1. Afterwards, the amount of ingredients was slightly changed in direct proportion to reach 1350 g of CEN standard sand, which is precisely one bag. All the mix designs were tailored to that amount because the Standard sand can't be easily mixed to reach an even distribution of different grains if all aggregate sizes are already mixed. The standard sand was already available in plastic bags containing precisely the amount for one usual cement mortar mix (Figure 37); therefore, the above-described procedure was introduced. [32]

The mix design with the used superplasticizer (WC-04) was designed to reach a similar consistency as the reference mix design (CT-03). The mix designs with substituted CEN standard sand for sand from the concrete plant (SA-01, 03, 04) were designed to achieve similar consistency as the reference mix design (CT-03); therefore, more water is added. All consistency adaptations were based on the results of the flow cone test, which was included in the whole testing procedure.



Figure 37 - Plastic bag of standard sand in accordance with EN 196-1 [photo: author]

Table 6 - Description of cement mortar mix designs

Phase	Mix design	Cement mortar composition					Notes
		Sand [g]	Cement [g]	Water [g]	Admixture [g]	Addition [g]	
Cement type	CT-01	Standard	CEM I 42,5 R (R)	Water	-	-	acc. EN 196-1
		1350	450	225	0	0	
	CT-02	Standard	CEM I 42,5 R (M)	Water	-	-	acc. EN 196-1
		1350	450	225	0	0	
	CT-03	Standard	CEM II/B-S 32,5 R (R)	Water	-	-	acc. EN 196-1 (reference)
		1350	450	225	0	0	
	CT-04	Standard	CEM II/B-S 32,5 R (M)	Water	-	-	acc. EN 196-1
		1350	450	225	0	0	
	CT-05	Standard	CEM III 32,5 L (M)	Water	-	-	acc. EN 196-1
		1350	450	225	0	0	
Cement amount	CA-02	Standard	CEM II/B-S 32,5 R (R)	Water	-	-	cement amount +50 g
		1350	544	272	0	0	
	CA-03	Standard	CEM II/B-S 32,5 R (R)	Water	-	-	cement amount -50 g
		1350	370	185	0	0	
Water / cement ratio	WC-01	Standard	CEM II/B-S 32,5 R (R)	Water	-	-	w/c = 0,55
		1350	471	259	0	0	
	WC-02	Standard	CEM II/B-S 32,5 R (R)	Water	-	-	w/c = 0,45
		1350	431	194	0	0	
	WC-04	Standard	CEM II/B-S 32,5 R (R)	Water	Superplastic.	-	w/c ≈ 0,45 + superplastic.
		1350	431	191	3,0	0	
Fine aggregates (sand)	SA-01	Sand A	CEM II/B-S 32,5 R (R)	Water	-	-	sand from concrete plant
		1350	450	280	0	0	
	SA-03	Sand B	CEM II/B-S 32,5 R (R)	Water	-	-	sand from concrete plant
		1350	450	250	0	0	
	SA-04	Sand C	CEM II/B-S 32,5 R (R)	Water	-	-	sand from concrete plant
		1350	450	250	0	0	
Accelerator	AC-01	Standard	CEM II/B-S 32,5 R (R)	Water	Accelerator	-	setting accelerator 1,1%
		1350	450	220,0	5,0	0	
Fly ash	FA-01	Standard	CEM II/B-S 32,5 R (R)	Water	-	Fly ash	substitution - fly ash
		1350	368	230	0	92	
Limestone	LS-01	Standard	CEM II/B-S 32,5 R (R)	Water	-	Limestone	substitution - limestone
		1350	365	228	0	91	
Notes: The cement plant is defined by letters in brackets: (R) - Radotín, (M) - Mokrá. Description of sand "Standard" stands for CEM standard sand. Mix design CT-03 is considered a reference mix design. All changes in comparison to mix design acc. EN 196-1 are marked in red. Cement mortars are designed based on the volume equation and proportionally adapted to one bag of standard sand (1350 g).							

## 8.2 Procedure

Twelve prisms were produced for each of the sixteen mentioned mix designs (with a few exceptions). Six prisms were used to determine the calibration curve, and another three were used for the 28-day compressive strength test acc. EN 196-1. The remaining three prisms were produced approximately a month later and tested as validation samples of a previously determined calibration curve. The number of test samples per mix design and their relation to tests is summarized in Figure 38. The calibration curves of specific mix designs were determined several times for validating calibration curves (e.g. CT-02, CT-03, or CT-04). [32]

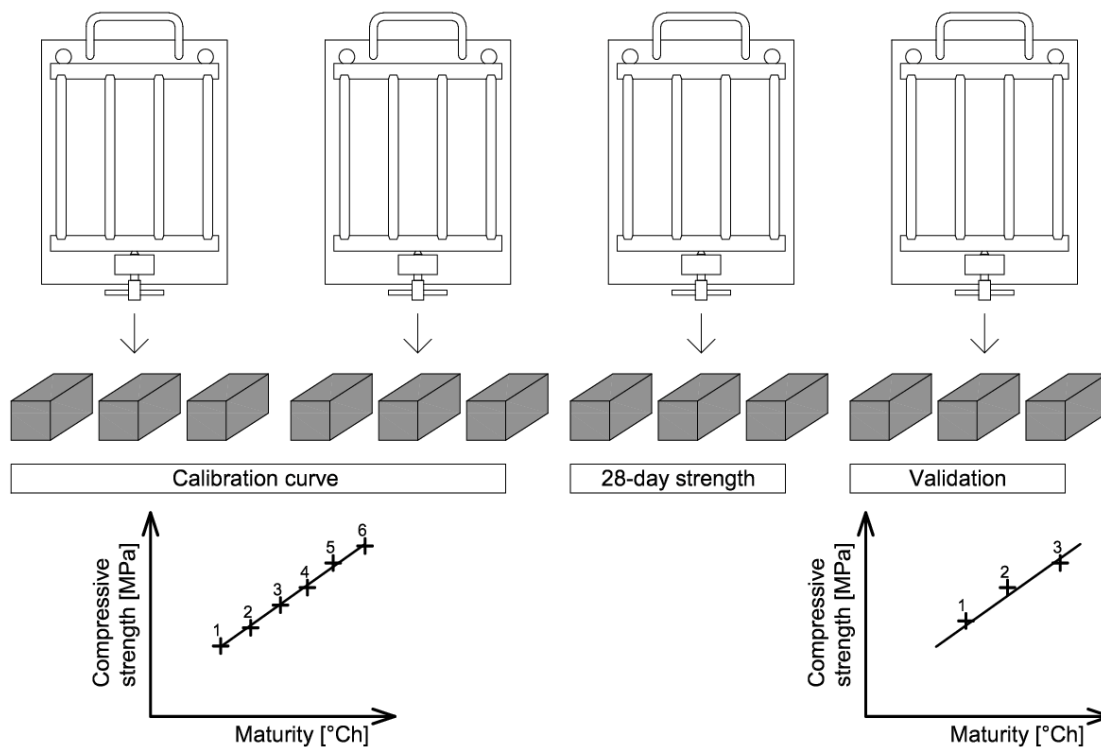

Figure 38 - Amount of test samples per mortar mix design and related tests [scheme: author]

The procedure of sampling, curing and testing was following: [32; 61]

- Cement mortar was mixed in compliance with EN 196-1 using a suitable mortar mixer (Figure 39 - left).
- Flow cone test of fresh cement mortar was performed in accordance with EN 1015-3 (Figure 39 - middle).
- Samples were created and compacted following the procedure in EN 196-1. The only exception regarding the standard requirements was a vibrating table, which was used instead of the recommended jolting apparatus (Figure 39 - right).
- Prisms were cured in the following conditions:
  - During the first 24 hours, mould with the prisms was in the lab conditions. Since the curing chamber was unavailable, appropriate moisture

conditions were ensured by wrapping the mould. The upper part of the mould was covered with cling film to prevent water evaporation. A wet sponge blanket was put on the cling film as a water source, and the whole mould was properly wrapped into the cling film (Figure 40 - left). The ambient temperature in the lab was continuously monitored and recorded. The sample's temperature was assumed to be very close to the ambient temperature because all ingredients were stored in the laboratory before mixing, and steel mould could conduct hydration heat away quickly.

- After approximately 24 hours, prisms were demoulded, labelled and put into the water bath, where the temperature was continuously recorded. The sample temperature was assumed to be similar to the water temperature.
- A sample was removed from the bath and weighed at the defined testing time, and its dimensions were measured. Flexural strength was determined acc. EN 196-1 (Figure 40 - middle).
- Two halves, which remained after the flexural strength test, were used for the compressive strength test following EN 196-1 (Figure 40 - right). The average value of the two tested halves was calculated.
- The maturity of the cement mortar prism at the time of testing was calculated based on a measured temperature of curing conditions. One point for future calibration (regression) line consists of the average tested compressive strength value at the y-axis and the calculated maturity value at the x-axis.

The abovementioned procedure was usually performed four times per mix design because twelve samples were needed, as illustrated in Figure 38. Testing times for calibration and validation were planned according to the calibration curve range, which was focused on the upper part of early-age strength development up to 70% of 28-day compressive strength. Six calibration prisms of each mix design were tested one by one gradually. The same applied later for three validation samples. Most of the time, all early-age compressive strength tests were planned and performed between the 2<sup>nd</sup> day and the 7<sup>th</sup> day after the creation of samples.



Figure 39 - Mixing of cement mortar, flow cone test, sampling [photo: author]



The consistency of cement mortar was always tested only once per mix design while preparing 28-day prisms. Testing and evaluating the 28-day compressive strength test were more straightforward because all three samples were tested after 28 days, and no maturity calculations were necessary.



Figure 40 - Curing, flexural strength test, compressive strength test [photo: author]

## 8.3 Results

The results of experiments are expressed as regression lines of test results. Each point represents the average compressive strength value of two halves of one prism. Those regression lines describe the relationship between maturity and compressive strength. The regression line is always based on five or six results. Equations of the regression line are presented in the graphs, including the coefficient of determination, which expresses the prediction quality. The maturity value on the x-axis uses a logarithmic scale. Regression lines show differences in strength development between different mortar mix designs independently of mortar temperature (within a typical temperature range). Compressive strength could be calculated for various temperature profiles (as illustrated in Figure 42).

The standard cement mortar mix design with CEM II/B-S 32,5 R was chosen as reference one since this cement type was used for all performed adaptations of the standard mortar mix design. Its regression line is drawn in orange in all following graphs within this chapter.

Figure 41 compares five different mix designs:

- Standard cement mortar composition with CEM I 42,5 R (CT-01)
- Standard cement mortar composition with CEM II/B-S 32,5 R (CT-03)
- Standard cement mortar composition with CEM III/B 32,5 L (CT-05)
- Cement mortar with CEM II/B-S 32,5 R and reduced water-cement ratio by superplasticizer (WC-04)
- Cement mortar with CEM II/B-S 32,5 R and setting accelerator (AC-01)

It is evident that cement type strongly influences the compressive strength development of cement mortar. CEM I 42,5 R (red) is approximately 17 MPa faster than CEM II/B-S 32,5 R (orange), and CEM III/B 32,5 L (green) is about 8 MPa slower than





CEM II/B-S 32,5 R. Noticable effect provides an added setting accelerator (purple), which shifted the regression line by 3,0 - 3,5 MPa in comparison with standard mortar composition. Using superplasticiser and reduced water-cement ratio (light blue) considerably improves strength development by about 6 MPa compared to ordinary cement mortar.

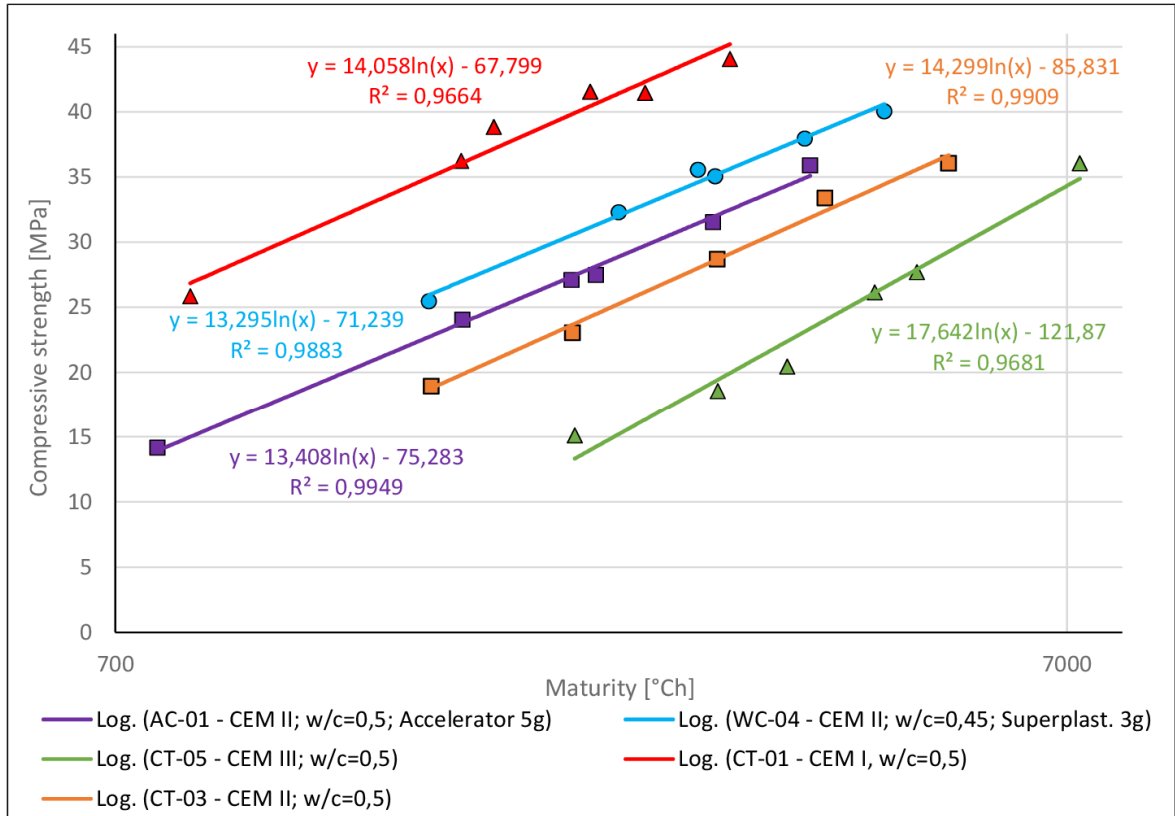

Figure 41 - Comparison of different cement types, use of superplasticizer and setting accelerator

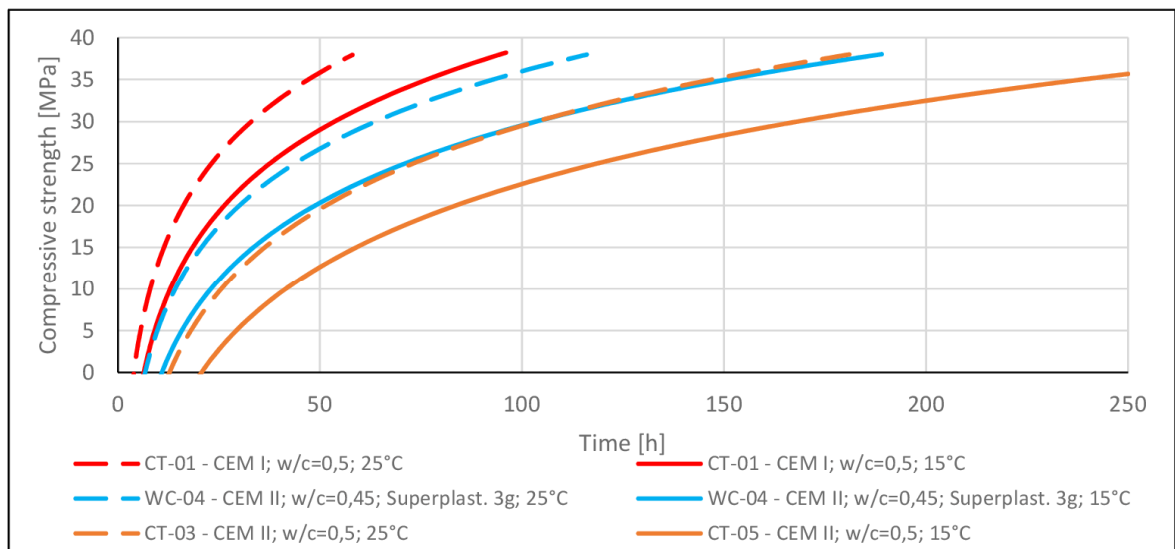

Figure 42 - Compressive strength development of selected mortar mix designs at mortar temperature of 15°C, 25°C



Figure 42 was included to illustrate a possible calculation of strength development for a temperature during hardening of, e.g. 15°C and 25°C, based on selected regression lines (CT-01, CT-03, WC-04) presented in Figure 41.

It shows the data in a more intelligible way. Compressive strength development, which is out of the tested range (e.g. CEM I below 25,9 MPa), needs to be considered as a rough estimation based on higher values, especially at a very early age below 5 MPa, where the development is simplified compared to the actual behaviour of concrete.

Figure 43 shows the difference between the cement types produced at the two cement plants in the Czech Republic – Radotín and Mokr. Regression lines of CEM I 42,5 R from both productions are almost identical (dark red and dark blue). On the contrary, the results of different CEM II/B-S 32,5 R samples deviate noticeably. Regression lines of two samples from Radotn batched at two different times show a difference of 2 MPa (orange and red). CEM II/B-S 32,5 R from Mokr (light blue) also behaves differently compared to Radotn’s samples, especially since the inclination of the line is different. However, the results above 25 MPa of all three samples are pretty close to each other.

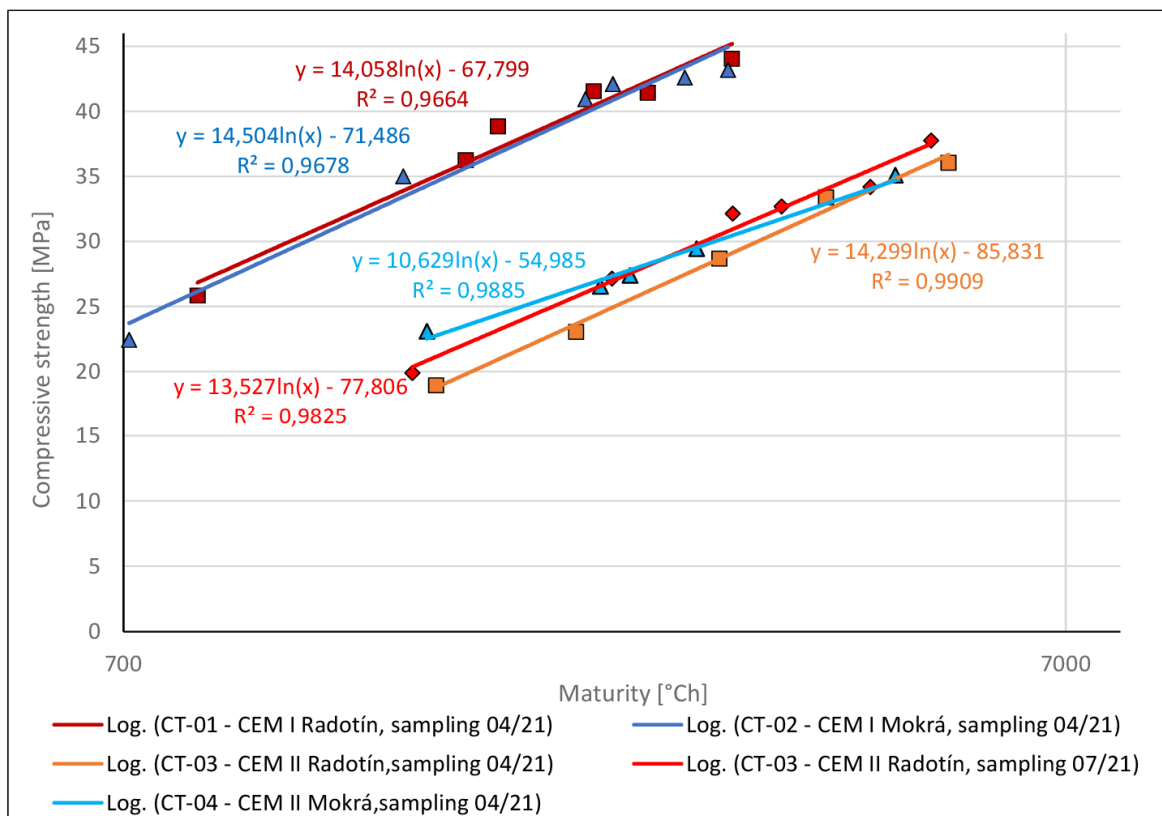

Figure 43 - Comparison of cements from two different cement plants

Figure 44 presents the results of repeated tests of identical cement batches. Cement mortar samples were made from the same batch of cement CEM I 42,5 R and CEM II/B-S 32,5 R. It means that cement was taken from the same bucket only the sec-



ond mortar mixing took place after a particular time interval - one month later. The results of both tests of CEM I 42,5 R correspond with each other very precisely. The results of two CEM II/B-S 32,5 R tests deviate from approximately 1,5 MPa, which is a satisfying result.

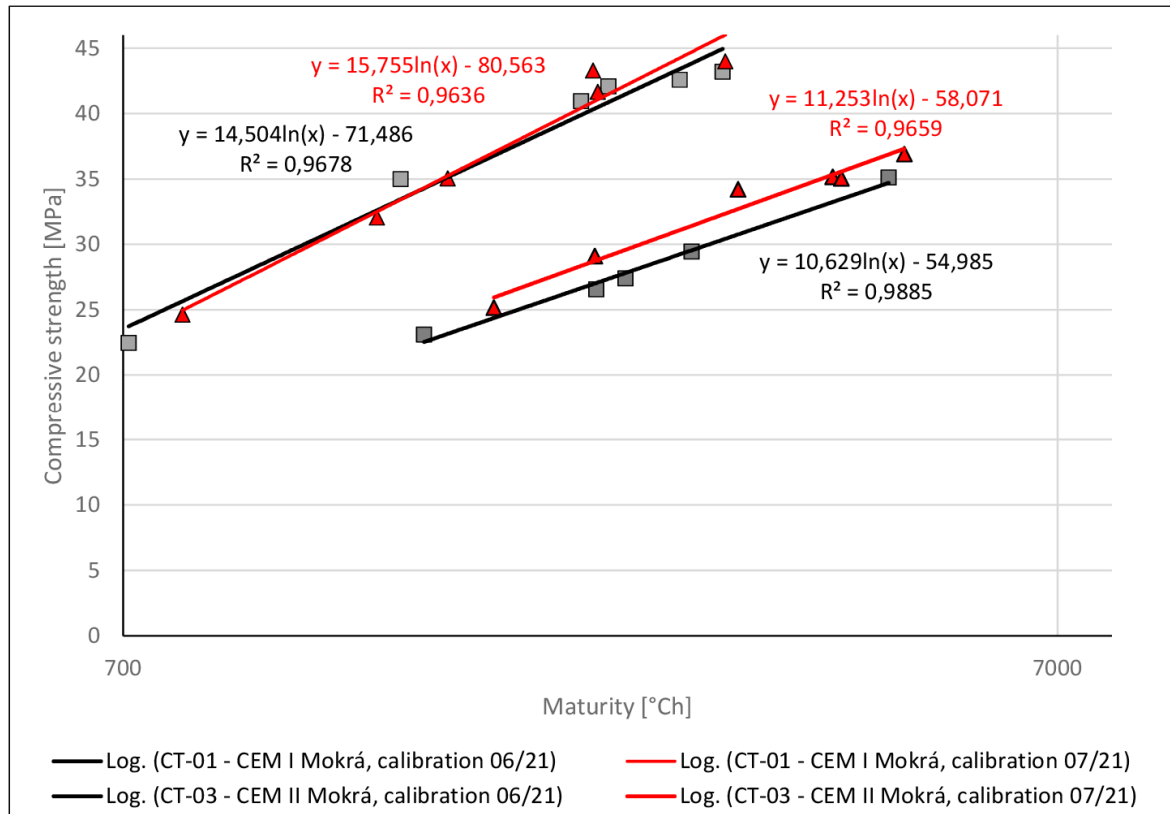

Figure 44 - Comparison of repeated calibration

Figure 45 shows the influence of increased and decreased cement amount and the use of concrete additions, particularly fly ash and limestone. Increased cement amount (red) improved slightly compressive strength development. On the contrary, reduced cement amount (green) slowed compressive strength development noticeably. The cement amount was changed as the only parameter to get the first hands-on. However, this adaption of a mix design should be done more systematically, similarly as it is presented later in Chapter 9.1, which deals with concrete mix designs. The consistency of mortar should be considered, which varied, in this case, a lot. The flow cone test of mortar with 500 g of cement reached a consistency of 22 cm, and the mortar with 400 g of cement achieved only 12 cm (Table 7).

Mortar mix designs, where 90 g of cement was replaced by addition, reached similar strength development as the mix design with reduced cement amount. Compared to fly ash (black), a mix design with limestone (grey) performed slightly better results (approx. + 1,5 MPa).

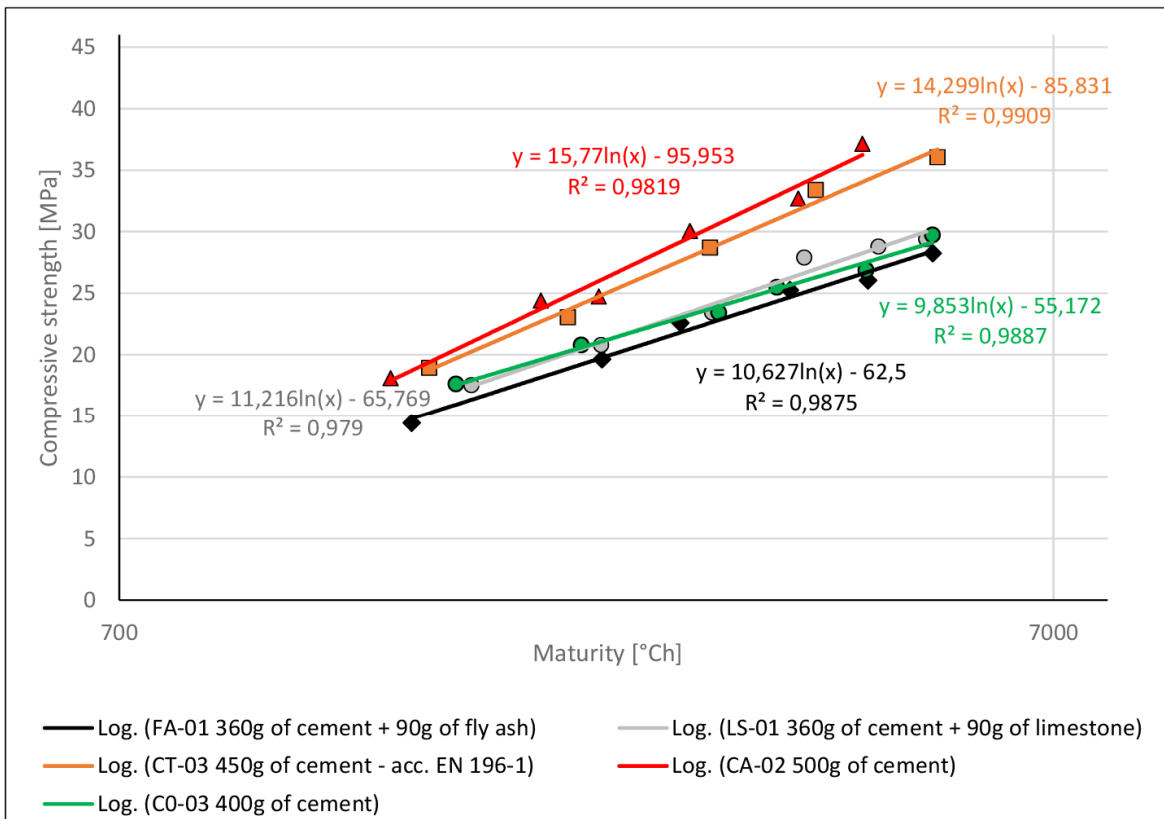

Figure 45 - Comparison of different cement amount and use of additions

Figure 46 presents an influence of the water-cement ratio and superplasticizer. The regression lines of mix designs with reduced and increased water-cement ratios consist of three results only because the workability of the mortar was not optimal and valuable for practice. However, it was essential to include those two mix designs to get better insights into the topic and demonstrate the effect on compressive strength development, which is significant. The flow cone test of cement mortar with reduced water (grey) was 12,5 cm, and it was tough to compact the samples properly. Cement mortar with increased water (light blue) was too fluid, achieving a flow cone test result of 22,5 cm.

Additionally, bleeding of mortar was observed during the creation of the sample. The mix design with a superplasticizer is crucial for investigating this topic because it is a practical example where water is reduced, and consistency is kept with the help of a superplasticizer. The water-cement ratio was reduced from 0,5 to 0,45, which required 3,0 g of superplasticizer. The flow cone test result was 16 cm, equal to the reference mix design. The influence of those measures on compressive strength development is enormous, approximately + 6 MPa. By the way, that is also the reason why superplasticizer is used in almost all concrete mixes.

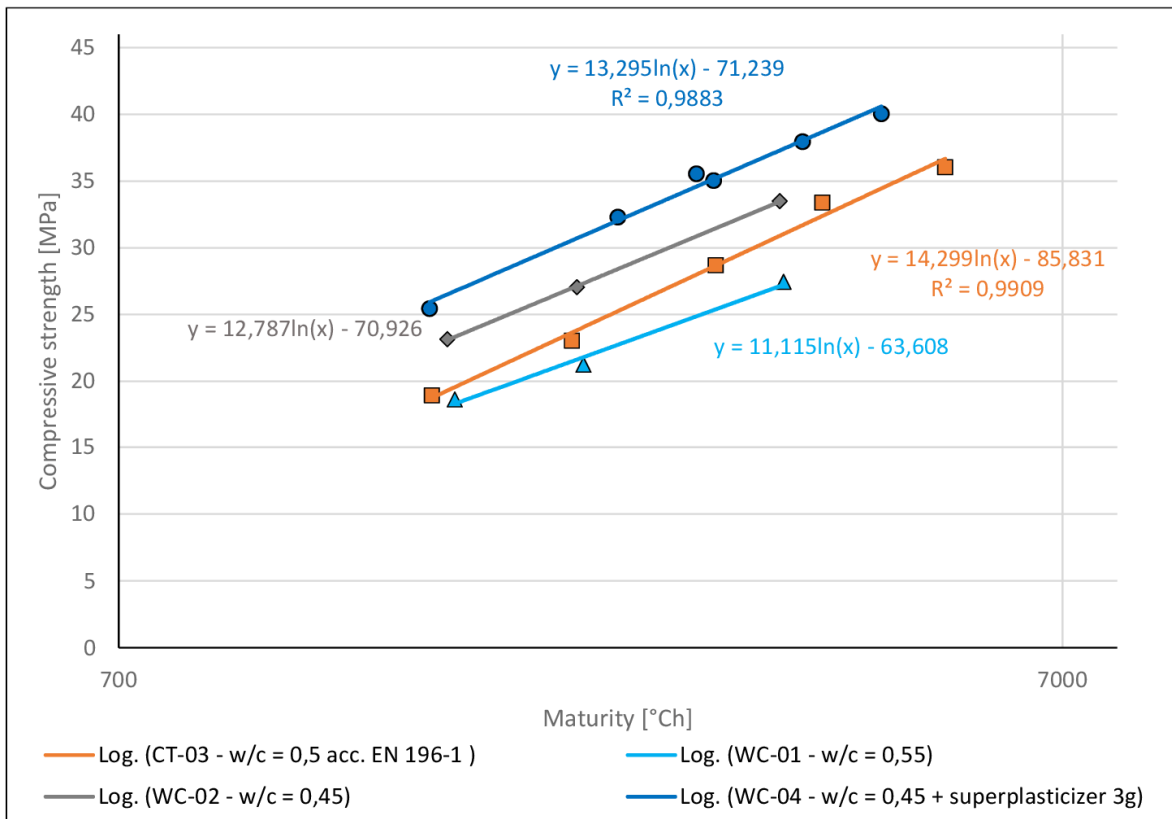

Figure 46 - Comparison of different water-cement ratio, use of superplasticizer

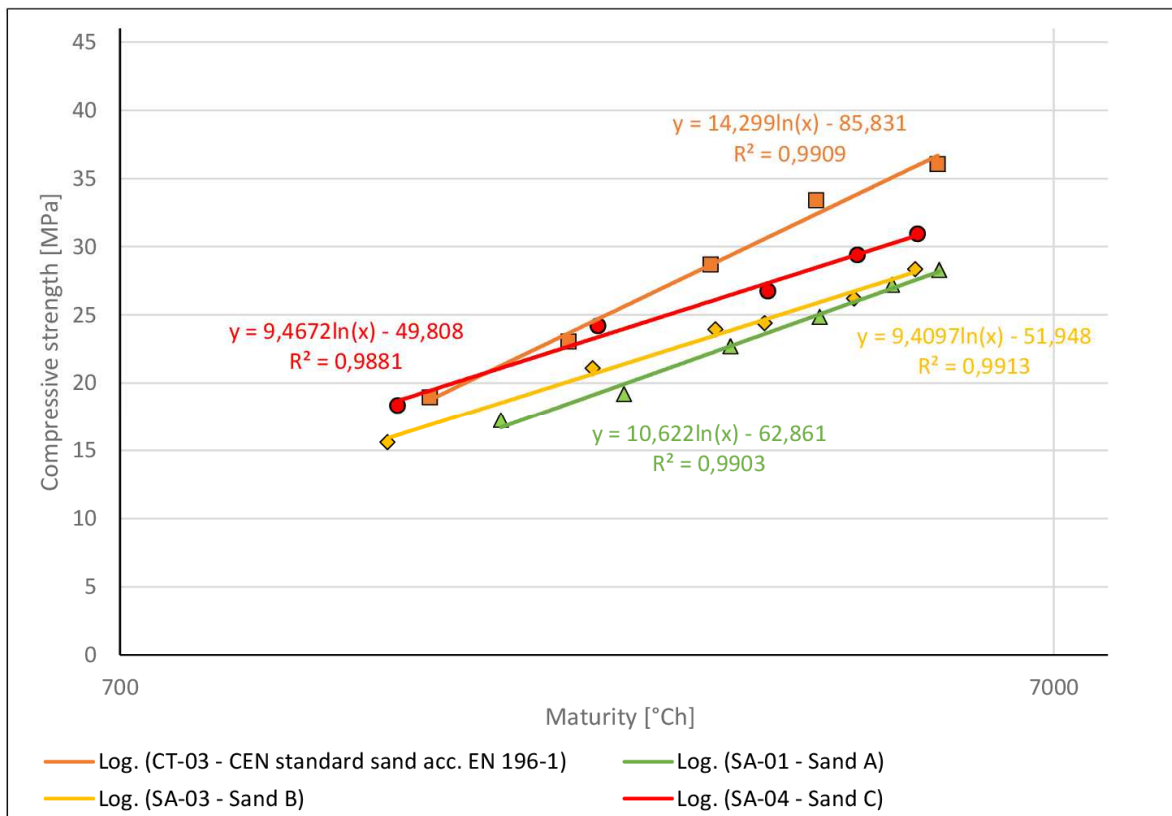

Figure 47 - Comparison of different type of sand

Figure 47 compares cement mortar mix designs with sand from different quarries. A reference mix design uses CEN standards sand (acc. EN-196-1), as all above-presented mix designs. The remaining three regression lines represent the results with mix designs using sand sampled at the concrete plant. One sample comes from a quarry in the western part of the Czech Republic, and two from the Northern region. The amount of water was slightly adapted to achieve consistency as with CEN standard sand. Used dosages of water are presented in Table 6. It is evident that the type of sand could significantly influence strength development. [32]

Figure 48 shows regression lines of three mix designs using real sand and includes the validation sample results. In the case of sand B and C, validation was performed from another batch of material sampled three months later. Initial results and validation results show a perfect correlation. The number of tested samples and batches is too small to provide a reliable conclusion about possible deviations. However, the aim of this investigation was to point out the importance of sand concerning compressive strength. Grain-size curves of used sand samples can be seen in Figure 50, and pictures of the samples in Figure 49.

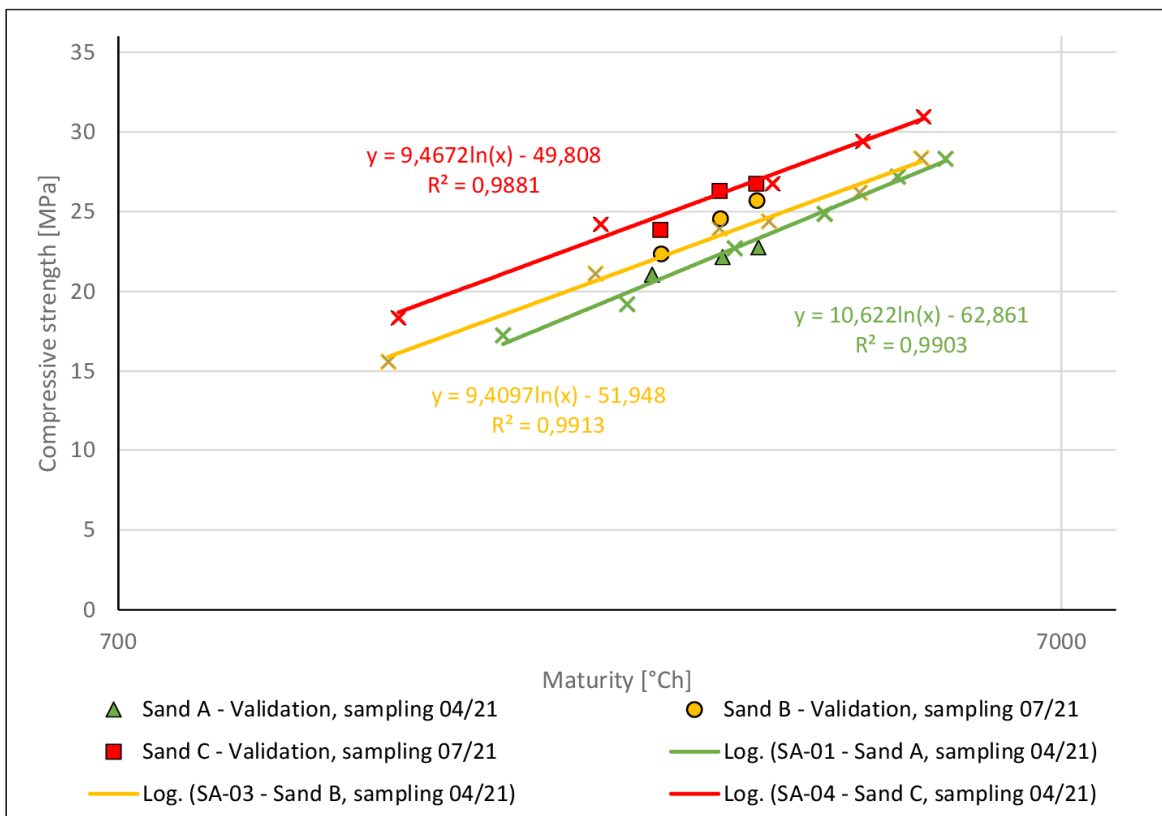

Figure 48 - Different type of sand, including validation samples



Figure 49 - Used types of sand in experiments

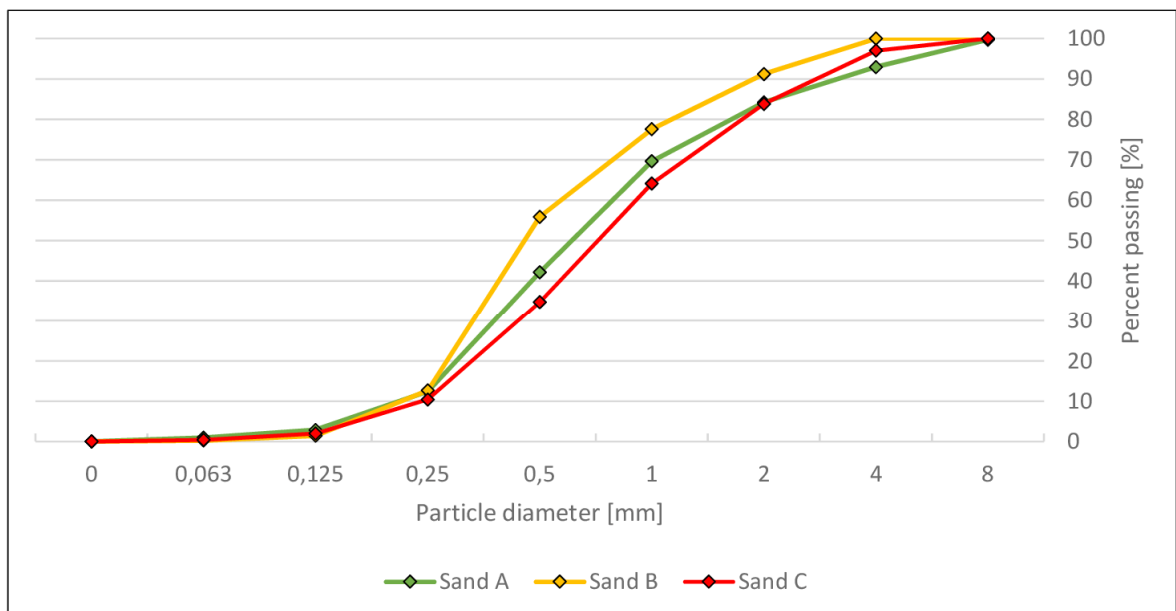

Figure 50 - Grain-size curve of used sand

Table 7 supplements the above-presented early-age strength data of mix designs with the consistency of fresh mortar and 28-day compressive strength values. The tested 28-day results are also compared with 28-day compressive strength from the cement data sheet.

Usually, the early-age results correspond very well with 28-day strength data. The only exception is mix design SA-03 and SA-04, where the value of 28-day compressive strength was expected to be much lower. Their early-age strength development is much slower than that of the reference mix design CT-03, but 28-day compressive strength is similar to CT-03, which is hardly explicable.



Table 7 - Consistency and 28-day compressive strength of cement mortar mix designs

Phase	Mix design	Used cement type (cement plant)	Consistency [cm]	28-day compressive strength [MPa]		
			Flow cone test	Result	Data sheet	Deviation
Cement type	CT-01	CEM I 42,5 R (Radotín)	17,0	56,6	59,7	3,1
	CT-02	CEM I 42,5 R (Mokrá)	18,0	62,8	59,1	-3,7
	CT-02-2		17,8	57,7	59,1	1,4
	CT-03	CEM II/B-S 32,5 R (Radotín)	15,8	53,5	47	-6,5
	CT-03-2		17,0	59,5	47	-12,5
	CT-04	CEM II/B-S 32,5 R (Mokrá)	17,8	64,1	50	-14,1
	CT-04-2		17,5	62,9	50	-12,9
CT-05	CEM III/B 32,5 L (Mokrá)	17,0	70,2	46,7	-23,5	
Cement amount	CA-02	CEM II/B-S 32,5 R (Radotín)	22,0	56,3	-	-
	CA-03		12,0	47,8	-	-
Water / ce- ment ratio	WC-01		22,3	-	-	-
	WC-02		12,5	-	-	-
	WC-04		15,8	59,2	-	-
Fine aggregates (sand)	SA-01		16,0	38,4	-	-
	SA-03		16,8	53,1	-	-
	SA-04		17,0	53,0	-	-
Accelerator	AC-01		17,5	50,3	-	-
Fly ash	FA-01		19,3	41,9	-	-
Limestone	LS-01		17,5	42,2	-	-

### 8.3.1 Validation and deviations

As mentioned in the procedure description, three prisms of each mix design were produced approximately a month after determining regression lines (calibration curves) and tested as validation samples of a previously determined calibration curve. The results of validation samples are presented in this chapter. The calculated deviation is the difference between calculated strength and tested strength. Calculated strength is determined by the maturity method de Vree considering the temperature development during hardening and previously experimentally determined calibration curve of mortar mix design. An example of the mentioned comparison is well illustrated in Figure 48.

Table 8 shows all individual results of validations, and Figure 51 presents a box plot of deviations between calculated and tested values. Table 8 also introduces the safety factor, which ensures the safety of estimated results by moving the regression line



downwards toward the x-axis. The safety factor was calculated following the recommended procedure in standard NEN 5970. The calculation of the safety factor is presented in Chapter 5.2.1. The deviations bigger than the safety factor and not fully covered by the safety factor are written in red. This happened in the case of only 7,7 % of tests. [7]

The average deviation of -0,8 MPa and the mean value of the deviation of -0,5 MPa indicate a slight systematic influence of the variations because the value of the two statistic values is not close to zero. The author of the thesis is unaware of any significant errors during the procedure, and the deflection of average and median values is considered acceptable.

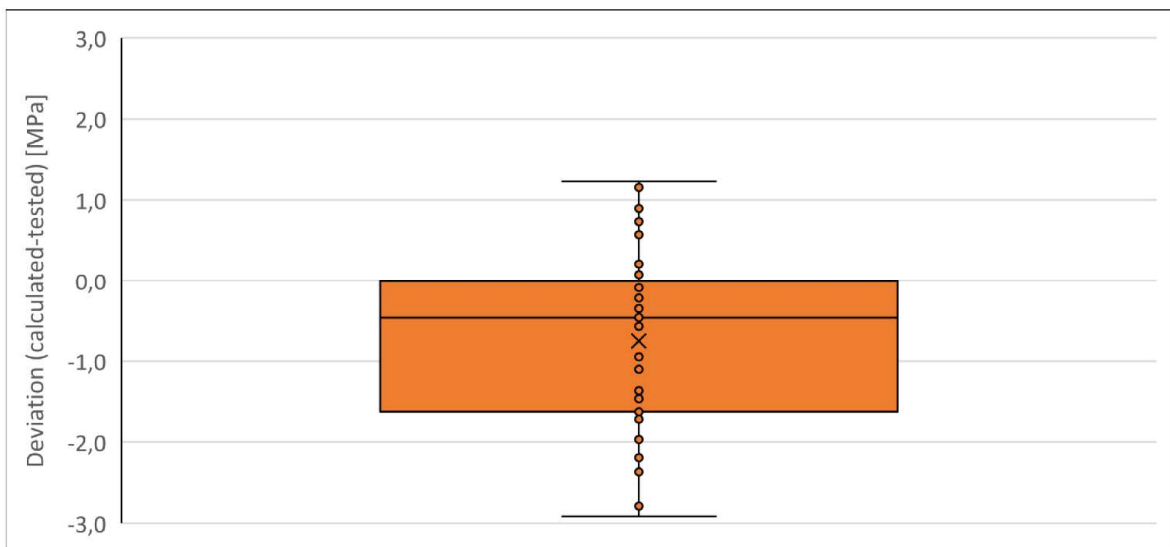

Figure 51 - Deviations of validation samples



Table 8 – Deviations of validation samples

Phase	Mix design	Maturity [°Ch]	Compressive strength (tested) [MPa]			Safety factor [MPa]
			Tested	Calculated	$\Delta$ (calculated - tested)	
Cement type	CT-01	1584	36,3	35,2	-1,1	3,1
		1308	32,1	32,0	-0,1	2,6
	CT-03	1557	35,1	34,5	-0,6	2,6
		2156	26,1	23,9	-2,2	2,6
		3103	32,1	29,1	-2,9	2,6
	CT-04	3957	35,4	32,6	-2,8	2,6
		2362	29,6	29,3	-0,2	2,3
		3059	32,7	32,2	-0,4	2,3
	CT-05	3902	37,4	35,0	-2,4	2,3
		2970	19,5	19,0	-0,5	1,8
		3794	22,7	23,4	0,7	1,8
	Cement amount	CA-02	4540	26,5	26,5	0,1
2718			29,1	28,7	-0,4	2,5
3185			32,2	31,3	-0,9	2,5
CA-03		3411	32,7	32,3	-0,3	2,5
		2557	22,2	22,1	0,0	2,5
		2965	24,0	23,6	-0,4	2,5
Water / cement ratio	WC-04	3250	26,1	24,5	-1,5	2,5
		2495	35,0	32,8	-2,2	2,8
		2963	37,2	35,0	-2,1	2,8
Fine aggregates (sand)	SA-01	3194	38,4	36,0	-2,3	2,8
		2578	21,1	20,6	-0,5	3,0
		3061	22,2	22,4	0,2	3,0
	SA-03	3341	22,8	23,3	0,6	3,0
		2636	22,4	22,2	-0,2	2,1
		3045	24,6	23,5	-1,0	2,1
	SA-04	3329	25,7	24,4	-1,3	2,1
		2630	23,9	24,7	0,9	2,3
		3039	26,3	26,1	-0,2	2,3
Accelerator	AC-01	3324	26,8	27,0	0,2	2,3
		2484	31,0	29,5	-1,5	2,5
		2951	32,3	31,8	-0,5	2,5
Fly ash	FA-01	3177	34,2	32,8	-1,4	2,5
		2567	22,5	20,8	-1,6	2,5
		2973	24,4	22,4	-2,0	2,5
Limestone	LS-01	3250	25,1	23,3	-1,7	2,5
		2556	20,9	22,1	1,2	2,8
		2961	23,1	23,8	0,7	2,8
		3244	23,7	24,8	1,2	2,8



## 8.4 Summary

Performed experimental analysis confirmed that the maturity method documents the changes in the mix design well, and the differences are clearly visible. From a linear regression point of view, maturity and strength correlate very well because the coefficient of determination  $R^2$  ranges from 0,96 to 0,99. All regression lines comprise six strength results (exceptionally five results), and the average coefficient of determination is  $R^2 = 0,98$ . Experiments confirmed a significant influence of cement type, cement amount and water-cement ratio on compressive strength development. Tests of different samples of sand from other quarries discovered a considerable impact of sand on early-age compressive strength and strength in general. The same types of cement from two various productions provided slightly different results. However, it is vital to emphasise that those two productions belong to one company. Based on the author's practical experience, the same cement types from different producers can evince different results.

Deviations observed during the validation testing are acceptable and prove the method's accuracy in laboratory conditions. Only a minority of results (3 of 39) exceeded the calculated safety factor.

In total, 432 halves of prisms were tested by the author. The cement mortar investigation provided a perfect basis for planning further concrete tests in the field, which will be much more crucial for the practice. In contrast to laboratory tests with relatively stable conditions, the next phase took place at the actual concrete plant for one and a half months, including possible changes which usually occur in practice.



## 9 Concrete calibrations

This experimental part follows the previous cement mortar tests. The main aim is to get an overview of the influences of different concrete mix design changes on compressive strength development under the actual conditions of a concrete plant. This research phase took place at the concrete plant TBG Metrostav in Prague. Most of the materials used at this concrete plant were used for cement mortar tests as well. Experiments were executed during September and October 2022.

Based on the result of cement mortar tests, the following adaptations of concrete mix designs were planned: different cement types, amount of cement, grain-size curve, the maximum size of aggregates, exchange of addition, and winter adaptations of a mix design.

In addition to the mentioned adaptations, deviations were investigated by repeatedly determining the calibration curve of a particular concrete mix design without any change five times during the whole experiment's duration.

### 9.1 Methodology

All investigated concrete mix designs come from the concrete supplier because the aim was to get relevant practical data directly from practice and avoid theoretical concrete mix designs, which do not comply with requirements in practice. All the testing was divided into five weeks. Three concrete mix designs were tested weekly – one reference and two with some adaptation. Eleven concrete mix designs were investigated, including the reference one. The specification of the reference concrete mix design is the following:

*C30/37 – X0, XC1-4, XD1-2, XF1, XA1 – CI 0,2 –  $D_{max} = 22 \text{ mm}$  – S4*

- *Cement type and amount: CEM II/B-S 32,5 R, 360 kg/m<sup>3</sup>*
- *Addition and amount: fly ash, 58 kg/m<sup>3</sup>*
- *Water-cement ratio: approx. 0,5*

The aim of the reference mix design was to get a benchmark for two concrete mix designs with executed changes every week and get a clear picture of the current situation on the concrete plant. Since the conditions on the concrete plant change daily (weather, materials), the reference concrete mix design allows comparison within a testing week with little deviations. Moreover, all five results of the reference concrete mix design from all five weeks provide information about possible variations within the period of one and a half months. The schedule of testing is presented below:

- 1<sup>st</sup> week (06.09. – 10.09.2023) three cement types
- 2<sup>nd</sup> week (13.09. – 17.09.2023) different cement amount
- 3<sup>rd</sup> week (20.09. – 24.09.2023) three grain-size curves
- 4<sup>th</sup> week (04.10. – 08.10.2023) additions (fly ash/limestone) and smaller  $D_{max}$
- 5<sup>th</sup> week (11.10. – 15.10.2023) winter mixes (shortened workability, accelerator)



Three concrete mixes with different cement types were tested during the first testing week. All three concrete mixes complied with strength class C30/37, but the first one was mixed with CEM I 42,5 R, the second with CEM II/B-S 32,5 R, and the third with CEM III/B 32,5 L. Some minor changes had to be implemented to reach suitable and comparable fresh concrete properties. The parameters of the concrete mix designs were not precisely the same but very similar. The mix design with the cement CEM II/B-S 32,5 R was selected as a reference.

During the second testing week, concrete mix designs with different cement amounts of CEM II/B-S 32,5 R were tested. Practically, it means testing the three different strength classes C25/30, C30/37 (reference mix design), and C35/45. Other parameters were slightly changed, especially the water-cement ratio and dosage of the superplasticizer. Everything was adapted in accordance with the fundamental principles of concrete technology and the economical usage of cement. It means mix designs with higher amounts of cement also had lower water-cement ratios. The aim was to reach similar fresh concrete properties.

The third testing week was dedicated to the grain-size curve. Besides the reference concrete mix design, one mix design with a finer and one with a coarser grain-size curve was tested. The main effort was again to keep most of the parameters very similar apart from the grain-size curve. Different grain-size curves were reached by mixing two types of sand. The coarse grain-size curve consists of one sand type. Standard and fine grain-size curves are combined from two sand types.

The fourth testing week combined two topics: the use of additions and the smaller maximum aggregate size. The reference mix design contains 58 kg/m<sup>3</sup> of fly ash. The second mix design uses limestone instead of fly ash, and the third uses a maximum aggregate size of  $D_{\max} = 16$  mm. Adapting the concrete mix design from  $D_{\max} = 22$  mm to  $D_{\max} = 16$  mm required other minor changes, especially an increase in cement amount (+10 kg/m<sup>3</sup>) and superplasticizer. However, the target was an alternative with a smaller aggregate size, which is usually used for complicated shapes and structural elements with tight reinforcement or more effortless pumping.

Three concrete mixes in the fifth testing week dealt with winter measures. Besides the reference concrete mix design, two winter-times mix designs were mixed – one with a shortened workability time and one with a setting accelerator.

A more detailed description of tested concrete mix designs is presented with the results (Chapter 9.3.1). Since the actual concrete mix designs were used for investigation, the author is not allowed to share all details about the mix design (such as dosage and type of admixtures and detailed grain-size curves of the mixes).



Figure 52 - Batching of the concrete before testing [photo: author]

## 9.2 Procedure

The testing procedure was the same for all tested concrete mixes and consisted of fresh concrete and compressive strength tests. The concrete mix was mixed at the concrete plant, batched into the concrete truck and a sample of approx. 150 l of concrete was poured from the truck into the plastic tank. Afterwards, the plastic tank was transported to the lab, just several meters from the batching plant. Before the beginning of the testing and in between the tests, concrete was homogenized by mixing with a shovel and trowel. The following tests were performed:

- The consistency of the concrete mix was determined by performing a **slump test** in compliance with EN 12350-2. [62]
- Determination of **density** was done according to EN 12350-6. A vessel from a pressure meter was filled with concrete and weighted. The vessel's volume of 8 l and dimensions comply with EN 12350-1 requirements. [45; 63]
- **Air content** was determined with a pressure meter according to principles stated in EN 12350-7. [64]
- The **amount of water** was calculated based on a dried fresh concrete sample. A weighted batch of approx. 4 kg of fresh concrete was placed on the metal sheet and dried for 48 hours in a drying chamber at 105°C. The dried sample was weighted, and the water content was calculated as a difference between the weight before and after the drying.
- Six standard concrete cubes (150x150x150 mm) were produced (acc. EN 12390-2) and placed into an insulated calibration box, where the temperature during hardening was measured. Concrete cubes were later tested in the laboratory following the **calibration** procedure described in NEN 5970 (Chapter 5.2.1). The target value for the calibration was 70% of the 28-day value. The aim was to get a range of calibration curve in compliance with the standard. It means a maximum  $\pm 8$  MPa from the target value. [7; 46]

- Three **validation** samples were prepared into standard new plastic moulds (acc. EN 12390-2), covered with a piece of plywood, and stored in the same temperature conditions. The temperature of one sample was monitored continuously. When the estimated strength reached the calibration range, all three samples representing one concrete mix were tested simultaneously, and the strength calculated based on the maturity method was compared with the tested strength, as described in Chapter 5.4. The target of the validation was to get more data about the accuracy of the method when the possible deviations were minimal because calibration and validation were performed from the same batch of concrete. The only difference was in the curing temperature of calibration and validation samples, which were monitored. [46]
- Additionally, to those tests performed by the thesis author, the concrete supplier tested **2-day, 7-day, 28-day, and 90-day strength** and **water-tightness**.



Figure 53 - Slump test, determination of density, air content [photo: R. Syka]



Figure 54 - Determination of w-c ratio, concrete calibration, validation samples [photo: author, R. Syka]

## 9.3 Results

The results of the tests mentioned above are presented in this chapter. First, the differences between the strength development of different concrete mix designs are shown. Calibration and validation results are expressed graphically in the figures. Later, the validation results, fresh concrete tests and standard compressive strength tests are presented in the tables. Repeated calibration of the reference concrete mix design, which was calibrated every week, is evaluated at the end of the chapter.



### 9.3.1 Comparison of different concrete mix designs

The graphs are similar to the ones from the cement mortar tests – maturity at the x-axis in the logarithmic scale and compressive strength at the y-axis in the linear scale. Each calibration line consists of five calibrations results – compressive strength results of five individual cubes stored in a calibration box and tested at different maturity values. One red point per concrete mix represents a validation result evaluated later in the following chapter.

The description of all three concrete mix designs related to the graph is always written above each graph. The mix design identification code in the bracket (e.g. 1W-1R) is used later to present other properties in the following tables. Changes in the concrete mix design, which were crucial for each testing week, are highlighted in bold letters. The reference concrete mix design – the one which was the same as a benchmark every week is presented in orange always.





### Comparison of concrete mixes with three different cement types:

Concrete 1 (1W-1R): C30/37 – X0, XC1-4, XD1-2, XF1, XA1 – CI 0,2 –  $D_{max} = 22 \text{ mm}$  – S4

- **CEM I 42,5 R:** 350 kg/m<sup>3</sup>, fly ash: 60 kg/m<sup>3</sup>, w-c ratio: 0,42

Concrete 2 (1W-2R): C30/37 – X0, XC1-4, XD1-2, XF1, XA1 – CI 0,2 –  $D_{max} = 22 \text{ mm}$  – S4

- **CEM II/B-S 32,5 R:** 360 kg/m<sup>3</sup>, fly ash: 58 kg/m<sup>3</sup>, w-c ratio: 0,47, reference

Concrete 3 (1W-3R): C30/37 – X0, XC1-4, XD1-2, XF1, XA1 – CI 0,2 –  $D_{max} = 22 \text{ mm}$  – S4

- **CEM III/B 32,5 L:** 370 kg/m<sup>3</sup>, fly ash: 32 kg/m<sup>3</sup>, w-c ratio: 0,49

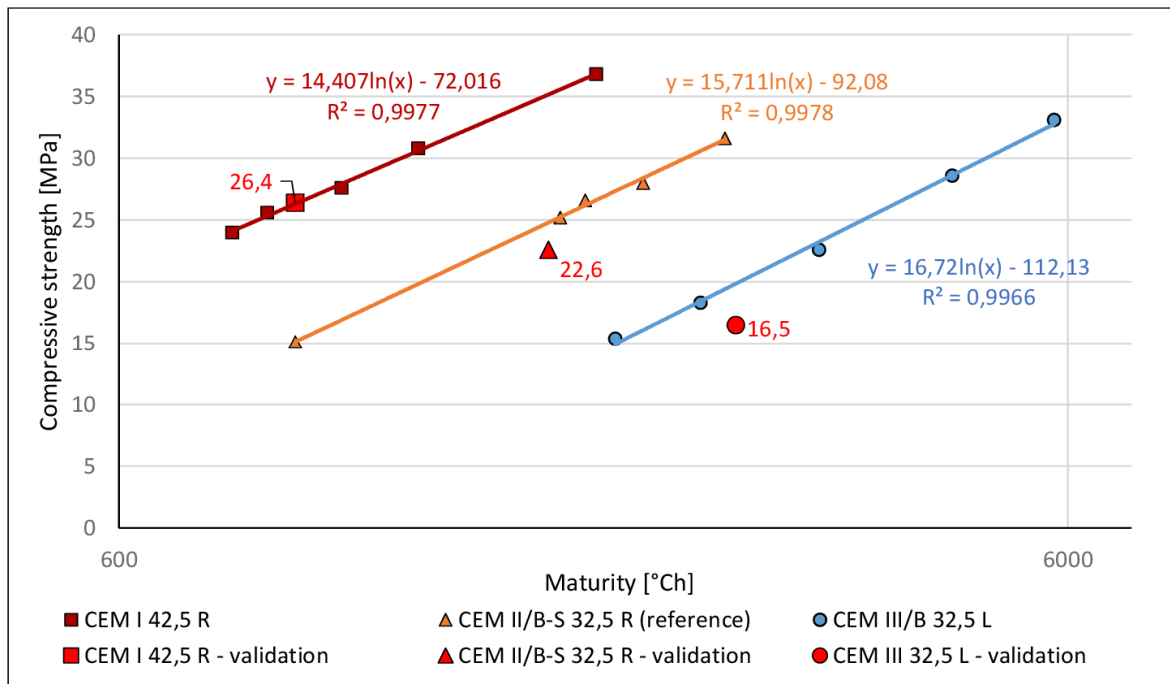

Figure 55 – Comparison of compressive strength development - three cement types

Figure 55 compares three concrete mixes, which use different cement types. The concrete specification is the same, the cement dosage is almost equal, and the fly ash dosage is similar. The water-cement ratio is slightly different to keep workability and a reasonable dosage of admixtures. Since the compressive strength class is the same C30/37, the target value of the calibration line is also the same – 70% of the 28-day value, which is 26 MPa. The recommended calibration range by the NEN 5970 18 MPa – 34 MPa was almost kept. The results show a massive influence of cement type on compressive strength development. [7]

The difference could be demonstrated at the required maturity for reaching the target value. C30/37 with CEM I 42,5 R needs 900 °Ch to reach 26 MPa, which means, for example, 1,5 days of hardening at a constant concrete temperature of 20°C. C30/37 with CEM II/B-S 32,5 R needs 1840 °Ch to reach 26 MPa, corresponding to 3 days of hardening at a constant concrete temperature of 20°C. C30/37 with CEM III/B 32,5 L needs 3870 °Ch to reach 26 MPa, equal to one week of hardening at a constant temperature of 20°C. Concrete mix with CEM II/B-S 32,5 R requires two times more maturity than concrete mix with CEM I 42,5 R to reach the value of 26 MPa. The same applies to comparing concrete mix with CEM III/B 32,5 L and CEM II/B-S 32,5 R.

**Comparison of concrete mixes with different cement amounts:**

Concrete (2W-3R): C35/45 – X0, XC1-4, XD1-3, XF1, XA1 – CI 0,2 –  $D_{max} = 22 \text{ mm}$  – S4

- **CEM II/B-S 32,5 R: 410 kg/m<sup>3</sup>**, fly ash: 48 kg/m<sup>3</sup>, w-c ratio: **0,47**

Concrete (2W-2R): C30/37 – X0, XC1-4, XD1-2, XF1, XA1 – CI 0,2 –  $D_{max} = 22 \text{ mm}$  – S4

- **CEM II/B-S 32,5 R: 360 kg/m<sup>3</sup>**, fly ash: 58 kg/m<sup>3</sup>, w-c ratio: 0,50, (reference)

Concrete (2W-1R): C25/30 – X0, XC1-2 – CI 0,2 –  $D_{max} = 22 \text{ mm}$  – S4

- **CEM II/B-S 32,5 R: 310 kg/m<sup>3</sup>**, fly ash: 68 kg/m<sup>3</sup>, w-c ratio: **0,62**

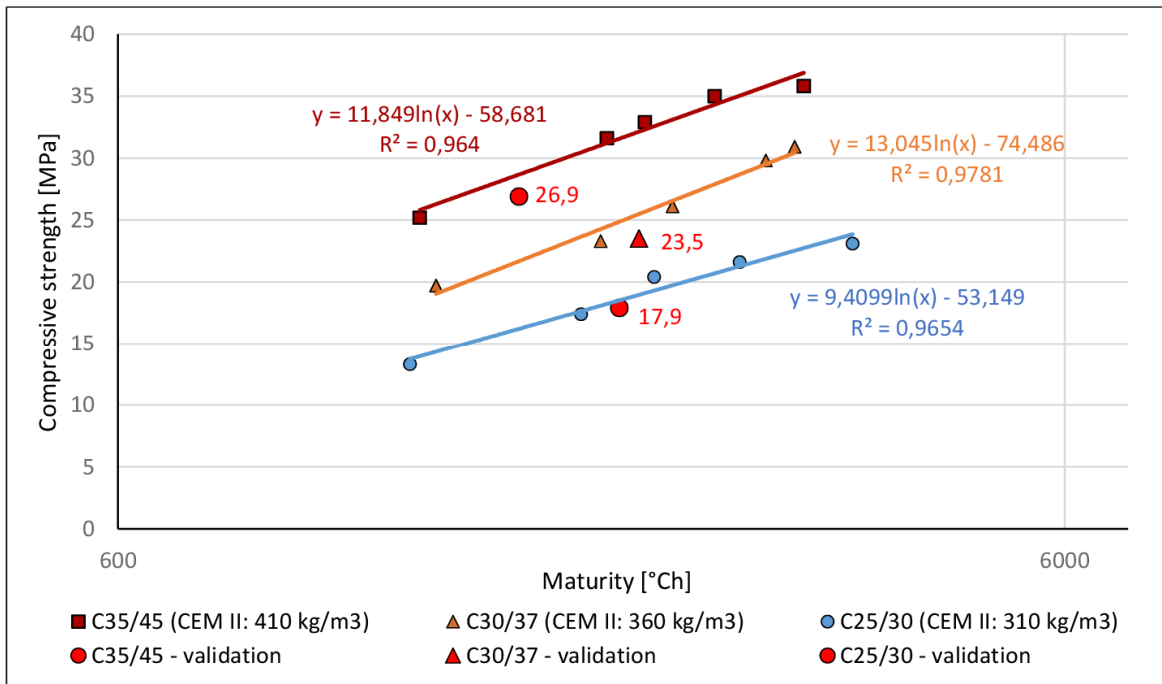

Figure 56 – Comparison of compressive strength development - different cement amount

Figure 56 compares three concrete mix designs with different cement amounts, naturally leading to three other compressive strength classes (C25/30, C30/37, C35/45). The water-cement ratio was not kept at the same value and was adapted according to the principles of concrete mix design. The values of the water-cement ratios presented above (in the specification of three mixes) are the results of a drying test. Two of them do not meet the requirements of the above-written specification acc. EN 206+A2, but this topic is clarified later, together with the result of fresh concrete tests (Chapter 9.3.3). [35]

The target values of calibration lines are 70% of the 28-day compressive strength value. Since the strength classes are different, target values are also different (21 MPa, 26 MPa, 31,5 MPa), and the ranges of calibration lines are also different (13 - 29 MPa, 18 - 34 MPa, 23,5 - 39,5 MPa). Because all calibration lines lie at the same maturity range, the difference between the concrete mixes is easier to imagine, even on a logarithmic scale. Investigated cement amounts show approximately direct proportion to concrete mix compressive strength development because both increases of cement amount, from 310 to 360 kg/m<sup>3</sup> and from 360 to 410 kg/m<sup>3</sup>, show a similar in-

crease in compressive strength development, visible as the equal vertical distance between lines. Additionally, the higher the compressive strength class is, the faster it reaches the target value. C35/45 needs 1940 °Ch to reach the target of 31,5 MPa (70% of 28-day strength). C30/37 needs approximately 300 °Ch more = 2220 °Ch to reach the target of 26 MPa (70% of 28-day strength). C25/30 needs about 600 °Ch more = 2650 °Ch to reach the target of 21 MPa (70% of 28-day strength), which means an additional 1,5 days of hardening at a constant concrete temperature of 20°C compared to C35/45.

The subsequent comparison of three concrete mixes with different grain-size curves was primarily executed by mixing two types of sand in different ratios. Reference concrete mix and concrete mix with finer grain-size curve combine two types of sand – sand B and sand D. Concrete mix with coarser grain-size curve uses Sand B only. The author is not allowed to share the names of the quarries, the detailed properties of sand, and details about the grain-size curves of concrete mixtures. For the demonstration, at least grain-size curves of used sand are presented. Figure 57 shows grain size curves of both used sand, which the author tested on a sample of sand.

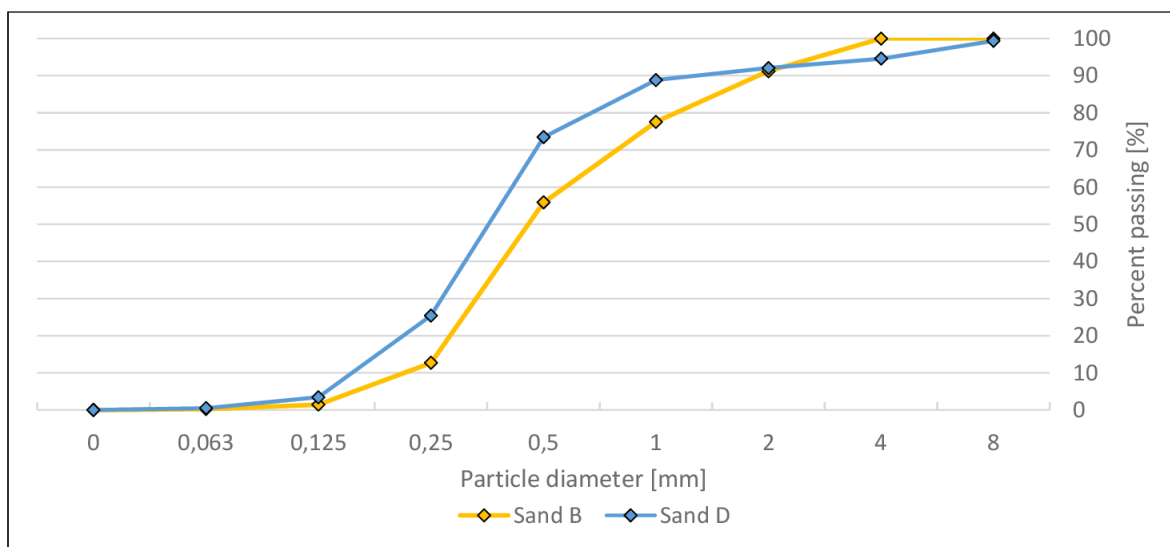

Figure 57 - Grain size curve of used sand



**Comparison of concrete mixes with different grain-size curves:**

Concrete (3W-1R): C30/37 – X0, XC1-4, XD1-2, XF1, XA1 – CI 0,2 –  $D_{max} = 22 \text{ mm}$  – S4

- CEM II/B-S 32,5 R:  $360 \text{ kg/m}^3$ , fly ash:  $58 \text{ kg/m}^3$ , w-c ratio: 0,46
- **Coarser grain-size curve**

Concrete (3W-3R): C30/37 – X0, XC1-4, XD1-2, XF1, XA1 – CI 0,2 –  $D_{max} = 22 \text{ mm}$  – S4

- CEM II/B-S 32,5 R:  $360 \text{ kg/m}^3$ , fly ash:  $58 \text{ kg/m}^3$ , w-c ratio: 0,49
- **Reference grain-size curve**

Concrete (3W-2R): C30/37 – X0, XC1-4, XD1-2, XF1, XA1 – CI 0,2 –  $D_{max} = 22 \text{ mm}$  – S4

- CEM II/B-S 32,5 R:  $360 \text{ kg/m}^3$ , fly ash:  $58 \text{ kg/m}^3$ , w-c ratio: 0,50
- **Finer grain-size curve**

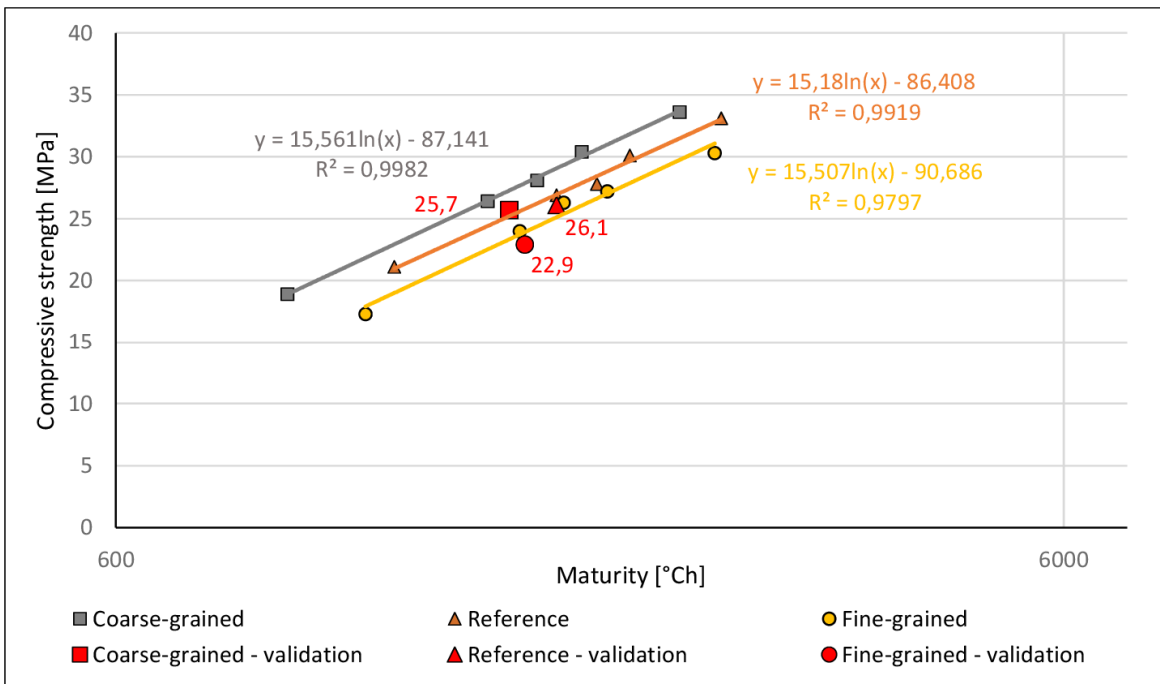

Figure 58 - Comparison of compressive strength development – three grain size curves

Figure 58 compares three concrete mixes adapted for three different grain-size curves. The aim was to keep the consistency of all three mixes similar to reach a concrete mix with equal specifications. The amount of water was slightly increased with an increasing surface of aggregates.

The difference between concrete with coarse and reference grain-size curves is 2,1 MPa, and the difference between concrete with reference and finer grain-size curves is 1,9 MPa. In total, the extremes differ from each other by about 4 MPa. The results underline fine aggregates' importance in compressive strength, as was already observed during cement mortar tests (Chapter 8.3). That also confirmed the importance of experimental determination of the maturity-strength relationship, so-called concrete calibration acc. NEN 5970, at the concrete supplier with commonly used materials, if the maturity method is used for strength determination on the construction site. [7]



### Comparison of concrete mixes with two different additions and smaller $D_{max}$ :

Concrete (4W-1R): C30/37 – X0, XC1-4, XD1-2, XF1, XA1 – CI 0,2 –  $D_{max} = 22 \text{ mm}$  – S4

- CEM II/B-S 32,5 R: 360 kg/m<sup>3</sup>, **fly ash**: 58 kg/m<sup>3</sup>, w-c ratio: 0,47, reference

Concrete (4W-2R): C30/37 – X0, XC1-4, XD1-2, XF1, XA1 – CI 0,2 –  $D_{max} = 16 \text{ mm}$  – S4

- CEM II/B-S 32,5 R: 370 kg/m<sup>3</sup>, fly ash: 66 kg/m<sup>3</sup>, w-c ratio: 0,49

Concrete (4W-3R): C30/37 – X0, XC1-2 – CI 0,2 –  $D_{max} = 22 \text{ mm}$  – S4

- CEM II/B-S 32,5 R: 360 kg/m<sup>3</sup>, **limestone**: 58 kg/m<sup>3</sup>, w-c ratio: 0,51

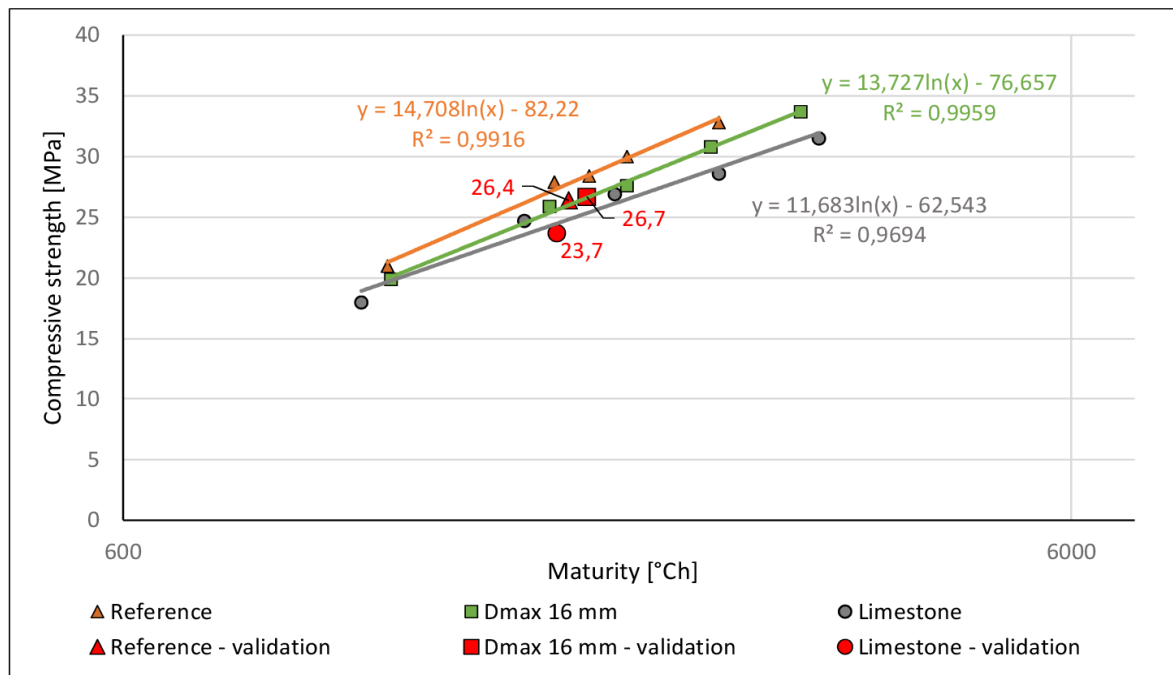

Figure 59 - Comparison of compressive strength development - smaller  $D_{max}$ , additions (fly ash, limestone)

Figure 59 compares reference concrete mix, concrete mix with a smaller maximum grain size and concrete mix with limestone. As written in the specification above, two types of additions are used: fly ash and limestone. The reference concrete mix design and the mix design with limestone use identical dosages – 58 kg/m<sup>3</sup>, which allows exact comparison. Concrete mix with limestone shows slower compressive strength development with a difference of approximately 3 MPa. However, it is necessary to consider that measured water content of both concrete mixes differs slightly.

The calibration line of concrete mix adapted to a smaller maximum size of aggregates helps to answer quite common question in practice. If the calibration for a particular concrete mix design with  $D_{max} 22 \text{ mm}$  is done but an alternative with  $D_{max} 16 \text{ mm}$  is needed, e.g. because of pumping of concrete or more tight reinforcement of structural element, there is usually a question: Does the calibration need to be done again for  $D_{max} 16 \text{ mm}$  or what can be the difference between concrete mix design with  $D_{max} 16 \text{ mm}$  and  $22 \text{ mm}$ ? The result proved that concrete with a smaller maximum grain size shows slightly slower strength development, about 1,6 MPa, which is not significant. The same calibration line could be used if a possible difference of 1,5 – 2 MPa is considered. The result matches well with previous investigations of different grain size curves, where coarser grains reached higher strength.



**Comparison of concrete mixes with winter measures:**

Concrete (5W-1R): C30/37 – X0, XC1-4, XD1-2, XF1, XA1 – CI 0,2 –  $D_{max} = 22 \text{ mm}$  – S4

- CEM II/B-S 32,5 R:  $360 \text{ kg/m}^3$ , fly ash:  $58 \text{ kg/m}^3$ , w-c ratio: 0,49
- **Reference concrete mix design**

Concrete (5W-2R): C30/37 – X0, XC1-4, XD1-2, XF1, XA1 – CI 0,2 –  $D_{max} = 22 \text{ mm}$  – S4

- CEM II/B-S 32,5 R:  $360 \text{ kg/m}^3$ , fly ash:  $58 \text{ kg/m}^3$ , w-c ratio: 0,48
- **Shortened workability**

Concrete (5W-3R): C30/37 – X0, XC1-4, XD1-2, XF1, XA1 – CI 0,2 –  $D_{max} = 22 \text{ mm}$  – S4

- CEM II/B-S 32,5 R:  $360 \text{ kg/m}^3$ , fly ash:  $58 \text{ kg/m}^3$ , w-c ratio: 0,48
- **Shortened workability and added setting accelerator**

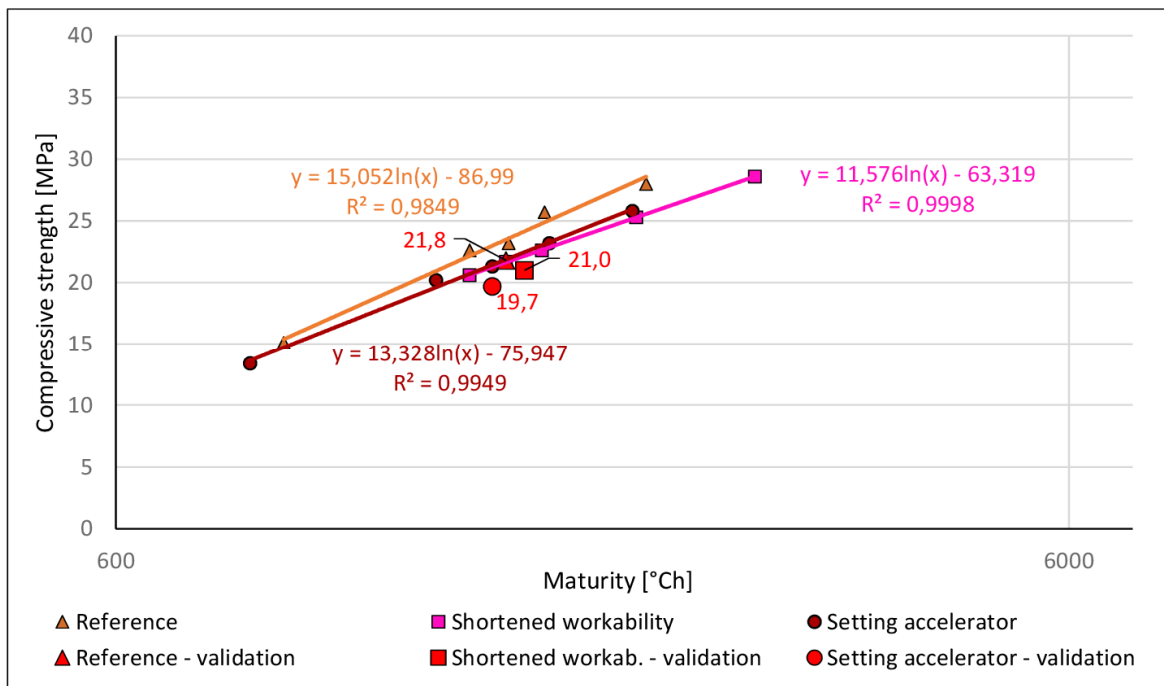

Figure 60 - Comparison of compressive strength development - shortened workability, setting accelerator

Figure 60 compares the reference concrete mix design and two mix designs adapted for cold weather concreting. Both mix designs have different mixtures of used admixtures. The first has shortened workability, and the second contains even a setting accelerator.

The compressive strength development of both concrete mix designs is slightly slower at a later age. However, the hardening is not influenced dramatically. The difference compared to the reference mix design is approx. 1,4 MPa in the range around the target value. Winter concrete mix design need maturity approx. of 440 °Ch more to reach the target value of 26 MPa. It is equal to 15 hours more at a constant concrete temperature of 10°C.

Figure 61 illustrates the development of penetration resistance of all three mixes. This is shared only as complementary information for a better explanation of the behaviour of those concrete mixes at a very early age. The development of penetration

resistance in time was measured during the determination of setting time acc. ČSN 731332. [65]

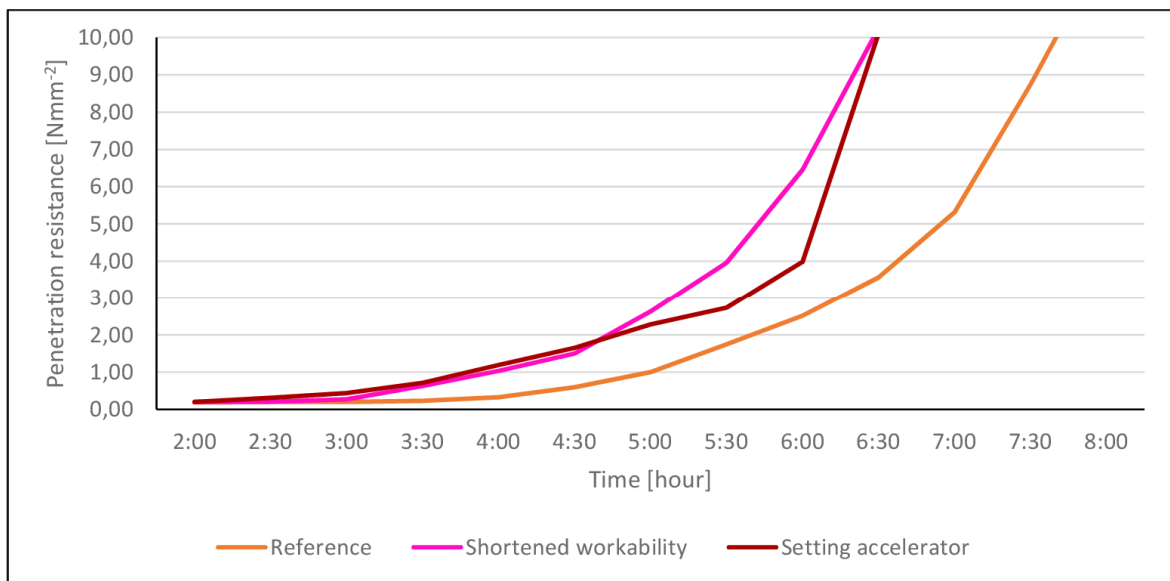

Figure 61 – Development of penetration resistance

### 9.3.2 Validation results

The validation results presented in the figures above are evaluated in Table 9. One test result (in column "tested value") is an average compressive strength value of three cubes tested at a specific maturity value. Those three samples were stored in covered plastic moulds in slightly colder conditions than the calibration samples. The temperature of one cube was monitored, and the remaining two cubes were supposed to have very similar temperatures. The testing of the cubes was performed when the estimated strength was within the range of calibration, which was done in parallel with validation.

The safety factor in the table was calculated according to standard NEN 5970 (Chapter 5.2.1), which typically reduces the calculated compressive strength by the maturity method. The calculated difference in Table 9 does not include any safety factor. It is purely the compressive strength estimated by the maturity method (excl. safety factor) subtracted from the destructively tested strength. A negative result means that the maturity method provides a higher value than the actual tested value. The safety factor is considered and shown in the safety margin, which indicates how safe the estimated result by maturity method is, including the safety factor.

The safety factor safely covered most of the compressive strength results calculated by the maturity method. Only one result (1W-3R) deviates 3,3 MPa from the tested results, and the safety factor of 2,5 MPa is insufficient to cover this high deviation. Most of the results estimated by the maturity method are more optimistic than the tested values. The average deviation of -1,27 MPa and the mean value of the deviation of



-1,3 MPa indicates a slight systematic influence of the variations because the value of the two statistic values is not close to zero, as presented in Figure 62.

Table 9 - Results of validation samples

Concrete mix design		Validation					
No.	Description	Maturity method			Destructive test	Difference (tested - measured) [MPa]	Safety margin [MPa]
		Strength incl. safety factor [MPa]	Safety factor [MPa]	Strength excl. safety factor [MPa]	Tested value [MPa]		
1W-1R	CEM I	23,1	3,1	26,2	26,4	0,2	3,3
1W-2R	CEM II/B-S	22,0	2,7	24,7	22,6	-2,1	0,6
1W-3R	CEM III/B	17,3	2,5	19,8	16,5	-3,3	-0,8
2W-1R	C25/30	16,1	2,4	18,5	17,9	-0,6	1,8
2W-2R	C30/37	22,6	2,8	25,4	23,5	-1,9	0,9
2W-3R	C35/45	25,7	2,9	28,6	26,9	-1,7	1,2
3W-1R	Coarse-grained	24,3	2,9	27,2	25,7	-1,5	1,4
3W-2R	Fine-grained	21,2	2,7	23,9	22,9	-1,0	1,7
3W-3R	Reference	23,9	3,0	26,9	26,1	-0,8	2,2
4W-1R	Reference	24,7	3,0	27,7	26,4	-1,3	1,7
4W-2R	Dmax 16mm	23,7	2,9	26,6	26,7	0,1	3,0
4W-3R	Limestone	21,7	2,8	24,5	23,7	-0,8	2,0
5W-1R	Reference	21,0	2,4	23,4	21,8	-1,6	0,8
5W-2R	"R"	19,6	2,5	22,1	21,0	-1,1	1,4
5W-3R	"R" + Accelerator	19,2	2,2	21,4	19,7	-1,7	0,5

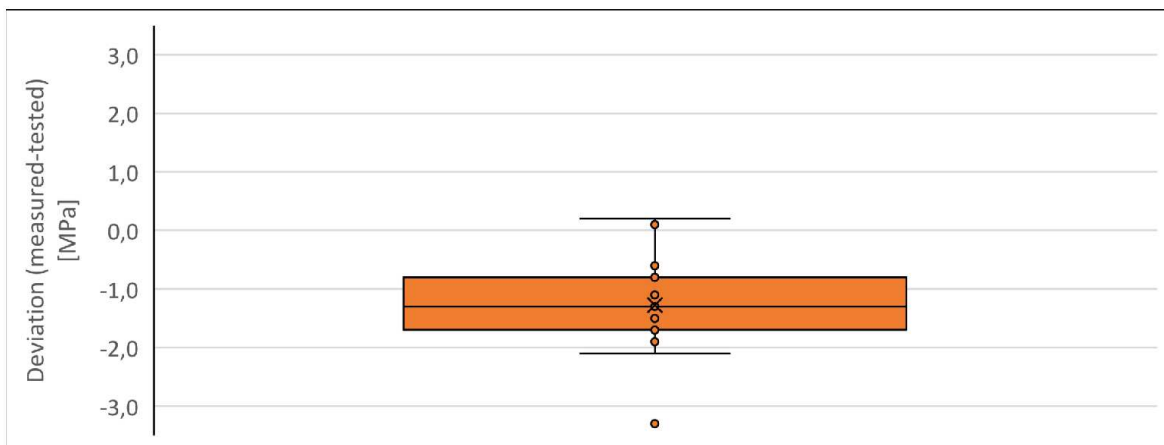

Figure 62 - Results of validation - box plot



The author tried to avoid systematic influences during the validation as much as possible. Concrete samples for calibration and validation were created from the same batch of concrete, and the validation samples were prepared right after the calibration samples.

### 9.3.3 Results of test of fresh and hardened concrete

Table 10 presents the fresh concrete tests of the concrete mix designs shown above (for a more transparent overview, some of the results are given in a scale of colours). The specified consistency class of all mix designs was S4, which requires a slump test between 16 cm and 21 cm. The standard EN 206+A2 allows a margin of  $\pm 3$  cm. Most concrete mixes fulfil the specified consistency if this margin is considered. Only two of them had a lower slump (10 cm, 12 cm = S3), and two had a higher slump (25 cm, 26 cm = S5). Values of air content vary from 1,8 to 2,9 %, which are typical values in practice. The density of fresh concrete shows relatively stable results from 2294 kg/m<sup>3</sup> to 2345 kg/m<sup>3</sup>. Two values of the water-cement ratio are presented – the value calculated by the mixing software and the tested value (by drying the sample). [35]

Table 10 - Results of fresh concrete tests

Concrete mix design		Slump test		Air content [%]	Density [kg/m <sup>3</sup> ]	Water-cement ratio			
No.	Description	Slump [cm]	Consistency			w-c mixing	water amount (tested) [kg/m <sup>3</sup> ]	w-c tested	$\Delta$ w-c
1W-1R	CEM I	24	S5	2,9	2334	0,37	157,0	0,42	0,05
1W-2R	CEM II/B-S	24	S5	1,9	2309	0,36	174,6	0,47	0,11
1W-3R	CEM III/B	26	S5	1,8	2318	0,41	183,2	0,49	0,08
2W-1R	C25/30	10	S3	2,5	2309	0,53	201,5	0,62	0,09
2W-2R	C30/37	12	S3	2,7	2311	0,45	186,5	0,50	0,05
2W-3R	C35/45	24	S5	2,2	2296	0,38	199,2	0,47	0,09
3W-1R	Coarse-grained	24	S5	1,9	2345	0,36	169,7	0,46	0,10
3W-2R	Fine-grained	25	S5	2,1	2294	0,40	186,8	0,50	0,10
3W-3R	Reference	24	S5	2,0	2311	0,39	183,5	0,49	0,10
4W-1R	Reference	22	S5	2,5	2340	0,44	173,9	0,47	0,03
4W-2R	Dmax 16mm	21	S4	2,8	2318	0,43	188,1	0,49	0,06
4W-3R	Limestone	21	S4	2,0	2335	0,46	185,2	0,51	0,05
5W-1R	Reference	22	S5	2,2	2311	0,43	182,4	0,49	0,06
5W-2R	"R"	23	S5	1,9	2306	0,43	180,0	0,48	0,05
5W-3R	Accelerator	21	S4	1,9	2325	0,41	177,0	0,48	0,07



Those two values differ from each other up to 0,11. The water absorption of aggregates could influence this because the mixing software could use a lower estimation of the moisture of aggregates. In the case of two concrete mix designs (2W-1R, 2W-3R), the tested water-cement ratio did not meet the requirements of the exposure class.

Table 11 - Results of hardened concrete

Concrete mix design		Hardened concrete					
No.	Description	Density [kg/m <sup>3</sup> ]	2-day comp. strength [MPa]	7-day comp. strength [MPa]	28-day comp. strength [MPa]	90-day comp. strength [MPa]	Depth of penetration of water [mm]
1W-1R	CEM I	2343	30,9	43,7	52,9	64,1	24
1W-2R	CEM II/B-S	2353	18,1	33,6	50,0	62,7	18
1W-3R	CEM III/B	2313	11,1	23,9	47,5	63,3	19
2W-1R	C25/30	2276	14,0	24,5	37,8	48,2	8
2W-2R	C30/37	2303	19,3	30,8	45,2	55,6	16
2W-3R	C35/45	2334	23,1	36,4	53,0	63,7	10
3W-1R	Coarse-grained	2348	12,0	36,9	51,5	68,8	5
3W-2R	Fine-grained	2296	11,3	32,8	47,1	58,5	5
3W-3R	Reference	2313	15,5	32,8	51,7	64,2	6
4W-1R	Reference	2323	19,0	34,5	48,6	63,2	28
4W-2R	Dmax 16mm	2297	19,9	35,5	49,0	61,6	12
4W-3R	Limestone	2355	16,9	33,8	44,0	56,8	8
5W-1R	Reference	2313	14,0	32,6	48,3	59,6	15
5W-2R	"R"	2308	13,9	32,5	45,9	61,2	5
5W-3R	Accelerator	2337	12,7	30,4	44,1	58,3	6

Table 11 shows tests of hardened concrete: density, compressive strength and depth of penetration. Compressive strength was tested after two, seven, twenty-eight and ninety days. The process used at the concrete supplier was followed to get results from practical curing conditions, as they normally do. After the sampling, samples were stored in the storage of the concrete supplier, where the temperature is not constant and could be influenced by factors such as outside temperature, open doors, or room heating. The next day, the samples were transported to the lab, demoulded and placed into a water bath at approximately 20°C. Samples were stored in the water bath until the testing. 2-day samples are unsuitable for interpretation of the results because half of the storage time (first day) is at unknown temperature conditions. Moreover,



the samples are not often tested precisely after two days in practice, which could quite influence the results, especially within this short period (two days). However, 7-day samples are suitable for observing the early-age strength because most of the storage time, more precisely 6/7, is at defined conditions (water bath at 20°C), and if the sample is tested a bit later or earlier, the difference is not that significant. Strength results are discussed in more detail during the evaluation of repeated calibration below. The results of density show consistent values. The maximum water penetration depth was 28 mm, which is still acceptable for used concrete mix designs.

### 9.3.4 Repeated calibration of the reference concrete mix design

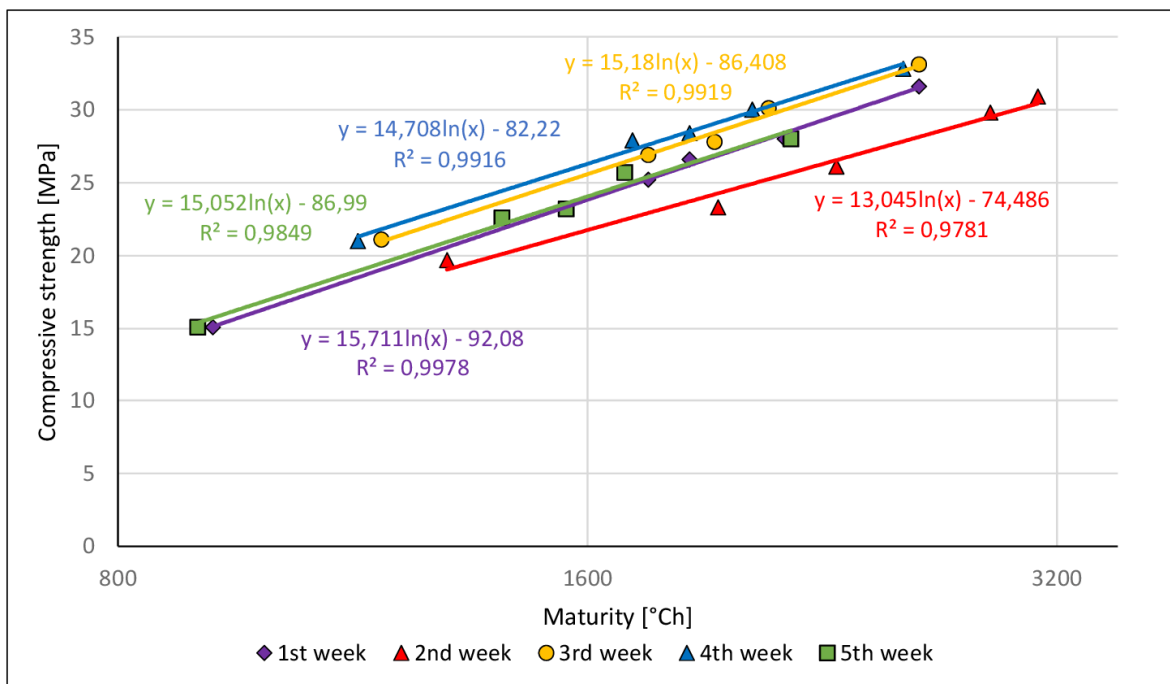

Figure 63 - Repeated calibration of the same concrete mix design

Figure 63 compares calibration lines of the same (reference) concrete mix designs, executed five times within 1,5 months. The calculated safety factor of all calibration lines varies from 2,4 MPa (5<sup>th</sup> week) to 3,0 MPa (3<sup>rd</sup> and 4<sup>th</sup> week). In this case, the main influence of safety factors is the calibration range's mean value. In calculating the safety factor, the estimation of the 28-day value of the mean strength (characteristic cube strength + 8 MPa) is used instead of the actual average tested strength because the value is usually unavailable if calibration is executed in practice (equation in Chapter 5.2.1).

The calibration lines of four concrete batches provided similar results, and safety factors safely covered deviations between them. The exception is the calibration from the second week, where the line was significantly lower. The safety factor of this calibration line (2,8 MPa) is insufficient to cover the decreased strength values compared to the results from the third or fourth week. Those results initiated the experimental part of repeated validation, which is presented in Chapter 10.



Table 12 presents test results related to batches shown in Figure 63. Concrete mix from the second testing week with low calibration values also evinced different consistency and the lowest 7-day and 28-day compressive strength compared to others.

Table 12 - Results of tests - repeated calibration

No.	Slump test		Air content [%]	Density	Water-cement ratio		Hardened concrete		
	Slump [cm]	Consistency		$\rho_c$ [kg/m <sup>3</sup> ]	Amount of water [kg/m <sup>3</sup> ]	w/c	Density [kg/m <sup>3</sup> ]	7-day comp. strength [MPa]	28-day comp. strength [MPa]
1W-2R	24	S5	1,9	2309	174,6	0,47	2353	33,60	50,00
2W-2R	12	S3	2,7	2311	186,5	0,50	2303	30,80	45,17
3W-3R	24	S5	2,0	2311	183,5	0,49	2313	32,80	51,66
4W-1R	22	S5	2,5	2340	173,9	0,47	2323	34,50	48,63
5W-1R	22	S5	2,2	2311	182,4	0,49	2313	32,60	48,32

## 9.4 Summary

Executed experimental analysis clarified the influences of changes in the concrete mix design on the compressive strength development. In total, 15 batches of concrete were analysed, and 135 early-age samples were created. The change in cement type and the noticeable increase or decrease in cement amount ( $\pm 50 \text{ kg/m}^3$ ) influence compressive strength significantly. The different amounts of cement (310, 360, 410  $\text{kg/m}^3$ ) proportionally changed strength development in the investigated calibration range. Modification of the grain-size curve affects the compressive strength visibly (within 4 MPa). It emphasises the importance of sand as a local material and the importance of calibrating concrete. Fly ash substitution for limestone results in a visible drop of approximately 3 MPa, especially in later ages. Adapting the concrete mix design for a smaller maximum grain size (from 22 mm to 16 mm) causes only a slight decrease in strength development of about 1 – 2 MPa. The same applies to standard winter measures such as shortened workability or usage of a setting accelerator.

Five repeated calibrations provided four similar calibration lines and one line with significantly lower strength values. The drop in compressive strength was also observed in regular tests (such as 7-day and 28-day specimens). The following experimental part is planned based on those results, where calibration is repeatedly validated on the construction site. This investigation directly provides a more transparent overview of deviations on the construction site. The place of experimental work moves now from the concrete supplier to the construction site, where even higher variations are expected.



## 10 Concrete validation

The results of the previous experimental part at the concrete plant indicated possible deviations which could occur in practice. This experimental part investigates the topic of variations in concrete production in more detail directly at the construction site before pouring concrete. The aim was to include most of the possible deviations from concrete production till concrete pouring, except those which can occur during concrete pouring into a structure.

The experiment was based on the principle of validation acc. NEN 5970, which is described in Chapter 5.4. Calibration of a particular concrete mix design was done at the concrete plant. Then, the calibration curve was regularly validated on the construction site using concrete samples produced during concrete pouring and tested at the concrete laboratory. The sampling and testing were distributed over half a year to receive the results from different weather conditions. [7]

### 10.1 Procedure

The experiment was performed at a particular residential project in the southern part of Prague, Czech Republic. The concrete plant which supplied concrete for the project was situated approximately 8 km from the construction site. Two concrete mix designs, which were mainly used for walls, were calibrated and regularly validated. The concrete specification was C25/30 – XC2 – Cl 0,2 –  $D_{max} = 16$  mm – S3. The concrete mix design for the wall on that particular construction site, which could also be used for a slab, was chosen purely because of the practical reason – walls are poured more often than slabs. The target value was considered as 70% of the characteristic 28-day value, which means 21 MPa because the aim was to investigate slab scenarios = estimating the time for removal of slab formwork. The safety factor was calculated in accordance with NEN 5970, particularly 2,7 and 2,9 MPa. [7; 66; 67]

Regular validation sampling from the concrete truck was usually done on the construction site twice a month. The testing took place from 12/2021 to 05/2022. The whole validation process was repeated continuously in the same way to avoid any additional deviations related to different sampling, sample curing and testing.

At first, a concrete sample was taken from a concrete truck during concrete pouring on the construction site (Figure 64). After that, three samples (cubes) were created and stored in the site office for approximately three days at an ambient temperature of around 20°C (Figure 64). Creation and storage of samples complied with EN 12350-1 and EN 12390-2. The temperature of all samples was recorded, and compressive strength was calculated. When the computed value came closer to the target value, samples were transported to the laboratory and tested in a compressive strength testing machine following EN 12390-3. In the end, both values (calculated and tested) were compared and assessed in comparison with the safety factor acc. NEN 5970. The author of the thesis did all the steps mentioned above, which did not introduce additional

deviations in the process because everything was created and tested by one person using the same procedure. [7; 44; 45; 46]



Figure 64 - Prepared samples (left), curing conditions and monitoring (right) [photo: author]

Three samples per validation were always created, but only two of them were monitored during the hardening if the third sensor had to be used in another project. That is the reason why, several times, only two results per validation are presented.

## 10.2 Results

The following concrete mix designs were calibrated within the experimental part Calibration 15.11.2021: C25/30 – X0, XC1-2 – CI 0,2 –  $D_{max} = 22 \text{ mm}$  – S3

- CEM II/B-S 32,5 R: 320 kg/m<sup>3</sup>, fly ash: 32 kg/m<sup>3</sup>, limestone: 22 kg/m<sup>3</sup>, w-c: 0,54

Calibration 21.02.2022: C25/30 – X0, XC1-2 – CI 0,2 –  $D_{max} = 16 \text{ mm}$  – S3

- CEM II/B-S 32,5 R: 330 kg/m<sup>3</sup>, fly ash: 65 kg/m<sup>3</sup>, limestone: 0 kg/m<sup>3</sup>, w-c: 0,50
- + setting accelerator

Calibration 09.05.2022: C25/30 – X0, XC1-2 – CI 0,2 –  $D_{max} = 16 \text{ mm}$  – S3

- CEM II/B-S 32,5 R: 330 kg/m<sup>3</sup>, fly ash: 35 kg/m<sup>3</sup>, limestone: 26 kg/m<sup>3</sup>, w-c: 0,51

The prepared calibration curve (from 15.11.2021) was not used because of the change in delivered concrete mix to the construction site. The following two calibration curves were validated several times. The concrete mix design with a setting accelerator was used mainly in winter and early spring. The concrete mix design without a setting accelerator was used in later spring.

The calibration curves of all three mix designs are very similar (Figure 65). The maximum difference between them is about 3 MPa. Slightly slower compressive strength development in the case of the concrete mix design with a setting accelerator compared to the concrete mix design without an accelerator confirms the findings from the test at the concrete plant (Chapter 9.3.1). The difference between concrete mix designs with  $D_{max} = 16 \text{ mm}$  and  $D_{max} = 22 \text{ mm}$  contradicts the finding in Chapter 9.3.1. In this case, the mix design with a maximum aggregate size of 16 mm shows slightly faster strength development. However, the difference is negligible, and



the time between both calibrations is more than half a year when many changes could occur.

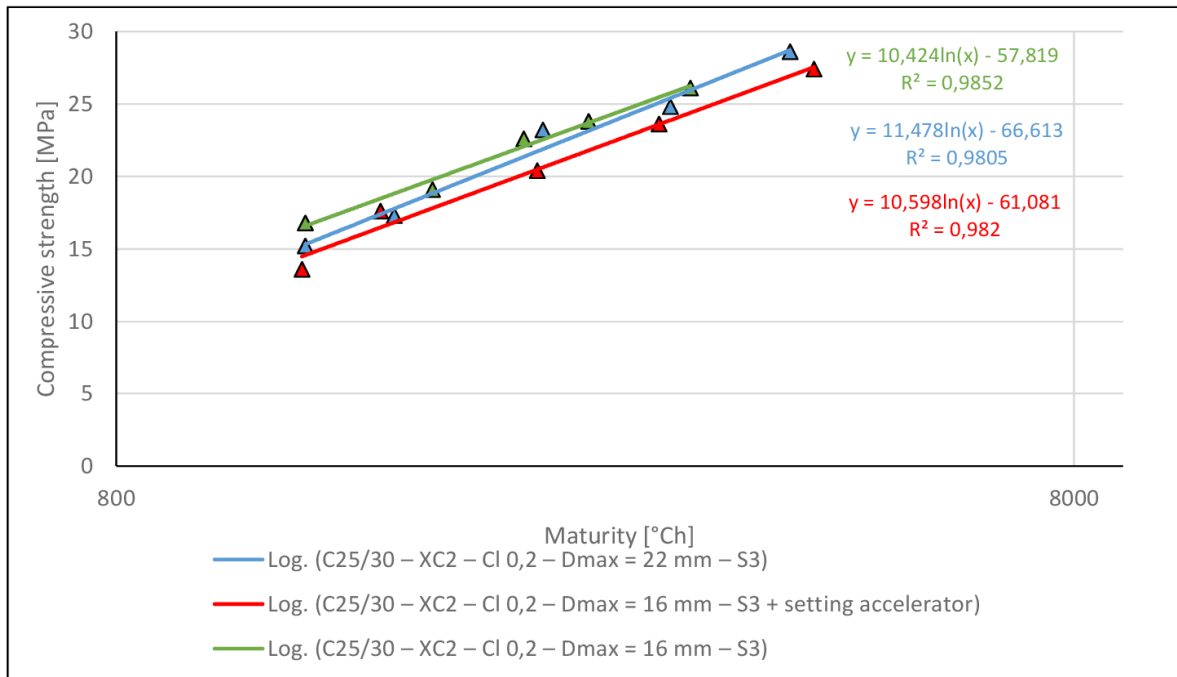

Figure 65 - Calibration curves of tested concrete mix designs

Figure 66 shows the sampling dates of validation samples, including the ambient and fresh concrete temperatures. It proves that fresh concrete temperature was quite stable during the whole experiment, especially in the winter when fresh concrete temperature varies between 11,8°C and 16,8°C. During winter time, concrete plant uses heated water for concrete production. Figure 66 also confirms that the whole experiment covers different temperature conditions varying from 0,3°C to 22°C. Besides the temperature range, different weather was experienced (such as snowfall, rain, or sunshine).

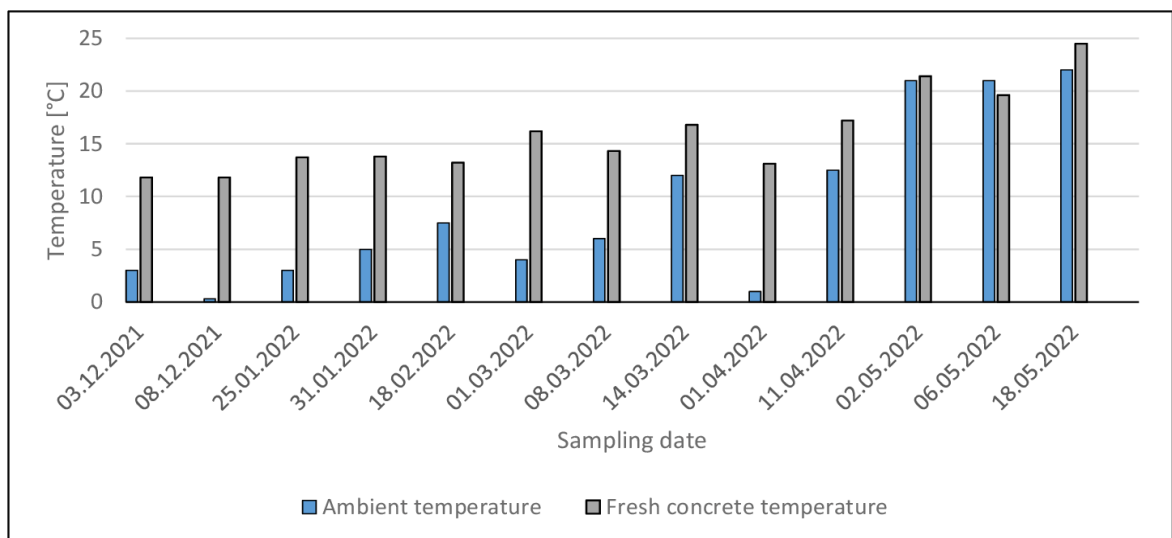

Figure 66 - Sampling dates, ambient temperature and fresh concrete temperature

Figure 67 presents the validation results of the winter concrete mix design with a setting accelerator. Regularly destructively tested validation samples are given as circular points based on measured and calculated maturity. The results of calibration samples are shown as orange triangles. The orange line represents the calibration curve, and the dashed red lines show the safety factor value subtracted and added to the calibration curve. The safety factor for this specific calibration curve was 2,7 MPa and was calculated based on a determined standard deviation of the production according to the standard NEN 5970. A calibration curve with subtracted safety factors should be used in the construction projects of reinforced structures. In the presented case, it would be the dashed red curve below.

In this case, the maturity method would overestimate every result below the lower red dashed line because the negative deviation is higher than the safety factor. All results are almost evenly distributed within the safety range. The only exception is one result from the first validation, slightly above the upper dashed line. However, this deviation is safe because the calculated result is underestimated compared to the actual one. Seven sets of validation samples proved acceptable deviations, covered by a safety factor.

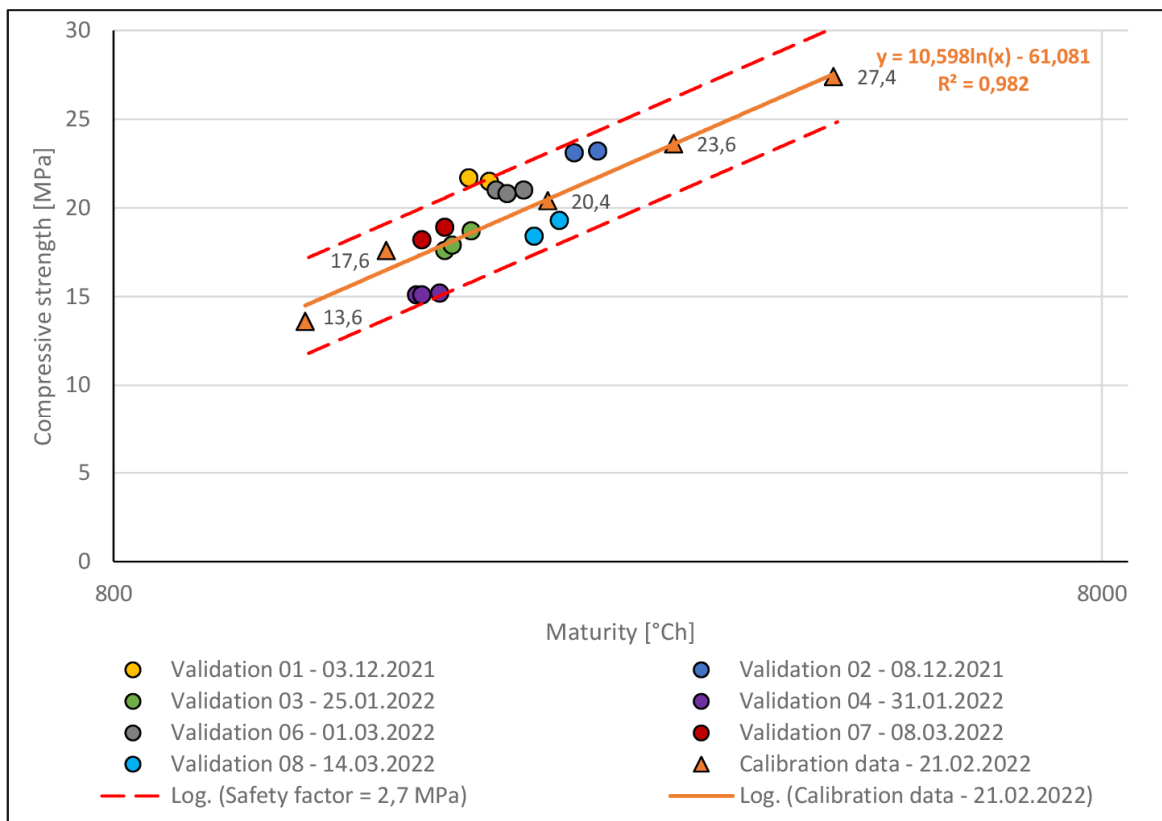

Figure 67 – Validation results performed on the construction site – winter concrete mix

Figure 68 presents the validation results of the summer concrete mix design without a setting accelerator. Circular and square-shaped points represent regularly tested validation samples. However, square-shaped points indicate concrete adaption by adding additional water to the concrete mix on the construction site. This negative



adaption seems to be the reason for the insufficient performance of the concrete mix during validation no. 5 and 12. Higher negative deviation also occurred during validation no. 9, but the difference between the safety factor and the highest deviation of 0,8 MPa could still be acceptable.

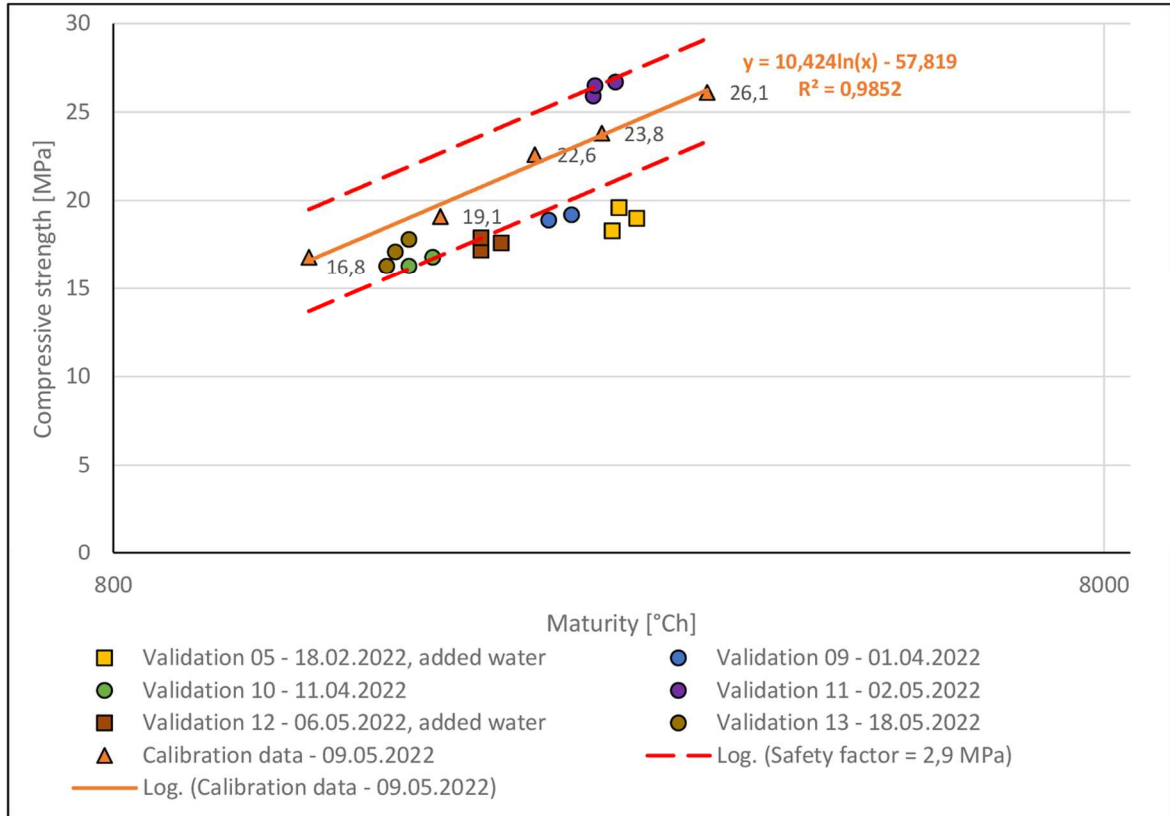

Figure 68 - Validation results performed on the construction site - summer concrete mix

### 10.3 Summary

The experimental analysis investigated the deviations of the maturity method in the practice. Sixty-three samples were created in the field, including some complementary testing. Performed validations confirmed that the maturity method allows the safe determination of compressive strength on the construction site because most of the validations were successful. In detail, ten validations provided results within the range of safety factors. Adding water to the concrete affected two validations, resulting in lower strength results. One validation resulted in a slightly lower strength value.

The observation of unprofessional adaption of a concrete mix by added water and lower early-age performance of concrete confirms the importance of site discipline. The issue of additionally added water on the construction site, and its influence on the strength development of concrete was identified as an essential topic and is investigated in the following experimental part. Besides that, routine quality checks at the concrete supplier are necessary for stable quality.



## 11 Influence of added water

The primary motivation to start this experimental part was previous experiment results and observation of adding water to the concrete mix on the construction site. The motivation of workers to ask concrete truck drivers to add water to the concrete mix is the more effortless workability of concrete. Additional water in concrete changes the consistency and makes the concrete mixture more liquid. It makes pouring easier and increases the probability of successfully filling complicated shapes. It could be the easiest and cheapest way to modify concrete consistency, but only from the worker's or foreman's point of view.

However, this adaptation of the concrete mix does more harm than good. Additional water in the concrete mix makes the hardened concrete more porous and worsens the properties (such as compressive strength, water tightness, carbonation resistance, and others). Higher water content also increases the risk of segregation. This procedure is not correct, and another approach should be taken.

At first, suitable concrete consistency should be ordered considering the type of structure, its shape, reinforcement ratio, and pouring procedure. It means ordering concrete mix with consistency class (e.g. S4) rather than trying to save some euros by ordering (e.g. S3), which will be later adapted on the job site with additional water.

If the consistency of the delivered concrete does not comply with the ordered one, the following procedure should be taken. The actual consistency should be tested, e.g. by performing a slump test. If the concrete is less fluid than it should be and the tested value confirms that (e.g. S3 instead of S4), consistency could be adapted using the recommended superplasticiser from the concrete supplier. Before using superplasticiser, the person who doses superplasticiser should climb up the ladder on a concrete truck to see the inside of a concrete drum. Concrete should be „unscrewed“ as close as possible to the feed opening. After applying the recommended dosage of suitable superplasticiser, the spot where the superplasticiser was poured should be washed with a small batch of water (e.g. 5 litres). It will later support the distribution of superplasticiser within the concrete batch. Concrete should be mixed for several minutes by turning the concrete drum of the concrete truck. After the mixing, consistency should be tested again. If the consistency complies with the delivery sheet, concrete pouring can start. The above-described procedure allows the adaptation of concrete consistency without significant impact on concrete quality.

This experimental part should answer the following questions. Can adding 80 or 160 litres of water to the 8 m<sup>3</sup> big concrete truck dramatically decrease the compressive strength of concrete? How do superplasticisers or water additionally affect selected concrete properties – consistency, compressive strength, and density?



## 11.1 Procedure

The experiment took place at the concrete plant to gain valid results from practice. First, one cubic meter of the selected concrete mix was mixed and poured into the concrete truck following the standard procedure. Then, concrete was poured from the concrete truck into four tanks with a volume of 0,2 m<sup>3</sup> (Figure 69). The concrete mix in the first tank was not adapted and used as a reference for mixed concrete. Concrete batches in the remaining three tanks were adjusted in order to reach better consistency (Figure 69). Water was added into the second and third concrete tanks, which should represent a wrong way of consistency improvement on the construction site. Two litres of water were added into the second concrete tank (10 l/m<sup>3</sup> additionally) and four litres of water into the third concrete tank (20 l/m<sup>3</sup> additionally). The consistency of concrete in the fourth tank was adapted following the recommended procedure – the addition of superplasticiser mixed with a small amount of water for better distribution of superplasticiser within the concrete batch. After those adaptations of concrete mixes, concrete was properly mixed using an electric concrete mixer and a shovel (Figure 70).



Figure 69 - Preparation of concrete batches, three concrete batches before adaption [photo: author]



Figure 70 - Mixing of adapted concrete batches, early-age compressive strength samples [photo: author]



Right after the mixing, the following tests were performed by the author of the thesis, and samples were prepared:

- Slump test
- Density
- Air content
- Samples for determination of the water-cement ratio
- Early-age compressive strength samples
- 28-day compressive strength samples

Consistency (EN 12350-2), density (EN 12350-6), and air content (EN 12350-7) were determined according to the standard procedure described in mentioned standards. The water-cement ratio was determined by drying an approximately 3,5 kg concrete batch. Early-age and 28-day samples were created and cured according to EN 12350-1 and EN 12390-2. The calibration curves of all four differently adapted concrete mix designs (acc. NEN 5970) were determined based on sequential testing of early-age compressive strength samples and continuous temperature monitoring. The cubes were stored in the room at a constant temperature of 21°C. (Figure 70). [7; 45; 46; 62; 63; 64]

## 11.2 Results

Concrete of the following specification was used: C30/37 – XC4, XD2, XF1, XA1 – CI 0,2 –  $D_{max}$  16 mm – S4. The mixed concrete mixes (reference) demonstrated a delivered concrete with the wrong consistency class. The tested consistency was S2 compared to the required S4. The air content of the concrete mix was 2,7 %, which is a common value. Table 13 shows the results of fresh concrete properties. Adding 0,4 l/m<sup>3</sup> superplasticiser and 1,0 l/m<sup>3</sup> water improved concrete consistency equally as 10 l/m<sup>3</sup> of water. The slump test result was 14 cm (S3). Adding 20 l/m<sup>3</sup> of water to the concrete resulted in an 18 cm slump (S4). The experimentally determined water content confirms the trend of performed adaptations despite the measured amount showing a lower increase in water content. This was most likely influenced by quite a long time of the whole experiment execution.

Table 13 - Differently adapted concrete mixes – fresh concrete properties

Identification		Slump test		Air content [%]	Water-cement ratio				
Strength class	Description	Slump [cm]	Consistency		m <sub>water</sub> [kg/m <sup>3</sup> ]	m <sub>cement</sub> [kg]	m <sub>fly ash</sub> [kg]	w/c	Δ w/c
C30/37	Reference	50	S2	2,7	172,3	370	60	0,45	0,00
-	10l/m <sup>3</sup>	140	S3	-	177,6	370	60	0,46	0,01
-	20l/m <sup>3</sup>	180	S4	-	179,2	370	60	0,47	0,02
-	Superplasticizer	140	S3	-	171,6	370	60	0,45	0,00



Table 14 presents the density, 28-day compressive strength, and water penetration depth of concrete. Shown 28-day strength values are the average results of three samples. The results confirm that added superplasticiser does not significantly reduce 28-day compressive strength. However, added water caused a drop in compressive strength value of about 6 – 7 MPa. Depth of water penetration shows contrary results compared to the following fundamental principle – the higher the water-cement ratio, the worse water-tightness. However, the contradiction could be influenced by the following factors: only one sample per concrete mix was tested, all measured values are relatively small, and the determination of water-tightness is quite sensitive in terms of deviation. The most important fact is that all values are lower than 20 mm, which is usually the most strict requirement.

Table 14 - Differently adapted concrete mixes - concrete properties of hardened concrete

Identification		Hardened concrete		
Strength class	Description	Density [kg/m <sup>3</sup> ]	28-day compressive strength [MPa]	Depth of penetration of water [mm]
C30/37	Reference	2328	51,3	18
-	10l/m <sup>3</sup>	2313	45,2	13
-	20l/m <sup>3</sup>	2300	44,0	5
-	Superplasticizer	2312	50,6	6

Similar behaviour, as at later age strength, is observed in the early-age compressive strength samples. Figure 71 presents calibration curves of all concrete mixes. Compressive strength development of concrete mix with an added superplasticiser (grey line) evinces even faster strength development of about +1 MPa than the reference concrete mix design (orange line). Concrete samples with added water reached significantly lower values of approx. –2 MPa or –4 MPa (light and dark blue lines).

The dashed orange line represents the regression line of the reference concrete mix. This dashed regression line was determined in semi-adiabatic conditions using calibration boxes (similar to the ones shown in Figure 30). The result is quite different compared to the regression line determined at samples at 21°C (Figure 70). The influence of different hardening temperatures is excluded because the appropriate C-value confirmed by the laboratory test was used, and the temperature of all samples was precisely continuously measured. *Note: The topic of C-value is discussed in the next chapter.* The difference of approx. 4 MPa between the regression line from semi-adiabatic conditions (orange dashed line) and 21°C room temperature (orange solid line) is caused by the timing of tests. Because all the tests and activities in the experiment were done predominantly by the author of the thesis, it took about 4 hours. The early-age samples in semi-adiabatic conditions were created right



after the concrete mixing. However, the early-age samples stored at 21°C were made at the end of the experimental work when the properties of hydrated cement in the concrete differed.

Despite the detailed planning upfront, all the activities took longer than expected, especially the proper mixing of adapted concrete batches, which was hard work. This could be considered a failure. On the other hand, it underlines the importance of early pouring of ready-mix concrete – until 90 minutes, as usually stated in the delivery sheet.

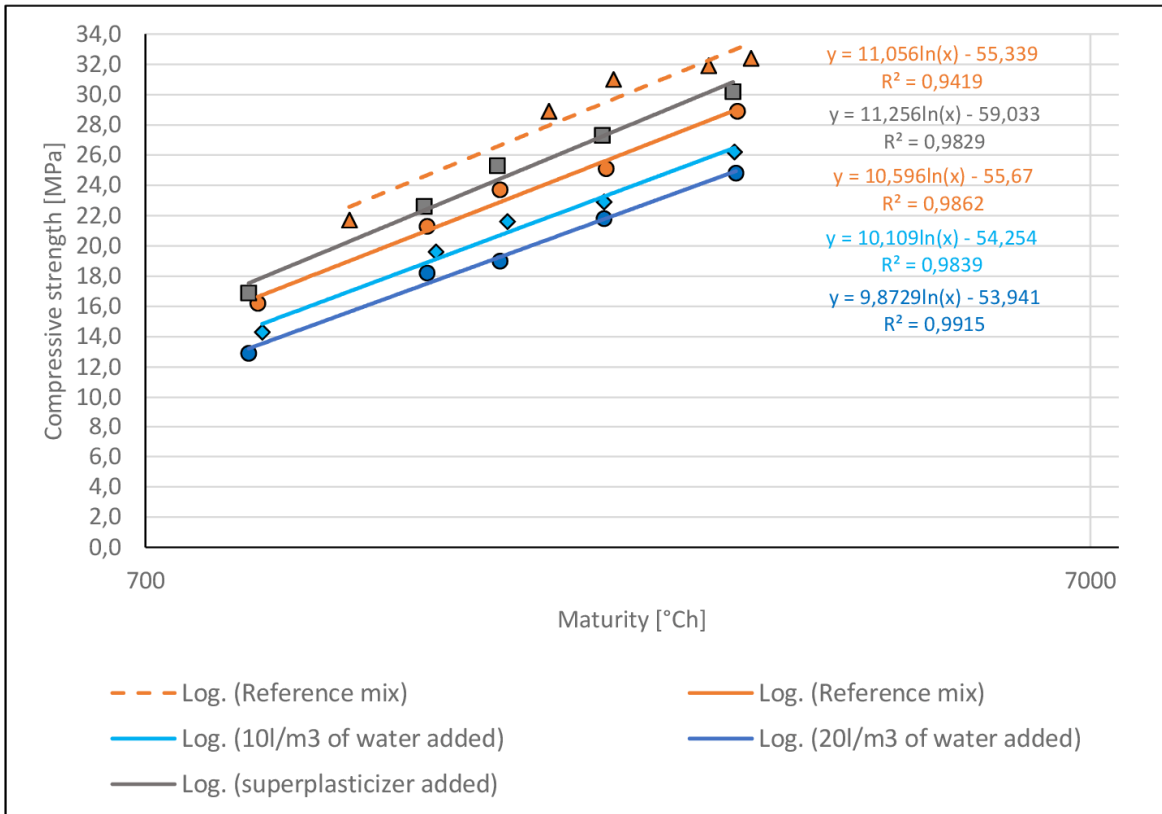

Figure 71 - Differently adapted concrete mixes - regression lines of strength development

### 11.3 Summary

In specific tested cases, the added dosage of 0,4 l/m<sup>3</sup> of superplasticizer reached the same consistency as the added 10 l/m<sup>3</sup> water. However, adding water decreased early-age strength by about 2-2,5 MPa and 28-day strength by about 6 MPa. The superplasticizer improved slightly early-age strength, and 28-day strength was not significantly influenced.

The results showed the negative impact of adding water to ready-mix concrete at the construction site and confirmed the negligible effect of the adaption of concrete mix following the recommended procedure with a superplasticiser. In the case of added water, compressive strength values are affected at an early age and later age.



## 12 C-value determination

The last experimental part deals with determining the C-value and its influence on the accuracy of the maturity method's results. All C-values used in the thesis were initially estimated based on the results provided by cement producers in the Netherlands, with limited probability that those estimations were correct. The need for this practical part arose during previous research, and the author identified the necessity to test the C-value while evaluating validation results. Because the author tended to avoid all deviations of input information, which can influence the accuracy, he decided to perform these laboratory tests to get the most accurate C-values and hands-on experience in this field.

The C-value of cement is considered one of the essential properties, which is usually tested and provided by cement suppliers. However, this works only in countries where the maturity method de Vree is well-known and often used, such as the Netherlands. In countries where this method is not commonly used (e.g. the Czech Republic), people from the cement industry don't even know how to test C-value.

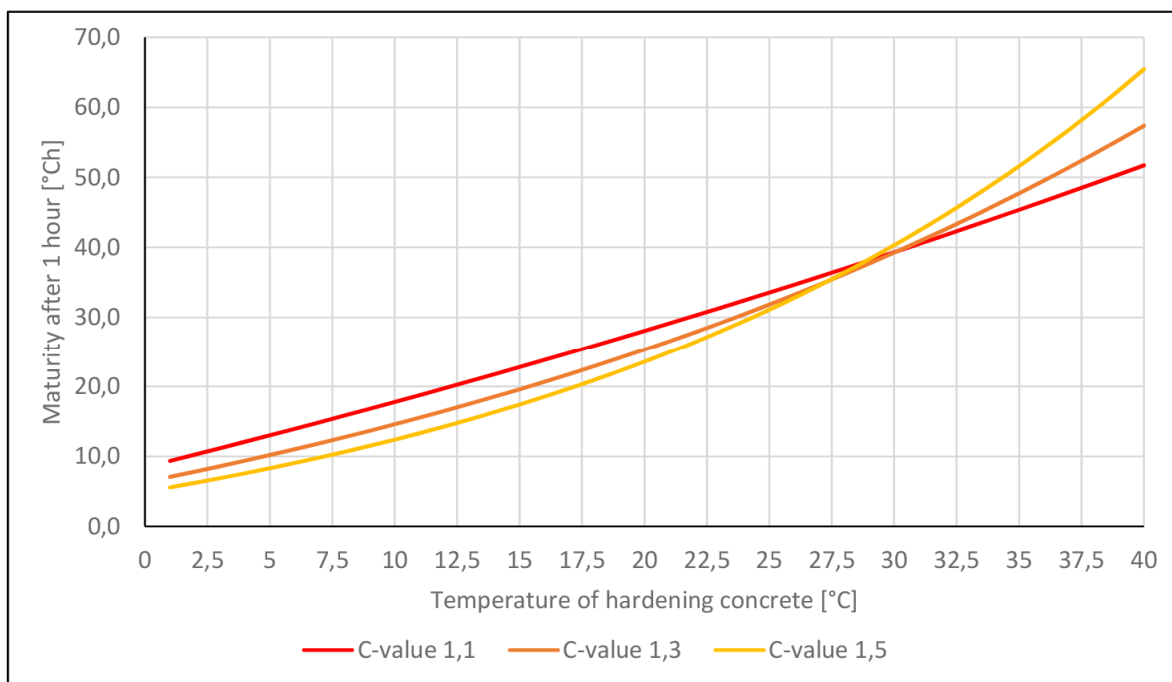

Figure 72 - Maturity gain at different concrete temperature and C-value

As already written in the theoretical part of the thesis (Chapter 5.1.3), C-value represents the temperature sensitivity of cement in the calculation. Before any presentation of the tested results, the behaviour of C-values needs to be explained. Figure 72 illustrates the gains of maturity at different concrete temperatures and C-values. A C-value of 1,1 can typically represent CEM I 52,5R, and a C-value of 1,5 can represent CEM III/B 32,5 N. The curve of C-value 1,1 looks almost like a line, but the curve of C-value 1,5 is curved significantly. In the case of cement with C-value 1,5, the maturity



gains are considerably lower if the concrete temperature is below 20°C compared to maturity gains per hour of cement with C-value 1,1. On the other hand, the trend is opposite above 30°C where the gains are bigger with cement of C-value 1,5. That's the simple consideration of the temperature sensitivity of cement by the C-value. It is also important to mention that around 30°C concrete temperature, all types of cement gain similar maturity.

A possible influence of the appropriate C-value on accuracy at specific concrete temperatures is illustrated in Table 15. For the following investigation, the calibration results of concrete mix design 3W-3R (Chapter 9.3.1) were used with four different C-values (1,2; 1,3; 1,4; 1,5). Table 15 presents maturity and compressive strength calculated using a calibration curve with different C-values at specific constant concrete temperatures during a defined time. The duration was always limited to reach strength close to the target value of 26 MPa and rounded to a whole day. If a concrete sample matures for five days at a concrete temperature of 10°C, the calculated strength using a calibration curve with C-value 1,2 results in 28,4 MPa, while a calibration curve with C-value 1,5 results in 24,1 MPa. It means that if concrete with a cement C-value of 1,5 is used, but a C-value of 1,2 is selected for calculation, it can deliver a deviation of 4,3 MPa at 10°C concrete temperature during five days. If the concrete temperature is 30°C, the influence of the wrongly chosen C-value is insignificant.

The statement cited in Chapter 5.7 claims that the C-value from the literature delivers similar results to the tested C-value. The research, where the information came from, faced differences between tested and founded C-values of about 0,25, which is not insignificant. However, all the tests occurred in the laboratory, and most samples were stored in laboratory conditions at about 25°C, where the difference becomes negligible. As demonstrated in Table 15, wrongly estimated C-value can cause significant deviation at low temperatures. It explains why the author's conclusion differed from that cited research from the literature, where the low-temperature scenario is not included. [60]

Table 15 - Calculated compressive strength using different C-value at a different concrete temperature

Scenario		C-value 1,2		C-value 1,3		C-value 1,4		C-value 1,5		Max. Δ [MPa]
Temp.	Duration [days]	Maturity [°Ch]	Compressive strength [MPa]	Maturity [°Ch]	Compressive strength [MPa]	Maturity [°Ch]	Compressive strength [MPa]	Maturity [°Ch]	Compressive strength [MPa]	
10 °C	5	1923	<b>28,4</b>	1751	<b>27,0</b>	1609	<b>25,5</b>	1489	<b>24,1</b>	<b>4,3</b>
20 °C	3	1909	<b>28,3</b>	1823	<b>27,6</b>	1753	<b>26,8</b>	1697	<b>26,1</b>	<b>2,2</b>
30 °C	2	1877	<b>28,0</b>	1884	<b>28,1</b>	1905	<b>28,1</b>	1935	<b>28,1</b>	<b>-0,1</b>

Because the illustration in Table 15 is only a theoretical approach based on constant concrete temperature, another example of the actual measurement of the validation



sample is shown in Figure 73. It uses the temperature data of the validation sample 3W-3R (Chapter 9.3.2) and calibration data of the related concrete mix design with different C-values.

Calculated results after 70 hours vary from 25,8 MPa to 27,9 MPa. The determined the C-value of the binder was 1,35. Calibration data, in combination with a C-value of 1,35, provides a result of 26,8 MPa. The actual tested compressive strength was 26,1 MPa. The difference between the correctly calculated (26,8 MPa) and the actual result (26,1 MPa) is caused by deviations that occur every time.

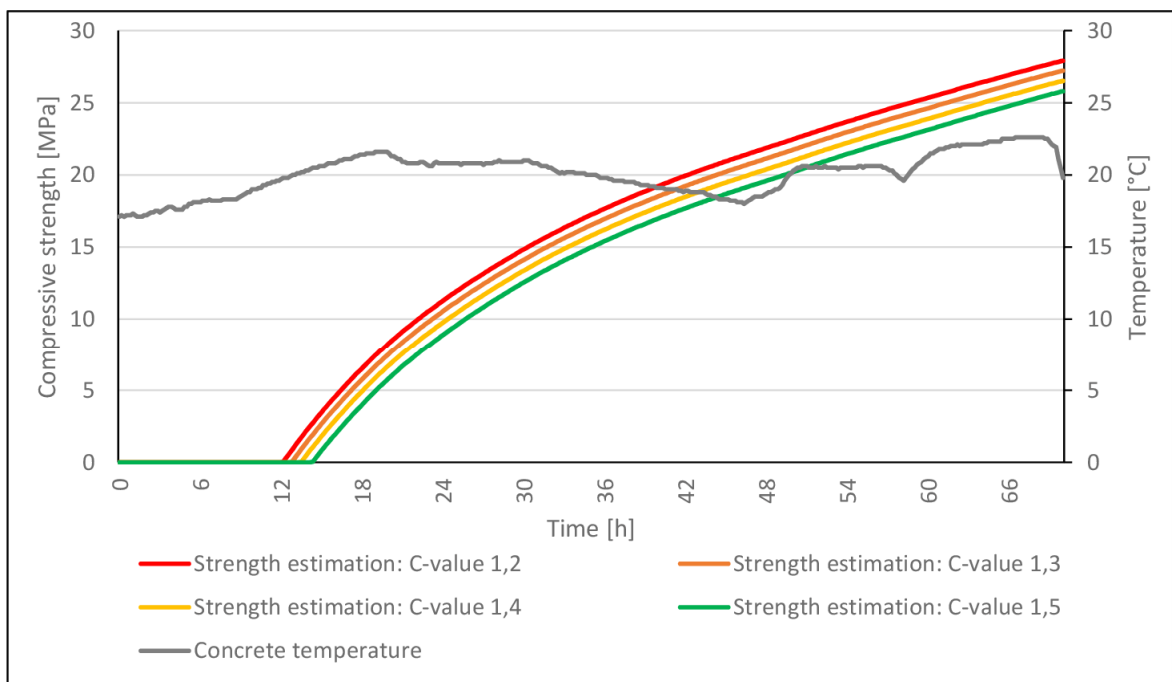

Figure 73 - Validation measurements based on different C-values

## 12.1 Procedure

The whole procedure of C-value determination is specified in NEN 5970 and described in detail in Chapter 5.1.3. The main principle is the determination of the C-value when the compressive strength results of samples stored at 20°C and 65°C correlate the best. The compressive strength tests are performed with halves of mortar prisms acc. EN 196-1. [7; 32]

The following binders used in previous experimental parts were tested:

- CEM I 42,5 R (sampling: 08/22)
- CEM II/B-S 32,5 R (sampling: 08/22)
- CEM II/B-S 32,5 R "old" (sampling: 07/21)
- CEM II/B-S 32,5 R + fly ash (sampling: 08/22)
- CEM III/B 32,5 L (sampling: 08/22)



Figure 74 - Determination of C-value - prisms stored at 20°C (left) and 65°C (right), [photo: author]

It consists of three selected cement types. In the case of CEM II/B-S, two batches were tested, one from 08/22 and another from 07/21 – the batch which remained from the second experiment part. CEM II/B-S was also tested with fly ash because fly ash was used as an addition in most concrete mix designs. The mixing proportion is 83,7% of CEM II/B-S and 16,7% of fly ash, similar to tested concrete concrete mix designs.

## 12.2 Results

Table 16 shows the initially estimated C-values and experimentally determined C-values in the laboratory. The biggest difference between estimation and test is 0,1, which is insignificant but worth adapting and making the results more precise. All above-presented results in previous chapters were already recalculated using experimentally determined C-values.

Table 16 - C-values of used types of cement

Cement type	C-value	
	estimated	tested
CEM I 42,5 R	1,20	1,30
CEM II/B-S 32,5 R	1,30	1,30
CEM II/B-S 32,5 R "old"	1,30	1,30
CEM II/B-S 32,5 R (83,3%) + fly ash (16,7%)	1,30	1,35
CEM III/B 32,5 L	1,50	1,60

## 12.3 Summary

Appropriate estimation of the C-value can be sufficient for the use of the maturity method. Special attention should be paid if the concrete hardens at low temperatures because a lower C-value (compared to the actual one) could underestimate



---

the strength result. Laboratory determination of C-value gives precision to strength results. However, if the temperature of hardening is not low, the difference is not significant.

The estimation of C-values of Czech cement, which the author made based on data from Dutch cement suppliers, was not much different from the tested results. The biggest difference was 0,1, which is not significant if the temperature during hardening is not too low. In total, 24 mortar mixes were mixed, and 144 halves of prisms were tested. Due to the experience of strength development of those cement types from the second experimental phase and detailed planning, the number of samples could be smaller because the hardening speed was well predicted and tests performed at the right time.



## 13 Conclusion

The thesis aimed to get more insights into **the influences of concrete mix design changes and common deviations on the calibration curve of the maturity method**, which represents the compressive strength development of concrete and is a basis for nondestructive monitoring of early-age strength. The topic has recently become more critical because the number of commercial systems that use the maturity method is increasing due to advancing digitalization in construction and constant time pressure in construction projects. The need is supported by reducing clinker content in cement, which is one measure of ambitious plans for decarbonizing the cement industry.

The overview of frequent changes in a concrete mix composition and their impact on the calibration curve can reduce the effort during the calibration process, the number of performed calibrations, and unsuccessful tries during the implementation of the maturity method. The outcome is an up-to-date analysis from practice, representing a common situation at the concrete supplier and construction site, including all deviations in practice. It is the crucial distinction compared to most other theses in this field, usually done in the laboratory.

Tested mortar and concrete samples indicate the extent of the whole research. The compressive strength of almost 650 halves of the cement prisms and nearly 250 concrete cubes were tested.

Extensive experimental research has proven that the maturity method is applicable in practice also in local conditions of the Czech republic. The most important parameters influencing the early compressive strength of concrete were identified and their effect was evaluated. The influence of changes in concrete composition on the calibration curve of the maturity method were identified and quantified. Recommendations for application of the maturity method are discussed at the ends of individual chapters and the recommended values the safety factor were considered as appropriate.

### 13.1 Effects of specific concrete mix design changes

Before the concrete tests took place, various changes in the mix design were tested at the cement mortar level to prepare a basis for further concrete tests. A general advantage of cement mortar is a reduced need for material and the possibility of executing many tests. This extensive experimental analysis determined a plan for concrete tests at a less accurate research environment (concrete plant and construction site). **The effects of specific concrete mix design changes on compressive strength development** were investigated at the concrete supplier with ready-mix concrete.

- **Cement type**

Change in cement type and noticeable increase or decrease in cement amount ( $\pm 50 \text{ kg/m}^3$ ) influence the compressive strength of concrete significantly. The different

cement amounts (310, 360, 410 kg/m<sup>3</sup>) proportionally changed strength development in the investigated calibration range. An increase of 50 kg/m<sup>3</sup> of cement resulted in faster strength development of about 6 MPa compared to a lower dosage (Figure 56).

A comparison of the same cement type from two producers is not easy to test in practice due to the necessary availability of both cement products at one concrete plant, which is not very realistic. This comparison was performed only using cement mortar. The same types of cement from two various productions provided slightly different but comparable results. However, it is also vital to emphasise that those two productions belong to one company. Based on the author's practical experience, the same cement types from different producers and countries can deliver different results.

The change in cement could always make a big difference (Figure 55) to the calibration curve, and a new calibration is recommended. The only exception could be a change in cement amount of about 10-15 kg/m<sup>3</sup>, where a new calibration is not necessary.

- **Water-cement ratio and superplasticizer**

The first investigation with cement mortar confirmed a significant influence of the water-cement ratio on compressive strength development, and a positive influence of superplasticizer on compressive strength development was observed. This complies with the principles of concrete technology. Reduction of water content in combination with superplasticizer resulted in significantly faster strength development (+6,5 MPa) compared to standard cement mortar acc. EN 196-1.

During the investigation of concrete mix design changes at the concrete plant, mix designs were always designed efficiently, which means that the water content and the dosage of superplasticizer of all mix designs were optimised in compliance with the basic principles of concrete technology.

The influence of water content was tested in relation to adding water to fresh concrete, which simulates a common issue in practice with adding water to the concrete truck to reach better consistency and workability. That kind of investigation was initiated based on the observation of the unprofessional adaption of a concrete mix by added water, which was often noticed during sampling on the construction site.

During the research, water or superplasticizer was additionally added to the concrete by purpose, and the results were the following (Figure 71). In specific tested cases, the added dosage of 0,4 l/m<sup>3</sup> of superplasticizer improved the consistency the same as the added 10 l/m<sup>3</sup> water. However, adding water decreased early-age strength by about 2-2,5 MPa and 28-day strength by about 6 MPa. The superplasticizer improved slightly early-age compressive strength (+2 MPa), and 28-day strength was not significantly influenced. It confirmed the negligible effect of the adaption of concrete mix following the recommended procedure with a superplasticiser.

If a noticeable amount of water (> 7 l/m<sup>3</sup>) is added to the concrete, the existing calibration curve is not reliable anymore.



- **Aggregates**

Modifying the grain-size curve in the concrete mix designs visibly affects the compressive strength within 4 MPa (Figure 58). It emphasizes the importance of sand as a local material and the importance of calibrating concrete. Cement mortar tests of different samples of sand from other quarries confirmed a considerable impact of sand on early-age compressive strength and strength in general.

Adapting the concrete mix design for a smaller maximum grain size (from 22 mm to 16 mm) usually requires other minor changes, especially an increase in cement amount (+10 kg/m<sup>3</sup>) and superplasticizer. All changes cause a slight decrease in strength development of about 1 – 2 MPa (Figure 59).

Whenever the source of sand is changed, a new calibration is recommended. If two alternatives of the mix designs with  $D_{\max}=22$  mm and 16 mm are used, one calibration curve is sufficient. The concrete mix design with  $D_{\max} = 16$  mm is preferred for calibration because the developed calibration curve will only slightly underestimate the estimated results for the mix design with  $D_{\max} = 22$  mm. This question was very often asked in practice.

- **Admixtures**

Besides the use of a superplasticizer, admixtures for shortening the workability and accelerating the setting time were investigated. Standard winter measures using their different combinations to accelerate a concrete setting do not significantly influence the early-age strength within the analysed range = around 70% of 28-day compressive strength (Figure 60).

The use of a hardening accelerator, which could have a significant influence, was not tested because it is a topic of individual research.

- **Additions**

Two common concrete additions were used in concrete mix designs – fly ash and limestone. Fly ash substitution for limestone results in a visible drop of approximately 3 MPa, especially in later ages (Figure 59).

Based on the results of performed tests, the following measures **could significantly influence calibration curve** = compressive strength development: change of cement type, a significant change of cement amount (>10-15 kg/m<sup>3</sup>), change of cement supplier, considerable adaption of water content and used superplasticizers, use of sand from different quarry. Substitution of concrete addition could have less significant influence, but it needs to be evaluated in particular cases.

**Insignificant changes in compressive strength development** have the redesigning of the concrete mix design for smaller maximum grain size and winter measures of adapted workability and accelerated setting.

Since concrete consists primarily of natural materials, recalculating the calibration curve based on experience with another concrete mix design is not recommended because a calculation result could deviate from reality. However, the results of the tests summarised above could provide a good orientation for handling changes in the concrete mix design.

## 13.2 Deviations in practice

All performed experimental analyses confirmed that the maturity method documents the changes in the mix design well, and the differences are clearly visible. From a linear regression point of view, maturity and strength correlate very well because the **coefficient of determination of all curves has not dropped under  $R^2 = 0,96$** .

Five repeated calibrations of the same concrete mix design during one and half months provided four similar calibration lines and one line with significantly lower strength values. The drop in compressive strength was also observed in regular tests (such as 7-day and 28-day specimens), which could be an excellent hint to identify the deviation in practice. In this particular case, the main reason was probably the deviation in the fly ash quality.

Regularly performed thirteen validations on the construction site confirmed that the maturity method allows the safe determination of compressive strength on the construction site because most of the validations were successful (Figure 67 and Figure 68). In detail, ten validations provided results within the range of safety factors (acc. NEN 5970). One validation resulted in a slightly lower strength value not fully covered by the safety factor, but the deviation was not significantly higher than the safety factor (0,7 MPa below the range of safety factor). Adding water to the concrete affected two validations, resulting in lower strength results.

The last experimental part confirmed that an appropriate estimation of the C-value can be sufficient for using the maturity method. Special attention should be paid to concrete, which hardens at low temperatures because a lower C-value (compared to the actual one) could underestimate the strength result.

## 13.3 Limitations

Most of the tests were executed by the author for two main reasons exclusively. The first goal was to minimise the variations by having just one laboratory technician = author of the thesis. The second aim was to get more hands-on experience and skills, which is much more enriching than just receiving the results without involvement.

During the execution of the experiments, close attention was paid to compliance with European standards and to the reduction of deviations related to unqualified and inconsistent execution of laboratory tests. Cement and cement mortar tests were performed according to EN 196-11 and EN 196-1. Concrete tests complied with EN 206+A2



and with a group of standards for testing fresh concrete EN 12350 and hardened concrete EN 12390. Utilization of the maturity method followed the requirements of the Dutch standard NEN 5970.

Because concrete was mixed from local materials in the Czech Republic, the broader interpretation of results needs to be careful.

### **13.4 Recommendation for further research**

The experimental work contains the results of today's standard concrete mix design. Due to the strong demand for CO<sub>2</sub> reduction in the concrete industry, clinker content in cement is reduced, or additions substitute a higher amount of cement. Both measures result in significantly slower strength development, which also increases the time of calibration of the concrete mix design up to 2,5 weeks. The question is how reliable the calibration curves of such concrete mixes can be.

The addition of a hardening accelerator was not part of the investigation. Hardening accelerators could be an essential ingredient of concrete in the future. The goal is to find a good relation between the positive effect, moderate CO<sub>2</sub> footprint and acceptable price increase of the concrete mix. This topic is worth digging into. The maturity method could also help in that kind of research.



# Bibliography

- [1] COLLEPARDI, Mario. *The New Concrete*. 2nd. Lancenigo, Italy: Grafiche Tintoretto, 2010. ISBN 9788890377723.
- [2] AITCIN, Pierre-Claude. *High Performance Concrete: Modern Concrete Technology*. 1st. United States: CRC Press, 1998. ISBN 9781135823573.
- [3] *Maturity Methods to Estimate Concrete Strength*. 1. Maryland: National Ready Mixed Concrete Association, 2006.
- [4] MALHOTRA, V. a Nicholas CARINO. *Handbook on nondestructive testing of concrete*. 2nd ed. Boca Raton, Fla.: CRC Press, 2004. ISBN 08-031-2099-0.
- [5] *Decarbonising Cement and Concrete: A CO<sub>2</sub> Roadmap for the German cement industry*. 1st. Duesseldorf, Germany: Verein Deutscher Zementwerke, 2020.
- [6] SPAUN, Sebastian, Cornelia BAUER, Claudia DANKL, Rupert FRIEDLE a Felix PAPSCH. *Roadmap zur CO<sub>2</sub>-Neutralität der österreichischen Zementindustrie bis 2050: Wie Was Wenn*. 1st. Wien: Vereinigung der Österreichischen Zementindustrie (VÖZ), 2020.
- [7] NEN 5970. *Determination of the compressive strength development of early age concrete on the basis of the weited maturity*. 1. Netherlands: Dutch Standard, 2001.
- [8] C1074 - 04. *Standard Practice for Estimating Concrete Strength by the Maturity Method*. United States: ASTM International, 2004.
- [9] BERGINZ, Jürgen. *Bewertung von Beton-Reifegradmodellen zur Abschätzung des Temperatureinflusses auf der Festigkeitsentwicklung*. Innsbruck, 2017. Masterarbeit. Leopold-Franzens-Universität Innsbruck. Vedoucí práce Andreas Saxer.
- [10] NIXON, Jeffery, Anton SCHINDLER, Robert BARNES a Samuel WADE. *Evaluation of the Maturity Method to Estimate Concrete Strength in Field Applications*. Alabama, 2008. Research Report. Auburn University.
- [11] PALFRADER, Luca a Hannes SEEHAUSER. *Vergleich unterschiedlicher Reifemethoden auf ihren baupraktischen Einfluss unter Berücksichtigung variierender Expositionen*. Innsbruck, 2018. Masterarbeit. Universität Innsbruck. Vedoucí práce Dipl.-Ing. Dr. Christoph Niederegger, BSc. MSc. Michael Schmade.
- [12] NEHDI, Moncef a Ahmed SOLIMAN. Early-age properties of concrete: Overview of fundamental concepts and state-of-the-art research. In: *Proceedings of the Institution of Civil Engineers*. London, UK: ICE Publishing, 2009, Paper 900040.
- [13] WINSKELL, Jacob, Robert MCCAFFREY, ed. *Global Concrete Report 2021*. Preview. Epsom, Surrey, UK: Pro Global Media Ltd, 2021.



- [14] PAVLÍKOVÁ, Milena, Zbyšek PAVLÍK a Jiří HOŠEK. *Materiálové inženýrství I. 2.*, přeprac. vyd. V Praze: České vysoké učení technické, 2011. ISBN 978-800-1049-327.
- [15] LEHNE, Johanna a Felix PRESTON. *Making Concrete Change: Innovation in Low-carbon Cement and Concrete* [online]. 1st. London: The Royal Institute of International Affairs, 2018 [cit. 2023-01-04]. ISBN 9781784132729.
- [16] EN 197-1. *Cement: Part 1: Composition, specifications and conformity criteria for common cements*. Brussels: European Committee for Standardization, 2011.
- [17] EN 197-5. *Cement - Part 5: Portland-composite cement CEM II/C-M and Composite cement CEM VI*. 1st. Brussels: European Committee for Standardization, 2021.
- [18] EN 197-6. *Cement - Part 6: Cement with recycled building materials*. 1st. Brussels: European Committee for Standardization, 2022.
- [19] Portlandské směsné cementy - cesta k udržitelnému rozvoji: Portland Composite Cements - The Way to Sustainable Development. *Beton TKS*. Prague: Beton TKS, s.r.o., 2021, (1), 4-14. ISSN 1213-3116.
- [20] *Reduction of greenhouse gas emissions in cement and concrete production*. 1st. Prague: Czech cement association, 2022.
- [21] *Market share of cement types in Czech Republic*. 1st. Prague: Czech cement association, 2021.
- [22] *Zementindustrie im Überblick*. 1st. Düsseldorf: Verein Deutscher Zementwerke, 2022.
- [23] PYTLÍK, Petr. *Technologie betonu*. 2. vyd. Brno: VUTIUM, 2000. Učebnice (VUTIUM). ISBN 80-214-1647-5.
- [24] SMEPLASS, Sverre a Egil MØEN, Stefan JACOBSEN. *TKT 4215 Concrete Technology 1*. 1st translation. Norway: Skanska Norge AS, 2003.
- [25] SCRIVENER, Karen a André NONAT. Hydration of cementitious materials, present and future. *Cement and Concrete Research*. 2011, **41**(7), 651-665. ISSN 00088846. Dostupné z: doi:10.1016/j.cemconres.2011.03.026
- [26] SCRIVENER, Karen, Alexandre OUZIA, Patrick JUILLAND a Aslam KUNHI MOHAMED. Advances in understanding cement hydration mechanisms. *Cement and Concrete Research*. 2019, **124**. ISSN 00088846. Dostupné z: doi:10.1016/j.cemconres.2019.105823
- [27] SCRIVENER, Karen, Patrick JUILLAND a Paulo MONTEIRO. Advances in understanding hydration of Portland cement. *Cement and Concrete Research*. 2015, **78**, 38-56. ISSN 00088846. Dostupné z: doi:10.1016/j.cemconres.2015.05.025
- [28] EN 13791. *Assessment of in-situ compressive strength in structures and precast concrete components*. Brussels: European Committee for Standardization, 2019.
- [29] EN 196-8. *Methods of testing cement: Part 8: Heat of hydration - Solution method*. Brussels: European Committee for Standardization, 2010.

- [30] EN 196-9. *Methods of testing cement: Part 9: Heat of hydration - Semi-adiabatic method*. Brussels: European Committee for Standardization, 2010.
- [31] EN 196-11. *Methods of testing cement: Part 11: Heat of hydration - Isothermal Conduction Calorimetry method*. Brussels: European Committee for Standardization, 2018.
- [32] EN 196-1. *Methods of testing cement: Part 1: Determination of strength*. Brussels: European Committee for Standardization, 2005.
- [33] KASAL, Pavel a Martin KEPPERT. Měření hydratačního tepla cementu: Determination of the Heat of Hydration of Cement. *Beton TKS*. Prague: Beton TKS, s.r.o., 2022, 68-71. ISSN 1213-3116.
- [34] TAM Air *Isothermal calorimetry: Information booklet*. 1st. USA: TA Instruments/Waters Corporation, 2020.
- [35] EN 206+A2. *Concrete - Specification, performance, production and conformity*. Brussels: European Committee for Standardization, 2021.
- [36] HELA, Rudolf. Příměsi do betonu: Concrete Additions. *Beton TKS*. Prague: Beton TKS, s.r.o., 2015, 4-10. ISSN 1213-3116.
- [37] ČSN P 73 2404. *Beton - Specifikace, vlastnosti, výroba a shoda - Doplnující informace*. Prague: Úřad pro technickou normalizaci, metrologii a státní zkušebnictví, 2022.
- [38] ÖNORM B 4710-1. *Beton - Festlegung, Eigenschaften, Herstellung, Verwendung und Konformität*. Wien: Austrian Standards, 2018.
- [39] TÁBORSKÝ, Tomáš a Vladimír VESELÝ. Popílek - Aktuální stav tradiční příměsi do betonu: Fly Ash - Current State of Traditional Concrete Additive. *Beton TKS*. Prague: Beton TKS, s.r.o., 2021, (1), 24-27. ISSN 1213-3116.
- [40] LÖFGREN, Ingemar. New binders – what happens now and in the future?. In: *Binders and concrete for the next decade*. Webinar: ECSN, 2023.
- [41] EN 13670. *Execution of concrete structures*. Brussels: European Committee for Standardization, 2009.
- [42] ACI 306. *Guide to Cold Weather Concreting*. USA: American Concrete Institute, 2016.
- [43] KLEČKA, Tomáš, Vladimír VESELÝ, Stanislav SMIŘINSKÝ, Václav BLÍŽKOVSKÝ a Lukáš PEŘEK. *Příručka technologa: Suroviny - výroba - vlastnosti*. 1. aktualizované. Praha: Českomoravský beton, 2013.
- [44] EN 12390-3. *Testing hardened concrete: Part 3: Compressive strength of test specimens*. Brussels: European Committee for Standardization, 2019.
- [45] EN 12350-1. *Testing fresh concrete: Part 1: Sampling and common apparatus*. Brussels: European Committee for Standardization, 2019.
- [46] EN 12390-2. *Testing hardened concrete: Part 2: Making and curing specimens for strength tests*. Brussels: European Committee for Standardization, 2019.



- [47] ASTM C873. *Standard Test Method for Compressive Strength of Concrete Cylinders Cast in Place in Cylindrical Molds*. ASTM, 2016.
- [48] CIKRLE, Petr, Petr MISÁK, Tereza KOMÁRKOVÁ, Ondřej ANTON a Petr DANĚK. *Nedestruktivní metody ve stavebním zkušebnictví*. Brno: Vysoké učení technické, 2021.
- [49] CIKRLE, Petr a Dalibor KOCÁB. Rebound Hammer Testing of Concrete - Part I. *Beton TKS*. Prague, 2018, (6), 45-47.
- [50] CIKRLE, Petr, Dalibor KOCÁB a Josef ČERVENKA. Rebound Hammer Testing of Concrete - Part II. *Beton TKS*. Prague, 2019, (2), 14-18.
- [51] *The Original SCHMIDT fully integrated electronic concrete test hammer*. 1st. Switzerland: Proceq SA, www.proceq.com, 2007.
- [52] KOCÁB, Dalibor, Petr CIKRLE a Petr MISÁK. Rebound Hammer Testing of Concrete - Part III. *Beton TKS*. Prague, 2019, (5), 42-47.
- [53] EN 12504-4. *Testing concrete in structures: Part 4: Determination of ultrasonic pulse velocity*. Brussels: European Committee for Standardization, 2021.
- [54] DIN 1045-3. *Tragwerke aus Beton, Stahlbeton und Spannbeton - Teil 3: Bauausführung*. Berlin: Deutsches Institut für Normung, 2023.
- [55] DESIK, Fatih a Ilker USTABAS. Use of Weight Maturity Method for Building Concretes Used in Artvin Yusufeli Dam Construction. *Cement Based Composites*. 2019, (1), 1-5.
- [56] MAIER, Gerald, Martin PEYERL a Stefan KRISPEL. *Nachweis der realen Frühfestigkeit am Bauwerk*. Vienna, Austria, 2015. FFG Projekt. TU Wien.
- [57] SCHMID, Michael, Christian PICHLER, Alexander REINISCH, Andreas SAXER a Roman LACKNER. Prognose der temperaturabhängigen Festigkeitsentwicklung in Betonbauteilen. *Bauingenieur*. Germany, 2018, 214-222.
- [58] EN 1015-3. *Methods of test for mortar for masonry: Part 3: Determination of consistence of fresh mortar (by flow table)*. Brussels: European Committee for Standardization, 1999.
- [59] EN 12350-2. *Testing fresh concrete: Part 2: Slump-test*. Brussels: European Committee for Standardization, 2019.
- [60] EN 12350-6. *Testing fresh concrete: Part 6: Density*. Brussels: European Committee for Standardization, 2019.
- [61] EN 12350-7. *Testing fresh concrete: Part 7: Air content - Pressure methods*. Brussels: European Committee for Standardization, 2019.
- [62] ČSN 73 1332. *Stanovení tuhnutí betonu: Determination of concrete setting time*. Praha: Úřad pro technickou normalizaci, metrologii a státní zkušebnictví, 1986.
- [63] KASAL, Pavel a Werner WENIGHOFER. *Efficient Project Execution with Low Carbon Concrete*. Zakopane: The 13th Central European Congress on Concrete Engineering, 2022.



- 
- [64] KASAL, Pavel a Jan VÍTEK. *Influence of Concrete Mix Composition on the Early Age Concrete Strength Development* [online]. Rome: fib - The International Federation for Structural Concrete, 2022 [cit. 2023-03-06]. ISBN 978-294064317-2. ISSN 26174820.
- [65] EN 12504-2. *Testing concrete in structures: Part 2: Non-destructive testing - Determination of rebound hammer*. Brussels: European Committee for Standardization, 2017.
- [66] *Concrete Test Hammer: Operating Instructions*. Switzerland: Proceq SA, [www.proceq.com](http://www.proceq.com), 2002.
- [67] ČSN 73 1373. *Non-destructive testing of concrete: Determination of compressive strength by hardness testing methods*. Prague: Česká agentura pro standardizaci, 2011.



## List of figures

Figure 1 - Market share of cement types in Austria [6], Czech Republic [21] and Germany [22] in 2020 .....	15
Figure 2 - Hydration heat development of cement CEM I 42,5 R [scheme: author] .....	17
Figure 3 – Development of heat of hydration - CEM I 42,5 R [graph: author] .....	18
Figure 4 - Compressive strength development - CEM I 42,5 R [graph: author] .....	18
Figure 5 - Scheme of the isothermal conduction calorimetry test [scheme: author] ..	21
Figure 6 - Samples + reference samples (left), Calorimeter including the samples (right) [photo: author] .....	21
Figure 7 - Compressive strength development using hardening accelerator at 20°C [graph: author] .....	24
Figure 8 – Cement and additions: limestone, blast furnace slag, fly ash, cement (II/B-S) [photo: author] .....	25
Figure 9 – Insulation of wall formwork (left), Heating of concrete with disposable cables (right) [Photo: R. Björkman, I. Beliatskli] .....	31
Figure 10 - Covered window openings of the heated storey (left), finishing of concrete works in Finland (right) [Photo: author] .....	32
Figure 11 - Temperature development during the use of gas heating in Finland [graph: author] .....	33
Figure 12 – Heated formwork in use (left), concrete pouring into the heated formwork in Finland (right) [Photo: author] .....	33
Figure 13 - Temperature and compressive strength development while using heated formwork [graph: author] .....	34
Figure 14 - Cube sampling on the construction site [photo: author] .....	37
Figure 15 - The influence of curing temperature on compressive strength (cube vs. slab) [graph: author] .....	38
Figure 16 - Compressive strength test (left), structure after cores drilling (right) [photo: author] .....	40
Figure 17 - Scheme of ordinary rebound hammer Schmidt N [scheme: author] .....	41
Figure 18 - Schmidt N, SilverSchmidt N, SilverSchmidt L with mushroom plunger [photo: author], testing anvil [51] .....	42
Figure 19 - Ultrasonic instrument - scheme and picture [picture: author] .....	43
Figure 20 - Principle of maturity method [scheme: author] .....	45
Figure 21 - Example of calibration curve [scheme: author] .....	46
Figure 22 - Range of possible use of maturity method [scheme: author] .....	46
Figure 23 - Nurse-Saul: a principle of calculation [scheme: author] .....	48
Figure 24 - Typical values of age conversion factor [scheme: author] .....	49
Figure 25 - Typical values of activation energy [scheme: author] .....	49
Figure 26 - Example of iteration during C-value determination of CEM II/B-S 32,5 R [graph: author] .....	51
Figure 27 – Example of calibration process according to NEN 5970 [scheme: author] .....	52

Figure 28 - Comparison of samples needed for calibration according to NEN and ASTM [scheme: author].....	53
Figure 29 - Principle of measurement of compressive strength using maturity method [scheme: author].....	55
Figure 30 - Example of calibration box, before pouring (left), after pouring (right), [photo: author].....	57
Figure 31 - Maturity-strength relationship (de Vree), maturity in logarithmic scale [scheme: author].....	58
Figure 32 - Isothermal calorimetry test, cement mortar tests, calibrations at concrete plant [photo: author].....	60
Figure 33 - Validations on the job site, water-cement ratio test, determination of C-value [photo: author].....	60
Figure 34 - Heat of hydration of different cement types, tested at 20°C.....	63
Figure 35 - Heat of hydration of different cement types at 20°C and 25°C.....	64
Figure 36 - Heat of hydration of CEM II/B-S 32,5 R + fly ash, tested at 20°C.....	65
Figure 37 - Plastic bag of standard sand in accordance with EN 196-1 [photo: author].....	68
Figure 38 - Amount of test samples per mortar mix design and related tests [scheme: author].....	70
Figure 39 - Mixing of cement mortar, flow cone test, sampling [photo: author].....	71
Figure 40 - Curing, flexural strength test, compressive strength test [photo: author].	72
Figure 41 - Comparison of different cement types, use of superplasticizer and setting accelerator .....	73
Figure 42 - Compressive strength development of selected mortar mix designs at mortar temperature of 15°C, 25°C.....	73
Figure 43 - Comparison of cements from two different cement plants.....	74
Figure 44 - Comparison of repeated calibration .....	75
Figure 45 - Comparison of different cement amount and use of additions.....	76
Figure 46 - Comparison of different water-cement ratio, use of superplasticizer.....	77
Figure 47 - Comparison of different type of sand.....	77
Figure 48 - Different type of sand, including validation samples.....	78
Figure 49 - Used types of sand in experiments.....	79
Figure 50 - Grain-size curve of used sand .....	79
Figure 51 - Deviations of validation samples .....	81
Figure 52 - Batching of the concrete before testing [photo: author].....	86
Figure 53 - Slump test, determination of density, air content [photo: R. Syka].....	87
Figure 54 - Determination of w-c ratio, concrete calibration, validation samples [photo: author, R. Syka].....	87
Figure 55 – Comparison of compressive strength development - three cement types .....	89
Figure 56 – Comparison of compressive strength development - different cement amount .....	90
Figure 57 - Grain size curve of used sand .....	91



Figure 58 - Comparison of compressive strength development – three grain size curves..... 92

Figure 59 - Comparison of compressive strength development - smaller  $D_{max}$ , additions (fly ash, limestone)..... 93

Figure 60 - Comparison of compressive strength development - shortened workability, setting accelerator..... 94

Figure 61 – Development of penetration resistance ..... 95

Figure 62 - Results of validation - box plot..... 96

Figure 63 - Repeated calibration of the same concrete mix design..... 99

Figure 64 - Prepared samples (left), curing conditions and monitoring (right) [photo: author]..... 102

Figure 65 - Calibration curves of tested concrete mix designs..... 103

Figure 66 - Sampling dates, ambient temperature and fresh concrete temperature ..... 103

Figure 67 – Validation results performed on the construction site – winter concrete mix..... 104

Figure 68 - Validation results performed on the construction site - summer concrete mix..... 105

Figure 69 - Preparation of concrete batches, three concrete batches before adaption [photo: author]..... 107

Figure 70 - Mixing of adapted concrete batches, early-age compressive strength samples [photo: author]..... 107

Figure 71 - Differently adapted concrete mixes - regression lines of strength development..... 110

Figure 72 - Maturity gain at different concrete temperature and C-value..... 111

Figure 73 - Validation measurements based on different C-values ..... 113

Figure 74 - Determination of C-value - prisms stored at 20°C (left) and 65°C (right), [photo: author]..... 114

Figure 75 - Regression curve provided by manufacturer of Schmidt N [54], testing anvil [51]..... 132



## List of tables

Table 1 – Simplified overview of cement types acc. EN 197-1 and EN 197-5.....	14
Table 2 - Clinker minerals [23; 24] .....	15
Table 3 - Comparison of 28-day samples cured at different conditions .....	39
Table 4 - Results of isothermal calorimetry tests - overview .....	63
Table 5 - Comparison of hydration heat development at 20°C and 25°C.....	65
Table 6 - Description of cement mortar mix designs.....	69
Table 7 - Consistency and 28-day compressive strength of cement mortar mix designs .....	80
Table 8 – Deviations of validation samples .....	82
Table 9 - Results of validation samples .....	96
Table 10 - Results of fresh concrete tests.....	97
Table 11 - Results of hardened concrete .....	98
Table 12 - Results of tests - repeated calibration.....	100
Table 13 - Differently adapted concrete mixes – fresh concrete properties.....	108
Table 14 - Differently adapted concrete mixes - concrete properties of hardened concrete .....	109
Table 15 - Calculated compressive strength using different C-value at a different concrete temperature.....	112
Table 16 - C-values of used types of cement.....	114



# Appendixes

Appendix 1 – Rebound Hammer: Measuring and regression relationship

Appendix 2 – Overview of results – Concrete calibrations

Appendix 3 – Overview of results – Concrete validations

## Appendix 1 - Rebound Hammer

### Measuring and Regression relationship

Schmidt hammers are used to determine compressive strength on the construction site, in the laboratory, or during the inspection of existing structures. According to European standard EN 12504-2, the measurement procedure is the following. Before the beginning of the measurement, the rebound hammer should be validated with a minimum of five rebounds at the testing anvil (Figure 18). The testing anvil is a steel cylinder with a diameter of approximately 150 mm and a weight of about 16 kg, which has a guide pipe for ensuring the vertical position of the Schmidt hammer during the validation. Validation measurement at the testing anvil should evince maximal deviation according to standard  $\pm 3$  rebound numbers from the value specified by the manufacturer. After successful validation measurement, the measurement of the concrete can be started. At least nine rebound readings need to be done with a minimum distance of 25 mm from each other and from the edge to get reliable information about the hardness of an investigated surface of a structure. Each imprint of the plunger should be visually checked if the surface layer is not crushed and the pore or cavity does not negatively influence the result. [28; 48; 52]

The preliminary result of the test is the mean value of all nine mentioned rebound readings. For the validity of the result, the deviation of all readings from the mean value needs to be checked. If more than 20% of rebound readings deviate more than 30% from the mean value, the whole testing has to be executed again. A practical recommendation is to perform ten rebound readings instead of the mandatory nine rebound readings. If two of them do not meet the requirement of the standard and deviate more than 30% from the mean value, the remaining eight readings can still be used. [48; 52]

When the measurements are finished, the rebound hammer should be again validated at the testing anvil. Because the testing anvil is pretty heavy for use on the construction site, the manufacturer offers a smaller alternative of the testing anvil for validation in the field. This smaller anvil does not substitute the standard one. If the small anvil is used on the construction site, a standard one should be used afterwards for confirmation, e.g. after the return to the laboratory. [48]

It is necessary to focus on the tested surface in detail when the rebound hammer is used. The surface should be smooth and eventually brushed to avoid the deviations of decreased rebound values because of crushing the coarse surface of the concrete. The moisture of the concrete surface should be considered because it can also influence the result. [52]

The evaluation's last step is converting the rebound value to compressive strength estimation. The general regression curves are not recommended if the rebound hammer is used to estimate the early-age strength of today's concrete mixes. An example

could be one of the curves provided by the manufacturer with Schmidt N in operating instructions (Figure 75). This relationship was determined many years ago and represented concrete mixtures from the sixties of the last century. Since then, massive development in concrete technology has taken place, especially in the field of superplasticizers and admixtures generally. Because of that reason, this relationship is not appropriate to today's concrete mix designs and usually provides significantly lower values compared to actual strength. [48; 53; 54]

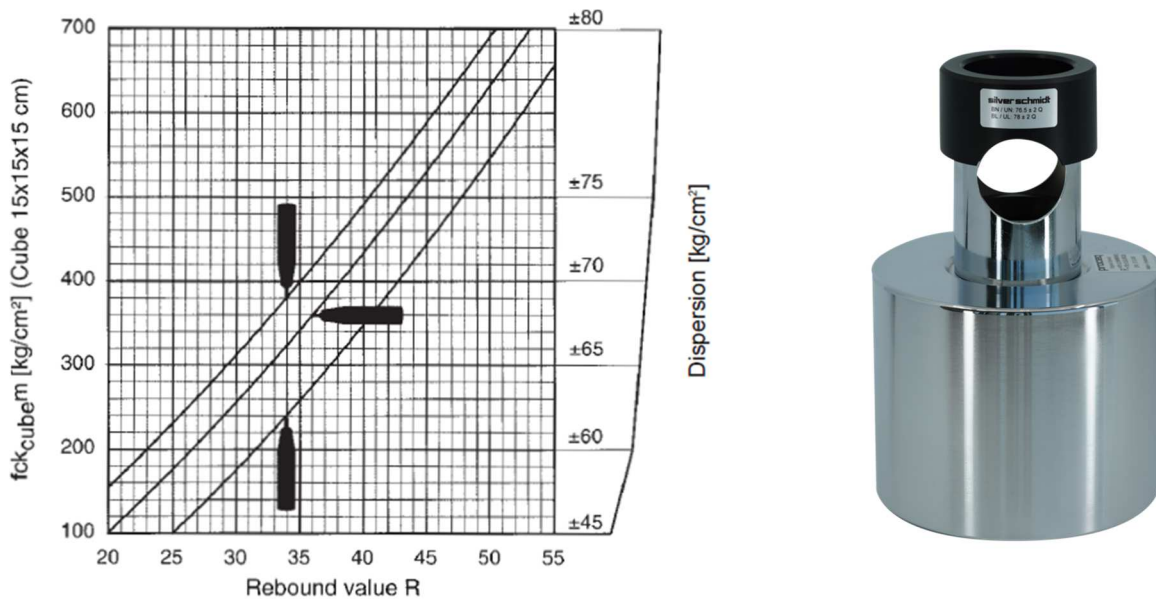

Figure 75 - Regression curve provided by manufacturer of Schmidt N [54], testing anvil [51]

Also, other one-parametric relationships exist, even for new SilverSchmidt hammers, which can provide a sufficient rough strength estimation. However, an optimal and recommended solution is an experimental determination of the strength relationship for a particular concrete mix design used in the project. This relationship can then provide pretty accurate results. [53]

The experimental determination of the regression relationship consists of the cube samples creation from the tested concrete mix design and sequential testing at different ages. Concrete cubes are tested at a defined time non-destructively by a rebound hammer and afterwards tested in the compressive strength testing machine. The concrete sample is first fixed to the compressive strength testing machine with force corresponding to 10% of the maximum estimated force before the damage. After that, rebound measurement is performed following the procedure described above. Usually, two sides of the concrete sample could be used if the testing machine allows access from both sides. When the testing with the rebound hammer is completed, the loading continues until the destructive testing is finished. Destructively determined compressive strength is recorded at the y-axis, and the result of surface hardness measurement by rebound hammer (mean value of determined rebound) is

---

recorded at the x-axis. That gives one point of future regression relationship. Standard EN 13791 recommends testing ten pairs of values (compressive strength and rebound value), which means that the measurement should consist of a minimum of ten samples at different ages. In the case of ten pairs of results after the elimination of outliers, there is still a high probability that at least eight results remain. The amount of eight results is good enough for the creation of a good regression relationship. The above-described procedures comply with the European standards EN 13791 and EN 12504-2. Hardness testing methods are also described in other standards, which recommend different measurement and evaluation procedures. An example could be ČSN EN 73 1373, which will probably not be effective soon, but now it is frequently used in the Czech Republic. [28; 48; 52; 55]