



CZECH TECHNICAL UNIVERSITY IN PRAGUE

FACULTY OF MECHANICAL ENGINEERING

Department of Process Engineering

Doctoral Thesis

**Technology and equipment for lignocellulosic  
waste conversion to biofuels and bioproducts  
with high added value**

**Doctoral study program:** Mechanical Engineering

**Study field:** Design and Process Engineering

**Supervisor/Co-supervisor:** Prof. Ing. Tomáš Jirout, Ph. D./Doc. Ing. Lukáš Krátký, Ph.D.

**ANDREY KUTSAY**

Prague, 2023

**Author:** Ing. Andrey Kutsay

**Supervisor:** Prof. Ing. Tomáš Jirout, Ph. D.

**Co-Supervisor:** Doc. Ing. Lukáš Krátký, Ph. D.

**Title Czech:** Technologie a zařízení pro zpracování odpadů v ušlechtilé formy chemických látek a energií

**Title English:** Technology and equipment for lignocellulosic waste conversion to biofuels and bioproducts with high added value

**Scope of work:** number of pages: 152

number of figures: 40

number of tables: 32

number of appendices: 28

**Academic year:** 2022/2023

**Language:** English

**University:** Czech Technical University in Prague

**Faculty:** Faculty of Mechanical Engineering

**Department:** Department of Process Engineering

# Abstract

Biogas production technology has emerged as a notable approach for decentralized waste processing in agriculture and the food industry. Conventional biogas plants typically utilize co-fermentation of lignocellulosic waste without pre-treatment, and the generated biogas is combusted in a cogeneration unit to produce electricity and heat. However, the anaerobic fermentation of untreated lignocellulosic biomass exhibits low biodegradability, and the economic viability of such technology relies heavily on green subsidies.

In the biorefinery concept, biogas production technology focuses on the intensive processing of raw materials and the targeted transformation of these materials into a portfolio of high-value products, such as methane, concentrated mineral fertilizers, cellulose fibers, acids, pigments, food supplements, and hydrogen. This approach aims to reduce dependency on green subsidies. The dissertation sought to evaluate the hypothesis that biogas plants designed in the biorefinery concept can achieve economic viability without relying on subsidized investment and product purchase costs.

Several innovative configurations of biogas biorefineries were proposed, incorporating various raw material pre-treatment techniques (mechanical disintegration, hydrothermal treatment) and product processing methods (cellulose fiber separation, biogas refining, CO<sub>2</sub> utilization for microalgae production). Original parametric models were developed for each technological configuration, enabling a comparative assessment of mass and energy balances, technical maturity, and economic viability, including sensitivity analysis.

A critical examination of the suggested variant models revealed that a biogas plant incorporating raw material crushing and biogas purification to produce pipeline-quality methane is the most technologically and economically advantageous solution. However, its attractiveness is significantly influenced by the purity and purchase prices of methane.

**Keywords:** Biogas plant, biogas upgrade, biorefinery concepts, biogas-algae, biogas-fiber.

# Abstrakt

Technologie výroby bioplynu je v současnosti jednou z typických technologií pro decentralizované zpracování odpadů ze zemědělství a z potravinářského průmyslu. Zpracování takovýchto odpadů v běžných bioplynových stanicích je obvykle založeno na kofermentaci odpadů bez důsledného předběžného zpracování. Vzniklý bioplyn je spalován v kogenerační jednotce, která produkuje elektřinu a teplo. Je všeobecně známo, že anaerobní fermentace předupravené lignocelulózové biomasy vykazuje nízkou biologickou rozložitelnost. Ekonomika provozu a investorská atraktivita jsou proto silně závislé na zelených dotacích.

Projektování technologií výroby bioplynu v konceptu biorafinerie s intenzivní předúpravou suroviny zvýší nejen její biologickou rozložitelnost, ale umožní tím i získat produkty s vyšší ekonomickou hodnotou (metan, koncentrovaná minerální hnojiva, celulósová vlákna, kyseliny, pigmenty, potravinové doplňky, vodík). Disertační práce se proto zaměřila na ověření hypotézy, zda návrh bioplynových stanic v konceptu biorafinerie může dosáhnout ekonomické atraktivity bez závislosti na dotovaných investičních nákladech a nákladech na výkup produktů.

Bylo navrženo několik originálních konfigurací technologií výroby bioplynu, které kombinují různé techniky předúprav surovin (drcení a mletí, hydrotermická předúprava) a zpracování produktů (separace celulósových vláken, čištění a zušlechtění bioplynu na biometan, využití CO<sub>2</sub> jako suroviny pro produkci mikrořas). Pro jednotlivé modelové technologické konfigurace bioplynové biorafinerie byly vytvořeny originální parametrické modely, které umožnily srovnávací hodnocení hmotnostních a energetických bilancí, technické zralosti a ekonomiky návrhů, včetně citlivostní analýzy.

Kritická technicko-ekonomická analýza navrhovaných variantních modelů prokázala, že bioplynová stanice s mechanickou dezintegrací suroviny a se zušlechtěním bioplynu na biometan je nejvíce technologicky a ekonomicky výhodným řešením. Její atraktivita je však významně ovlivněna čistotou a výkupními cenami metanu.

## **Declaration**

I confirm that the dissertation work was disposed by myself and independently, under leading of my thesis supervisor and co-supervisor. I stated all sources of the documents and literature.

In Prague .....

.....

Ing. Andrey Kutsay

## **ACKNOWLEDGMENTS**

This dissertation work is dedicated to my son, Arthur, and my wife, Oleksandra, whose unwavering love and support have been instrumental in bringing this project to fruition.

I am deeply grateful to my parents for their unwavering faith in me and their encouragement throughout my academic journey.

I would also like to express my sincere gratitude to my supervisor, Tomáš Jirout, and co-supervisor, Lukáš Krátký, for their invaluable guidance, mentorship, and support throughout the course of this research. Their insights, expertise, and generosity have been instrumental in shaping this dissertation work and bringing it to completion.

This research was supported by the Ministry of Education, Youth and Sports of the Czech Republic under OP RDE grant number CZ.02.1.01/0.0/0.0/16\_019/0000753 "Research centre for low-carbon energy technologies".

*Ing. Andrey Kutsay*

# CONTENTS

## THEORETICAL PART

<b>1. INTORODUCTION TO BIOREFINERY .....</b>	<b>8</b>
1.1 Feedstock .....	9
1.2 Sustainability and Life-Cycle Assessment.....	11
1.3 Biorefinery & Petroleum refineries.....	12
1.4 Conversion possibilities. Biorefinery definition and overall efficiencies. ....	15
1.4.1 Mechanical & Physical conversion .....	15
1.4.2 Chemical conversion.....	15
1.4.3 Thermochemical conversion .....	15
1.4.4 Biological conversion .....	16
1.4.5 Biorefinery definition and conversion efficiencies .....	16
<b>2. CRITICAL REVIEW .....</b>	<b>20</b>
2.1 Existing Biorefineries.....	20
2.2 Biogas Production as a main technology .....	27
2.2.1 Process chain of anaerobic digestion of biowaste.....	27
2.2.2 Anaerobic Fermentation .....	27
2.2.3 Biochemical process of anaerobic digestion .....	28
2.2.4 Process parameters.....	30
2.2.5 Mass-Energy Balance .....	34
2.2.6 Biogas cleaning.....	35
2.2.7 CO <sub>2</sub> removal.....	38
2.3 Biogas Biorefineries.....	40
2.3.1 Biogas related patents .....	41
<b>3. NEED FOR ACTION .....</b>	<b>43</b>
<b>4. OBJECTIVES .....</b>	<b>45</b>
4.1 General objectives .....	45
4.2 Specific objectives .....	45

## PRACTICAL PART

<b>5. MATERIALS AND METHODS .....</b>	<b>46</b>
5.1 Design of technology and process set-up parameters .....	47
5.1.1 Conventional biogas plant .....	49
5.1.2 Biogas Upgrade .....	50
5.1.3 Intensified biogas plant.....	50
5.1.4 Biogas-fiber biorefinery.....	50
5.1.5 Biogas-algae biorefinery .....	51
5.2 Parametric model .....	53
5.2.1 Block ID1: Mechanical size reduction.....	53

5.2.2	<i>Block ID2: Hydrothermal pretreatment</i>	54
5.2.3	<i>Block ID3: Anaerobic fermentation</i>	56
5.2.4	<i>Block ID4: Digestate treatment</i>	58
5.2.5	<i>Block ID5: Biogas combustion</i>	59
5.2.6	<i>Block ID6: Biogas upgrade</i>	60
5.2.7	<i>Block ID7, ID8: Algae cultivation and harvesting</i>	62
5.3	Economic evaluation technique	64
5.3.1	<i>Capital cost estimation</i>	64
5.3.2	<i>Estimating purchased equipment costs</i>	66
5.2.3	<i>Estimating Production Costs</i>	67
5.2.4	<i>Revenues, Margins and Profits</i>	68
5.2.5	<i>Discounted cash flow rate of return (Discounted payback period)</i>	69
5.2.6	<i>Economic model set-up</i>	69
<b>6</b>	<b>RESULTS</b>	<b>74</b>
6.1	Conventional Biogas Plant	74
6.2	Biogas upgrade	81
6.3	Intensified Biogas Plant	87
6.4	Biogas-Fiber Biorefinery	94
6.5	Biogas-Algae Biorefinery	101
6.5.1	<i>Biogas-algae, autotrophic growth</i>	108
6.5.2	<i>Biogas-algae, mixotrophic growth</i>	109
<b>7</b>	<b>DISCUSSION</b>	<b>111</b>
7.1	Sensitivity analysis	115
7.1.1	<i>Sensitivity on electricity selling price</i>	115
7.1.2	<i>Sensitivity on biomethane, fiber and algae selling price</i>	116
6.1	Energy return of energy invested	116
6.2	SWOT analysis	117
<b>7</b>	<b>CONCLUSION</b>	<b>119</b>
	<b>SYMBOLS</b>	<b>122</b>
	<b>LIST OF FIGURES</b>	<b>126</b>
	<b>LIST OF TABLES</b>	<b>128</b>
	<b>LIST OF REFERENCES</b>	<b>130</b>
	<b>LIST OF OWN REFERENCES</b>	<b>141</b>
	Articles in refereed journals	141
	Conference proceedings, full papers	141
	Conference proceedings, abstracts	142
	Conference contribution, poster	142
	<b>APPENDICES</b>	<b>144</b>



## 1. INTRODUCTION TO BIOREFINERY

The concept of biorefinery has gained increasing prominence in recent times. An economy that adopts a biorefinery approach minimizes material waste, replaces fossil-based products with bio-based alternatives, substantially reduces greenhouse gas (GHG) emissions, and fosters new economic opportunities through innovative policies. The rapid fluctuations in fossil oil and biomass raw material prices, coupled with high demand, necessitate the development of robust systems that offer a diverse range of products while maintaining competitiveness. An ideal economy should be founded on innovative and cost-effective biomass utilization to generate various bioproducts, such as algae, and multiple forms of bioenergy, including biogas and bioethanol. Simultaneously, it should be governed by well-established integrated biorefining policies.

Such an economy will lead to increased biomass demand, potentially resulting in higher food and commodity prices and undesirable competition for food, feed, wood products, and paper production. Reforestation, sustainability, and conservation programs must extend beyond emerging economies like Algeria and Kenya [1] to deforested regions worldwide, including countries with advanced economies. The intelligent and efficient use of biomass resources can be enhanced through biorefinery processes and their primary and secondary products, shaping a flexible and robust future economy. It is advisable to minimize the processing of food-based raw materials and instead focus on the potential of non-food resources [1].

The industrial conversion of renewable energy resources has a history spanning over 200 years. Surprisingly, sugar cane usage dates back to 6000 BC in Asia, while imports of cane sugar from overseas plantations began in the 15th century [2]. In 1811, German pharmacist G.S.C. Kirchoff observed that boiling potato starch in dilute acid transformed it into "grape sugar." In 1819, French plant chemist H. Braconnot discovered glucose formation following wood treatment with concentrated sulfuric acid. French scientist A. Payen identified cellulose in 1839 by treating wood with nitric acid and then applying a sodium hydroxide solution. In 1791, the industrialization of soap production using palm and coconut oils commenced, transforming soap from a luxury item into a consumer good [2].

Established in 1978, the International Energy Agency (IEA) Bioenergy aims to enhance cooperation and information exchange among countries engaged in biotechnology research and development. IEA Bioenergy envisions making a substantial contribution to future global energy demand by promoting environmentally sound, socially acceptable, and cost-

competitive bio-based products while reducing greenhouse gas (GHG) emissions. IEA Bioenergy Task 42 defines a biorefinery as " *Biorefinery is the sustainable processing of biomass into a spectrum of marketable products and energy* " [3].

## 1.1 Feedstock

The availability of biomass feedstock is a critical factor in designing any biorefinery concept. The location of a proposed plant significantly impacts feedstock availability, as different regions offer distinct resources. In urban areas, high concentrations of waste are expected, while rural areas often yield agricultural waste. Generally, there are three categories of biomass materials from which bioenergy can be derived: lipids, sugar/starch, and cellulose/lignocellulose [4]. Lipids are sources of fats, oils, and waxes, while sugars and starches, found in food crops, generate first-generation biofuels [4].

Lignocellulosic biomass (LCB) feedstock comprises non-carbohydrate molecules and complex carbohydrates, typically found in plant leaves and stems. As LCB has limited food value for humans, it is referred to as second-generation biofuels [4]. LCB utilization offers the advantage of producing high-value energy products, such as advanced biofuels, from relatively low-value materials [5].

The primary sources of biomass for bioenergy production are forests, agriculture, and waste, as depicted in Figure 1. Algae represents an additional, prospective bioenergy source for future utilization. Each source has its own limitations regarding availability and quality, and they often compete for biomass use, potentially affecting prices and availability [4].

From an ecological perspective, biomass holds an advantage over fossil resources, as it naturally captures CO<sub>2</sub> from the atmosphere. Consequently, biomass feedstock utilization reduces greenhouse gas (GHG) emissions, contributing to addressing global warming [6]. However, food biomass sources, such as corn, wheat straw, sugarcane, and oilseeds, which can be converted into bioethanol and biodiesel, have sparked a debate surrounding the competing uses of food and feed for biofuels and their associated social implications [5]. As a result, the processing of LCB and various waste materials appears to be a more promising option.

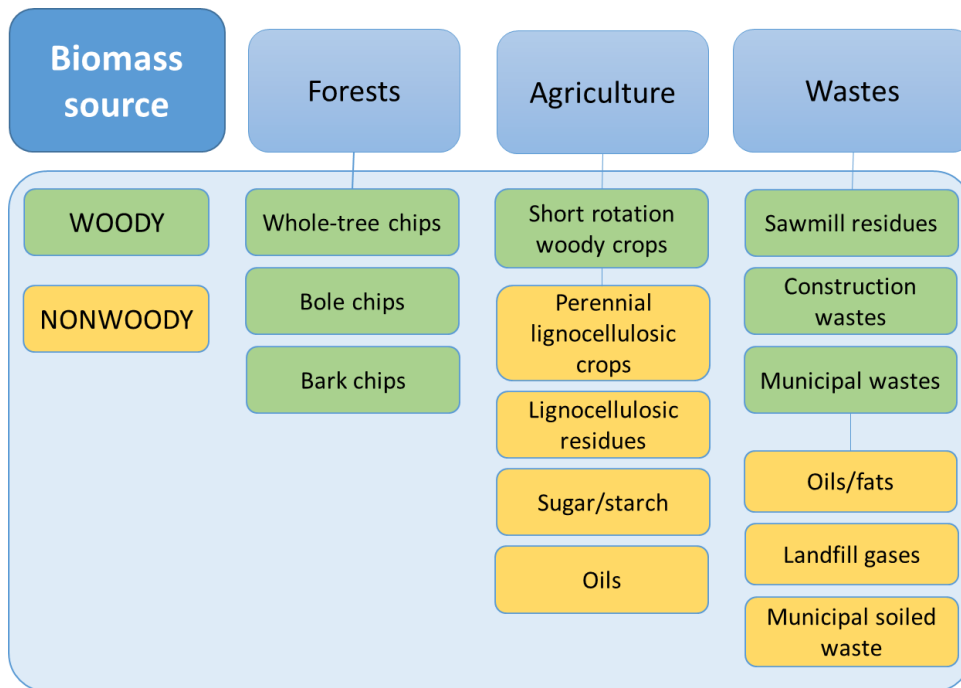

Figure 1. Source of biomass [4]

In the future, a transition from the fossil energy era to the renewable energy and biomass era is anticipated. Biomass is expected to become the sole source of renewable carbon. A timeline illustrating the shift from fossil fuel energy to biomass is depicted in Figure 2.

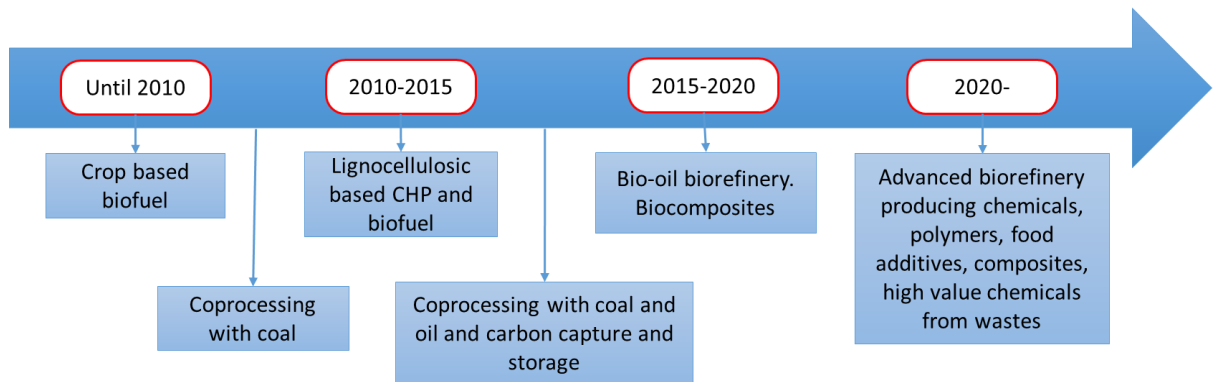

Figure 2. Estimated timeline for biorefinery deployment [6]

Today, several car manufacturers, such as Volvo, have announced plans to cease production of internal combustion engines. Countries including Germany, Iceland, the United Kingdom, Ireland, Sweden, the Netherlands, France, Spain, Slovenia, and Israel have established deadlines to prohibit the sale of new gasoline and diesel-powered vehicles [7].

## 1.2 Sustainability and Life-Cycle Assessment

Biorefinery key objective is sustainability. Any biorefinery must cover the entire value chain on their environmental, economic, and social sustainability fulfilling the whole life cycle. The concept of sustainability was introduced by the World Commission on Environment and Development (WCED, 1987). The WCED report defines sustainability as “*Development that meets the needs of the present generation without compromising the ability of future generations to meet their own needs*”. In the same manner, Theodor Roosevelt (1858-1919) said about natural resources, “*The main behaves well if it treats the natural resources as assets which it must turn over to the next generation increased and not impaired in value. Conservation means development as much as it does protection*”. It shows us that the idea of smart utilization of planet resources was introduced by our ancestors. Back to sustainability, it must be based on three factors: environmental, economic, and social [8]. From this point of view each factor may be derived. As the example, proposal in organizational strategies of three objectives must be considered [9]:

- *people* – the social consequences of its actions
- *planet* – the ecological consequences of its actions
- *profits* – the economic profitability of companies (being the source of ‘prosperity’)

It shall be noted that sustainability assessment needs to comply with different methodologies, not just one. The one generic approach of assessment has become most popular: the methodology of life cycle assessment (LCA) [8]. LCA is a systematic approach to analyze and evaluate the impacts of products or services on the environment. It covers all processes of production; it establishes flows of materials between these processes and the environment and tries to give a quantitative relation of possible damage to the environment. Sometimes, such a complicated concept could end up in a complex modelling system, where many kinds of information, submodels, as well as iterative processes should be applied. Thus, a preliminary comprehensive study is a key in creating a useful LCA research [10]. In 1997, the International Standardization Organization published the first standards of LCA, ISO 14040. It has been revised in 2006, and released in two standards, ISO 14040 and 14044, all together they are composed of methodological framework of LCA and general basis for performing LCA study [11].

According to ISO standards, Figure 3 shows different levels of LCA framework: goal and scope definition, inventory analysis, impact assessment, and interpretation.

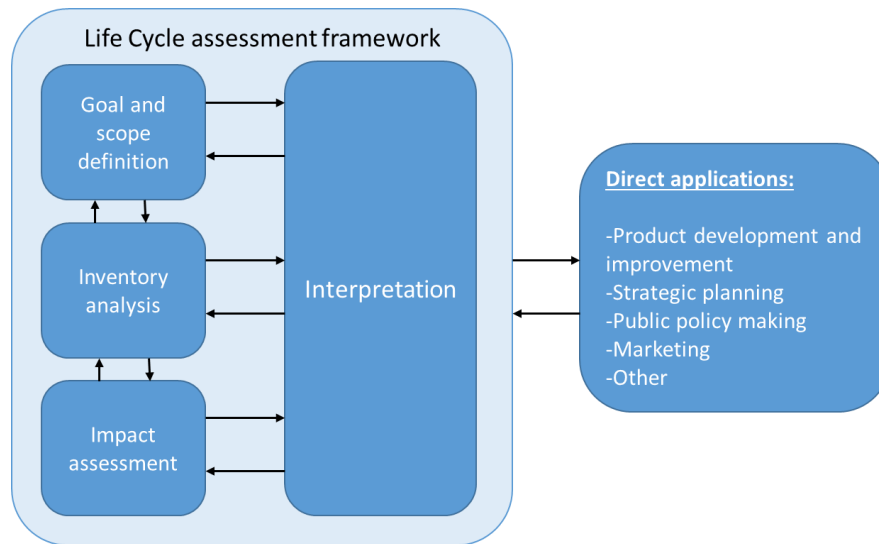

Figure 3. Stages of LCA (DIN EN ISO 14040, p. 17) [11]

In principle, these levels are studied consecutively, but while progressing of each level new information is going to appear, and this information must be reworked in an iterative process with the previously accomplished levels until desirable results would be found.

### 1.3 Biorefinery & Petroleum refineries

Speaking about previous refineries, the biorefinery directly mirrors the petroleum refineries of today, which also provide a wide range of primary chemicals from feedstocks to serve various industries, including the energy, chemical, and materials industries, see Figure 4.

Petroleum refineries are now mainly used as a source of energy, but it also composes a source for the production of primary petrochemicals (olefins, aromatics, synthesis gas) which, in 2010, estimated from 5% to 7% of total fossil fuels consumed [12]. Up to 80% wt. of all produced chemicals from petrorefineries today are used to produce polymer materials [12] [13]. In sustainable biobased economy these materials can be produced from biomass as well, where provided cost structures allow to favorably compete with fossil derived commodity products [13]. Respecting environment, comparing first generation fuels (produced from food crops) and petroleum-based fuels, the first can reduce GHG emissions by 78% of ethanol burned instead of gasoline [14].

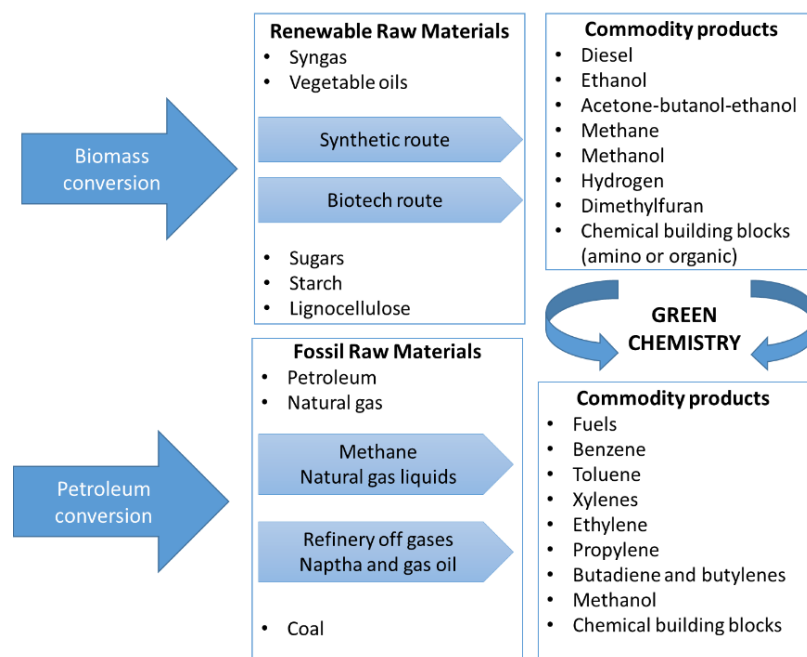

Figure 4. Petrochemical, renewable feedstocks, and their derivatives [15]

Only in Europe biobased industry turnover is 780 billion EUR, which is 4% more comparing to year 2017 [16]. So that, the potential of biobased derived products like chemicals and polymers, has already been examined in many scientific papers. In 2004, the US Department of Energy published a report which had 12 sorted chemicals which were found to be potential building blocks for our future [17]. Sustainable production of transportation biofuel is always a big challenge. Thus, coproduction of different chemicals, materials and feed can support economic feasibility.

Probably the worldwide switching from petrorefineries to biorefineries will not happen soon. It can be attractive to start by integration of biomass processing in traditional refineries. For example, the production of “green biodiesel, which include NEXBTL (Neste Renewable Diesel, despite former name BTL (biomass to liquid), the feedstock is vegetable oil and waste animal fats) process, and the catalytic cracking of pyrolytic lignin [18]. Green biodiesel is produced via hydrogenation of plant oils, or animal fat, using hydrogen available at the refinery. Neste Oil corporation, former Fortum Oil Oy, uses NEXBTL process to produce isoparaffinic fuel by hydrodeoxygenation (catalytic hydrotreatment of vegetable oils or animal fats), which is compatible with conventional diesel engines (with capacity 170-800 kT year<sup>-1</sup>) [19]. Nowadays, Neste Oil is the largest producer of Renewable diesel from wastes and residues. [20]. Neste Oil produces more than 1 million tons per a year of biodiesel, which is distributed around Porvoo, Rotterdam and Singapore [20]. Oil and syngas platforms represent several opportunities of processing biomass by applications of

petrochemical facilities, such as oil cracking, hydrotreating, pyrolysis, gasification, and chemical synthesis. Obtained products are gasoline, diesel, olefins, alcohols, acids, waxes, and many other commodity chemicals derivable from syngas [19]. Such a well-developed systematic integration processes, could use a system approach to differentiate between available feedstock (biomass and/or fossil), processing paths (biomass, petrochemical refinery), and available chemicals.

Generally, biorefineries make it possible for biomass to be an alternative to coal, crude oil, or natural gas to create C2-, C3-, or C4- based chemical platforms. Theoretically, renewable resources can mostly substitute fossil resources, in historical background such a replacement was as coal by crude oil and natural gas. Of course, we shouldn't forget that crude oil and natural gas differ significantly in composition, but as a source of energy they are the same.

Biomass comparing to fossil feedstock, firstly differ in high content of oxygen, but not considerably in carbon and hydrogen content, see Table 1.

	Crude oil [%]	Animal fats and vegetable oils [%]	Lignocellulose (wood) [%]
Carbon	85-90	76	50
Hydrogen	10-14	13	6
Oxygen	0-1.5	11	43

Table 1. CHO composition of crude oil, fats and oils, and lignocellulosic biomass [18]

Alcoholic fermentation produces ethanol, **C2-Platform**, from decomposition of cellulose. By dehydration of bioethanol to bioethylene via  $Al_2O_3/MgO$  or a zeolite catalyst, it is possible to obtain an alternative to ethylene obtained by steam cracking of petroleum fractions, natural gas, or shale gas [18].

Biobased oil can be transformed to biodiesel by transesterification, glycerol appears as a by-product. Thus, accessing us **C3-Platform**. Another C3 building block, lactic acid, can be produced through either fermentation of carbohydrates or chemical conversion starting from glycerol [6].

Using corn or sugarcane as feedstock, the **C4-Platform** is accessible, by acetone-butanol or acetone-butanol-ethanol (ABE) fermentation using *Clostridium acetobutylicum* or *Clostridium beijerinckii* under anaerobic conditions. The following process used in industry already decades and produces three solvents in a ratio ABE=3:6:1 [18].

As the wide range of biorefinery configuration is possible, a preliminary assessment of the (bio)chemical processes at the laboratory level is quite necessary. Also, it is very important to broaden sustainability assessment. So far, the variation of possibly derived materials is wide, in order to fulfil market requirements.

#### 1.4 Conversion possibilities. Biorefinery definition and overall efficiencies.

Licensors of renewable energy technologies often employ combinations of various conversion processes, resulting in innovative and appealing names that capture public attention. However, there are generally four primary conversion possibilities: mechanical conversion, thermal conversion, chemical conversion, and biological conversion [6]. Almost every known bioenergy process falls into one or more of these categories.

##### 1.4.1 Mechanical & Physical conversion

This type of conversion is performed through mechanical forces (e.g., chopping, crushing, milling), densification of feedstock (e.g., chipping, briquetting), or physical separation (e.g., mechanical fractionation, centrifugation, pressing, distillation, filtration, extraction, decantation, etc.) of products or components [21]. Crushing oil plants and oilseeds to produce oil has been practiced for a long time, dating back to the ancient Greeks who used grindstones, screws, rams, and plates for cold pressing to obtain olive oil.

##### 1.4.2 Chemical conversion

Chemical conversion processes (e.g., esterification and transesterification, hydrolysis, deoxygenation, hydrodeoxygenation and decarboxylation, steam reforming, electrochemistry, Fischer-Tropsch and methanol synthesis, etc.) alter the chemical structure of raw materials. These conversions sometimes require high temperatures and pressures and may use catalysts to increase reaction rates and productivity [6]. Chemical conversions can be reversible or irreversible and involve exothermic or endothermic reactions. Highly exothermic chemical reactions typically include recovery sections where released heat is utilized in evaporator sections.

##### 1.4.3 Thermochemical conversion

Thermochemical conversion is a specific type of chemical conversion involving thermal decomposition and thermal oxidation. Processes such as pyrolysis, gasification, and combustion treat feedstock under medium to high temperatures (350-1300°C) and/or



pressures, with or without a catalyst [6]. These conversion processes are also influenced by air access ratios.

#### 1.4.4 Biological conversion

Biological conversion processes employ enzymes, bacteria, or other microorganisms to break down biomass through anaerobic digestion, fermentation, or composting. The advantages of these conversions include the ability to produce final products in one or a few steps using mild reaction conditions (under 100°C), resulting in more sustainable production compared to other methods due to lower energy requirements and waste generation [6].

#### 1.4.5 Biorefinery definition and conversion efficiencies

The biorefinery concept is a process chain comprising systematic divisions for pre-treatment and biomass preparation, as well as separation of biomass components (primary refining) and subsequent conversion/processing steps (secondary refining) [22]. Figure 5 illustrates the biorefinery process chain.

Biomass can be converted into useful forms of energy using various processes. Factors influencing the choice of conversion process include the desired energy form, environmental standards, economic feasibility, and individual factors.

In other words, a biorefinery is characterized by an integrative, multifunctional overall concept that utilizes biomass as a diverse source of raw material for creating intermediates and product spectra, while simultaneously maximizing the raw material's energy potential. Even co-products can be utilized for food and/or feed.

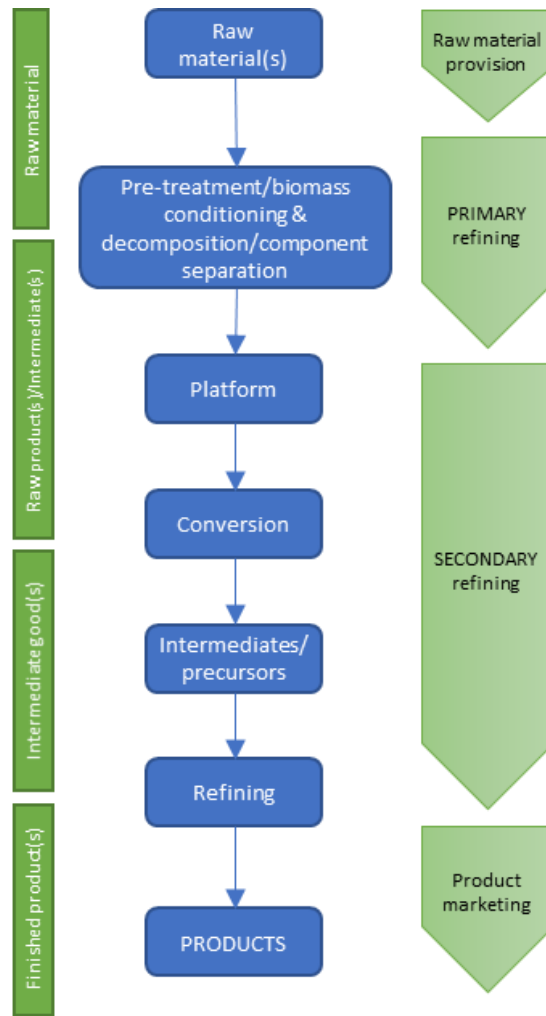

Figure 5. Scheme of biorefinery process chain [22].

Generally, biomass conversion has three main products: power/heat generation, transportation fuels, and one as a chemical feedstock [1]. Conversion techniques vary significantly, and their efficiencies also differ. For instance, thermal conversion typically has a higher yield than chemical conversion. However, this does not necessarily mean that chemical conversion is inferior in terms of life cycle assessment (LCA).

To provide a better understanding of the overall efficiencies of various conversion processes, a few examples will be discussed.

As a first example, consider a future "Thermo-Chemical" biorefinery that converts biomass into syngas and subsequently into diesel [23]. Figure 6 illustrates this biorefinery at a block level. Biomass enters the gasification chamber (thermal conversion), where it is converted into syngas. The syngas then undergoes Fischer-Tropsch (F-T) synthesis (chemical conversion), where it is synthesized and refined into diesel. Waste/tail gases are combusted

(thermal conversion) in a combined heat and power (CHP) unit to produce heat and power, which are used during the gasification stage.

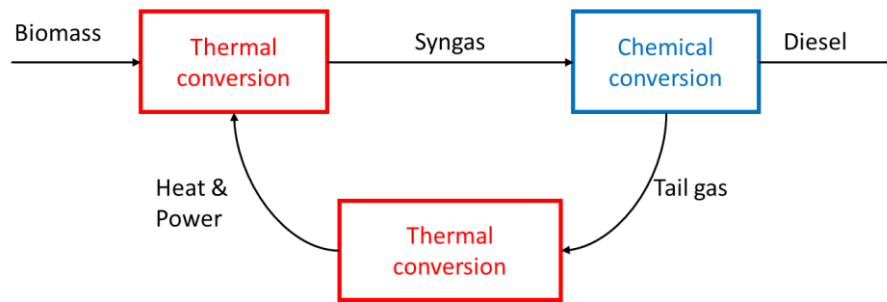

Figure 6. Biomass syngas to diesel, simple visualization [23]

The conversion efficiency of biomass to syngas is relatively high 90% [24]. Produced syngas has 50% of carbon monoxide and hydrogen [24]. The syngas can be converted into diesel via F-T to have conversion efficiency of 60% [24]. Using simple math, the overall mass conversion is around 27%. So, around quarter of initial biomass can be converted into biodiesel.

The second example is the production of ethanol with biomass, see Figure 7. The future “Bio-Chemical” biorefinery is to be examined on overall efficiency [25].

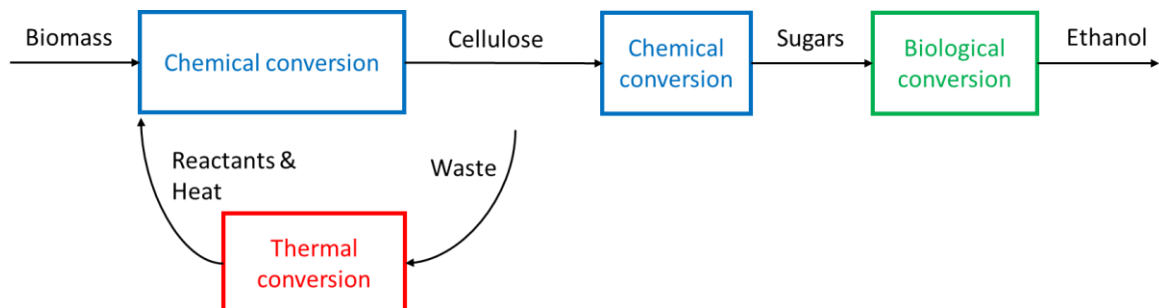
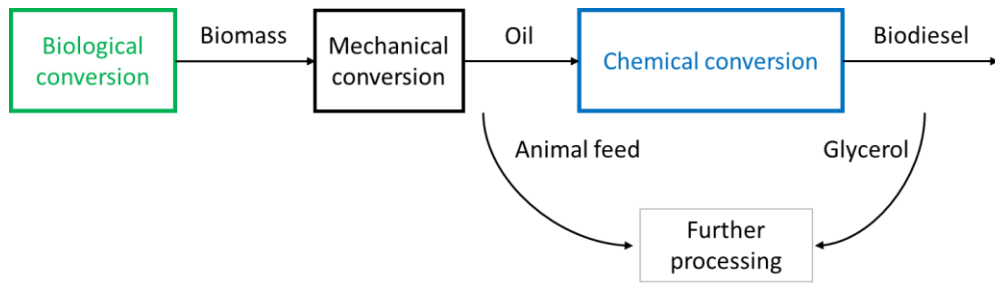

Figure 7. Cellulosic ethanol, simple visualization [25]

Pretreatment involves delignification of the biomass to make cellulose more accessible during the hydrolysis part. The average conversion of biomass to cellulose is 50% (chemical conversion); average conversion efficiency of cellulose to sugars is relatively high, 95% (chemical conversion); and average conversion of sugars to ethanol is 50% (biological conversion) [26]. The overall mass conversion efficiency is around 24%.

The third example is the production of biodiesel from vegetable oil or animal feed. This kind of “Bio-Chemical” biorefineries could be found nowadays in real life, see Figure 8 [27].



*Figure 8. Biodiesel production, simple visualization*

The concentration of fatty acids varies depending on the choice of feedstock. A reasonable estimate is a 20% conversion efficiency of biomass to oil, and subsequently, 83% of oil is converted into biodiesel [28]. Using simple calculations, the overall mass conversion is approximately 17%.

From the examples discussed, overall mass efficiencies appear relatively low. However, it is important to note that only mass distribution was taken into account. Other parameters such as yield, production cost, and lifetime, which are essential for bio-plant implementation, were not considered. The focus here was solely on understanding how mass is distributed throughout the production process. In the following chapter, an attempt is made to employ special complexity indices that describe different stages of production, ranging from feedstock to complete process design. These methodologies could aid in selecting the most sustainable production option.

## 2. CRITICAL REVIEW

### 2.1 Existing Biorefineries

There are hundreds different kinds of biorefineries in the world. Some of them produce ethanol, diesel, biogas, etc. Unfortunately, still a lot of them are either in lab or pilot scale, which were done to show the potential.

Table 2 shows some existing biorefineries, either commercial or pilot plants. As shown in the table, most commercial biorefineries are scoped to produce ethanol, biodiesel, animal feed, human food, and different types of chemicals. It looks that bioethanol and biodiesel production are the most popular between commercial biorefineries. That is quite reasonable, because half of the global mineral oil consumption is used in transport sector, nearly 20% of world energy is used today [29]. Ethanol and biodiesel have advantages, because they can be used for vehicles immediately, either in blending or alone. Also, the feedstock for ethanol and biodiesel production is simple to obtain, even it has many economic disputes. In historic overview, it is reflected as an alternative for food crops (first generation biofuels), the LCB [4]. Raising demand of bioethanol and biodiesel in the future will increase, due to upcoming politics. Up to year 2050, the biofuel demand of ethanol and biodiesel altogether raise to 24-26 EJ annually [30].

Worldwide ethanol and biodiesel production are predicted to expand at a slower rate than in the past [30]. Ethanol markets are dominated by the USA, Brazil, and, to a smaller extent, Europe. Biodiesel production dominates in Europe, and followed by the USA, Argentina, and Brazil [31].

Worldwide liquid biofuel production reached 138 billion liters in 2017, 61.5% is bioethanol, 26.1% is biodiesel and the rest is other biofuels [25]. Europe in 2017 produced 15.8 billion liters of biodiesel and 4.74 liters of bioethanol. USA in 2017 produced 13.2 billion liters of biodiesel and 74.3 billion of liters of bioethanol. In the same year, Asia produced 7.18 billion of liters of biodiesel and 5.8 billion of liters of bioethanol [32].

Owner	Feedstock	Conversion technology	Products	Scale of operation	Location
Abengoa	Stover, switch-grass, woody biomass	Biochemical	Ethanol	Commercial plant, 56 781 m <sup>3</sup> · year <sup>-1</sup>	USA, Kansas
POET	Corn cobs	Biochemical	Ethanol	Commercial plant, 94 635 m <sup>3</sup> · year <sup>-1</sup>	USA, Iowa
Flambeau River Biofuels	Mill residues, forest woody biomass, other woody biomass	Thermochemical, gasification	Biodiesel, Fischer-Tropsch waxes	Commercial plant, 34 068 m <sup>3</sup> · year <sup>-1</sup>	USA, Wisconsin
Blue fire LLC	Wood waste, sorted MSW	Biochemical	Ethanol	Commercial plant, 71 922 m <sup>3</sup> · year <sup>-1</sup>	USA, Mississippi
Mascoma	Aspen	Biochemical	Ethanol	Commercial plant, 75 708 m <sup>3</sup> · year <sup>-1</sup>	USA, Michigan
Range fuels	Woody biomass, forest residues,	Thermochemical gasification	Ethanol, methanol	Commercial plant, 75 708 m <sup>3</sup> · year <sup>-1</sup>	USA, Georgia
Renewable Energy Institute	Rice hulls and forest residues	Thermochemical gasification	Renewable diesel	Pilot plant, 2 365 m <sup>3</sup> · year <sup>-1</sup>	USA, Ohio
Ensyn	Residuals woody biomass from a hardwood flooring plant and sawmill	Thermochemical	Food flavoring, polymers, heat & electricity, synthetic biofuels	5 600 m <sup>3</sup> · year <sup>-1</sup> (advanced cellulosic biofuel, RFO)	Canada, Ontario
CropEnergies Bioethanol GmbH	Sugar beet, grain	Biochemical	Energy and material products	Commercial plant, Bioethanol 400 000 m <sup>3</sup> a year	Germany, Zeitz
Cargill	Maize	Biochemical	Various material and chemical products	Commercial plant	Germany, Krefeld
Highmark Renewable	Wheat, manure, slaughtering waste	Biological, thermochemical	Ethanol, animal feed, fertilizers, heat & electricity	Ethanol - 40 000 m <sup>3</sup> · year <sup>-1</sup>	Canada, Alberta, Vegreville
Avril Group	Rape, sunflower, oilseed	Biochemical	Biodiesel, glycerin, chemicals and polymers	Biofertilizers-10 000 t · year <sup>-1</sup> 1.5 mil. m <sup>3</sup> year <sup>-1</sup> of biodiesel;	24 sites in France (oilseed activities), 65 sites in France

						150 000 m <sup>3</sup> year <sup>-1</sup> of glycerin; 1.7 mil. m <sup>3</sup> year <sup>-1</sup> of oilseed meals	(animal nutrition, human foods)
Bioethanol plant Pischelsdorf	Maize, wheat, sugar juice, barley	Biochemical	Bioethanol, biogenic CO <sub>2</sub>	DDGS, DDGS, glycerin	Commercial plant	Austria	
Biodiesel plant Vienna	Rape seed oil, soya, feed oil, sunflower oil, waste cooking oil	Biochemical	Biodiesel, glycerin		Ethanol-240 000 t. year <sup>-1</sup> , DDGS-190 000 t. year <sup>-1</sup>	Vienna, Austria	
Biodiesel plant Arnoldstein	Waste cooking oil, animal fat	Biochemical	Biodiesel, biogas	glycerin,	Commercial plant	Arnoldstein, Austria	
ENI	CO <sub>2</sub> and discharge waters from the oil refining plant in Gela	Biochemical	Microalgae		Glycerine-15 000 t. year <sup>-1</sup>		
Royal DSM N.V.	Starch	Biochemical	Succinic acid		Commercial plant	Italy	
Petrobras	Organic materials	Biochemical	Biodiesel and ethanol		Biodiesel-50 000 t. year <sup>-1</sup>		
Vital Renewable energy company	Sugar cane	Biochemical	Ethanol		Glycerine-5 000 t. year <sup>-1</sup>	Italy	
Renfuel	Lignocellulose	Biochemical	Lignin oil		1 ha pilot production of microalgal biomass	South America	
Stora Enso	Lignocellulose	Biochemical	Kraft lignin		Yeast – 1 000 t. year <sup>-1</sup>	Brazil	
					5 biodiesel plants, 10 ethanol plants	Renfuel, Stockholm	
					3.5 mil. t. year <sup>-1</sup>	Scandinavia	

Lenzing AG	Spruce, birch, and beech wood from sustainable forests	Pulping process, Model and Lycl cell process	Main product	Viscose fibers	Commercial plant	Lenzing, Austria
Billand Vand, Kruger & Veolia	Household waste, organic industrial waste, wastewater sludge, manure, and other organic waste	Aerobic conversion, anaerobic digestion, thermal hydrolysis	Biogas and organic fertilizer.		Demonstration plant.	Grindsted, Denmark
Biowert GmbH	Grass	Mechanical separation, anaerobic digestion	Grass fiber insulation, natural fiber reinforced plastic and fertilizer made from digestate and biogas		Commercial plant, 1 340 00 Nm <sup>3</sup> biogas annually, 532 GWh <sub>e</sub> of electricity	Brensbach, Germany
Cellulac Ltd.	Lactose permeate lignocellulosic biomass	Fermentation, chemical process	Chemicals: Ethyl Lactate and polylactic acid.		Commercial plant, 100 000 metric tones	Dundalk, Ireland
Twence	Woody biomass	Fast pyrolysis	Pyrolysis-oil, power, heat		Commercial plant,	Hengelo, Netherlands

Table 2. Commercial Biorefineries [27] [3] [33] [34] [35] [36]



The location of the country is quite important for progressive and continuous development of biorefinery concept. Countries with more sunny days have better prospective, in terms of agriculture and potential source of light, algae growth for example. However, local policies are another important factor for industry drivers, that is why the level of renewable energy development could differ between countries or regions. Germany doesn't have better environmental and cultivation conditions comparing to Morocco, but Germany is more advanced in renewables technology. All biofuel-producing countries should have a special policy to support their local renewable industries. Biomass-based power production is supported in a similar way.

In Table 3 are shown feed-in tariffs for power sector in different countries.

There are different types of renewable energy support policies: feed-in tariffs, feed-in premiums, quota obligations with tradable green certificates, loan guarantees, soft loans, investment grants, tax incentives, tendering schemes [37]. However, the key mechanisms within the power sector are feed-in tariffs and feed-in premiums.

Feed-in tariffs are the guarantee of continuous retail price support over certain periods. Feed-in tariffs can bring predictability and stability, for the overall renewable energy landscape from a policy perspective and for the individual producers and investors regarding their revenue [37].

Feed-in premiums is the additional payment on top of the electricity market price, either as a fixed payment or adapted to changing market prices to limit both the price risks for plant operators and the risks of providing windfall profits at the same time [37]. Compared to feed-in tariffs the feed-in premiums have higher revenue risks.

	Year 2010 [USD. kWh <sup>-1</sup> ]						
	Czech Republic	Germany	Netherlands	Denmark	USA	Brazil	China
Solar PV	0.639	0.448	0.599	0.107	0.098	0.000	0.000
Wind	0.117	0.109	0.127	0.074	0.085	0.000	0.083
Small Hydro	0.157	0.107	0.129	0.124	0.037	0.000	0.033
Biomass	0.189	0.128	0.199	0.186	0.079	0.000	0.111
Waste	0.000	0.000	0.082	0.132	0.078	0.000	0.000
Geothermal	0.236	0.174	0.000	0.000	0.068	0.000	0.000
Marine	0.000	0.000	0.000	0.124	0.068	0.000	0.000
	Year 2015 [USD. kWh <sup>-1</sup> ]						
	Czech Republic	Germany	Netherlands	Denmark	USA	Brazil	China
Solar PV	0.000	0.097	0.120	0.089	0.003	0.000	0.145
Wind	0.000	0.98	0.153	0.062	0.004	0.000	0.086
Small Hydro	0.000	0.091	0.122	0.104	0.002	0.000	0.036
Biomass	0.000	0.065	0.060	0.000	0.002	0.000	0.120
Waste	0.000	0.000	0.078	0.086	0.002	0.000	0.000
Geothermal	0.000	0.279	0.070	0.000	0.002	0.000	0.000
Marine	0.000	0.000	0.122	0.104	0.002	0.000	0.000
	Year 2019 [USD. kWh <sup>-1</sup> ]						
	Czech Republic	Germany	Netherlands	Denmark	USA	Brazil	China
Solar PV	0.000	0.000	0.110	0.000	-	0.000	0.000
Wind	0.000	0.108	0.078	0.000	-	0.000	0.000
Small Hydro	0.000	0.089	0.123	0.000	-	0.000	0.033
Biomass	0.000	0.106	0.096	0.000	-	0.000	0.109
Waste	0.000	0.115	0.077	0.086	-	0.000	0.000
Geothermal	0.000	0.282	0.055	0.000	-	0.000	0.000
Marine	0.000	0.000	0.123	0.000	-	0.000	0.000

Table 3. Renewable Energy Feed-in Tariffs [38]

While Europe is trying to support and increase share of bio-based materials in chemicals sector, there are no related supporting policies, which have been applied in the chemical

industry [39]. On the Figure 9 are the main drivers of regional or national differences in the industrial commercialization.

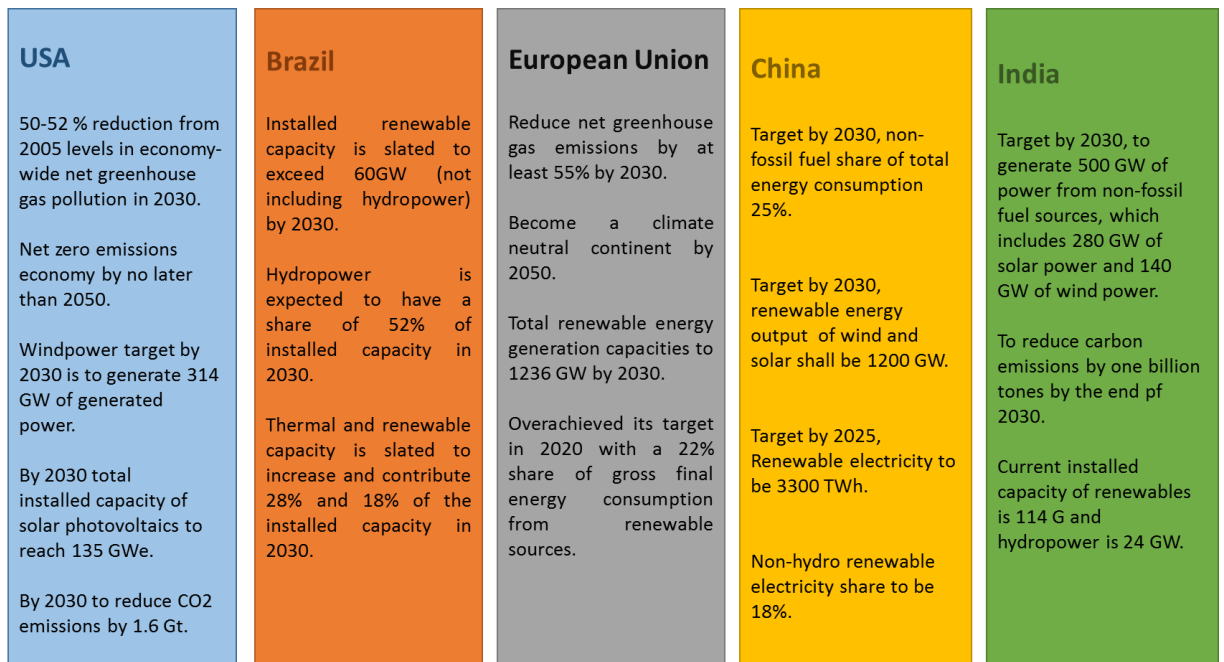

Figure 9. Worldwide Mandates and Subsidies. Current policy status in five major world regions [40] [41] [42] [43] [44]

The potential of revenue from bio-based materials is one of the constituents of sustainability. The biomass value chain is offering an attractive revenue throughout the whole process, starting from the input of agricultural biomasses and up to biofuels selling. Figure 10 shows the revenues from each certain sector. Each individual sector is opening new perspectives for farmers, processing companies, logistics etc.

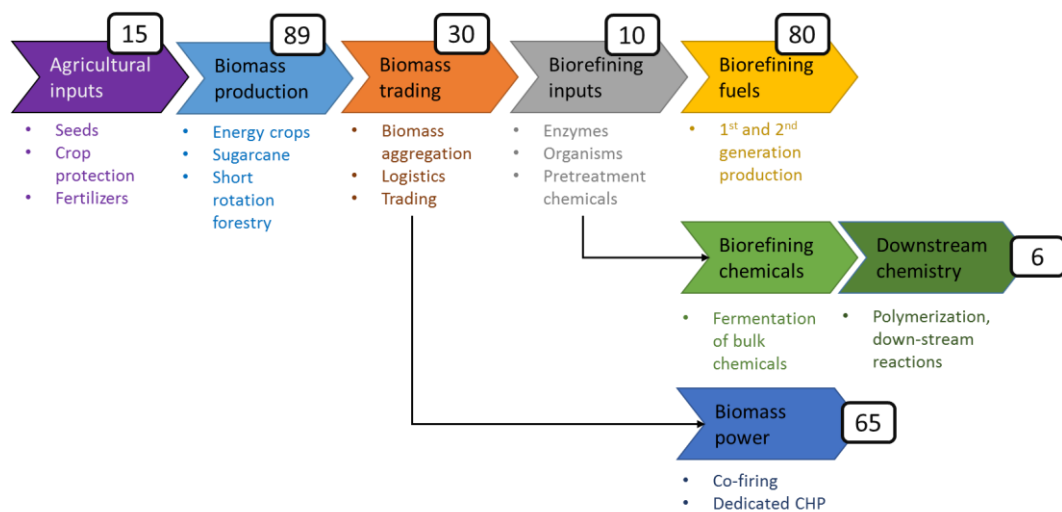

Figure 10. Revenue Potential. There are significant revenue potentials along entire biomass value chain. The values given are approximate business potential in US\$ billions by 2020 [39]

## 2.2 Biogas Production as a main technology

All assessed biorefinery plants will incorporate biogas production as a fundamental process. Biogas is a highly versatile product. By purifying biogas, biomethane can be obtained. This biomethane can be injected into the grid, used as compressed natural gas (CNG), or combusted directly in a combined heat and power (CHP) unit to generate heat and electricity.

Biogas production was selected primarily due to its diverse conversion possibilities.

### 2.2.1 Process chain of anaerobic digestion of biowaste

The following figure is based on a systematic supply chain perspective [45],

- **Substrate chain:** Waste generation, collection, transportation and supply to the digestion facility and necessary pretreatment of waste before feeding the digester.
- **Transformation process:** Biological and chemical transformation processes of feedstock in the digester which leads to valuable products.
- **Product chain:** Post-treatment of outflows from the digester that refines these into improved value products, and their distribution and utilization.

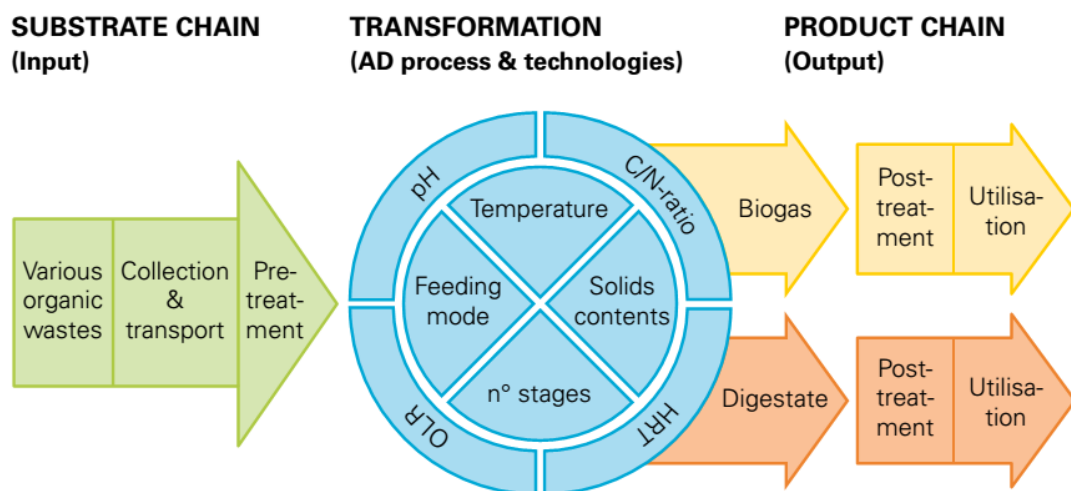

Figure 11. Process chain of anaerobic digestion [45]

### 2.2.2 Anaerobic Fermentation

Anaerobic digestion (AD) is a microbiological process in which organic matter is decomposed in the absence of oxygen. This process occurs naturally in various environments, such as swamps or the stomachs of ruminants. By employing engineering techniques and controlled design, AD can be applied to process biodegradable organic matter in air-tight reactor tanks, commonly referred to as digesters or fermenters, to produce

biogas. Various groups of microorganisms are involved in the anaerobic degradation process, which generates two main products: energy-rich biogas and a nutrient-rich digestate.

Anaerobic digestion of organic waste offers numerous benefits, including the generation of renewable energy, a reduction in greenhouse gas emissions, decreased fossil fuel consumption, job creation, and the completion of nutrient cycles. It converts organic waste material into valuable resources while simultaneously reducing solid waste volumes and waste disposal costs. Biogas as a renewable energy source not only improves a country's energy balance but also contributes to the preservation of natural resources by reducing deforestation and environmental pollution from waste and fossil fuel usage [46].

The calorific value of biogas is approximately 6.0-6.5 kWh Nm<sup>-3</sup>, depending on methane concentration, which typically ranges from 55-70% vol. [46]. The net calorific value depends on the efficiency of the biogas burners or other devices used to process the biogas.

### 2.2.3 Biochemical process of anaerobic digestion

Anaerobic decomposition of organic matter occurs in a four – step process.

- **Hydrolysis**

In this step, bacteria transform complex organic materials into liquefied monomers and polymers. For example, proteins, carbohydrates, and lipids are converted into amino acids, monosaccharides, and fatty acids, respectively [46]. This extracellular enzyme-mediated transformation of high-mass organic molecules into basic structural building blocks is essential, as particulate organic materials are too large to be directly absorbed and used by microorganisms as a substrate. Carbohydrate hydrolysis takes place within a few hours, while protein and lipid hydrolysis occur within a few days. Lignocellulose and lignin are degraded slowly and incompletely [46].

- **Acidogenesis**

In this phase, the monomers formed during hydrolysis are taken up by different facultative and obligatorily anaerobic bacteria and degraded into short-chain organic acids, C1-C5 molecules, alcohols, nitrogen oxide, hydrogen sulfide, hydrogen, and carbon dioxide. The concentration of the intermediately formed hydrogen ions affects the type of fermentation

products. Higher partial pressure of hydrogen results in fewer reduced compounds, such as acetate. The degradation of amino acids also leads to ammonia production [46].

- **Acetogenesis**

During this step, long-chain fatty acids, volatile fatty acids, and alcohols are transformed by acetogenic bacteria into hydrogen, carbon dioxide, and acetic acid. This reaction reduces both the biological oxygen demand (BOD) and chemical oxygen demand (COD) and decreases the pH [46]. Hydrogen plays an essential intermediary role in this process, as the reaction will only occur if the partial pressure is low enough to thermodynamically allow the conversion of all acids. Hydrogen scavenging bacteria lead to a lower partial pressure. Thus, the hydrogen concentration in a digester is an indicator of its "health" [5].

- **Methanogenesis**

In the final stage, methanogenic bacteria convert hydrogen and acetic acid into methane gas and carbon dioxide. Methanogenesis is affected by conditions in the reactor, such as temperature, feed composition, and organic loading rate [46].

The gaseous product, biogas, consists mainly of methane, 60% vol. in average, and carbon dioxide, 35% vol. in average. Also, biogas contains several other gaseous “contaminants” such as hydrogen sulphide (easily detected by its smell of rotten eggs), nitrogen, oxygen and hydrogen. Biogas with methane content higher than 45 % is flammable; the higher the CH<sub>4</sub> content the higher the energy value of the gas [46]. Table 4 shows the composition of biogas.

Components	Symbol	Farm-scale AD plant	Sewage treatment plant	Natural gas
		vol. %, or indicated		
<b>Methane</b>	CH <sub>4</sub>	55 – 60	60-65	81-89
<b>Other hydrocarbons</b>	-	-	-	3.5-9.4
<b>Carbon dioxide</b>	CO <sub>2</sub>	35-40	35-40	0.67-1.00
<b>Water</b>	H <sub>2</sub> O	<i>Depends on fermentation operation temperature</i>		-
<b>Hydrogen sulphide</b>	H <sub>2</sub> S	25-30 ppm	<0.5-6800 ppm	0-2.9 ppm
<b>Nitrogen</b>	N <sub>2</sub>	<1-2	<1-2	0.28-14.00

<b>Oxygen</b>	O <sub>2</sub>	<1	<0.05-0.70	0
<b>Hydrogen</b>	H <sub>2</sub>	0	0	-
<b>Ammonia</b>	NH <sub>3</sub>	~100 ppm	<1-7 ppm	0
<b>Siloxanes</b>	-	<0.03-<0.2 mg. m <sup>-3</sup>	<1-400 mg. m <sup>-3</sup>	-
<b>Lower heating value</b>	-	19.7-21.5 MJ. Nm <sup>-3</sup>	21.5-23.3 MJ. Nm <sup>-3</sup>	31-40 MJ. Nm <sup>-3</sup>

Table 4. Typical composition of biogas from biowaste [47] [27].

In the Table 5 is shown principle of anaerobic biodegradation of organic substances [48].

	Substrate	Product	Organisms
<b>HYDROLYSIS</b>	polysaccharides	sugars	hydrolytic fermentation
	proteins	Amino acids	
	fats (lipids)	higher fatty acids	
		glycerol	
<b>ACIDOGENESIS (fermentation)</b>	Sugars	low fatty acid	acidogenic desulphation
	amino acids	alcohols	
	higher fatty acids	acetic acid	
	glycerol	CO <sub>2</sub>	
		H <sub>2</sub>	
<b>ACETOGENESIS</b>	butyric acid	acetic acid	syntrophic acetogens
	propionic acid	CO <sub>2</sub>	
	ethanol	H <sub>2</sub>	
<b>METHANOGENESIS</b>	acetic acid	CH <sub>4</sub>	methanogens
	CO <sub>2</sub>	CO <sub>2</sub>	acetotrophic
	H <sub>2</sub>		hydrogenotrophic

Table 5. Principle of AD fermentation [48]

#### 2.2.4 Process parameters

Maintaining a healthy growth rate of microorganisms is crucial for successful anaerobic digestion. A temperature change during fermentation of  $\pm 10^{\circ}\text{C}$  can lead to the formation of new bacteria, which can create less favorable conditions for growth. After an occasional change in process parameters, it could take up to three weeks for the production to recover.

The conditions required for fermentative bacteria during the first and second stages (hydrolysis and acidification) differ from the requirements for the other stages. The best environmental conditions for all microorganisms involved in degradation can only be achieved in two-phase fermentation. The first phase is for hydrolysis and acidogenesis, while the second phase is for acetogenesis and methanogenesis. This means that each phase is carried out separately in two fermenters. For degradation processes occurring in a single phase altogether, the environmental requirements for methanogenesis must be prioritized because these bacteria have a lower growth rate and higher sensitivity to environmental factors [46].

However, for lignocellulosic biomass (LCB), the situation is different. The hydrolysis stage is the limiting factor in the process, and therefore it needs higher priority [46]. By optimizing the conditions for each stage of anaerobic digestion, the efficiency and overall performance of the process can be improved.

#### *2.2.4.1 Temperature*

Anaerobic digestion is principally feasible under almost all climatic conditions. Nevertheless, at low ambient temperature ( $<15^{\circ}\text{C}$ ) the digestion process does not work easily [47]. In cool climatic conditions, either a heating system must be installed, or a larger digester must be built to increase retention time [45]. Heating systems and good insulation can provide necessary operating temperature even during cold climates, however the required additional invests for utilities makes it economically less favorable. During biogas plant territorial selection stage temperatures like, maximum and minimum average annual dry bulb temperature (summer and winter), average annual dry and wet bulb temperatures, are very important, because suitable climatic conditions can save project budget and operational costs. Digesters built underground provide minimization of temperature changes by buffer capacity of the soil. For household digesters the design should ensure gas production even during unfavorable season of the year. Given the additional investments required for colder climates, a general rule of thumb is that the cost of biogas production increases as the temperature decreases.

Mainly, there are two ideal temperature ranges for the operation with anaerobic bacteria. Mesophilic microorganisms have range  $32^{\circ}\text{C}$  to  $42^{\circ}\text{C}$ , and thermophilic microorganisms have range  $48^{\circ}\text{C}$  to  $55^{\circ}\text{C}$  [46]. Psychrophilic microorganisms can also be used when the fermenter doesn't have preheating system, since they can survive at a temperature range



from 0°C to 20°C [48]. Operation of a digester in mesophilic range is more stable, as these microbial communities can tolerate greater changes in environmental parameters and consume less energy. Interruption by ammonium is less critical in the mesophilic range as compared to thermophilic conditions, because of lower content of free ammonia [46]. On the other hand, the mesophilic microorganisms are slower and thus a longer fermentation time in digester is needed to reach the optimum yield of biogas production [45]. Thermophilic microorganisms are faster and can even show a higher yield. Also, suspension has lower viscosity, which makes mixing and pumping easier, and less energy demand. Main operational disadvantage of thermophilic organisms is that they create more NH<sub>3</sub>, H<sub>2</sub>S and H<sub>2</sub>, which create less favorable conditions for operation and possibility of floatation of lipid substrates [48].

#### *2.2.4.2 Specific surface area of material*

To assist the biochemical reaction, the surface area of material should be kept as large as possible. To increase the surface area of material, milling or comminution of the substrate is preferred in many cases before processing [47]. For an efficient processing it is suggested to have feedstock not bigger than 15mm [49].

#### *2.2.4.3 pH value*

The situation regarding pH value is similar to that for temperature. Those microorganisms, which are involved in the different stages of biodegradation, require different pH values. The optimum pH for hydrolysis and acid-forming bacteria is in a range from 5.2 to 6.3. These bacteria can live in slightly higher pH values. The only problem is that their activity is slightly reduced. In contrast, the pH value in the neutral range from 6.5 to 8 is essential for acetogenesis and methanogenesis. Thus, if the fermentation process occurs in a single digester, this pH range must be maintained [50].

Regardless of whether process is single-stage or multi-stage, the pH value is established automatically in the system with help of alkaline and acid metabolic products formed during anaerobic digestion [50].

If too much organic matter is introduced into the process within too short period of time, or if methanogenesis is inhibited for some other reason, the acid metabolic products of acidogenesis will accumulate. Normally the pH value is established in the neutral range (6.5-8) by the carbonate and ammonia buffer. If the system's buffer capacity is exhausted, for

example, if too many organic acids have built up, the pH value decreases. This, in the same way, increases the inhibitory effect of hydrogen sulphide and propionic acid. Due to great importance of pH value inside the digester, it should be every time measured [50].

#### *2.2.4.4 Carbon to nitrogen ratio*

The difference between carbon and nitrogen amount in organic materials is represented by C:N ratio. The C:N ratio is an important parameter in estimating nutrient deficiency and ammonia inhibition [45]. Optimal C:N ratio in anaerobic digesters is between 16:1 and 25:1 [46]. High C:N ratio is the result of rapid consumption of nitrogen by methanogens, which then results in reduced gas production. On the other side, a low C:N ratio causes ammonia accumulation and pH value can grow more than 8.5. Such conditions can be toxic to methanogenic bacteria. Although methanogenic bacteria can adapt to high ammonia concentration this only occurs if concentrations are increased gradually allowing time for adaptation. Proper C:N ratios can be ensured by mixing various feedstock materials, with high (organic solid wastes) and low (sewage or animal manure) C:N ratios to obtain a perfect ratio level [50].

#### *2.2.4.5 Organic loading rate and fermentation time of the digester*

Whenever a biogas plant is being designed and constructed, high attention is paid to economic considerations. Consequently, when the size of digester is being chosen the focus is not necessarily the highest biogas yield or the full decomposition of the organic matter contained in the substrate [50]. If the aim was to reach maximum decomposition of the organic material, sometimes quite long fermentation time would be necessary for the substrate in digester, together with large digester volumes, because some substances take very long time to break down [50]. Thus, to find balance between degradation performance and acceptable capital cost is critically important.

At this point, the organic loading rate (OLR) is a crucial operating parameter. It shows how many kilograms of volatile solids (VS, or organic dry matter – ODM) can be fed into digester per every cubic meter of working volume per unit of time. The organic loading rate is expressed in the units  $\text{kg}_{\text{vs}} \text{m}^{-3} \text{d}^{-1}$  [50]. Overloading leads to a significant rise in volatile fatty acids, which can result in acidification and system failure. In industrialized countries the OLR is in the range  $4\text{-}8 \text{ kg}_{\text{vs}} \text{m}^{-3} \text{d}^{-1}$ , which results in VS removal in the range of 50-70 % [51]. This is ideal for continuous stirred tank reactors (CSTR). However, for non-stirred

AD systems which are dominant in developing countries, an OLR below  $2 \text{ kg}_{\text{vs}} \text{ m}^{-3} \text{ d}^{-1}$  is preferred and considered to be suitable.

In this thesis it is assumed that OLR in the range  $1\text{-}2 \text{ kg}_{\text{vs}} \text{ m}^{-3} \text{ d}^{-1}$ , because in reality the mixing within the digester occurs only once in 5-10 minutes [46]. The result of not continuous mixing will lead to the smaller OLR, as the substrate will spread less uniformly, for every cubic meter, inside the digester.

### 2.2.5 Mass-Energy Balance

General stoichiometry equation for methane creation is as follows [48],

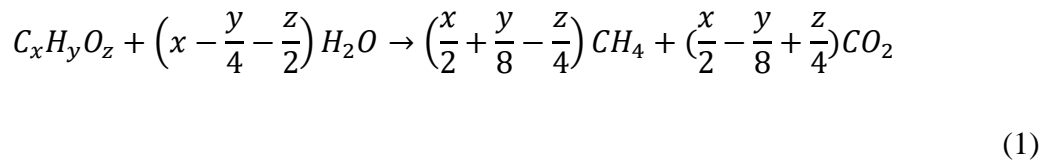

Where  $x$ ,  $y$  and  $z$  are the number of atoms of each element.

The amount of created methane is depended on free electrons which have molecules of the given organic matter. It is said that, for full oxidation of methane which was created from Eq. (1) it is necessary same amount of oxygen to oxidize the original matter [48].

COD (Chemical Oxygen Demand) represents the maximum chemical energy which is presented in the feedstock. Since microbes convert chemical energy to methane, this is also the maximum energy that can be recovered as biogas, though losses for the energy demand of the microbes themselves have to be subtracted, as well as for material that is not degradable by anaerobic microorganisms (like lignocellulosic feedstock) [47].

Theoretical yield of methane from the given substrate can be calculated from Eq. (2) for mass based, and Eq. (3) for volume based [48].

$$Y_{CH_4m} = 0.25 * COD \left[ \frac{g}{g} \right] (CH_4, substrate) \quad (2)$$

$$Y_{CH_4g} = 0.35 * COD \left[ \frac{l (0^\circ C, 1 atm)}{g} \right] (CH_4, substrate) \quad (3)$$

COD analysis for the given substrate can be done in the laboratory. After theoretical methane yield calculation, normally small vessels up to 20L are used for determination of real yield with respect to time.

For correction of theoretical yield of methane estimation, it is also taken nitrates, nitrites (N) and sulphates (S) into account. It is necessary from the COD of substrate to subtract COD necessary for reduction  $NO_2^-$  and  $NO_3^-$  to  $N_2$ , and  $SO_4^{2-}$  to  $S^{2-}$  [47].

$$Y_{CH_4g} = 0.35 * (COD - N - S) \left[ \frac{l (0^\circ C, 1 atm)}{g} \right] (CH_4, substrate) \quad (4)$$

In Figure 12 is shown mass balance of selected nutrients in a small agricultural digester, having corn silage and manure as a feedstock. From that follows that carbon and hydrogen are mostly converted into biogas, whereas nitrogen and sulfur are mainly converted into digestate.

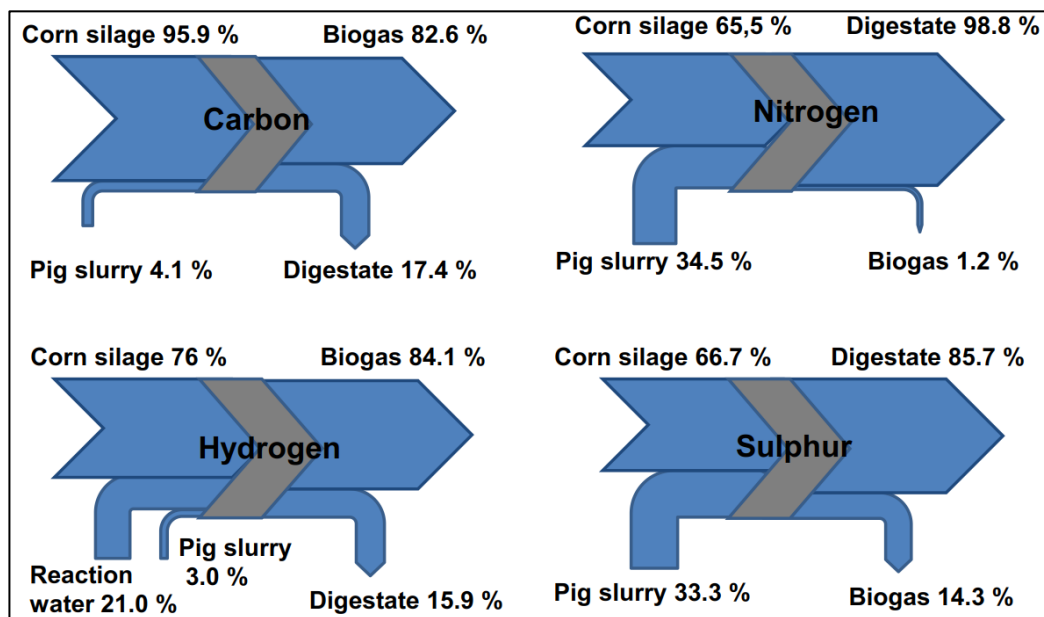

Figure 12. Mass balance of selected elements [1].

### 2.2.6 Biogas cleaning

Biogas mainly consists of methane and carbon dioxide, as can be seen in Table 4. Since biogas is produced from suspension which mainly consists of water, some water is evaporated during fermentation. In the Table 6 is shown the influence of temperature on water vapor concentration in biogas.

Temperature [°C]	Saturated water vapor pressure [kPa]	Content of water vapors [%vol.]	Water content at 100% saturation [mg.m <sup>-3</sup> ]
0	0.6100	0.602	4 846
+15	1.7048	1.683	12 820
+35	5.6226	5.549	39 600
+55	15.7366	15.532	104 300

Table 6. Biogas water vapor concentration with respect to temperature [52].

### 2.2.6.1 Water removal

Water from biogas can be removed by increasing pressure, lowering temperature or by absorption or adsorption. Other impurities that can dissolve in water, like siloxanes, will be removed together with the water and this shall be considered when designing systems for disposal of water.

Cooling of biogas can be simply achieved by burying the pipeline into the ground and providing the bottom pipe with condensate drains or gas traps [47]. Also, biogas can be cooled in heat exchanger by cooling water to condensate the water vapor, see Figure 13 [52].



Figure 13. Heat exchangers for water vapor reduction [52].

Water removal by adsorption is usually done by silica, aluminum oxide, magnesium oxide, activated carbon or zeolites. Pressure swing adsorption is a great example of such an application.

Absorption can be achieved in glycol solutions (e.g., ethylene glycol, diethylene glycol, triethylene glycol) or by using hygroscopic salts. The salt is dissolved when it absorbs water, and the salt is usually not regenerated [47].

#### *2.2.6.2 Hydrogen sulphide removal*

Hydrogen sulphide (sulfane) can be removed in the fermenter during biodegradation or after fermenting. It is one of the most problematic compounds in biogas which concentration shall be regulated.

Sulfane bothers the combustion of biogas by forming sulfur dioxide, which has allowable emission limit. Also, sulfane can react with condensed water to form ionic hydrogen and/or sulfuric acid, which is a highly corrosive chemical compound. When biogas is used for combustion in cogeneration unit, most internal combustion engine manufacturers require to limit sulfane up to 100 ppm [53].

One of the cheapest removals of sulfane is by injecting air/oxygen (microaeration) into the fermenter, hydrogen sulphide will react with oxygen and form elementary sulfur through biological oxidation. Some sulphate dioxides can also be formed. The oxidation is catalyzed by *Thiobacillus* bacteria that are normally present in the fermenter [47]. A disadvantage of this technology is that if too much oxygen is injected it will affect the digestion process negatively. Another attention shall be paid to methane and oxygen concentration to not form explosive mixture. For upgrading technology, it can be also a problem, because it is hard to separate nitrogen from methane [47]. It is possible to install a biological filter with bacteria out of fermenter that can oxidize hydrogen sulphide.

Another method for hydrogen sulphide removal from produced biogas, is by introducing iron ions in the form of  $\text{FeCl}_2$ ,  $\text{FeCl}_3$  or  $\text{FeSO}_4$ . By this insoluble iron sulphide ( $\text{FeS}$ ) is produced and it would precipitate in the digester [47]. Such a treatment is usually done in sewage sludge plants for simultaneous removal of phosphate.

### 2.2.6.3 Siloxanes

The structure of siloxanes consists of dimethylsiloxane unit [48]. During combustion of biogas in engine,  $\text{SiO}_2$  is created on the walls of chamber, piston, or spark plugs. Created  $\text{SiO}_2$  blocks the ways of flue gas removal and destroys the engines of cogeneration units, see Figure 14 [52].



Figure 14. Siloxane influence on engines [52].

Every manufacturer of internal combustion engines states different limits of siloxanes. However, for most manufacturers of internal combustion engine it is required to have less than 2.5 ppm of siloxane [54].

Normally, created siloxane in biogas can be treated by silica gel or activated carbon.

### 2.2.7 CO<sub>2</sub> removal

Upgraded biogas, biomethane, has the same properties as natural gas, especially in terms of calorific value. Thus, the cleaned or upgraded biogas can be directly injected into natural gas grid [55]. In Figure 15 are shown biogas upgrading methods via CO<sub>2</sub> removal.

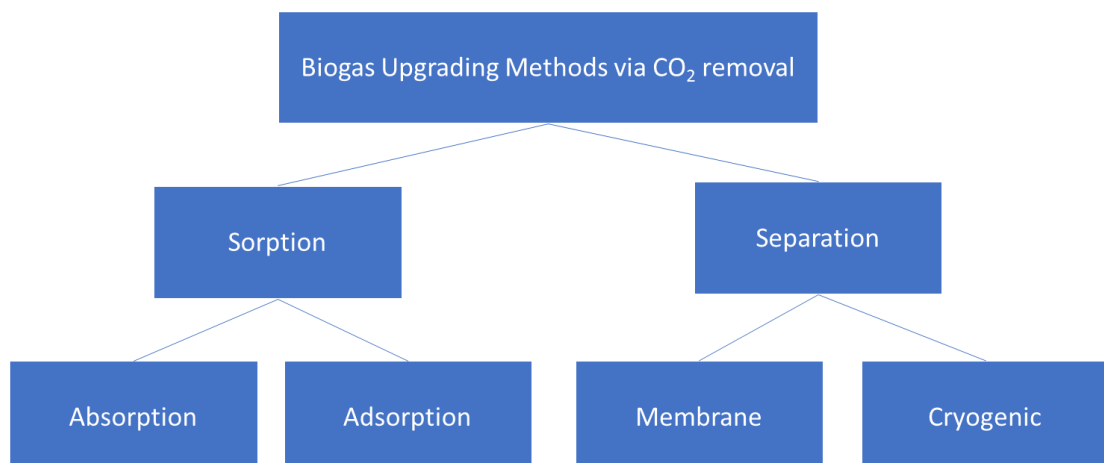

Figure 15. Biogas upgrading technologies via CO<sub>2</sub> removal [56].

Water scrubbing is a physical adsorption method, which is based on the higher solubility of H<sub>2</sub>S and CO<sub>2</sub> in water as compared to CH<sub>4</sub>. Water scrubbing is operated at pressure range 6-10 bars [57]. Raw biogas is flowing counter-current flow with liquid in a column, as the result liquid adsorbs CO<sub>2</sub> leaving with high content of CH<sub>4</sub> [56]. This process can achieve more than 99% of CH<sub>4</sub> purity [56]. The advantages of this process are process simplicity, high methane purity, less methane loss and low operation cost. The disadvantages are, it requires huge amount of water, high energy consumption, external heating, and chance of biological contamination [56].

Chemical adsorption method is used together with organic solvents, like polyethylene glycol ether, methanol, and N-methyl pyrrolidone [57], which are the most famous chemical to adsorb CO<sub>2</sub> and H<sub>2</sub>S from raw biogas. This process can achieve 96-98% of CH<sub>4</sub> purity [56]. The advantages of this process are, more CO<sub>2</sub> dissolved per unit volume, high methane purity, low methane loss and faster process than physical scrubbing. The disadvantages are, high energy demand, require pretreatment, safety difficulties in handling with solvent and salt precipitation, foaming and poisoning of amine [56].

Pressure swing adsorption (PSA) process is method which uses special adsorbents, like Zeolite 5A, Zeolitic Imidazolate Frameworks and Metal-Organic Frameworks, to separate biogas from H<sub>2</sub>S, CO<sub>2</sub>, H<sub>2</sub>O, O<sub>2</sub> and N<sub>2</sub> [57]. This process usually occurs at 4-10 bars [57]. With PSA it is possible to achieve 96-98% of CH<sub>4</sub> purity [56]. The advantages of this process are, high gas quality, low methane losses, dry process, low energy demand and no chemical demands. The disadvantages are, complexity, requires pretreatment [56].

Membrane separation method is based on the particle size and chemical affinity of different molecules [57]. There are two types of membranes, which are used for separation, organic polymers (polyimide, cellulose acetate) and non-polymer (zeolite, activated carbon, silica, metal-organic framework) [56]. Membrane separation process can achieve 92-96% of CH<sub>4</sub> purity [57]. The advantages of this process are environmentally friendly, low energy consumption, low operation cost and process simplicity. The disadvantages are, low membrane selectivity, pretreatment is necessary, high capital cost and low CH<sub>4</sub> purity [56].

Cryogenic Separation method is based on condensability of different gassed at different temperature and pressure ranges [56]. This process is carried out at pressure 80 bars and -170°C in four stages [57]. The cryogenic separation method is useful in producing liquid natural gas (LNG) and liquid methane. This process can achieve 97-98% of CH<sub>4</sub> purity [56].



The advantages of this process are high gas quality, low methane losses, and environmentally friendly. The disadvantages are, very high investment and operational costs, require pretreatment [56].

### 2.3 Biogas Biorefineries

The utilization of biogas in biorefineries is a favorable option due to its low technology cost and simplicity. Existing biogas facilities can be expanded to include additional products and transformed into biogas biorefineries. Future biorefineries are expected to consist of various concepts integrated together. The design of new biorefineries should adopt a top-down approach that prioritizes the full utilization of the feedstock.

Figure 16 depicts a general view of biogas biorefinery. It consists of following technological steps:

- Handling of substrate, together with pre-treatment and feeding equipment,
- Digestion or anaerobic fermentation of the substrate and biogas collection systems,
- Digestate storage and posttreatment units.

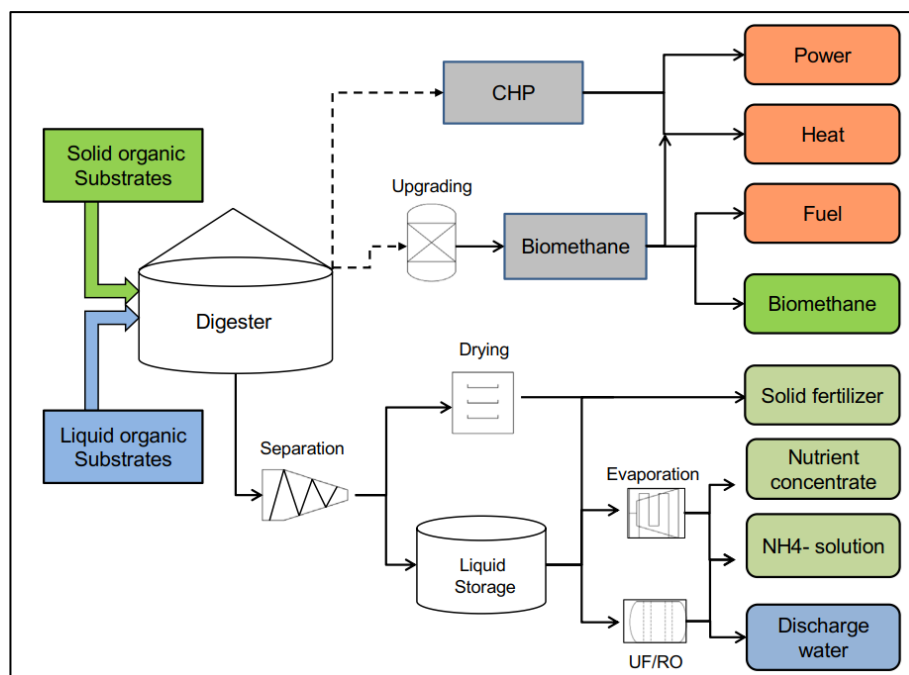

Figure 16. General Scheme of Biogas Biorefinery [1]

The product part (on the right) of Figure 16 is particularly noteworthy, with biogas being the key product. The most cost-effective solution is to utilize biogas directly in combined heat and power (CHP) systems to produce both electricity and heat from the exhaust gases. However, by upgrading the biogas to biomethane, it is possible to inject the media into the

grid or use it for compressed natural gas (CNG) vehicles. Additionally, biomethane has the potential to serve as a key chemical platform in the chemical industry. Methane can be used as a raw material to synthesize various critical substances such as ammonia, methanol, hydrogen, methyl halides, ethyne, carbon disulfide, and hydrocyanic acid [1].

The by-product of anaerobic fermentation, known as digestate, is typically used as a fertilizer in local agricultural fields. Discharging the nutrients stored in the digestate would not be economical or ecologically sustainable. However, digestate from wastewater treatment plants (WWTP) requires further separation of inorganic impurities such as plastics and metals, while digestate from agricultural biogas plants can be utilized without additional pre-treatment.

### 2.3.1 Biogas related patents

Biogas production is an open technology, meaning the companies which are building biogas plants have just their own confidential information regarding operating parameters or pre-treatments.

Nevertheless, there are patents in this area. Patent US20060102560 [58] has innovation to contact the slurry with biogas-producing bacteria for digestion under anaerobic conditions, and digesting slurry in the fermenter. Patent WO-A-2005/000748 [59] suggests to anaerobically hydrolyze material that has not been digested yet in fermenter to make the material available for biodegradation, which is not new nowadays.

Patent US 2010/0015680 A1 [60] describes complete process of biogas production in CSTR (Continuous Stirred Tank Reactor) with thermal pre-treatment step to make the lignocellulosic biomass more accessible for anaerobic digestion, where mesophilic conditions are used.

Patent WO 2010/046915 A2 [61], the object of the invention is to provide technique which uses mechanical and physical means to change floating nature of the agricultural residues. The solids settle down the digester which enables slurry to be easily pumped. Other objectives are to ensure better contact between biomass and the microbial culture media, and to reduce capital cost of the equipment.

US 9416373 B2 [62], inventors found that with help of the iron oxide nanoparticles during anaerobic fermentation can increase biogas production. Increase in the efficiency of biogas production results in a more cost-efficient process. From the Figure 1, presented in the patent

[62], can be found that after 35 days of holding time in digester, biogas yield can be increased by almost 300%.

US 9970032 B2 [63] describes the biorefinery concept of biogas production as secondary product and biodiesel as a key product, see Figure 17. From the grown cells the lipids are extracted by centrifuge. After lipids extraction, they are separated into different phases, where raw oil is converted to biodiesel by esterification, and spent cells together with water are used as a feedstock for anaerobic digestion. This is a relatively new patent, which shows that biorefinery is receiving higher attention.

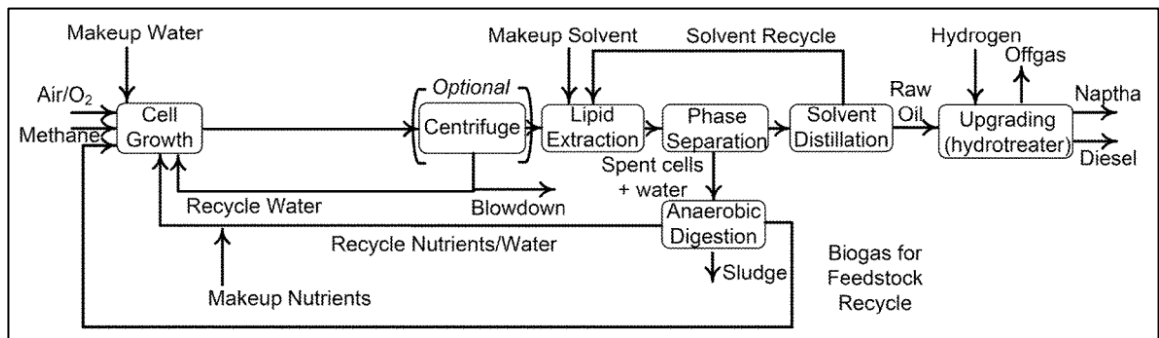

Figure 17. Schematic production of Patent US 9970032 B2 [63]

### 3. NEED FOR ACTION

The concept of biorefineries has garnered significant attention as a means of maximizing the utilization of renewable resources. To fully realize the potential of biorefineries, ongoing research efforts must be focused on developing sustainable biorefinery concepts and facilitating the transition from pilot and demonstration scale operations to commercial-scale implementation. The prioritization of biorefinery development is influenced by the relationships between countries, institutes, and government agencies, as well as their shared goals for promoting renewable bioenergy. As such, the following priorities have been identified as being of utmost importance [22].

- In deep research, development, and innovation within all biorefinery value chain, starting from feedstock and processes of primary and secondary refining, and going further up to the end products.
- Integration of suitable biomass conversion plants into existing biorefineries, with integrated material and energetic utilization of renewable resources.
- The further steps of biorefinery concepts from research scale to technical-, pilot-, demonstration- and finally to production scale, with the objective of ‘serial production’ in commercial facilities.
- To improve research collaborations towards the development of biorefineries at a European, and on an international level.
- To create international standards and consistent data basis for environmental life cycle analyses for biorefineries.

There are many suggestions about how to achieve sustainability. However, to face the problems, while trying to find a solution, is something what connects all of them. For the last decades there have been huge steps taken in the overall progress of biorefineries. Such a visualization gives us realistic promises about a sustainable future.

The commercialization of biorefineries is often predicted to begin once the availability of fossil fuels becomes limited. However, this assumption is often based on an erroneous comparison between biofuels and fossil fuels, without considering the environmental impact of their production and use. It is important to note that the combustion of biofuels and fossil fuels is not equivalent from an environmental perspective.

As discussed before, biorefineries focus mainly on the production of biofuels. Biochemical conversion is the main production technology and mechanical pretreatment is used mostly for the treatment of raw materials. Thus, it is necessary to evaluate techno-economic analysis for other biorefinery combinations and pretreatment methods.

## 4. OBJECTIVES

### *Hypothesis:*

Lignocellulosic waste treatment in biogas biorefinery producing simultaneously green chemicals and energies can meet industrial attractiveness independent on green subsidies.

### 4.1 General objectives

- To create a general parametric model of biogas biorefinery enabling a comparative evaluation of mass and energy balances, technical maturity, and design economics, including sensitivity analysis.
- To investigate an innovative technological set treating lignocellulosic biomass in biorefinery concept to reach investment attractiveness without any subsidies.

### 4.2 Specific objectives

- Design of brand-new biogas biorefinery that allows material-energy recycling of lignocellulosic waste tending to reach maximum waste conversion efficiency, minimum waste production, economically feasible, environmentally friendly, and CO<sub>2</sub> free.
- Creation of methodology to perform techno-economic analysis of designed paths; to prepare models /design process flow diagrams (PFD) of several paths including CO<sub>2</sub> free biogas plant configuration; to perform a case techno-economic studies; identification of crucial parameters affecting feasibility of the technology; environmental protection, risk analysis, financial support, and benefits.
- Creation of parametric simulation models for the proposed technological pathways.
- Verification of design suitability for industrial application – a decision of applicability in industry followed by sensitivity and strengths, weaknesses, opportunities, and threats (SWOT) analysis, effect of CO<sub>2</sub> release limitations, legislation, tasks for national/local government, product demand and quality, human resources.

## 5. MATERIALS AND METHODS

In Europe natural gas is used a lot for water heating facilities and production of electricity. Shortage of natural gas on the market rapidly increased prices of utilities. Biogas plant creates a platform which can compensate supply fluctuations. To increase the effectiveness of production it was decided to diversify key-products. Biomethane has high potential, it can be grid injected or used as CNG. Fiber is a relatively new product, whose potential needs to be investigated. Algae has diverse applicability, which makes it adaptable based on certain situations.

The original biogas biorefinery strategies are depicted in Figure 18. Based on combinatorics, following innovative biogas production technologies were proposed as presented in Table 7.

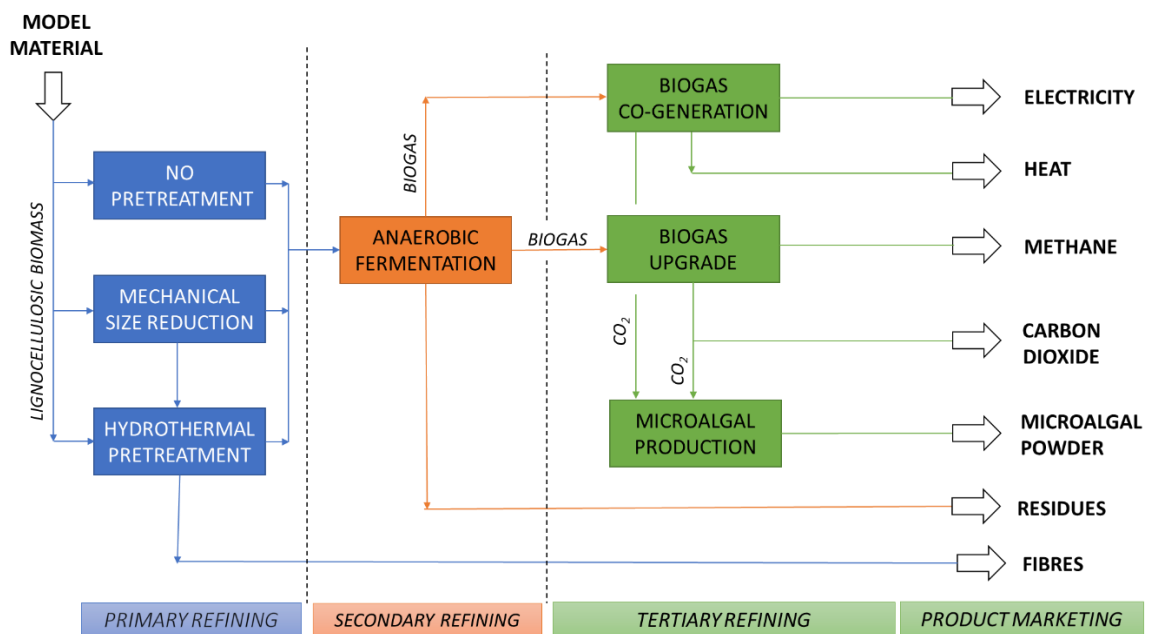

Figure 18. Biogas biorefinery strategies

There are six technologies described in the dissertation, see Table 7 [AK1] [AK2] [AK3] [AK4] [AK6] [AK8] [AK9] [AK10].

	Technology	Substrate	Products
1.	Conventional Biogas Plant	Wheat straw wastes	heat & electricity, residues
2.	Biogas upgrade		biomethane, residues
3.	Intensified Biogas Plant		heat & electricity, residues
4.	Biogas-Fiber Biorefinery		fiber, heat & electricity, residues
5.	Biogas-Algae Biorefinery		algae (autotrophic), heat & electricity, residues
6.	Biogas-Algae Biorefinery		algae (mixotrophic), heat & electricity, residues

Table 7. Overview of technologies

All the plants are new, there is no revamping case.

It is assumed that all plants are parts of existing agricultural farms. Thus, the availability of substrate is constant.

### 5.1 Design of technology and process set-up parameters

Each presented plant is designed with detailed mass and energy balances. The mass and energy balances were constructed based on process flow diagrams (PFD) and included into appendices. They were constructed and simulated using engineering practice, transport phenomena, and with the help of basic software. For all models, only wheat straw waste (next only wheat straw) is used as raw material. Substrate is collected in storage areas. In Table 8 are shown the pre-treatment methods which are used in different plants.

The location for all projects is not certain, but from the assumptions, surplus of raw material, more sunny days, countries with warm weather suits the best. It could be, Africa, South America, South Asia, or Australia.

Wheat straw waste is a by-product obtained after harvesting of wheat grains, and it has annual global production of 529 million tons [64]. Wheat straw wastes were chosen, because there is enough of reliable information about pre-treatment and fermentation process.

For all models, a mesophilic, +35 °C, process was assumed with hydrolyzer and one level fermentation stages. The residence time for biodegradation in the fermenter is 50 days. Only Biogas-fiber biorefinery has 20 days residence time, because suspension inside the fermenter is liquid mainly. For designing it was decided not to have 65-day residence time as applied in [65], because the best engineering practice shows that, with mechanical disintegration



only 50 days of residence time is sufficient [65] [49]. The fermenters are preheated with warm technological water, having minimum insulation thickness of 50mm, operated at 35 °C and designed for heat loss  $12.5 \text{ W m}^{-3}$  [49]. Fermenter and the homogenization vessel have agitators for mixing, which uniformly distribute the media inside. Electricity consumption of the agitator motors was considered for estimation of variable cost. Values of OLR, fermenter volume, CHP unit's installed electric power and the others, are presented in Table 31 (see in chapter 7). Fermenters are assumed to be made of concrete with heating coils.

To maintain constant flow of biogas, there is a buffer vessel between fermenter and CHP unit. Biogas and methane yields are described in Table 8. Normal conditions are 20 °C and 1 bar.

CHP unit has an electric efficiency of 38 % and a thermal efficiency of 45 %. [66]. For start-up and safe production, the surplus of biogas is burned in flares. Tail gases are cooled down in CHP, heated water is used for keeping process parameters in the other equipment.

From the beginning it was decided to consider small-size biogas plant to make it feasible on agriculture farms. CHP unit with electric power 500 kW<sub>el</sub> was chosen, as the most popular size of biogas plant in Europe. In Table 8 methane yield can be found. With help of Eq. (5) can be estimated mass flow rate of wheat straw.

$$\dot{Q} = \dot{m}_{TS} * \eta_E * q_{CH_4} * Y_{CH_4} \quad (5)$$

Where,

$q_{CH_4} = 9.94 \text{ kWh Nm}^{-3}$ , Combustion heat of methane.

$\dot{Q}$  [kW], Combustion heat of methane.

$Y_{CH_4}$  [Nm<sup>3</sup>t<sub>TS</sub><sup>-1</sup>], Methane yield.

$\eta_E$  [-], Efficiency for electricity production in cogeneration unit.

$\dot{m}_{TS}$  [kg s<sup>-1</sup>], Mass flow rate of *i* component (TS, total solids)

Based on Eq. (5), to produce 500 kW<sub>el</sub> in conventional plant it is necessary 0.545 t<sub>TS</sub> h<sup>-1</sup> or 0.152 kg<sub>TS</sub> s<sup>-1</sup> of wheat straw. To compare the difference of the techno-economical

estimations between the concepts, it was decided to fix the calculated mass flow rate and to use it for all the concepts.

As a product of biogas combustion in CHP unit, tail gases are released to atmosphere, but in biogas-algae biorefinery tail gases are used for cultivation. Tail gas produced by burning of biogas, consists of 66.1 % N<sub>2</sub>, 22.3 % CO<sub>2</sub>, 11.2 % H<sub>2</sub>O, and traces like NO<sub>x</sub> and CO [67] [68]. The post-rotting of the fermentation residues is not assumed, due to the carbon-poor residual solids, see Figure 12.

For digested fermentation residues, solid bowl decanter centrifuge was assumed to be used for liquid and solid separation process.

	Technology	Type of substrate pre-treatment	Solid concentration in homogenization vessel [%wt.]	Biogas yield [Nm <sup>3</sup> t <sup>-1</sup> TS]	Methane yield [Nm <sup>3</sup> t <sup>-1</sup> TS]	Reference
1.	Conventional Biogas Plant	No pre-treatment	10	509±58	243±49	[69], [AK3]
2.	Biogas upgrade	No pre-treatment	10	509±58	243±49	[69], [AK2]
3.	Intensified Biogas Plant	Thermal-expansive	5	633±52	362±43	[65], [AK2]
4.	Biogas-Fiber Biorefinery	Thermal-expansive	5	100	55	[65], [AK2]
5.	Biogas-Algae (autotrophic) Biorefinery	Mechanical disintegration	10	605±17	343±11	[70], [AK3]
6.	Biogas-Algae (mixotrophic) Biorefinery	Mechanical disintegration	10	605±17	343±11	[70], [AK3]

Table 8. Pre-treatment methods of substrate and biogas yield

### 5.1.1 Conventional biogas plant

A conventional biogas plant is a common type of biogas facility, where wheat straw residuals are typically not pre-treated prior to being sent to the fermenter. The substrate is first passed through a hydrolyzer, where it absorbs water, and this step can take up to 12 hours. The holding time in the fermenter depends on the feedstock, with untreated wheat

straw residuals requiring approximately 50 days to reach maximum biogas production yields [46]. The next stage is the separation of biogas from trace elements, followed by the combustion of biogas in CHP units. The residuals from the anaerobic fermentation process are then used as fertilizer for the cultivation of new plants.

### 5.1.2 Biogas Upgrade

For biogas upgrade no pretreatment was used, and biogas production section is completely same as in conventional plant.

Based on the assumption that biogas upgrade plant will be built in the farm, PSA separation method was chosen due to several critical reasons. From them are, it doesn't require water, as water scrubbing does, it is environmentally friendly, no chemicals are necessary, and it has high CH<sub>4</sub> purity.

PSA is a reliable separation technique, which is used in this thesis for biogas to biomethane upgrading. Besides CO<sub>2</sub>, other impurities such as H<sub>2</sub>S, NH<sub>3</sub> and H<sub>2</sub>O can be adsorbed. Nowadays, with pressure swing adsorption, the methane recovery of 96-98% (methane slip of 2-4%) can be achieved [56].

### 5.1.3 Intensified biogas plant

This concept has thermal-expansionary pre-treatment of feedstock [65], it is modern technology that can be used with different types of lignocellulosic biomasses. During this pre-treatment lignocellulosic biomass is held in the reactor, where high temperature steam and pressure is applied for few minutes. When residence time is achieved, the batch is depressurized. Liquid, which is absorbed by biomass pores, changes its phase from liquid to vapor, and the associated volumetric change causes a sudden disruption of the lignocellulosic bonds. The effectiveness of the steam expansion particularly depends on the particle size, its humidity and composition, on steam temperature and on residence time. Thus, substrate is mechanically treated in knifed screw conveyor [69] before entering to thermal pre-treatment section.

### 5.1.4 Biogas-fiber biorefinery

In biogas-fiber biorefinery thermal-expansionary is used as the pre-treatment method [65]. After pre-treated substrate is separated into solids (fiber) and liquid (juice) phases on perforated conveyor belt. Next follows natural drying of the wet fibers on the ground and

final drying in the drum. The obtained dried fiber material can be sold as insulation material or even can be used in reinforcing of polypropylene by substituting 30% of virgin polypropylene by wheat straw fiber [71]. Separated juice is used as the organic rich substrate for anaerobic digestion. Comparing to case when solid phase is being biodegraded, with juice digestion less biogas is produced. Residence time after which the highest yield is achieved is much shorter, that is because of easiness of organic availability. Digestate from fermenter can be sent into WWTP. Biogas is burned in CHP unit.

#### 5.1.5 Biogas-algae biorefinery

In this concept mechanical disintegration was used for the pre-treatment of feedstock. Warm water is mixed with wheat straw and subsequently milled; it is done to increase biodegradability of substrate in fermenter [70]. In the studied work [70], retting mill was used with roll diameter 300 mm, and it has operating capacity of 100-300 kg h<sup>-1</sup>. For this thesis needed capacity is 800-1000 kg h<sup>-1</sup>. So, it is assumed 1 retting mills with operating capacity 1000 kg h<sup>-1</sup>.

Produced biogas is burned in CHP unit to produce heat and electricity. By-products of combustion process, such as CO<sub>2</sub> and other traces, are used for algae cultivation. The influence of combustion exhausts on algae cultivation was studied by Doucha [67], it was proved that tail gasses from combustion of biogas doesn't inhibit the growth of *Chlorella Spirulina*. The authors [67] also calculated that it is possible to capture up to 20% of carbon dioxide emissions. Low content of NO<sub>x</sub> and CO in flue gasses doesn't negatively influence the growth of algae [67] [68]. The commercial algae production plant in Hawaii is already now using tail gasses from a small power plant as a source of carbon dioxide [72].

The algae species to be cultivated is *Chlorella vulgaris*. Yearly, more than 2000 tons (dry weight) of *Chlorella* is being produced, with the main producers being Germany, Japan, and Taiwan [73]. *Chlorella* can be grown under autotrophic, heterotrophic, and mixotrophic conditions [74]. One of the remarkable points for *Chlorella vulgaris* production is that it can grow both by performing photosynthesis and by ingesting organic materials such as glucose [74]. Nevertheless, with the mixotrophic technique, the production of dry biomass can be even more favorable, and a higher productivity is observed [75]. From the many types of open and closed systems of algae cultivation [5], one very interesting and promising photobioreactor (PBR) was chosen: the so-called co-annular PBR depicted in Figure 19, with general dimensions and light bulb configuration [76]. Author [76] declares 0.1841 g L<sup>-1</sup> day<sup>-1</sup>

<sup>1</sup> dry algae productivity for *Chlorella vulgaris* in the co-annular PBR. For being more realistic,  $0.150 \text{ g L}^{-1}\text{day}^{-1}$  dry algae productivity would be applied for both the autotrophic and mixotrophic techniques, dismissing the possible higher productivity with the heterotrophic technique [74].

For *Chlorella vulgaris* cultivation, Bold's basal medium (BBM) as a nutrient is used [76]. For autotrophic growth, BBM nutrients are added to the PBR every 3<sup>rd</sup> day [76]. Since less light is used for mixotrophic growth, it is assumed that nutrients should be added more often, i.e. every 2<sup>nd</sup> day. For 1L of media inside the PBR it is needed, 0.705 g of BBM, and 1.0 mL of 0.1% Sulfuric Acid is needed [77]. In this thesis, the operating volume of one PBR is 258 L.

The selling prices of high-value algae, like Chlorella, is relatively high on the market. High-value algae can be used for human nutrition, cosmetics, and aquaculture applications. It is expected that the price of Chlorella will only decrease in the future.

The only things which relate autotrophic and mixotrophic techniques are dark/light ratio and the periodicity of consumables dosing. The potential interest of algae biomass is huge. Algae can be used as the substrate for biofuels production, human nutrition, animal feed, wastewater treatment, and agrochemical applications [74].

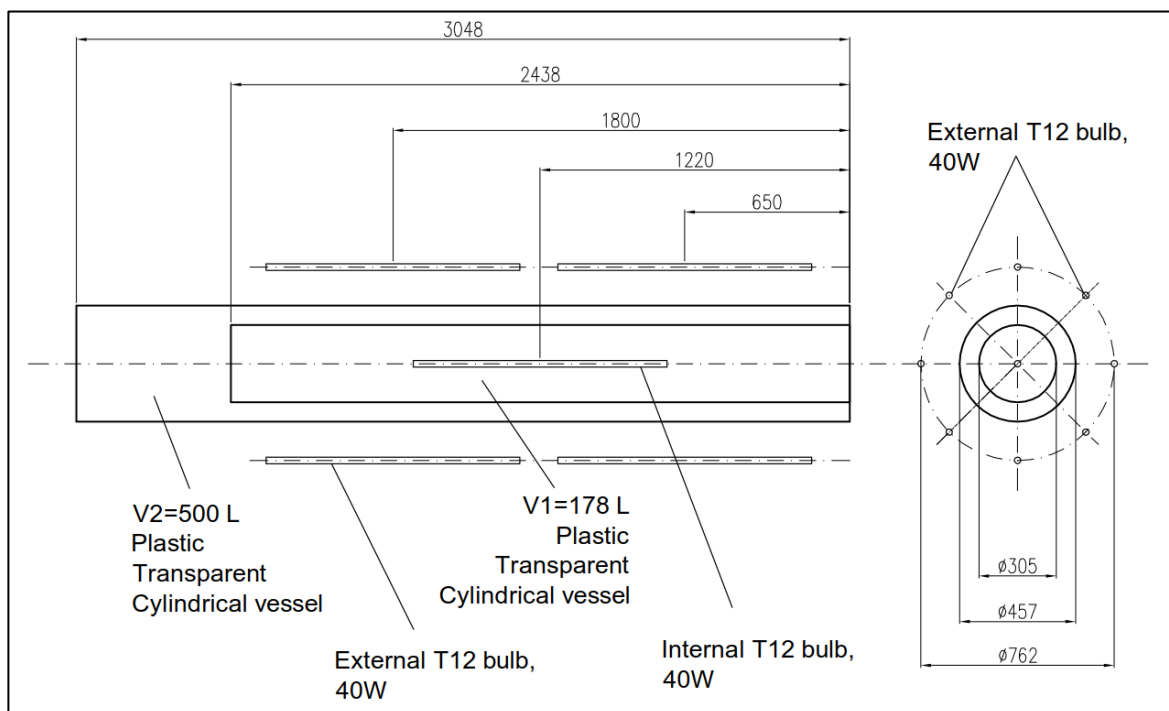

Figure 19. Co-annular PBR [76]

## 5.2 Parametric model

Below are parametric models for individual processes, which were used for mass and energy balance estimations. Each parametric model has block diagram and list of used symbols.

### 5.2.1 Block ID1: Mechanical size reduction

Mechanical size reduction represents mechanical pretreatment of the substrate. Mechanical pretreatment was used in intensified BP, biogas-fiber, and biogas-algae biorefineries.

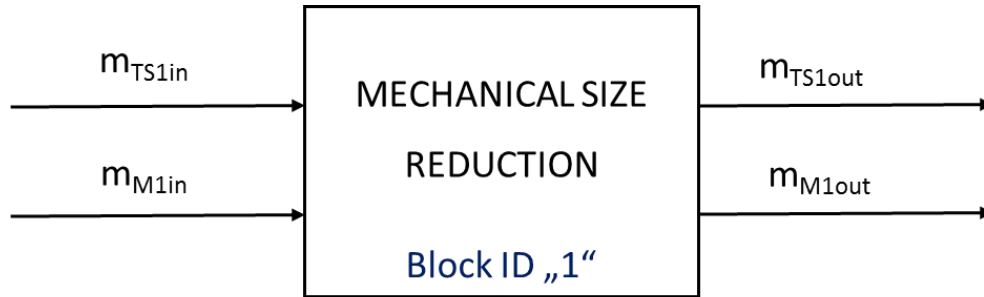

Figure 20. Mechanical size reduction, block diagram

Where,

$C_{TS}^m$  – mass fraction of total solids (residuals) [% wt.]

$C_R$  – energy constant [ $\text{kWh mm}^{-1} \text{t}^{-1}$ ]

$D_i$  – diameter of milling wheel [mm]

$e$  – energy demand [ $\text{kJ t}^{-1}$ ]

$m_{TS1in}$  – wheat straw inlet [ $\text{kg s}^{-1}$ ]

$m_{M1in}$  – moisture inlet [ $\text{kg s}^{-1}$ ]

$m_{TS1out}$  – wheat straw outlet [ $\text{kg s}^{-1}$ ]

$m_{M1out}$  – water outlet [ $\text{kg s}^{-1}$ ]

$P$  – power [kW]

$M$  – moisture

$TS$  – total solids

Mass balance equations:

$$\dot{m}_{TS1in} = c_{TS1in}^m * \dot{m}_{in} \quad (6)$$

$$\dot{m}_{M1in} = \dot{m}_{in} - \dot{m}_{TS1in} \quad (7)$$

$$\dot{m}_{TS1out} = \dot{m}_{TS1in} \quad (8)$$

$$\dot{m}_{M1out} = \dot{m}_{M1in} \quad (9)$$

Energy demand:

$$e = \frac{P}{\dot{m}} = C_R * \left( \frac{1}{D_{OUT}} - \frac{1}{D_{IN}} \right) \quad (10)$$

### 5.2.2 Block ID2: Hydrothermal pretreatment

Hydrothermal pretreatment represents thermal-expansionary pretreatment. It is used in intensified BP and biogas-fiber biorefinery.

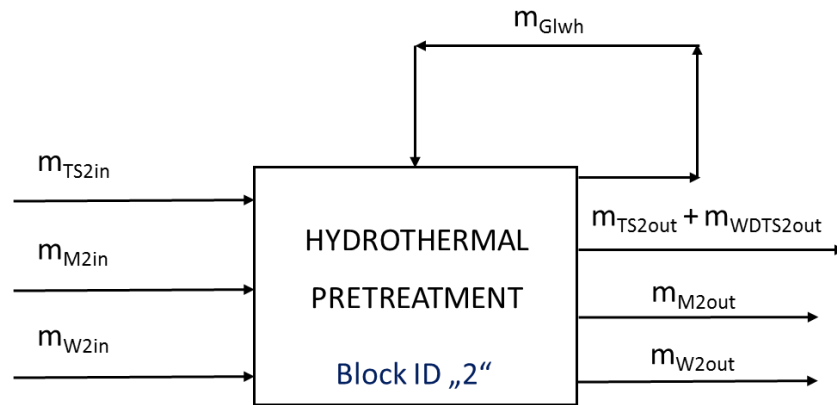

Figure 21. Hydrothermal pretreatment, block diagram

Where,

$C_p$  - specific heat capacity at constant pressure [ $\text{kJ kg}^{-1} \text{K}^{-1}$ ]

$C_{LCM2}^m$  – mass fraction of biomass concentration in inlet stream [% wt.]

$L_{V100}$  – latent heat of evaporation or condensation with batch decompression at  $100^\circ\text{C}$  at atmospheric pressure [ $\text{kJ kg}^{-1}$ ]

$m_{TS2in}$  – wheat straw inlet [ $\text{kg s}^{-1}$ ]

$m_{M2in}$  – moisture inlet [ $\text{kg s}^{-1}$ ]

$m_{W2in}$  – water inlet [kg s<sup>-1</sup>]

$m_{Glwh}$  – water vapors inlet [kg s<sup>-1</sup>]

$m_{TS2out}$  – wheat straw outlet [kg s<sup>-1</sup>]

$m_{WDTS2out}$  – water dissolved wheat straw outlet [kg s<sup>-1</sup>]

$m_{M2out}$  – moisture outlet [kg s<sup>-1</sup>]

$m_{W2out}$  – water outlet [kg s<sup>-1</sup>]

$\dot{Q}$  – heat [kW]

$T_{W2}$  – working temperature [K]

$T_{INIT}$  – initial batch temperature [K]

$T_{FIN}$  – out bath temperature after decompression and cooling [K]

$\alpha_{TS}$  – amount of dissolved wheat straw during pretreatment process [% wt.]

TS – total solids

M – moisture

W – water

WDTS – water dissolved total solids

Overall mass balance:

$$\dot{m}_{TS2in} + \dot{m}_{M2in} + \dot{m}_{W2in} + \dot{m}_{Glwh} = \dot{m}_{TS2out} + \dot{m}_{WDTS2out} + \dot{m}_{M2out} + \dot{m}_{W2out} \quad (11)$$

Individual mass flow balance:

$$\dot{m}_{TS2in} = \dot{m}_{TS2out} + \dot{m}_{WDTS2out} \quad (12)$$

$$\dot{m}_{M2in} = \dot{m}_{M2out} \quad (13)$$

Biomass concentration in inlet stream:



$$\dot{m}_{2in} = \dot{m}_{TS2in} + \dot{m}_{M2in} + \dot{m}_{W2in} + \dot{m}_{Glwh} \quad (14)$$

$$C_{LCM2}^m = \frac{\dot{m}_{TS2in} + \dot{m}_{M2in}}{\dot{m}_{TS2in} + \dot{m}_{M2in} + \dot{m}_{W2in} + \dot{m}_{Glwh}} \quad (15)$$

Conversion of total solid to water (dissolved in water due to boiling):

$$\alpha_{TS} = 1 - \frac{\dot{m}_{TS2out}}{\dot{m}_{TS2in}} \quad (16)$$

Output mass balance:

$$\dot{m}_{2in} = \dot{m}_{TS2out} + \dot{m}_{WDTS2out} + \dot{m}_{W2out} + \dot{m}_{M2out} + \dot{m}_{Glwh} \quad (17)$$

$$\dot{m}_{WDTS2out} = \alpha_{TS} * \dot{m}_{TS2in} \quad (18)$$

$$\dot{m}_{TS2out} = (1 - \alpha_{TS}) * \dot{m}_{TS2in} \quad (19)$$

$$\dot{m}_{Glwh} = \dot{m}_{2in} * \left( \frac{c_{Pbatch} * (T_{W2} - T_{INIT}) - c_{PH2O} * (100 - T_{FIN})}{LV_{100} - c_{PH2O} * (100 - T_{FIN})} \right) \quad (20)$$

Energy balance:

$$\dot{Q}_2 = \dot{m}_{2in} * c_{Pbatch} * (T_{W2} - T_{INIT}) \quad (21)$$

### 5.2.3 Block ID3: Anaerobic fermentation

Anaerobic fermentation represents fermentation process of wheat straw. It is used in every concept.

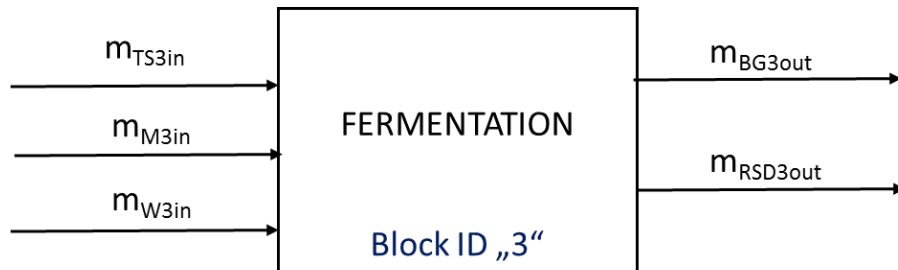

Figure 22. Fermentation, block diagram

Where,

c – wheat straw to biogas conversion amount [% wt.]

$m_{TS3in}$  – wheat straw inlet [kg s<sup>-1</sup>]

$m_{M3in}$  – moisture inlet [kg s<sup>-1</sup>]

$m_{W3in}$  – water inlet [kg s<sup>-1</sup>]

$m_{BG3out}$  – produced biogas [kg s<sup>-1</sup>]

$m_{RSD3out}$  – fermentation residuals [kg s<sup>-1</sup>]

$Y_{CH_4}$  – methane yield [ $Nm^3 t_{TS}^{-1}$ ]

BG – biogas

COD – Chemical oxygen demand

M – moisture

RSD – residuals

W – water

$x, y, z$  – number of atoms of each element

Wheat straw to biogas conversion amount:

$$c = \frac{\dot{m}_{BG3out}}{\dot{m}_{TS3in}} \quad (22)$$

$$\dot{m}_{BG3out} = c * \dot{m}_{TS3in} \quad (23)$$

Overall mass flow balance:

$$\dot{m}_{TS3in} + \dot{m}_{M3in} + \dot{m}_{W3in} = \dot{m}_{BG3out} + \dot{m}_{RSD3out} \quad (24)$$

General stoichiometry equation for methane creation:

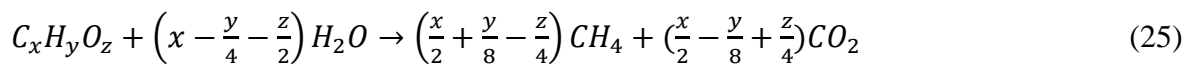

Theoretical yield of methane from the given substrate:

$$Y_{CH_4g} = 0.35 * COD \left[ \frac{l(0^\circ C, 1 atm)}{g} \right] (CH_4, substrate) \quad (26)$$

#### 5.2.4 Block ID4: Digestate treatment

Digestate treatment represents separation of solid and liquid phase in centrifuge. Centrifuge was in all concepts beside biogas-fiber biorefinery.

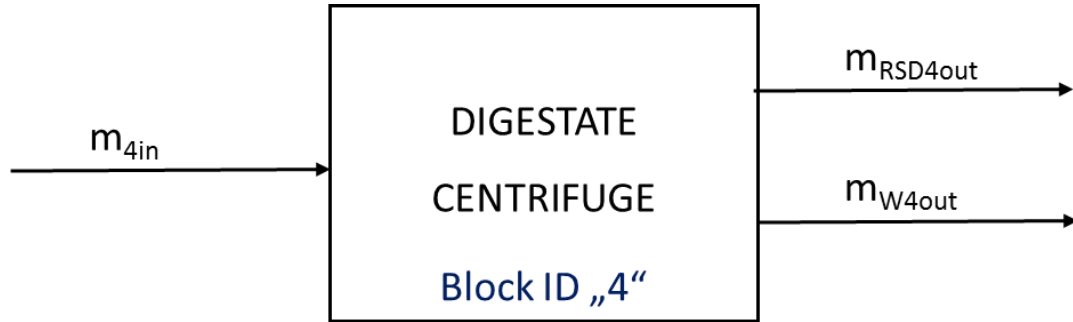

Figure 23. Digestate centrifuge, block diagram

Where,

$C_4^m$  – mass fraction of total solids (residuals) [% wt.]

$m_{4in}$  – fermented residuals inlet [ $\text{kg s}^{-1}$ ]

$m_{RSD4out}$  – separated solids outlet [ $\text{kg s}^{-1}$ ]

$m_{W4out}$  – separated liquid outlet [ $\text{kg s}^{-1}$ ]

$\eta_{TS}$  – total solids separation efficiency [-]

$\eta_W$  – total water separation efficiency [-]

RSD – residuals

TS – total solids

W – water

Overall mass flow balance:

$$\dot{m}_{4in} = \dot{m}_{RSD4out} + \dot{m}_{W4out} \quad (27)$$

Individual mass flow balance:

$$\dot{m}_{4in} = \dot{m}_{TS4in} + \dot{m}_{M4in} + \dot{m}_{W4in} \quad (28)$$

$$\dot{m}_{RSD4out} = \dot{m}_{TS4out} + \dot{m}_{M4out} \quad (29)$$

Solid separation efficiency with decanter centrifuge:

$$\dot{m}_{TS4out} = \dot{m}_{TS4in} * \eta_{TS} \quad (30)$$

Separated water:

$$\dot{m}_{W4out} = \dot{m}_{W4in} * \eta_W \quad (31)$$

### 5.2.5 Block ID5: Biogas combustion

Biogas combustion represents combustion in internal combustion engine in CHP unit. CHP unit applied in all concepts beside biogas upgrade.

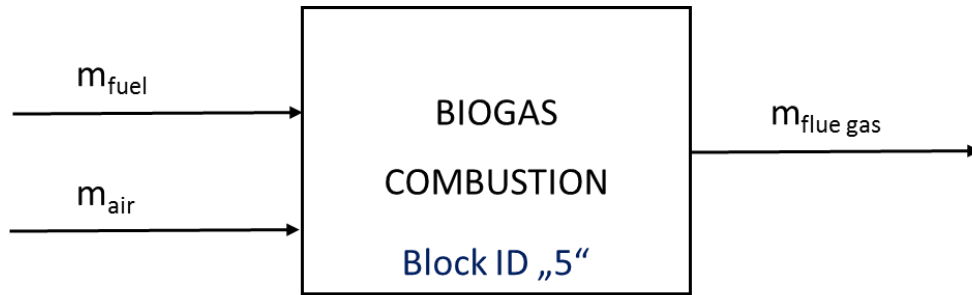

Figure 24. Biogas Combustion, block diagram

Where,

$m_{fuel}$  – methane and traces of carbon dioxide inlet [ $kg\ s^{-1}$ ]

$m_{air}$  – air inlet [ $kg\ s^{-1}$ ]

$m_{flue\ gas}$  – flue gasses outlet [ $kg\ s^{-1}$ ]

$m_{TS}$  – mass flow of total solids [ $kg\ s^{-1}$ ]

$q_{CH_4}$  – Combustion heat of methane [ $kWh\ Nm^{-3}$ ]

$\dot{Q}$  – Combustion heat of methane [ $kW$ ]

$Y_{CH_4}$  – methane yield [ $Nm^3 t_{TS}^{-1}$ ]

$\eta_E$  – efficiency for electricity production in cogeneration unit [-]

Basic combustion reaction:



Overall mass flow balance:

$$\dot{m}_{flue\ gas} = \dot{m}_{fuel} + \dot{m}_{air} \quad (33)$$

$$\dot{m}_{air} = \dot{m}_{oxygen} + \dot{m}_{nitrogen} + \dot{m}_{traces} \quad (34)$$

Air surplus (+25%):

$$\dot{m}_{oxygen} = 2.5 * \dot{m}_{methane} \quad (35)$$

Electricity production with methane combustion:

$$\dot{Q} = \dot{m}_{TS} * \eta_E * q_{CH_4} * Y_{CH_4} \quad (36)$$

### 5.2.6 Block ID6: Biogas upgrade

Biogas upgrade represents pressure-swing adsorption unit (PSA). PSA is used only in biogas upgrade concept.

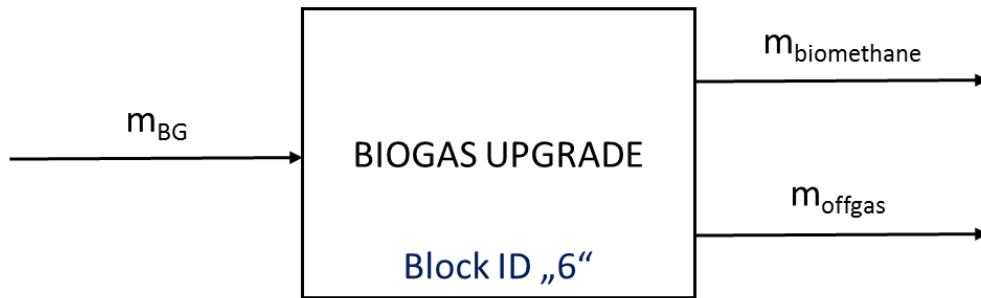

Figure 25. Biogas upgrade, block diagram

Where,

$b_i$  – single component temperature-dependend parameter [mol kg<sup>-1</sup>]

$k$  – isentropic coefficient [-]

$k_{q,i}$  – Langmuir parameter, coefficient of zeolite 5A [mol kg<sup>-1</sup> K<sup>-1</sup>]

$k_{b,i}$  - Langmuir parameter, coefficient of zeolite 5A [K]

$m_{BG}$  – biogas inlet [kg s<sup>-1</sup>]

$m_{biomethane}$  – biomethane outlet [kg s<sup>-1</sup>]

$m_{offgas}$  – offgas outlet [kg s<sup>-1</sup>]

$n$  – molar flow rate [mol s<sup>-1</sup>]

$P$  – power [kW]

$p_i$  – partial pressure of  $i$  component [bar]

$R$  – universal gas constant [J mol<sup>-1</sup> K<sup>-1</sup>]

$T$  – temperature [K]

$q_i$  – absorbed phase concentration of  $i$  component [mol kg<sup>-1</sup>]

$q_{max,i}$  – single component temperature-depended parameter [mol kg<sup>-1</sup>]

$\eta_{mech}$  – mechanical efficiency [-]

BG - biogas

Overall mass flow balance:

$$\dot{m}_{BG} = \dot{m}_{biomethane} + \dot{m}_{offgas} \quad (37)$$

Multicomponent Langmuir Isotherm:

$$\frac{q_i}{q_{max,i}} = \frac{b_i * p_i}{1 + \sum b_j * p_j} \quad (38)$$

$$q_{max,i}(T) = q_{max,i}(298 K) + k_{q,i}(T - 298) \quad (39)$$

$$b_i(T) = b_i(298 K) * \exp(k_{b,i} \left( \frac{1}{T} - \frac{1}{298} \right)) \quad (40)$$

Energy consumption during biogas single stage compression (adiabatic regime):

$$P = \frac{k}{k-1} \frac{RT}{\eta_{mech}} \dot{n} \left[ \left( \frac{p_{out}}{p_{in}} \right)^{\frac{k-1}{k}} - 1 \right] \quad (41)$$

### 5.2.7 Block ID7, ID8: Algae cultivation and harvesting

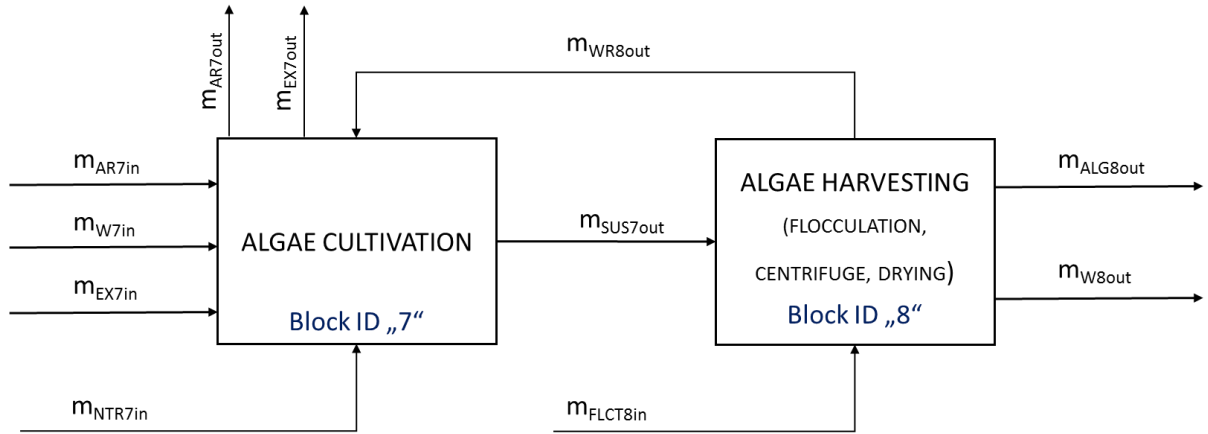

Figure 26. Algae cultivation and harvesting, block diagram

Where,

$m_{AR7in}$  – air inlet [ $kg\ s^{-1}$ ]

$m_{AR7out}$  – air outlet [ $kg\ s^{-1}$ ]

$m_{EX7in}$  – cooled exhaust inlet [ $kg\ s^{-1}$ ]

$m_{EX7out}$  – exhaust outlet [ $kg\ s^{-1}$ ]

$m_{W7in}$  – water inlet [ $kg\ s^{-1}$ ]

$m_{NTR7in}$  – nutrients inlet [ $kg\ s^{-1}$ ]

$m_{WR8out}$  – return water [ $kg\ s^{-1}$ ]

$m_{SUS7out}$  – suspension inlet [ $kg\ s^{-1}$ ]

$m_{FLCT7in}$  – flocculant inlet [ $kg\ s^{-1}$ ]

$m_{ALG8out}$  – high-value algae outlet [ $kg\ s^{-1}$ ]

$m_{W8out}$  – water outlet [ $kg\ s^{-1}$ ]

ALG – algae

AR – air

CNTF – centrifuge

DRN – drying

EX – exhausts

FLCT – flocculant

M – moisture

NTR – nutrients

SUS – suspension

W – water

WR – returned water

Overall mass flow balance:

$$\dot{m}_{AR7in} + \dot{m}_{W7in} + \dot{m}_{EX7in} + \dot{m}_{WR8out} + \dot{m}_{NTR7in} = \dot{m}_{SUS7out} + \dot{m}_{AR7out} + \dot{m}_{EX7out} \quad (42)$$

$$\dot{m}_{SUS7out} + \dot{m}_{FLCT8in} = \dot{m}_{ALG8out} + \dot{m}_{W8out} + \dot{m}_{WR8out} \quad (43)$$

Individual mass flow balance:

$$\dot{m}_{ALG7out} = \dot{m}_{FLCT,ALG8out} = \dot{m}_{CNTF,ALG8out} = \dot{m}_{DRN,ALG8out} \quad (44)$$

$$\dot{m}_{M7out} = \dot{m}_{FLCT,M8out} = \dot{m}_{CNTF,M8out} \quad (45)$$

Algae mass flow after cultivation:

$$\dot{m}_{SUS7out} = \dot{m}_{ALG7out} + \dot{m}_{M7out} + \dot{m}_{W7out} \quad (46)$$

$$C_{ALG7out}^m = \frac{\dot{m}_{ALG7out} + \dot{m}_{M7out}}{\dot{m}_{SUS7out}} \quad (47)$$

Algae mass flow after flocculation (harvesting):

$$\dot{m}_{FLCT,SUS8out} = \dot{m}_{FLCT,ALG8out} + \dot{m}_{FLCT,M8out} + \dot{m}_{FLCT,W8out} \quad (48)$$



$$C_{FLCT,ALG8out}^m = \frac{\dot{m}_{FLCT,ALG8out} + \dot{m}_{FLCT,M8out}}{\dot{m}_{FLCT,SUS8out}} \quad (49)$$

Algae mass flow after centrifuge (harvesting):

$$\dot{m}_{CNTF,SUS8out} = \dot{m}_{CNTF,ALG8out} + \dot{m}_{CNTF,M8out} + \dot{m}_{CNTF,W8out} \quad (50)$$

$$C_{CNTF,ALG8out}^m = \frac{\dot{m}_{CNTF,ALG8out} + \dot{m}_{CNTF,M8out}}{\dot{m}_{CNTF,SUS8out}} \quad (51)$$

Algae mass flow after drying (harvesting):

$$\dot{m}_{ALG8out} = \dot{m}_{DRN,ALG8out} + \dot{m}_{DRN,M8out} \quad (52)$$

$$C_{DRN,ALG8out}^m = \frac{\dot{m}_{ALG8out}}{\dot{m}_{ALG8out} + \dot{m}_{W8out}} \quad (53)$$

Returned water from harvesting to algae cultivation:

$$C_{WR8}^m = \frac{\dot{m}_{WR8out}}{\dot{m}_{W7in}} \quad (54)$$

Consumed air for algae cultivation:

$$C_{AR7}^m = \frac{\dot{m}_{AR7out}}{\dot{m}_{AR7in}} \quad (55)$$

Consumed exhausts for algae cultivation:

$$C_{EX7}^m = \frac{\dot{m}_{EX7out}}{\dot{m}_{EX7in}}$$

(56)

## 5.3 Economic evaluation technique

### 5.3.1 Capital cost estimation

Fixed capital investment is the sum of designing, construction, commissioning, start-up and the other costs, which are necessary to build and hand over the plant. It is consisting of [78]:

- The inside battery limit (ISBL) investment,
- The outside battery limit (OSBL) investment,
- Engineering and construction costs,
- Contingency charges.

The ISBL cost includes the costs of procuring and installing all the process equipment that makes up a new plant. Here also included piping, instruments, civil, painting, insulation, etc.

Beside direct field costs, indirect field costs include all kind of tools during construction, construction insurance, labor benefits, logistics, etc. [78].

The estimation of ISBL costs is very important at the beginning of the project because the other costs are strongly dependent on ISBL costs.

OSBL investment is the additions that shall be made to the site infrastructure to accommodate adding a new plant or increasing capacity of the existing. OSBL includes, substations, turbine engines, boilers, cooling towers, circulation pumps, pipe racks, conveyors, laboratories, offices, lay down areas, workshops, etc. [78].

OSBL costs are estimated as a portion of ISBL costs during basic design. For chemical industries OSBL is usually 20-50% of ISBL cost, and 40% is taken when no details of the site are known [78].

Once a site has been chosen, the modifications based on the site infrastructure can be designed with better precision. Thus, OSBL cost can be corrected.

The engineering costs, also known as contractor charges, include the costs of detailed design and other engineering services, which are required to carry out the project. That includes, detailed design of equipment, piping, instruments, civil engineering, procurement, construction supervision, administrative charges, contractors' profit [78].

Engineering costs are better estimated individually because they are not directly proportional to project size. Rule of thumb for engineering costs is 30% of ISBL plus OSBL costs for smaller projects and 10% of ISBL plus OSBL for larger projects [78].

Contingency charges are the extra costs associated with variation of cost estimate. All cost estimations are uncertain, and the final installed cost of project can be known only after installation is completed. It includes currency fluctuations, labor disputes, subcontractor problems, etc. [78].

Usually, a minimum contingency charge of 10% of ISBL plus OSBL shall be used for the project. If the technology is not well-known, contingency charges could rise to 50% [78].

To fixed capital investment, which is used to design and construct the plant, the owner should also invest some capital for the plant maintenance. The capital that comprises of maintaining inventories of feeds, products, and spare parts, including cash on hand and difference between money owed by costumers and money owed by suppliers, is said to be working capital of the plant [78]. Working capital is necessary when the plant is in operation, but it is recovered when the plant is shut down.

### 5.3.2 Estimating purchased equipment costs

When the project has enough design information, the cost of the plant can be estimated from the cost of each individual process equipment.

The best estimation of the cost of the equipment is based on prices paid for similar equipment. Such a database usually has EPC (Engineering Procurement and Construction) companies, but this information is strictly confidential. Thus, design engineers who are outside of EPC sectors could use cost data from the open source or to use cost estimating software. The most powerful software with a wide database is owned by Aspen Technology Inc., called Aspen ICARUS Technology. However, the license of this software is not easily accessible by design engineers.

For design engineers who doesn't have reliable cost data or software Eq. (57) can be used for preliminary estimation [78],

$$C_e = a + bS^n \quad (57)$$

where,

$C_e$  – Purchased equipment cost on U.S Gulf Coast basis

$a, b$  – cost constants as per [78]

$S$  – size parameter as per [78]

$n$  – exponent for that type of equipment

There are equipment, which are not standard like, cogeneration unit or huge anaerobic fermenters, for which the specific cost could be found in terms of \$ kW<sub>el</sub><sup>-1</sup> or \$ m<sup>-3</sup> respectively.

All cost estimating methods use historical data. Hence, during estimation cost escalation should be considered. Chemical Engineering Plant Cost Index (CEPCI) is the index for the

United States which is published monthly in the journal *Chemical Engineering*. Nelson-Farrer Refinery Construction Index (NF index) is used for oil refinery and petrochemical projects.

U.S. Gulf Coast or Northwest Europe are historically the centers of the chemical industry, for them more data are available. Thus, cost data shall also be correlated with location factor [78].

### 5.2.3 Estimating Production Costs

Estimation of plant revenue and cost of production is a key step in defining the feasibility of the project. The better technology is known, the more precise estimation is. The companies with experience in EPC project can define the revenues and production costs even with higher accuracy.

Variable Cost of Production is directly proportional to the output of a plant [78]. It includes,

- Feedstock material,
- Utilities,
- Consumables (additives, adsorbents, etc.),
- Effluent disposal,
- Packing and transportation.

Usually, chemical plants should have the ability to cover 70-110% of plant capacity production range.

Fixed Cost of Production is not influenced by a plant output. So, even if the plant is not in operation this cost shall be covered accordingly [78]. It includes,

- Operating labor,
- Supervision, usually it is 25% of operating labor,
- Direct salary overhead, usually it is 40-60% of operating labor and supervision,
- Maintenance, which includes material and labor, and it is 3-5% of ISBL investment. The more plant has rotary equipment the higher maintenance cost would be,
- Property taxes and insurance, usually it is 1-2% of ISBL investment,
- Rent of land, usually it is 1-2% of ISBL and OSBL investment. However, if the land is bought it is added to fixed capital investment,

- General plant overhead, it covers human resources, research and development, finance, etc.
- Allocated environment charges to cover superfund payments, it usually 1% of ISBL and OSBL investment,
- License fees and royalty payment,
- Capital charges, it is interest payments due to debt or loans which are used for project financing. However, when budget of the owner is enough to cover fixed capital investment capital charges are zero,
- Sales and marketing costs, this expense depends absolutely on the owner strategy. Depending on the product, the better marketing, the more chances to sell the product. However, if the product already has permanent customers the expense could be less.

Fixed costs should be every time considered from the earliest stage of estimation because it can have a significant impact on project economics.

#### 5.2.4 Revenues, Margins and Profits

Revenues are the income which is earned by selling products and by-products of the plant. Based on plant production capacity the revenues could differ annually.

The gross margin is the sum of product and by-product revenues subtracted by raw material cost. Such a notation is used, because usually raw material cost almost always contributes to the largest part of production cost. That is why, sometimes producers must increase the price of a product to keep the same margin, when feedstock price is growing. Another notation is variable contribution margin, which is revenue minus variable cost, it indicates the profitability of the process on a fixed-cost-free basis [78].

The sum of fixed (FCOP) and variable production costs (VCOP) is cash cost of production (CCOP). It is the cost of making the product. Sometimes, by-product revenues are taken as a credit and included in VCOP. It makes it easier to determine \$ kg<sup>-1</sup> cost of produced main product.

Gross profit is the main product revenues minus CCOP. So that, it includes all variable costs in addition to raw material and includes fixed costs and by-product revenues.

The profit which is made by plant is always subjected to taxation unless it has some economical support. The net profit is the amount left after taxes paid. From the net profit the payback period could be estimated, as it is the return of initial investments.

It is sometimes useful to estimate the total cost of production (TCOP) if a plant generates a specified return on investment. TCOP is CCOP plus annual capital charge (ACC).

### 5.2.5 Discounted cash flow rate of return (Discounted payback period)

To consider time value of money and for annual variation of expenses and revenues, the discounted cash flow rate of return is presented. It can also be called discounted payback period, next only payback. With net present value (NPV) at various interest rates, it is possible to find an interest rate at which the cumulative NPV at the end of the project is zero, see Eq. (58) [78].

$$\sum_{n=1}^{n=t} \frac{CF_n}{(1+i')^n} = 0 \quad (58)$$

where,

$CF_n$  – cash flow in year  $n$

$t$  – project life in years

$i'$  – the discounted cash flow rate of return (percent/100)

Discounted cash flow of return provides practical way of comparing the performance of capital for different projects, which is independent of the amount of capital used, lifetime of the plant, or the actual interest rates prevailing at any time [78].

Discounted cash flow of return can be compared directly with interest rates. Thus, it is sometimes known as the interest rate of return (IRR) [78].

### 5.2.6 Economic model set-up

This chapter describes the parameters which were taken during economic analysis. From the Table 9 below it is possible to see all applied costs, percentage for each type of calculation taken.

The values used for economic set-up are taken as per the year 2014/2015, because at this time all concepts and calculations appeared. Same coefficients were used in author's impacted articles and conference proceedings [AK1] [AK2] [AK3] [AK4] [AK6] [AK8] [AK9] [AK10].

US dollar is chosen for economic evaluation due to its prevailing transactions on the global market.

For defining of electricity selling price Renewable Energy Sources Act [79] was used. Where is stated that for electricity from installations using biogas, which is gained from anaerobic fermentation of biomass, can be sold for 14.88 euro cents per kilowatt-hour up rated capacity 500 kW and 13.05 euro cents per kilowatt-hour up to rated capacity 20 MW. Other benefits (market premium, green feed-in tariff, etc.) pursuant to Section 19 of [79] cannot be used, unless renewable energy plant connected to a device for post-rotting of fermentation residues and material of the post-rotted fermentation residues is recycled. For this thesis electricity selling price is assumed to be  $0.157 \text{ \$ kWh}^{-1}$ , which will be used in every renewable energy plant.

The selling price of the biomethane produced from the anaerobic fermentation and upgraded in the pressure swing adsorption (PSA) unit is in between  $0.108 \text{ \$ kWh}^{-1}$  or  $0.1 \text{ € kWh}^{-1}$ , referring to the low heating value of methane of  $50 \text{ MJ kg}^{-1}$ ,  $10 \text{ kWh m}_N^{-3}$  [80].

For biogas upgrade and biogas-algae biorefinery concepts, electricity is supplied as the utility. On 2<sup>nd</sup> half of 2015 price of electricity was  $0.13 \text{ \$ kWh}^{-1}$  [81].

Water is one of the plant utilities. Average price of  $1 \text{ m}^3$  in Europe is  $3 \text{ \$}$  [82].

The price of fiber was only predicted to be  $185 \text{ \$ t}^{-1}$ . The real aim of the fiber could be quite diverse, so as the price. In case dry fiber shall be used as the insulation material, the market competitor, mineral wool, is sold for approximately  $1500 \text{ \$ t}^{-1}$  [83].

Price of *Chlorella Spirulina* is estimated to be  $45 \text{ \$ kg}^{-1}$  [84].

Low-pressure steam (LPS) shall be supplied to plant battery limit for the price  $13 \text{ \$ t}^{-1}$  [85]. Comparing to middle- and high-pressure steam, low-pressure steam has lower price value and higher availability.

Average salary in Europe is approximately  $1631 \text{ \$ per month}$  [86]. However, salaries in small cities, where agriculture farms are usually built, are smaller. Thus, assumed salary is  $1300 \text{ \$ per month}$  or  $15600 \text{ \$ annually}$ .

The weighted average of the cost of debt and the cost of equity is 5%. It also can be called cost of capital. The overall cost of capital sets the interest rate that is used in economic evaluation of the projects.

Average tax rate in Europe is 19% [87]. So, this value shall be used in this thesis.

The field for construction of all the concepts is assumed to be owned by farm owners.

Each plant shall operate 8000 hours annually, beside biogas-algae biorefinery which will operate 7500 hours. A big quantity of PBRs shall need more time for maintenance annually, that is why operating hours of biogas-algae biorefinery are lower.

The lifetime of all the concepts is 15 years.



	Conventional BP		Biogas upgrade	Intensified BP	Biogas-Fiber Biorefinery	Biogas-Algae Biorefinery	Biogas-Algae Biorefinery	
Raw material	Wheat straw [\$ t <sup>-1</sup> ]							
Key-product	Electricity [\$ kWh <sup>-1</sup> ]	0.157 [79]	N/A	0 (free, taken from local farm)				0.157 [79]
	Biomethane [\$ kWh <sup>-1</sup> ]	N/A	0.108 [80]	N/A				N/A
	Fibers [\$ t <sup>-1</sup> ]		N/A		185 (assumed)		N/A	
Consumables	High-value algae [\$ kg <sup>-1</sup> ]			N/A			45 [84]	
	Flocculant agent [\$ kg <sup>-1</sup> ]			N/A			5 [88]	
	Nutrient BBM [\$ kg <sup>-1</sup> ]			N/A			0.5 [77]	
Utilities	Nutrient H <sub>2</sub> SO <sub>4</sub> [\$ L <sup>-1</sup> ]			N/A			3.1 [89]	
	Electricity [\$ kWh <sup>-1</sup> ]	N/A	0.13 [81]		N/A		0.13 [81]	
	Cold water [\$ m <sup>-3</sup> ]				3.0 [82]			
Fixed operating cost	LPS [\$ t <sup>-1</sup> ]	N/A		13 [85]			N/A	
	Number of shifts X Operators per shift			3 X 8			3 X 20	
	Average salary				15600 \$ annually			
Fixed operating cost	Supervision [% of operating labor]				5%			
	Direct overhead [% of Labor and Supervision]				5%			

Economic assumption	Maintenance [of ISBL investment]	2%	3%	2%
	Land rental [% of ISBL and OSBL]	N/A		
	Property tax [% of ISBL and OSBL]	0.9%		
	Plant overhead [% of Labor and Maintenance]	10%		
	Insurance [% of ISBL and OSBL]	0.5%		
	Cost of capital	5%		
	Tax rate	19%		
	Depreciation method	Straight-line		
	Depreciation period	15 years		
	Lifetime	15 years		

Table 9. Economic model set-up

## 6 RESULTS

### 6.1 Conventional Biogas Plant

In the Appendix A4 is shown PFD of conventional BP and in Figure 27 is block diagram.

There are 2 inputs, wheat straw and water. And there are 5 outputs, residuals, hot water (heat), electricity, air, and exhaust to atmosphere.

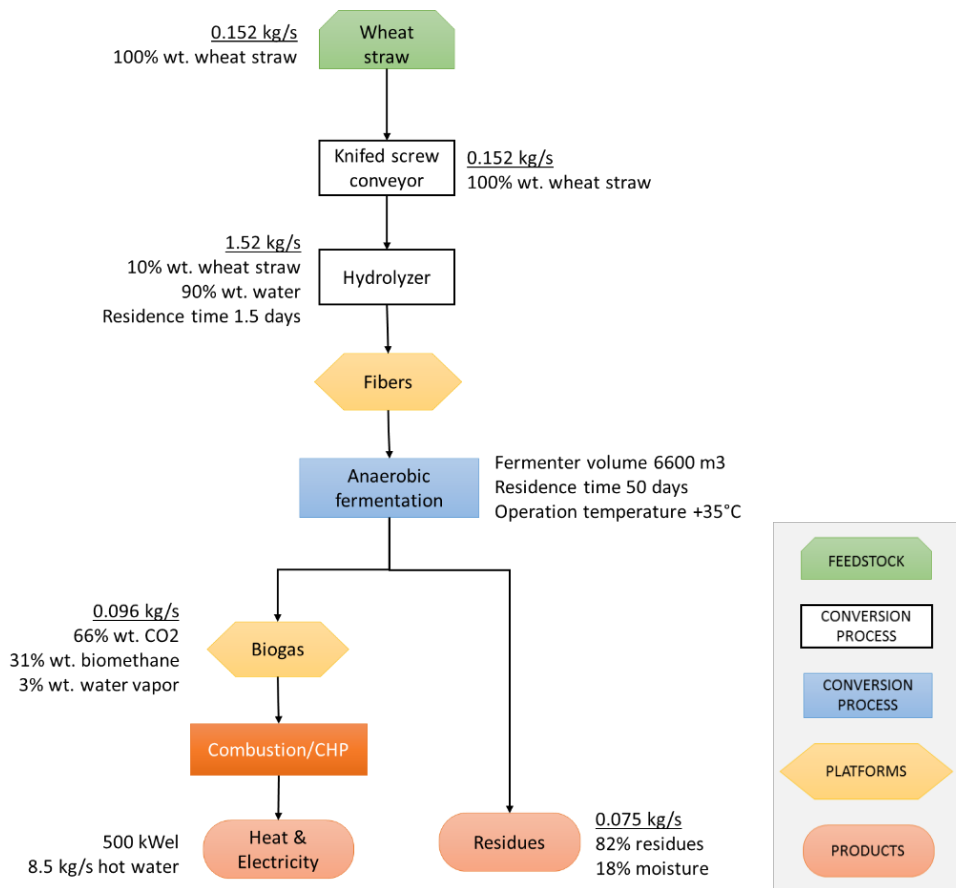

Figure 27. Block diagram, conventional BP

In accordance with Appendix A4, the collection of wheat straw occurs in the storage tanks of agricultural farms, with the storage tank B-100 being specifically designated for this purpose. The collected wheat straw is then transported to the homogenization vessel M-104 via screw conveyor J-101.

Fresh water is supplied to the homogenization vessel M-104 by means of a centrifugal pump P-103, and the concentration of water to wheat straw in the vessel is maintained at 90% wt. and 10% wt. of substrate, respectively, as per reference [69]. The mesophilic conditions are regulated through stream 7, which is derived from the separated residuals of fermentation. This stream is preheated to 40°C in E-113, utilizing hot water from the cogeneration unit. The homogenization vessel M-104 serves as a hydrolyzer and contributes to the softening of

the wheat straw, facilitating biodegradation. Homogenization of the suspension is achieved using a mixer powered by an electric motor.

M-104 is equipped with a vent for vapor removal, which is facilitated by fan G-401. Prior to being discharged into the atmosphere, the media passes through a carbon filter F-400 to eliminate any unpleasant odors.

The homogenized suspension, stream 3, is transported to the fermenter M-106 through screw pump P-105. The residence time of the substrate in the fermenter is 50 days, during which the highest biogas yield is obtained. The suspension in the fermenter is periodically mixed by a mixer, and the volume of the fermenter is  $6600 \text{ m}^3$ , with an OLR of  $2 \text{ kg}_{\text{VS}} \text{ m}^{-3} \text{ d}^{-1}$ . The biogas and methane yields are presented in Table 8.

The fermenter is insulated and preheated to maintain a constant temperature, which is critical for mesophilic organisms. The heat loss for the fermenter is estimated at  $12.5 \text{ W m}^{-3}$ , as per reference [49]. The closed loop consists of vessel B-305, heat exchanger E-303, and centrifugal pump P-304. Stream 22 is heated by water, stream 17, which is sourced from the CHP unit. Although closed loops typically include an expansion vessel, the temperature difference and volume of water are not significant, and volume increase is therefore disregarded.

One ton of wheat straw can produce  $509 \text{ m}^3$  of biogas, of which  $243 \text{ m}^3$  is methane. The produced biogas, stream 8, is purified in H-201 through the condensation of water vapor that is present in the biogas. The water vapor concentration in the biogas prior to condensation is 5% vol.

Cogeneration unit, Q-202, has nominal electric power  $500 \text{ kW}_{\text{el}}$ . During commissioning and start-up, flare FL-203 is used for biogas combustion. When buffer tank B-201 has collected enough biogas to start continuous combustion, stream to flare is closing and valve to CHP unit is opening. Pressure transmitter on B-201 regulates the flow, so that when too much biogas is produced, surplus is burned in flare. Or when flow of biogas is lower than allowable for safe operation of CHP unit the valve downstream B-201 is closed and biogas is fully burned in flare until biogas will reach operation pressure.

Jacket design of cogeneration unit Q-202 warms up the water to  $70 \pm 5 \text{ }^\circ\text{C}$ , stream 20, for the needs of plant operation. Cooled exhausts are discharged to the atmosphere directly.

Screw pump P-107 transfers residuals of anaerobic digestion, stream. Centrifuge decanter X-108 is used to separate liquid and solid phases. This separation process is continuous, and solid phase, stream 5, is moved by screw conveyor J-109 to the storage vessel B-110 or it can be simply stored in open space. Naturally dried residuals are good fertilizers for new agriculture plants.

Separated liquid phase, stream 6, still has organics which were dissolved in water. Preheated up to 40°C, stream 7 is transferred to homogenization vessel, M-104, by centrifugal pump P-112. Separated water reuse delivers savings of fresh water and operation cost.

In Figure 28 is shown simplified scheme which is used for mass balance.

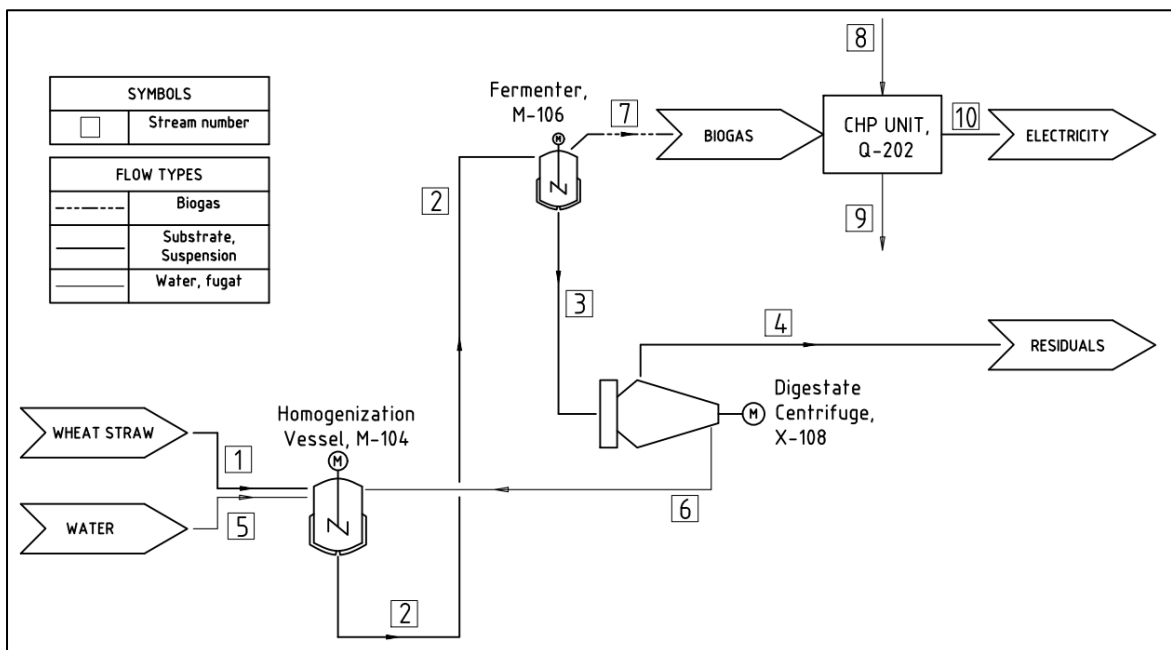

Figure 28. Scheme for mass balance, conventional plant

In Table 10 are shown corresponding mass flow values with the other critical parameters.

Stream number <i>m x;y, x = stream number</i> <i>y = 1 (substrate)</i> <i>2 (water)</i> <i>3 (biogas)</i>	Mass flow [kg s <sup>-1</sup> ]	Note:
m 1;1	0.152	<i>Wheat straw, feedstock</i>
m 2;1	0.152	
m 2;2	1.368	
m 3;1	0.061	
m 3;2	1.363	
m 4;1	0.061	<i>Residuals, solid</i>
m 4;2	0.014	<i>Residuals, water</i>
m 5;2	0.018	
m 6;2	1.350	
m 7;2	0.005	<i>Water vapors</i>
m 7;3	0.091	<i>Biogas</i>
m 8;2	8.500	
m 9;2	8.500	<u>Hot Water</u> <i>3.5 kg/s used for plant operation</i> <i>5.0 kg/s used for agriculture needs</i>
m 10	-	<u>Electricity</u> <i>500 kW installed CHP power,</i> <i>42 kW used for plant operation</i>

*Table 10. Conventional Biogas Plant, mass balance*

Calculation of mass and energy balance can be found in Appendix A1 and A2.

Purchased equipment cost was calculated based on Eq. (57) and for not standard equipment based on specific parameters found during literature search. For more information see Appendix A5.

Name	Tag No.	Key parameter	a	b	n	key parameter	capital cost [\$]
Flare	FL-203	-	[49]			-	10,130
Water Preheater	E-303	m <sup>2</sup>	1600	210	0.95	3	2,196
Water Preheater	E-113	m <sup>2</sup>	1600	210	0.95	3	2,196
Storage Tank	B-100	m <sup>3</sup>	250 \$/m <sup>3</sup> [80]			300(concrete)	75,000
Water Vessel	B-102	kg	11600	34	0.85	1600	29,588
Preheating Water Vessel	B-305	kg	11600	34	0.85	950	23,149
Separated Water Vessel	B-111	kg	11600	34	0.85	950	23,149
Cooled Water Vessel	B-306	kg	11600	34	0.85	1250	26,183
Residual Storage Tank	B-110	m <sup>3</sup>	250 \$/m <sup>3</sup> [80]			500(concrete)	125,000
Biogas Buffer Tank	B-201	kg	11600	34	0.85	1250	26,183
Water Distributor	B-300	kg	11600	34	0.85	200	14,672
Fan	G-401	m <sup>3</sup> .h <sup>-1</sup>	4450	57	0.8	200	8,401
Biogas Blower	G-200	m <sup>3</sup> .h <sup>-1</sup>	4450	57	0.8	490	9,915
Digestate Centrifuge	X-108	diameter, m	CAPCOST [78]			1	43,500
Biofilter	F-400	area, m <sup>2</sup>	CAPCOST [78]			1	25,700
Biogas Purification	H-201	kg	11600	34	0.85	700	20,509
Shredded screw Conveyor	J-101	area, m <sup>2</sup>	CAPCOST [78]			5	10,500
Digestate Screw Conveyor	J-109	area, m <sup>2</sup>	CAPCOST [78]			5	10,500
Homogenization vessel	M-104	m <sup>3</sup>	350 \$/m <sup>3</sup> [80]			20 (concrete)	7,000
Fermenter	M-106	m <sup>3</sup>	125 \$/m <sup>3</sup> [80]			6600 (concrete)	825,000
Supply Water Pump	P-103	1 s <sup>-1</sup>	8000	240	0.9	0.1	8,030
Fermenter Preheating Water Pump	P-304	1 s <sup>-1</sup>	8000	240	0.9	3.2	8,684
Hot Water Pump	P-301	1 s <sup>-1</sup>	8000	240	0.9	1.5	8,346
Hot Water Pump	P-302	1 s <sup>-1</sup>	8000	240	0.9	3.5	8,741
Return Water Pump	P-112	1 s <sup>-1</sup>	8000	240	0.9	3.7	8,779

Slurry Pump	P-105	power, kW	CAPCOST [78]	5	5,960	
Digestate Slurry Pump	P-107	power, kW	CAPCOST [78]	5	5,960	
Cogeneration unit	Q-202	kW	700 [80]	\$/kW	500	350,000
Inside Battery Limit (ISBL) [mil. \$]					1.723	
Offsite Cost (OSBL), 40% of ISBL [mil. \$]					0.689	
Engineering Cost, 20% of ISBL+OSBL [mil. \$]					0.482	
Contingency charges, 10% of ISBL +OSBL [mil. \$]					0.241	
<b>TOTAL FIXED CAPITAL COST [mil. \$]</b>					<b>3.136</b>	
Working Capital [mil. \$]					0.362	

Table 11. Capital Cost, conventional biogas plant

Since it is assumed that biogas plant is part of agriculture farm, hence raw material shall be supplied for free, wheat straw price is zero. Fermentation residues are not sold, but instead are used on the field as a fertilizer. Selling price of generated electricity was found in the Renewable Energy Sources Act 2017 [79] and for rated capacities up to 20 MW, it is \$ 0.1566 kWh<sup>-1</sup> (€ 0.1305 kWh<sup>-1</sup>).

In Table 12 are the energy consumption values for each equipment which is driven by electric motor. More information can be found in Appendix A1.

Name	Tag No.	Power [kW]
Fan	G-401	0.007
Biogas Blower	G-200	0.039
Digestate Centrifuge	X-108	22.500
Shredded Screw Conveyor	J-101	3.000
Digestate Screw Conveyor	J-109	1.500
Homogenization vessel	M-104	0.500
Fermentation vessel	M-106	0.500
Supply Water Pump	P-103	1.000
Fermenter Preheating Water Pump	P-304	1.500
Hot Water Pump	P-301	1.500
Hot Water Pump	P-302	1.500
Return Water Pump	P-112	1.000
Slurry Pump	P-105	3.500
Digestate Slurry Pump	P-107	3.500
<b>Total Power Consumption [kW]</b>		<b>42</b>

Table 12. Electricity consumption data, conventional BP



Coefficients for estimation of operating costs are shown in Table 9. Critical economic parameters for conventional BP are described in Table 13.

CHP installed electric power	500	kW
Electricity purchase cost	0.157	\$ kWh <sup>-1</sup>
Revenue from electricity purchase excluding electricity used in the plant	0.58	mil. \$ y <sup>-1</sup>
<b>Variable Costs excluding depreciation and interest (VCOP)</b>		
Total by products and wastes	0	mil. \$ y <sup>-1</sup>
Raw material	0	mil. \$ y <sup>-1</sup>
Consumables	0	mil. \$ y <sup>-1</sup>
Utilities	0.9	mil. \$ y <sup>-1</sup>
<b>Fixed Costs excluding depreciation and interest (FCOP)</b>		
Labor	0.41	mil. \$ y <sup>-1</sup>
Maintenance	0.06	mil. \$ y <sup>-1</sup>
Property tax	0.02	mil. \$ y <sup>-1</sup>
Plant Overhead	0.05	mil. \$ y <sup>-1</sup>
Insurance	0.01	mil. \$ y <sup>-1</sup>
Taxable income	-0.07	mil. \$ y <sup>-1</sup>
<b>Discounted payback period</b>	<b>negative</b>	<b>years</b>
NPV at the end of plant lifetime	-3.3	mil. \$
IRR at the end of plant lifetime	-15.4	%

Table 13. Cost of Production and Economic Analysis, conventional biogas plant.

## 6.2 Biogas upgrade

In the Appendix B5 is shown PFD of biogas upgrade and in Figure 29 is block diagram.

There are 3 inputs, wheat straw, water and LPS. And there are 5 outputs, biomethane, offgasses, residuals, LPC and air discharged to atmosphere.

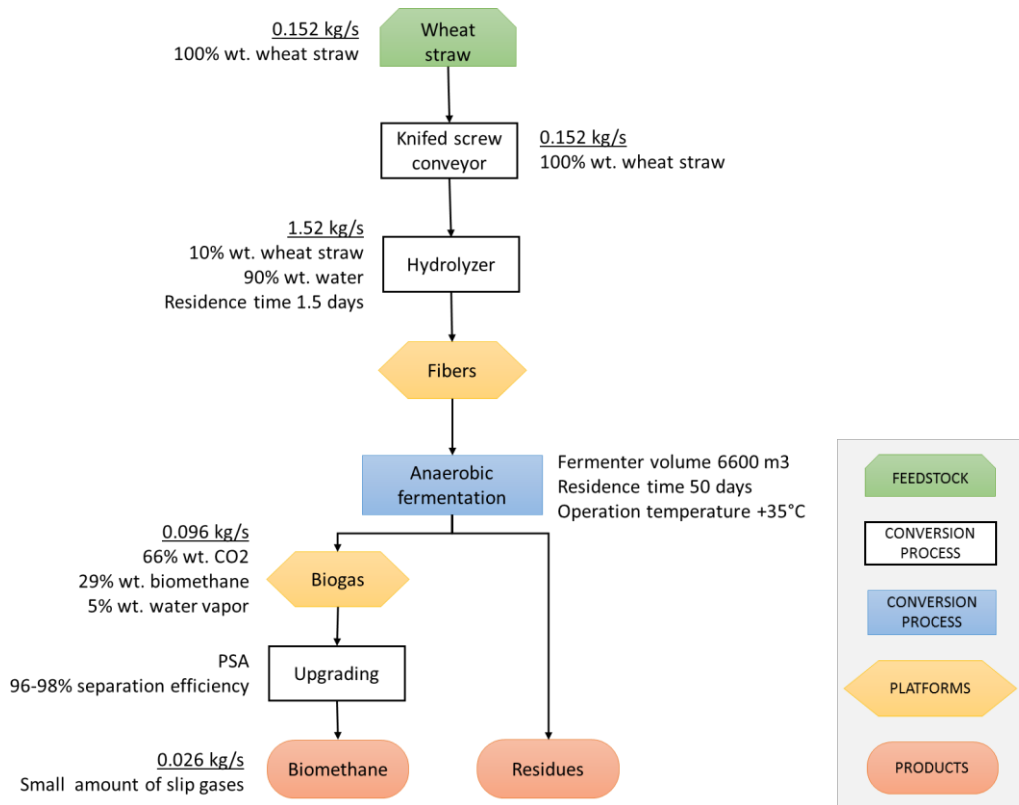

Figure 29. Block diagram, Biogas upgrade

The distinction between a biogas upgrade plant and a conventional plant lies in the use of a biogas separation unit instead of a cogeneration unit. It was decided to utilize pressure-swing adsorption as the upgrade method for the biogas.

In reference to Appendix B5, after biogas production (stream 8), the biogas passes through the condensation equipment H-201. H-201 may be implemented as a buried pipe in the ground, where the water vapor is condensed and removed through the pipe drainage arrangement while the biogas passes through. The resulting stream (9) is then compressed in compressor C-101 to a pressure of 7-8 bar, creating the optimal conditions for CO<sub>2</sub> adsorption. However, the biogas is heated after compression, reducing the efficiency of the adsorption process. To ensure continuous operation, pressure-swing adsorption utilizes both an adsorption section and a desorption section. Zeolite 5A is used as the adsorbent for CO<sub>2</sub> separation, and approximately 2-4% vol. of CH<sub>4</sub> may slip through with the offgases (stream

11). The resulting biomethane (stream 10) has a CH<sub>4</sub> concentration of approximately 97% vol. and can then be transported to the end user.

The same heat exchangers (E-113 and E-303) used in the conventional BP are utilized to maintain the operating conditions of M-104 and M-106, respectively. However, the hot stream is now low-pressure steam (LPS), streams 13 and 14, and the low-pressure condensate (LPC) downstream of the heat exchangers is directed to the plant battery limits.

In Figure 30 is shown simplified scheme which is used for mass balance.

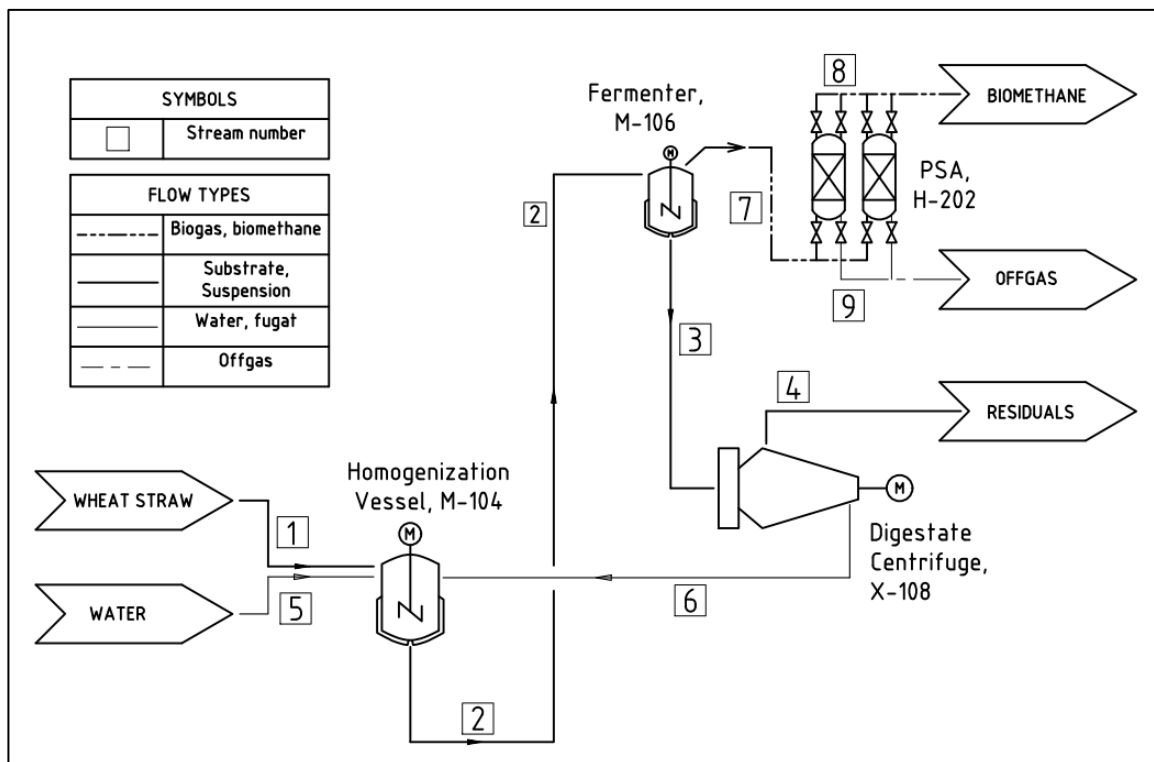

Figure 30. Scheme for mass balance, Biogas upgrade plant

In Table 10 are shown corresponding mass flow values.

Calculation of mass and energy balance can be found in Appendix B1 and B2.

Stream number <i>m x;y, x = stream number</i> <i>y = 1 (substrate)</i> <i>2 (water)</i> <i>3 (CH<sub>4</sub>+CO<sub>2</sub>)</i> <i>4 (methane)</i> <i>5 (carbon dioxide)</i>	Mass flow [kg s <sup>-1</sup> ]	Note:
m 1;1	0.152	<i>Wheat straw, feedstock</i>
m 2;1	0.152	
m 2;2	1.368	
m 3;1	0.061	
m 3;2	1.363	
m 4;1	0.061	<i>Residuals, solid</i>
m 4;2	0.014	<i>Residuals, liquid</i>
m 5;2	0.018	
m 6;2	1.350	
m 7;2	0.005	<i>Water vapors</i>
m 7;3	0.091	<i>Biogas</i>
m 8;4	0.026	<i>CH<sub>4</sub>, biomethane</i>
m 9;2	0.005	<i>Water vapors</i>
m 9;5	0.064	<i>CO<sub>2</sub> + other traces</i>

Table 14. Biogas upgrade Plant, mass balance

Purchased equipment cost was calculated based on Eq. (57) and for not standard equipment based on specific parameters found during literature search. For more information see Appendix B6.

Name	Tag No.	Key parameter	a	b	n	key parameter	capital cost [\$]
Water Preheater	E-303	area, m <sup>2</sup>	1600	210	0.95	3	598
Water Preheater	E-113	area, m <sup>2</sup>	1600	210	0.95	3	598
Storage Tank	B-100	m <sup>3</sup>	250 \$/m <sup>3</sup> [80]			300(concrete)	75,000
Water Vessel	B-102	kg	11600	34	0.85	1600	29,588
Preheating Water Vessel	B-305	kg	11600	34	0.85	950	23,149
Separated Water Vessel	B-111	kg	11600	34	0.85	950	23,149
Condensate Vessel	B-306	kg	11600	34	0.85	1250	26,183
Residual Storage Tank	B-110	m <sup>3</sup>	5800	1600	0.7	1800	309,756
Fan	G-401	m <sup>3</sup> h <sup>-1</sup>	4450	57	0.8	200	8,401
Biogas Blower	G-200	m <sup>3</sup> h <sup>-1</sup>	4450	57	0.8	300	9,915
Digestate Centrifuge	X-108	diameter, m	CAPCOST [78]			1	43,500
Biofilter	F-400	area, m <sup>2</sup>	CAPCOST [78]			1	25,700
Biogas Purification	H-201	kg	10200	31	0.85	700	18,323
Shredded Screw Conveyor	J-101	area, m <sup>2</sup>	CAPCOST [78]			5	10,500
Digestate Screw Conveyor	J-109	area, m <sup>2</sup>	CAPCOST [78]			5	10,500
Homogenization vessel	M-104	m <sup>3</sup>	350 \$/m <sup>3</sup> [80]			20 (concrete)	7,000
Fermenter	M-106	m <sup>3</sup>	125 \$/m <sup>3</sup> [80]			6600 (concrete)	825,000
Supply Water Pump	P-103	l s <sup>-1</sup>	8000	240	0.9	0.2	8,056
Fermenter Preheating Water Pump	P-304	l s <sup>-1</sup>	8000	240	0.9	0.7	8,174
PSA	H-202		Appendix B3 [90], 2 columns				278,956
Return Water Pump	P-112	l s <sup>-1</sup>	8000	240	0.9	1.35	8,314
Slurry Pump	P-105	power, kW	CAPCOST [78]			5	5,960
Digestate Slurry Pump	P-107	power, kW	CAPCOST [78]			5	5,960
Biogas Compressor	C-101	power, kW	CAPCOST [78]			27	19,200

Inside Battery Limit (ISBL) [mil. \$]	1.785
Offsite Cost (OSBL), 40% of ISBL [mil. \$]	0.714
Engineering Cost, 20% of ISBL+OSBL [mil. \$]	0.500
Contingency charges, 10% of ISBL +OSBL [mil. \$]	0.250
<b>TOTAL FIXED CAPITAL COST [mil. \$]</b>	<b>3.248</b>
Working Capital [mil. \$]	0.375

Table 15. Capital Cost, biogas upgrade plant.

In Table 16 are the energy consumption values for each equipment which is driven by electric motor. More information can be found in Appendix B1.

Name	Tag No.	Power [kW]
Fan	G-401	0.007
Biogas Blower	G-200	0.039
Digestate Centrifuge	X-108	22.500
Shredded Screw Conveyor	J-101	3.000
Digestate Screw Conveyor	J-109	1.500
Homogenization vessel	M-104	0.500
Fermentation vessel	M-106	0.500
Supply Water Pump	P-103	1.000
Fermenter Preheating Water Pump	P-304	1.000
Return Water Pump	P-112	1.000
Slurry Pump	P-105	3.500
Digestate Slurry Pump	P-107	3.500
Biogas Compressor	C-101	26.305
<b>Total Power Consumption [kW]</b>		<b>64</b>

Table 16. Electricity consumption data, biogas upgrade

Coefficients for estimation of operating costs are shown in Table 9. Critical economic parameters for biogas upgrade are described in Table 17.

Biomethane production – 8000 working hours annually	748 800	kg y <sup>-1</sup>
Biomethane purchase cost	0.108	\$ kWh <sup>-1</sup>
Revenue from biomethane purchase	1.12	mil. \$ y <sup>-1</sup>
<b>Variable Costs excluding depreciation and interest (VCOP)</b>		
Total by products and wastes	0	mil. \$ y <sup>-1</sup>
Raw material	0	mil. \$ y <sup>-1</sup>
Consumables	0	mil. \$ y <sup>-1</sup>
Utilities	0.20	mil. \$ y <sup>-1</sup>
<b>Fixed Costs excluding depreciation and interest (FCOP)</b>		
Labor	0.41	mil. \$ y <sup>-1</sup>
Maintenance	0.10	mil. \$ y <sup>-1</sup>
Property tax	0.02	mil. \$ y <sup>-1</sup>
Plant Overhead	0.05	mil. \$ y <sup>-1</sup>
Insurance	0.01	mil. \$ y <sup>-1</sup>
Taxable income	0.33	mil. \$ y <sup>-1</sup>
<b>Discounted payback period</b>	<b>17</b>	<b>years</b>
NPV at the end of plant lifetime	-0.2	mil. \$
IRR at the end of plant lifetime	4.3	%

*Table 17 Cost of Production and Economic Analysis, biogas upgrade plant.*

### 6.3 Intensified Biogas Plant

In the Appendices C3, C4 are shown PFDs of intensified BP and in Figure 31 is shown block diagram.

There are 3 inputs, wheat straw, water and LPS. And there are 7 outputs, electricity and warm water, offgasses, residuals, LPC, water to WWTP and air discharged to atmosphere.

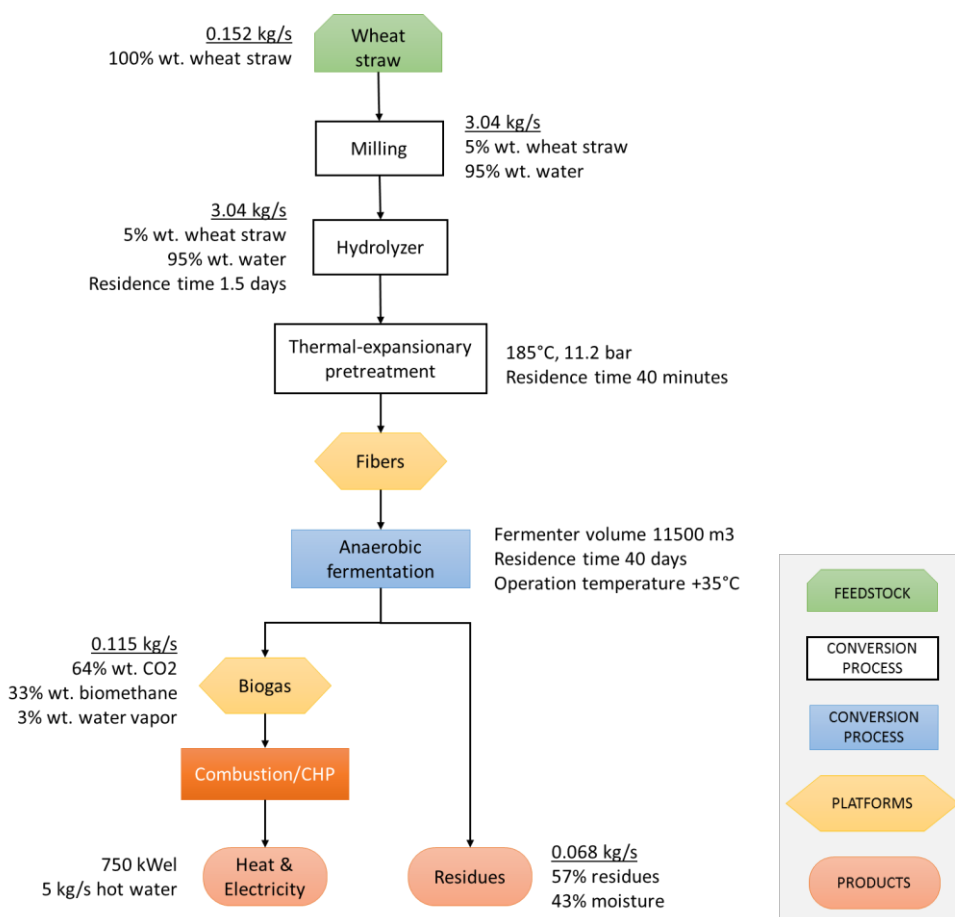

Figure 31. Block diagram, Intensified BP

It is important to note that in comparison to a conventional BP, the mass fraction of solids in the fermenter in this process is only 5%.

With reference to Appendix C3 and C4, the substrate (stream 1) is transported from storage tank B-101 by screw conveyor J-101 and mixed with hot water (stream 31) inside milling machine Z-101. The addition of hot water increases the efficiency of wheat straw disintegration. The suspension is then transferred to the homogenization vessel M-101, where it is held for 1.5 days. The suspension leaving M-101 passes through tubular heat exchanger E-101, where some of the energy is recovered by cooling the suspension leaving the cyclone separator (stream 8). The preheated suspension (stream 5) is then introduced into



the mixed pressure vessel B-102A. The three-way valve upstream of B-102A is logically controlled by a level meter on B-102A and closes when the vessel is full, allowing the stream to fill B-102B. The suspension inside B-102A/B is heated to 185°C and pressurized to 11.2 bars, with a retention time of 40 minutes during which the fibers of the wheat straw deeply absorb water. After 40 minutes, the control valve downstream of B-102A/B opens and the suspension flows through heat exchanger E-102, where it is cooled to approximately 125°C by water used to maintain the operating temperature inside B-102A/B. The control valve downstream of E-102 regulates the flow and prevents early expansion of the stream. The cooled suspension (stream 7) is then expanded in the cyclone MV-100, where the absorbed water immediately evaporates due to the pressure difference. The fibers of the substrate disrupt to the level shown in Figure 34 (page 95) due to the evaporation of the water absorbed by the substrate, and the treated substrate is now ready for further processing. The control valve upstream of MV-100 regulates the constant pressure at the inlet.

The hot water used to maintain the operating conditions in B-102A/B is 190°C and approximately 15 bars and is heated to this high temperature by passing through heat exchangers E-102, E-103 (economizer), and E-104, where the hot streams are the suspension, the exhausts from the CHP, and the LPS, respectively.

With reference to Appendix C4, the suspension, designated as stream 10, passes through a heat exchanger, E-105, where a portion of heat is recovered and utilized to maintain operating conditions within the fermenter, M-103. Subsequently, the suspension, designated as stream 17, is introduced into another heat exchanger, E-106, where the cold water from the battery limit is preheated prior to entering the CHP unit, Q-202. This heat recovery helps to conserve energy and reduce operation costs. The suspension and vapors from MV-100 are collected in the vessel, B-103, which has a ventilation discharge to the atmosphere. The vapors before entering B-103 are cooled in the heat exchanger, E-107, where the cold water from the battery limit is preheated and used for milling in Z-101. The suspension, designated as stream 20, is introduced into the fermenter, M-103, for biodegradation. The pre-treatment process is intensified, resulting in a residence time in the fermenter of 40 days. The volume of the fermenter is 11500 m<sup>3</sup> and the OLR is 1.25 kg<sub>VS</sub> m<sup>-3</sup> d<sup>-1</sup>. The biogas and methane yields are shown in Table 8. The produced biogas follows the same life cycle as in the conventional BP, but due to a higher biogas yield, approximately 50% more electricity is generated. The biogas is combusted in the CHP unit, Q-202, having a nominal electric power capacity of 750 kW<sub>el</sub>. The residuals of the biodegradation are transported by the screw

pump, P-106, to the centrifuge decanter, X-108, where the solid and liquid phases are separated. The solid phase, designated as stream 25, is naturally dried and used as a fertilizer for cultivation, while the liquid phase, designated as stream 26, is filtered in F-106 and discharged to the WWTP.

In Figure 32 is shown simplified scheme which is used for mass balance.

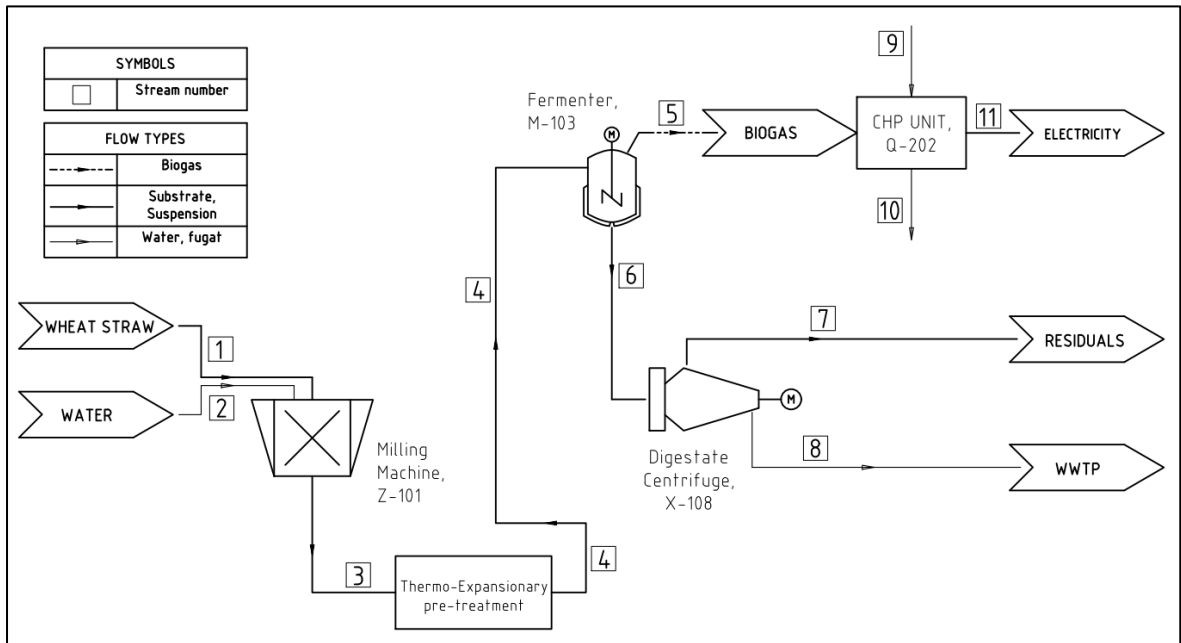

Figure 32. Scheme of mass balance, Intensified Biogas Plant

In Table 18 are shown corresponding mass flow values with the other critical parameters.

Stream number <i>m x;y, x = stream number y = 1 (substrate) 2 (water) 3 (CH<sub>4</sub>+CO<sub>2</sub>)</i>	Mass flow [kg s <sup>-1</sup> ]	Note:
m 1;1	0.152	Wheat straw, feedstock
m 2;2	2.888	Warm water
m 3;1	0.152	
m 3;2	2.888	
m 4;1	0.152	
m 4;2	2.888	
m 5;2	0.003	Water vapor
m 5;3	0.113	Biogas
m 6;1	0.039	
m 6;2	2.885	

m 7;1	0.04	<i>Residuals, solid</i>
m 7;2	0.029	<i>Residuals, liquid</i>
m 8;2	2.856	<i>Separated water residuals</i>
m 9;2	5.000	
m 10;2	5.000	<u>Hot Water</u> 2.9 kg/s used for plant operation 2.1 kg/s used for agriculture needs
m 11	-	<u>Electricity</u> 750 kW installed CHP power, 78 kW used for plant operation

Table 18. Intensified Biogas Plant, mass balance

Calculation of mass and energy balance can be found in Appendix C1.

Purchased equipment cost was calculated based on Eq. (57) and for not standard equipment based on specific parameters found during literature search. For more information see Appendix C5.

Name	Tag No.	Key parameter	a	b	n	key parameter	capital cost [\$]
Flare	FL-203	-	[49]			-	10,130
Suspension Preheater	E-101	m <sup>2</sup>	1900	2500	1	4	11,900
Treatment Preheater	E-102	m <sup>2</sup>	CAPCOST [78]			95	44,200
Economizer	E-103	m <sup>2</sup>	80	2500	1	3	9,400
Treatment Vessel Preheater	E-104	m <sup>2</sup>	1600	210	0.95	11	3,649
Suspension Cooler	E-105	m <sup>2</sup>	1900	2500	1	2	6,900
Suspension Cooler	E-106	m <sup>2</sup>	1900	2500	1	12	31,900
Tap Water Preheater	E-107	m <sup>2</sup>	1900	2500	1	7	19,400
Storage Tank	B-100	m <sup>3</sup>	250 \$/m <sup>3</sup> [80]			300 (concrete)	75,00
Preheating Water Vessel	B-102	kg	11600	34	0.85	590	19,304
Accumulation Vessel	B103	kg	11600	34	0.85	590	19,304

Preheating Water Vessel	B-104	kg	11600	34	0.85	425	17,429
Separated Water Vessel	B-105	kg	11600	34	0.85	950	23,149
Separated Water Filter	F-106	kg	11600	34	0.85	950	31,251
Residual Storage Tank	B-107	m <sup>3</sup>	250 \$/m <sup>3</sup> [80]			500 (concrete)	125,000
Biogas Buffer Tank	B-201	kg	11600	34	0.85	1250	26,183
Biogas Blower	G-200	m <sup>3</sup> h <sup>-1</sup>	4450	57	0.8	400	11,329
Digestate Centrifuge	X-108	diameter, m	CAPCOST [78]			1	56,500
Biofilter	F-100	area, m <sup>2</sup>	CAPCOST [78]			1	25,700
Biogas Purification	H-201	kg	11600	34	0.85	700	20,509
Treated Suspension Separator	MV-100	kg	11600	34	0.85	1800	31,482
Shredded screw Conveyor	J-101	area, m <sup>2</sup>	CAPCOST [78]			5	10,500
Digestate Screw Conveyor	J-102	area, m <sup>2</sup>	CAPCOST [78]			5	10,500
Milling machine	Z-101	diameter, m	[70]			0.5	15,000
Treatment Vessel	B-102A	kg	11600	34	0.85	800	21,579
Treatment Vessel	B-102B	kg	11600	34	0.85	800	21,579
Homogenization vessel	M-101	m <sup>2</sup>	350 \$/m <sup>3</sup> [80]			20 (concrete)	7,000
Fermenter	M-103	m <sup>3</sup>	125 \$/m <sup>3</sup> [80]			11500 (concrete)	1,437,500
Slurry Pump	P-101	power, kW	CAPCOST [78]			5	5,960
Treated Slurry Pump	P-102	power, kW	CAPCOST [78]			5	5,960
Treatment Vessel Preheating Pump	P-103	l s <sup>-1</sup>	8000	240	0.9	3.1	8,664
Treated Slurry Pump	P-104	power, kW	CAPCOST [78]			5	5,960
Treated Slurry Pump	P-105	power, kW	CAPCOST [78]			5	5,960

Digestate Slurry Pump	P-106	power, kW	CAPCOST [78]			5	5,960
Fermenter Preheating Water Pump	P-107	1 s <sup>-1</sup>	8000	240	0.9	1.5	8,346
CHP Water Pump	P-108	1 s <sup>-1</sup>	8000	240	0.9	3	8,645
Separated Water Pump	P-109	1 s <sup>-1</sup>	8000	240	0.9	3.5	8,741
Cogeneration unit	Q-202	kW	700 [80]		\$/kW	750	525,000
Inside Battery Limit (ISBL) [mil. \$]							2.732
Offsite Cost (OSBL), 40% of ISBL [mil. \$]							1.093
Engineering Cost, 20% of ISBL+OSBL [mil. \$]							0.765
Contingency charges, 10% of ISBL +OSBL [mil. \$]							0.383
<b>TOTAL FIXED CAPITAL COST [mil. \$]</b>							<b>4.973</b>
Working Capital [mil. \$]							0.574

Table 19. Capital Cost, intensified biogas plant.

Since it is assumed that biogas plant is part of agriculture farm, hence raw material shall be supplied for free, wheat straw price is zero. Fermentation residues are not sold, but instead are used on the field as a fertilizer.

Selling price of generated electricity was found in the Renewable Energy Sources Act 2017 [79] and for rated capacities up to 20 MW, it is \$ 0.1566 kWh<sup>-1</sup> (€ 0.1305 kWh<sup>-1</sup>). It is estimated that approximately 10% of produced electricity, 78 kW, is used for own needs, mainly for electric motors. In Table 20 are the energy consumption values for each equipment which is driven by electric motor. More information can be found in Appendix C1.

Name	Tag No.	Power [kW]
Biogas Blower	G-200	0.048
Digestate Centrifuge	X-108	41.000
Shredded Screw Conveyor	J-101	3.000
Digestate Screw Conveyor	J-102	1.500
Milling machine	Z-101	7.000
Treatment Vessel	B-102A	0.500
Treatment Vessel	B-102B	0.500
Homogenization vessel	M-101	0.500
Fermenter	M-103	0.500

Slurry Pump	P-101	3.500
Treated Slurry Pump	P-102	3.500
Treatment Vessel Preheating pump	P-103	2.000
Treated Slurry Pump	P-104	3.500
Treated Slurry Pump	P-105	3.500
Digestate Slurry Pump	P-106	3.500
Fermenter Preheating Water Pump	P-107	1.000
CHP Water Pump	P-108	2.000
Separated Water Pump	P-109	1.000
<b>Total Power Consumption [kW]</b>		<b>78</b>

Table 20. Electricity consumption data, intensified BP

Coefficients for estimation of operating costs are shown on Table 9. Critical economic parameters for intensified BP are described in Table 21.

CHP installed electric power	750	kW
Electricity purchase cost	0.157	\$ kWh <sup>-1</sup>
Revenue from electricity purchase excluding electricity used in the plant	0.84	mil. \$ y <sup>-1</sup>
<b>Variable Costs excluding depreciation and interest (VCOP)</b>		
Total by products and wastes	0	mil. \$ y <sup>-1</sup>
Raw material	0	mil. \$ y <sup>-1</sup>
Consumables	0	mil. \$ y <sup>-1</sup>
Utilities	0.32	mil. \$ y <sup>-1</sup>
<b>Fixed Costs excluding depreciation and interest (FCOP)</b>		
Labor	0.46	mil. \$ y <sup>-1</sup>
Maintenance	0.10	mil. \$ y <sup>-1</sup>
Property tax	0.03	mil. \$ y <sup>-1</sup>
Plant Overhead	0.06	mil. \$ y <sup>-1</sup>
Insurance	0.02	mil. \$ y <sup>-1</sup>
Taxable income	-0.15	mil. \$ y <sup>-1</sup>
<b>Discounted payback period</b>	<b>negative</b>	<b>years</b>
NPV at the end of plant lifetime	-5.6	mil. \$
IRR at the end of plant lifetime	-18.1	%

Table 21. Cost of Production, intensified biogas plant.

## 6.4 Biogas-Fiber Biorefinery

In the Appendices D3, D4 are shown PFDs of biogas-fiber biorefinery and in Figure 33 is shown block diagram.

There are 3 inputs, wheat straw, water and LPS. And there are 8 outputs, electricity and warm water, fibers, offgasses, residuals, LPC, water to WWTP and air discharged to atmosphere.

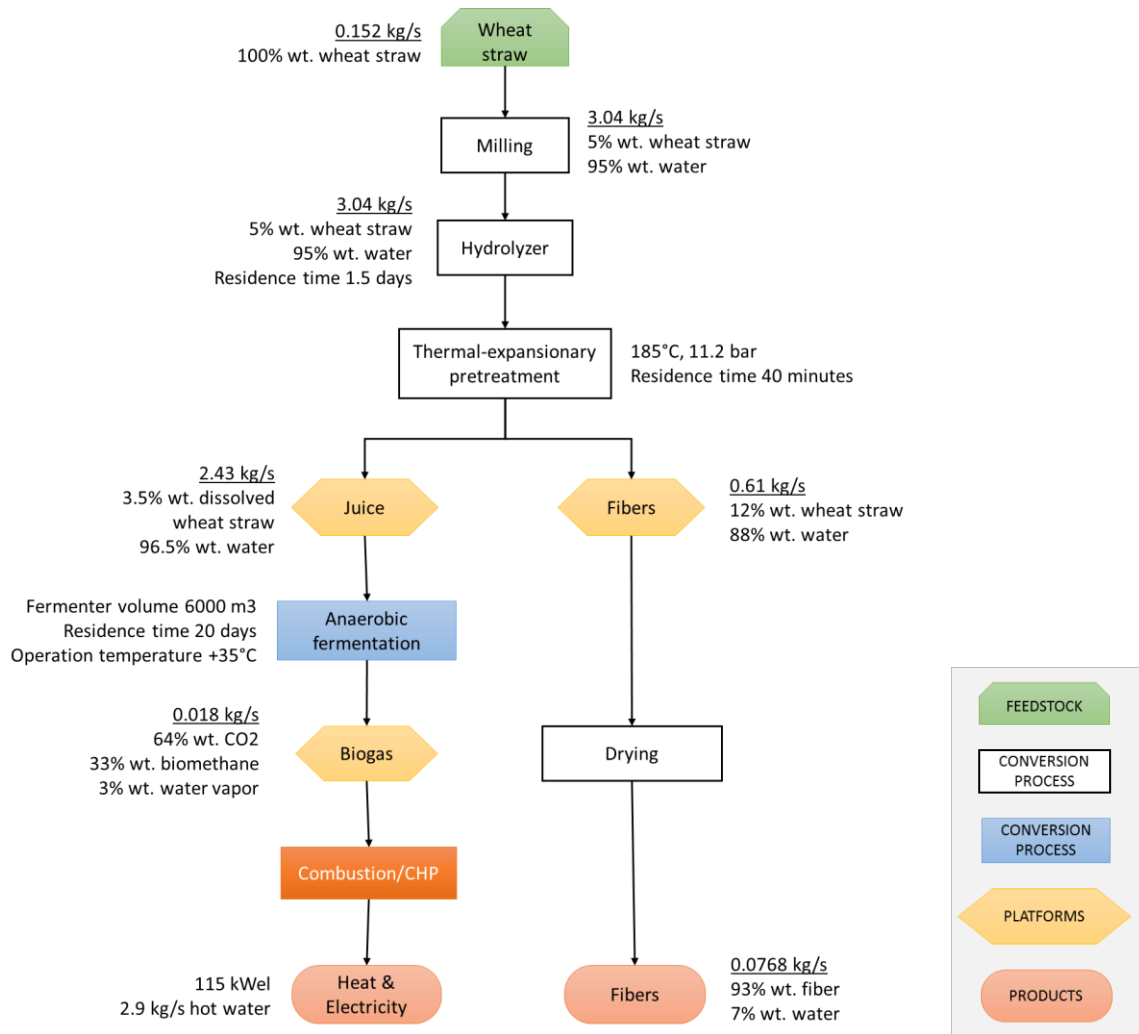

Figure 33. Block diagram, Biogas-Fiber biorefinery

In this concept, an intensified pretreatment process is utilized for feedstock. There are two key differences in comparison to the previous concept. Firstly, the pretreated wheat straw, stream 18, is also cooled in heat exchangers E-105 and E-106, but instead of being directly sent to the fermenter, it is sent to a perforated conveyor belt, MT-300. The 15-meter-long conveyor operates at low speed, allowing for most of the free water not absorbed by the wheat straw to be separated through the perforation. The wet wheat straw is then naturally

dried before being sent to a drum drier, T-300. Figure 34 shows the sample of dried wheat straw after thermal-expansionary pretreatment [69].

The separated liquid contains dissolved organics and unseparated wheat straw. During the pretreatment process, approximately 53% of the wheat straw solid is dissolved in water [69]. The organic-rich water, stream 34, is then sent to the fermenter, M-103. The fermentation residence time is significantly shorter, as there is only a small amount of low-degradable solid particles. Comparing to residence time of 20-24 days of anaerobic fermentation in WWTP [91] it was assumed 20 days for this case. Having less solids, residence time expected to be shorter. The volume of the fermenter is 6000 m<sup>3</sup> and OLR is 2.5 kg<sub>VS</sub> m<sup>-3</sup> d<sup>-1</sup>. The yield was estimated with help of COD test, which is 9.40 g l<sup>-1</sup> for 1 liter of dissolved organic matter in water [48]. According to Eq. (3), it is 3.29 l<sub>CH<sub>4</sub></sub> kg<sup>-1</sup><sub>water</sub>, or 55.95 l<sub>CH<sub>4</sub></sub> kg<sup>-1</sup><sub>wheat\_straw</sub>. Hence, especially for this case it can be produced 55.95 Nm<sup>3</sup> of methane with every ton of dissolved solid matter. From the wastes, in typical pulp industry plant, it is possible to produce maximum 200 Nm<sup>3</sup> t<sup>-1</sup> [92], from livestock manure, organic included, it is possible to produce 40-45 Nm<sup>3</sup> t<sup>-1</sup> [91]. Thus, estimated yield looks quite realistic. Electric power of 110 kW<sub>el</sub> for CHP, was calculated using Eq. (5). The second main difference is that there is no centrifuge decanter for solid separation. Residues, stream 24, are sent to WWTP, stream 26, after passing through fine filters.



*Figure 34. TEP, 185 °C/40min*

In Figure 35 is shown simplified scheme which is used for mass balance.



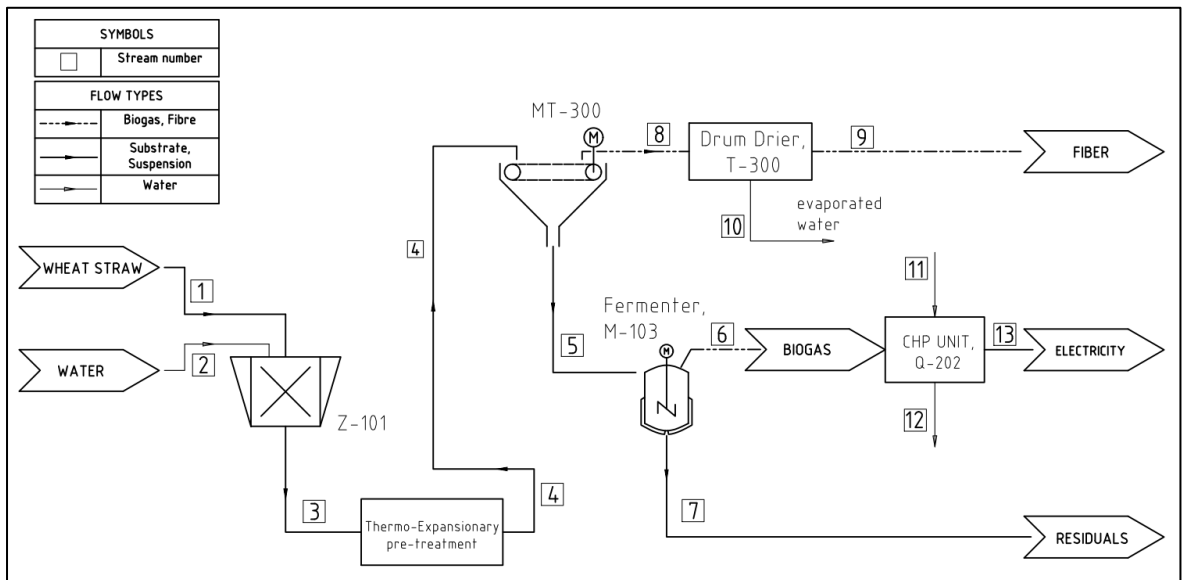

Figure 35. Scheme of mass balance, Biogas-Fiber Biorefinery

In Table 22 are shown corresponding mass flow values and the other critical parameters.

Stream number <i>m x;y, x = stream number y = 1 (substrate) 2 (water) 3 (CH<sub>4</sub>+CO<sub>2</sub>) 4 (fiber)</i>	Mass flow [kg s <sup>-1</sup> ]	Note:
m 1;1	0.1520	Wheat straw, feedstock
m 2;2	2.8880	Warm water
m 3;1	0.1520	
m 3;2	2.8880	
m 4;1	0.1520	
m 4;2	2.8880	
m 5;1	0.0806	
m 5;2	2.3522	
m 6;2	0.0004	Water vapor
m 6;3	0.0178	Biogas
m 7;1	0.0628	Residuals, solid
m 7;2	2.3518	Residuals, liquid
m 8;1	0.0714	
m 8;2	0.5358	
m 9;2	0.0054	
m 9;4	0.0714	Fibers

m 10;2	0.5304	
m 11;2	2.888	
m 12;2	2.888	<u>Hot Water</u> All is used for plant operation
m 13	-	<u>Electricity</u> 115 kW installed CHP power, 90 kW used for plant operation

Table 22. Biogas-Fiber Biorefinery, mass balance

Calculation of mass and energy balance can be found in Appendix D1.

Purchased equipment cost was calculated based on Eq. (57) and for not standard equipment based on specific parameters found during literature search. For more information see Appendix D5.

Name	Tag No.	Key parameter	a	b	n	key parameter	capital cost [\$]
Flare	FL-203	-	[49]			-	10,130
Suspension Preheater	E-101	m <sup>2</sup>	1900	2500	1	2	6,900
Treatment Preheater	E-102	m <sup>2</sup>	CAPCOST [78]			95	44,200
Economizer	E-103	m <sup>2</sup>	1900	2500	1	3	9,400
Treatment Vessel Preheater	E-104	m <sup>2</sup>	1600	210	0.95	16	4,525
Suspension Cooler	E-105	m <sup>2</sup>	1900	2500	1	1	4,400
Suspension Cooler	E-106	m <sup>2</sup>	1900	2500	1	9	24,400
Tap Water Preheater	E-107	m <sup>2</sup>	1900	2500	1	7	19,400
Storage Tank	B-100	kg	5800	1600	0.7	250	82,127
Preheating Water Vessel	B-102	kg	11600	34	0.85	590	19,304
Accumulation Vessel	B103	kg	11600	34	0.85	590	19,304
Preheating Water Vessel	B-104	kg	11600	34	0.85	425	17,429
Separated Water Filter	F-105	kg	11600	34	0.85	950	31,251

Biogas Buffer Tank	B-201	kg	11600	34	0.85	1250	26,183
Biogas Blower	G-200	m <sup>3</sup> h <sup>-1</sup>	4450	57	0.8	400	11,329
Biofilter	F-100	area, m <sup>2</sup>	CAPCOST [78]			1	25,700
Biogas Purification	H-201	kg	11600	34	0.85	700	20,509
Treated Suspension Separator	MV-100	kg	11600	34	0.85	1800	31,482
Shredded screw conveyor	J-101	area, m <sup>2</sup>	CAPCOST [78]			5	10,500
Screw conveyor	J-102	area, m <sup>2</sup>	CAPCOST [78]			5	10,500
Milling machine	Z-101	diameter, m	[70]			0.5	15,000
Treatment Vessel	B-102A	kg	11600	34	0.85	800	21,579
Treatment Vessel	B-102B	kg	11600	34	0.85	800	21,579
Homogenization vessel	M-101	m <sup>2</sup>	350 \$/m <sup>3</sup> [80]			20 (concrete)	7,000
Fermenter	M-103	m <sup>3</sup>	125 \$/m <sup>3</sup> [80]			6000 (concrete)	750,000
Slurry Pump	P-101	power, kW	CAPCOST [78]			5	5,960
Treated Slurry Pump	P-102	power, kW	CAPCOST [78]			5	5,960
Treatment Vessel Preheating Pump	P-103	l.s <sup>-1</sup>	8000	240	0.9	3.1	8,664
Treated Slurry Pump	P-104	power, kW	CAPCOST [78]			5	5,960
Liquid Residuals Pump	P-106	l s <sup>-1</sup>	8000	240	0.9	2.5	8,547
Fermenter Preheating Water Pump	P-107	l s <sup>-1</sup>	8000	240	0.9	1	8,240
CHP Water Pump	P-108	l s <sup>-1</sup>	8000	240	0.9	3	8,645
Perforated Fiber Conveyor	MT-300	length, m	41000	730	1	15	59,743
Fiber Drum Drier	T-300	area, m <sup>2</sup>	CAPCOST [78]			50	438,000
Field for Fiber Natural Drying	MF-300	area, m <sup>2</sup>	16 \$/m <sup>2</sup> [93]			250	4,070

Cogeneration unit	Q-202	kW	700 [80]	\$/kW	115	80,500
Inside Battery Limit (ISBL) [mil. \$]						1.868
Offsite Cost (OSBL), 40% of ISBL [mil. \$]						0.747
Engineering Cost, 20% of ISBL+OSBL [mil. \$]						0.523
Contingency charges, 30% of ISBL +OSBL [mil. \$]						0.785
<b>TOTAL FIXED CAPITAL COST [mil. \$]</b>						<b>3.923</b>
Working Capital [mil. \$]						0.392

Table 23. Capital Cost, biogas-fiber biorefinery

Same as previously, wheat straw is obtained for free from owned farms.

In Table 24 are the energy consumption values for each equipment which is driven by electric motor. More information can be found in Appendix D1. Approximately 80% of produced electricity is used for the plant needs.

Name	Tag No.	Power [kW]
Biogas Blower	G-200	0.048
Shredded Screw Conveyor	J-101	3.000
Milling machine	Z-101	7.000
Treatment Vessel	B-102A	0.500
Treatment Vessel	B-102B	0.500
Homogenization vessel	M-101	0.500
Fermenter	M-103	0.500
Slurry Pump	P-101	3.500
Treated Slurry Pump	P-102	3.500
Treatment Vessel Preheating pump	P-103	2.000
Treated Slurry Pump	P-104	3.500
Liquid Residuals Pump	P-106	1.500
Fermenter Preheating Water Pump	P-107	0.500
CHP Water Pump	P-108	2.000
Perforated Fiber Conveyor	MT-300	1.500
Fiber Drum Drier	T-300	60.000
<b>Total Power Consumption [kW]</b>		<b>90</b>

Table 24. Electricity consumption data, Biogas-Fiber Biorefinery

Coefficients for estimation of operating costs are shown in Table 9. Critical economic parameters for conventional are described in Table 25.

CHP installed electric power	115	kW
Electricity purchase cost	0.157	\$ kWh <sup>-1</sup>
Revenue from electricity purchase excluding electricity used in the plant	0.03	mil. \$ y <sup>-1</sup>
Fiber production – 8000 working hours annually	2 056 320	kg y <sup>-1</sup>
Fiber purchase cost	0.185	\$ kg <sup>-1</sup>
Revenue from fiber purchase	0.38	mil. \$ y <sup>-1</sup>
<b>Variable Costs excluding depreciation and interest (VCOP)</b>		
Total by products and wastes	0	mil. \$ y <sup>-1</sup>
Raw material	0	mil. \$ y <sup>-1</sup>
Consumables	0	mil. \$ y <sup>-1</sup>
Utilities	0.55	mil. \$ y <sup>-1</sup>
<b>Fixed Costs excluding depreciation and interest (FCOP)</b>		
Labor	0.41	mil. \$ y <sup>-1</sup>
Maintenance	0.08	mil. \$ y <sup>-1</sup>
Property tax	0.02	mil. \$ y <sup>-1</sup>
Plant Overhead	0.05	mil. \$ y <sup>-1</sup>
Insurance	0.01	mil. \$ y <sup>-1</sup>
Taxable income	-0.72	mil. \$ y <sup>-1</sup>
<b>Discounted payback period</b>	<b>negative</b>	<b>years</b>
NPV at the end of plant lifetime	-9.3	mil. \$
IRR at the end of plant lifetime	undefined	%

Table 25. Cost of Production and Economic Analysis, biogas-fiber biogas plant

## 6.5 Biogas-Algae Biorefinery

In the Appendices E3, E4 are shown PFDs of biogas-algae biorefinery and in Figure 36 is block diagram.

There are 2 inputs, wheat straw and water, beside nutrients for algae cultivation and flocculation agents for algae harvesting. Also, there are 8 outputs, electricity, high-value algae, heat (in form of warm water), residuals, offgasses, water to WWTP and air discharged to atmosphere.

The wheat straw, designated as stream 1, is conveyed with a screw conveyor, J-101, to the retting mill, Z-101, and mixed with warm water, stream 6, to form a concentration of 60%wt. wheat straw and 40%wt. water, respectively. The added water has a temperature of 60-70°C and is sourced from the combined heat and power (CHP) unit, Q-202. The retting mill employs a combination of crushing and cutting methods to process the wheat straw. The resulting suspension, with a prevailing wheat straw concentration, is then directed to the homogenization vessel, M-101. Here, cold water is mixed with heated water from the CHP unit and pumped to vessel B-102 to achieve a suspension temperature of 35°C. Subsequently, the water is pumped into Homogenization vessel M-101, where all inlet streams are mixed, resulting in a wheat straw concentration of 10%wt. and a suspension temperature of 35-40°C. The residence time in vessel M-101 is 1.5 days. Stream 3 is then sent with a slurry screw pump, P-102, to the fermenter, M-102, where it resides for 50 days. The volume of the fermenter is 7223 m<sup>3</sup>, and the OLR is 2 kg<sub>VS</sub> m<sup>-3</sup> d<sup>-1</sup>. The heat exchanger, E-101, is used to preheat the technical water, which is used to maintain mesophilic conditions in the fermenter. The cold technical water is preheated by the hot water from the CHP unit, and after 50 days of residence time, the fermenter can produce 605 Nm<sup>3</sup> t<sub>TS</sub><sup>-1</sup> of biogas, from which 343 Nm<sup>3</sup> t<sub>TS</sub><sup>-1</sup> is methane. In the purifying unit, H-201, biogas is mainly condensed to remove water residuals. The biogas is combusted in the CHP unit, with installed electric power of 750 kW<sub>el</sub>. However, with 38% electrical efficiency, a maximum of 709 kW<sub>el</sub> is produced, which is calculated with the help of Eq. (5).

The digestate is separated using a centrifuge decanter, X-102. Stream 5 is utilized as a fertilizer within the farm, while the separated liquid, stream 16, is directed to the WWTP. Stream 16 is not recirculated back to the fermenter to avoid any adverse impact on the digestion process. Preheated water from the CHP unit, with an outlet temperature of 60-70°C, is utilized for the plant's needs at a flow rate of 2.235 kg s<sup>-1</sup>, while the remaining water, stream 15, with a flow rate of 2.8 kg s<sup>-1</sup>, is used as hot tap water on the farm. Tail gas is

cooled down in the multiple-pipe heat exchanger, E-301, to room temperature and then utilized as feed for algae cultivation. The heated water, stream 27, from the E-301, with an outlet temperature of 60-70°C and a mass flow rate of 0.55 kg s<sup>-1</sup>, is additionally utilized as hot tap water on the farm. The absence of any negative impact on algae cultivation due to tail gases has been discussed previously. Cooled exhaust gases, stream 25, are employed for *Chlorella vulgaris* cultivation in a co-annular photobioreactor (PBR), as shown in Figure 19. The space between the two cylinders is filled with potable water, with a working volume of 258 L. A mixture of air and carbon dioxide (9% vol.) is supplied from the bottom of the co-annular PBR [76]. Additionally, 0.705 g L<sup>-1</sup> of BBM and 1 mL of 0.1% Sulfuric acid are added once every three days. Based on the accumulated tail gases, stream 10, it is estimated that 8890 co-annular PBRs could be installed. The residence time for *Chlorella vulgaris* cultivation is 10 days. The building, where PBRs are installed, is made from a steel structure and transparent cladding, which allows natural light penetration. Transparent cladding is used to reduce electricity costs associated with lighting bulbs used for algae cultivation.

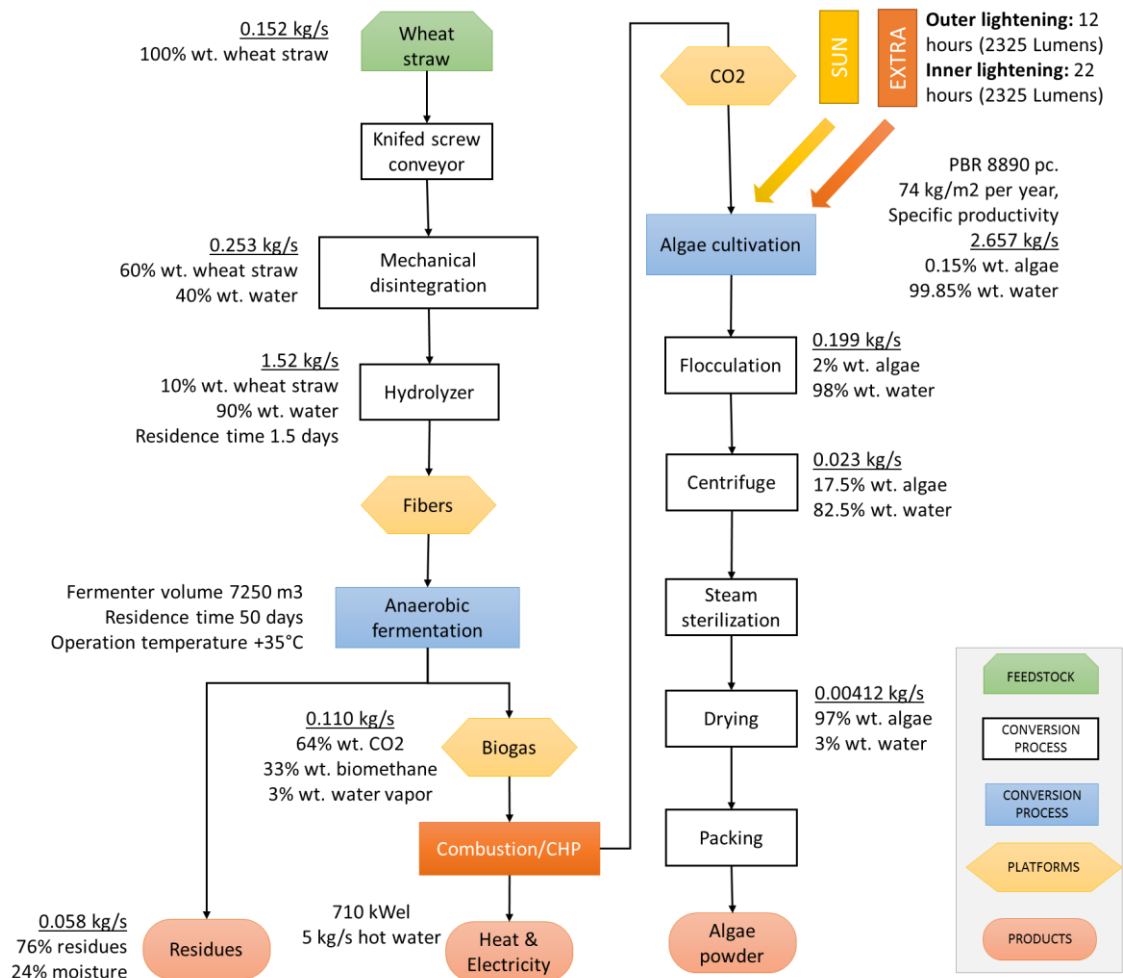

Figure 36. Block diagram, Biogas-Algae Biorefinery

The algae productivity for autotrophic and mixotrophic growth is  $0.15 \text{ g L}^{-1} \text{ day}^{-1}$ . The annual algae production for the designed farm is estimated to be 107.46 tons of biomass, which corresponds to approximately 5.4% of the worldwide production [73]. Following cultivation, the algae biomass is harvested by withdrawing the cultivated mixture into the tank, F-301, and flocculating it with *Strychnos potatorum* [88]. The bio-flocculant used in the process shows promise as a substitute for expensive and hazardous chemical flocculants. The mixture after flocculation has a total solids content of 2% [94], which is then sent to the high-speed centrifuge, X-301, where the total solids content increases to 17% [95] [96]. Finally, the mixture is dried in drum T-301 [97], and after drying, the total solids content rises to 97% [98].

In Figure 37 is shown scheme which is used for mass balance.

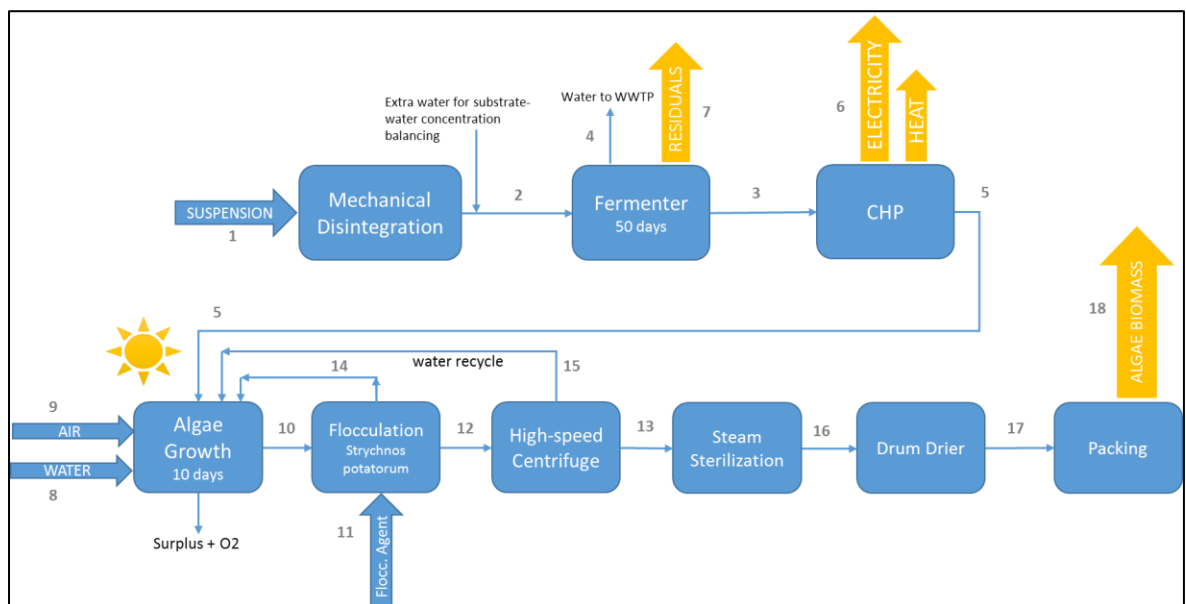

Figure 37. Scheme of mass balance, Biogas-Algae Biorefinery

In Table 26 are shown corresponding mass flow values and the other critical parameters.



Stream number <i>m x;y, x = stream number</i> <i>y = 1 (suspension)</i> 2 (water) 3 (CH <sub>4</sub> +CO <sub>2</sub> ) 4 (exhausts) 5 (algae biomass) 6 (floculant agent) 7 (air)	Mass flow [kg s <sup>-1</sup> ]	Note:
m 1;1	0.152	Wheat straw
m 1;2	0.101	Hot water
m 2;1	0.152	Wheat straw
m 2;2	1.368	Warm water
m 3;3	0.108	Biogas
m 4;2	1.352	Residuals, liquid
m 5;4	1.433	Flue gases
m 6	-	<u>Electricity</u> 750 kW installed CHP power, 79 kW used for plant operation + extra for lightening
	7.3	<u>Heat (hot water)</u> 2.3 kg/s used for plant operation 5.0 kg/s used for agriculture needs
m 7;-	0.058	Residuals, solids
m 8;2	2.653	Water for algae cultivation
m 9;7	5.055	Air for algae cultivation
m 10;2	2.653	
m 10;5	0.0040	
m 11;6	0.0003	Floculant agent
m 12;2	0.195	
m 12;5	0.0040	
m 13;2	0.019	
m 13;5	0.0040	
m 14;2	2.458	Water recycling
m 15;2	0.1756	Water recycling

m 16;2	0.019	
m 16;5	0.0040	
m 17;2	0.00012	
m 17;5	0.0040	
m 18;5	0.00410	<i>High-value algae powder</i>

Table 26. Biogas-Algae Biorefinery, mass balance

Calculation of mass and energy balance can be found in Appendix E1.

Algae unit with PBR arrangement is shown in Appendix E5

Purchased equipment cost was calculated based on Eq. (57) and for not standard equipment based on specific parameters found during literature search. For more information see Appendix E6.

Name	Tag No.	Key parameter	a	b	n	key parameter	capital cost [\$]
Flare	FL-203	-	[49]			-	10,130
Water Preheater	E-101	m <sup>2</sup>	1600	210	0.95	2	2,006
Economizer	E-301	m <sup>2</sup>	28000	54	1.2	6	28,464
Storage Tank	B-101	kg	5800	1600	0.7	250	82,127
Water Vessel	B-102	kg	11600	34	0.85	590	19,304
Preheating Water Vessel	B-103	kg	11600	34	0.85	425	17,429
Water Vessel	B-104	kg	11600	34	0.85	590	19,304
Separated Water Vessel	B-105	kg	11600	34	0.85	425	17,429
Residual Storage Tank	B-106	kg	250 \$/m <sup>3</sup> [80]			500 (concrete)	125,000
Distribution vessel	B-201	kg	11600	34	0.85	590	19,304
Biogas Buffer tank	B-202	kg	11600	34	0.85	1250	26,183
Fan	G-101	m <sup>3</sup> h <sup>-1</sup>	4450	57	0.8	200	8,401
Biogas Blower	G-201	m <sup>3</sup> h <sup>-1</sup>	4450	57	0.8	400	11,329
Exhaust Gas Blower	G-301	m <sup>3</sup> h <sup>-1</sup>	4450	57	0.8	2500	34,251
Digestate Centrifuge	X-102	diameter, m	CAPCOST [78]			1	43,000

Algae Centrifuge	X-301	diameter, m	CAPCOST [78]			1	31,200
Biofilter	F-100	area, m <sup>2</sup>	CAPCOST [78]			1	25,700
Biogas Purification	H-201	kg	11600	34	0.85	700	20,509
Shredded Screw Conveyor	J-101	area, m <sup>2</sup>	CAPCOST [78]			5	10,500
Digestate Screw Conveyor	J-102	area, m <sup>2</sup>	CAPCOST [78]			5	10,500
Milling machine	Z-101	diameter, m	[70]			0.5	15,000
Homogenization vessel	M-101	m <sup>2</sup>	350 \$/m <sup>3</sup> [80]			20 (concrete)	7,000
Fermenter	M-102	m <sup>3</sup>	125 \$/m <sup>3</sup> [80]			7223 (concrete)	902,875
Supply Water Pump	P-101	1 s <sup>-1</sup>	8000	240	0.9	1.5	8,346
Slurry Pump	P-102	power, kW	CAPCOST [78]			5	5,960
Fermenter Preheating Water Pump	P-103	1 s <sup>-1</sup>	8000	240	0.9	1	8,240
Digestate Slurry Pump	P-104	power, kW	CAPCOST [78]			5	5,960
Wastewater Pump	P-105	1 s <sup>-1</sup>	8000	240	0.9	1.5	8,346
Hot Water Pump	P-201	1 s <sup>-1</sup>	8000	240	0.9	1	8,240
Hot Water Pump	P-202	1 s <sup>-1</sup>	8000	240	0.9	1.5	8,346
Algae Pump	P-301	power, kW	CAPCOST [78]			5	5,960
Algae Pump	P-302	power, kW	CAPCOST [78]			5	5,960
Cogeneration unit	Q-202	kW	700 [80]		\$/kW	750	525,000
<b>Algae Cultivation</b>							
Outer PBR Cylinder	-	-	0.538 [99]		\$/L	8890 pc, 500L	2,391,410
Inner PBR Cylinder	-	-	0.885 [99]		\$/L	8890 pc, 178L	1,400,442
Internal Fluorescent Bulb	-	-	2 [100]		\$/pc.	T12, 40W, 8890pc.	17,780

External Fluorescent Bulb, top	-	-	2 [100]			\$/pc.	T12, 40W, 8890pc.	100,460
External Fluorescent Bulb, bottom	-	-	2 [100]			\$/pc.	T12, 40W, 8890pc.	100,460
Basement	-	-	50 [101]			\$/m <sup>2</sup>	14 000 m <sup>2</sup>	700,000
Greenhouse roof	-	-	160 [102]			\$/m <sup>2</sup>	each 2706m <sup>2</sup> , 4.7 pc.	2,034,912
Algae Flocculation	F-301	volume, m <sup>3</sup>	250 \$/m <sup>3</sup> [80]				75 (concrete), scrubber	93,750
Perforated Algae Conveyor	MT-301	length, m	41000	730	1		15	59,743
Algae Drum Drier	T-301	area, m <sup>2</sup>	CAPCOST [78]				20	183,000
Inside Battery Limit (ISBL) [mil. \$]								9.160
Offsite Cost (OSBL), 40% of ISBL [mil. \$]								3.664
Engineering Cost, 20% of ISBL+OSBL [mil. \$]								2.565
Contingency charges, 30% of ISBL +OSBL [mil. \$]								1.282
<b>TOTAL FIXED CAPITAL COST [mil. \$]</b>								<b>16.671</b>
Working Capital [mil. \$]								1.924

Table 27. Capital Cost, biogas-algae biorefinery

Same as previously, wheat straw wastes are harvested for free from owned farms.

The biogas-algae biorefinery assumes that all the electricity produced is sold, and electricity is purchased for electrically driven equipment and other utilities. Consumables such as BBM, sulfuric acid, and *Strychnos potatorum* are required for algae cultivation and flocculation. Preheated water from the CHP unit is utilized either within the plant or distributed within the farm battery limit. Fermentation residuals are used as fertilizers.

The techno-economic analysis for algae cultivation is investigated separately for both autotrophic and mixotrophic microorganisms. The reason for separating the analysis is primarily due to variable operation costs. Autotrophic microorganisms require more light, whereas mixotrophic microorganisms require more frequent consumable dosage during cultivation.

In Table 28 are the energy consumption values for each equipment which is driven by electric motor. More information can be found in Appendix E1.

Name	Tag No.	Power [kW]	Note:
Fan	G-101	0.007	-
Biogas Blower	G-201	0.046	-
Exhaust Gas Blower	G-301	0.336	-
Digestate Centrifuge	X-102	22.500	Decanter Centrifuge
Algae Centrifuge	X-301	5.000	Bowl Centrifuge
Shredded Screw Conveyor	J-101	3.000	-
Digestate Screw Conveyor	J-102	1.500	-
Perforated Algae Conveyor	MT-301	1.500	Perforated Conveyor Belt
Milling machine	Z-101	7.000	-
Homogenization vessel	M-101	0.500	-
Fermenter	M-102	0.500	-
Supply Water Pump	P-101	1.000	Centrifugal Pump
Slurry Pump	P-102	3.500	Screw-type Pump
Fermenter Preheating Water Pump	P-103	1.000	Centrifugal Pump
Digestate Slurry Pump	P-104	3.500	Screw-type Pump
Wastewater Pump	P-105	1.000	Centrifugal Pump
Hot Water Pump	P-201	1.000	Centrifugal Pump
Hot Water Pump	P-202	1.000	Centrifugal Pump
Algae Pump	P-301	3.500	Screw-type Pump
Algae Pump	P-302	3.500	Screw-type Pump
Drum Algae Drier	T-301	18.000	Drum-type Drier
Internal Fluorescent Bulb	T12 bulb	-	Energy consumption calculated as per <b>light:dark</b> ratio.
External Fluorescent Bulb, top	T12 bulb	-	
External Fluorescent Bulb, bottom	T12 bulb	-	
<b>Total Power Consumption [kW]</b>		<b>79</b>	

Table 28. Electricity consumption data, Biogas-Algae Biorefinery

### 6.5.1 Biogas-algae, autotrophic growth

To presume autotrophic growth the light:dark ratio for internal bulbs and externals bulbs is 22:2 and 15:7, respectively, see to Figure 19. The dry algae productivity is  $0.15 \text{ g L}^{-1}\text{day}^{-1}$ . Annually, each PBR can produce 12.1 kg of algae biomass. Annual specific algae productivity per occupied farm area is  $7.7 \text{ kg m}^{-2}$  and that only for the PBR-occupied area alone is  $26.9 \text{ kg m}^{-2}$ .

For autotrophic growth, BBM nutrients are added to the PBR every 3 days [76].

Algae farms occupies relatively huge area, thus more people should work on site.

See Appendix E6 for more information.

CHP installed electric power	750	kW
Electricity purchase cost	0.157	\$ kWh <sup>-1</sup>
Revenue from electricity purchase	0.83	mil. \$ y <sup>-1</sup>
Algae production – 7500 working hours annually	107 451	kg y <sup>-1</sup>
Algae purchase cost	45	\$ kg <sup>-1</sup>
Revenue from fiber purchase	4.84	mil. \$ y <sup>-1</sup>
<b>Variable Costs excluding depreciation and interest (VCOP)</b>		
Total by products and wastes	0	mil. \$ y <sup>-1</sup>
Raw material	0	mil. \$ y <sup>-1</sup>
Consumables	0.87	mil. \$ y <sup>-1</sup>
Utilities	3.87	mil. \$ y <sup>-1</sup>
<b>Fixed Costs excluding depreciation and interest (FCOP)</b>		
Labor	1.04	mil. \$ y <sup>-1</sup>
Maintenance	0.33	mil. \$ y <sup>-1</sup>
Property tax	0.12	mil. \$ y <sup>-1</sup>
Plant Overhead	0.14	mil. \$ y <sup>-1</sup>
Insurance	0.06	mil. \$ y <sup>-1</sup>
Taxable income	-0.75	mil. \$ y <sup>-1</sup>
<b>Discounted payback period</b>	<b>negative</b>	<b>years</b>
NPV at the end of plant lifetime	-21.4	mil. \$
IRR at the end of plant lifetime	undefined	%

Table 29. Cost of Production and Economic Analysis, biogas-algae (autotrophic growth)

### 6.5.2 Biogas-algae, mixotrophic growth

Mixotrophic growth technique includes autotrophic and heterotrophic growth. Thus, algae shall receive less light. Light:dark ratio for internal and external bulbs is 12:12. The dry algae productivity is same as during autotrophic growth 0.15 g L<sup>-1</sup>day<sup>-1</sup>. Since less light is used

for mixotrophic growth, it is assumed that nutrients should be added every 2 days. Dosing amount per one time is same. See Appendix E7 for more information.

CHP installed electric power	750	kW
Electricity purchase cost	0.157	\$ kWh <sup>-1</sup>
Revenue from electricity purchase	0.83	mil. \$ y <sup>-1</sup>
Algae production – 7500 working hours annually	107 451	kg y <sup>-1</sup>
Algae purchase cost	45	\$ kg <sup>-1</sup>
Revenue from algae purchase	4.84	mil. \$ y <sup>-1</sup>
<b>Variable Costs excluding depreciation and interest (VCOP)</b>		
Total by products and wastes	0	mil. \$ y <sup>-1</sup>
Raw material	0	mil. \$ y <sup>-1</sup>
Consumables	1.28	mil. \$ y <sup>-1</sup>
Utilities	3.2	mil. \$ y <sup>-1</sup>
<b>Fixed Costs excluding depreciation and interest (FCOP)</b>		
Labor	1.04	mil. \$ y <sup>-1</sup>
Maintenance	0.33	mil. \$ y <sup>-1</sup>
Property tax	0.12	mil. \$ y <sup>-1</sup>
Plant Overhead	0.14	mil. \$ y <sup>-1</sup>
Insurance	0.06	mil. \$ y <sup>-1</sup>
Taxable income	-0.52	mil. \$ y <sup>-1</sup>
<b>Discounted payback period</b>	<b>negative</b>	<b>years</b>
NPV at the end of plant lifetime	-19.5	mil. \$
IRR at the end of plant lifetime	undefined	%

Table 30. Cost of Production and Economic Analysis, biogas-algae (mixotrophic growth)

## 7 DISCUSSION

This dissertation is based on three published articles and five conference proceedings [AK1] [AK2] [AK3] [AK4] [AK6] [AK8] [AK9] [AK10]. However, it should be noted that the economic analysis results presented in this thesis differ from those in the articles. This is primarily due to the following assumptions and considerations:

- Raw material price is assumed to be zero, as the biogas plant is a part of an agriculture farm.
- Fermentation residuals are utilized as fertilizers in agriculture and are not sold.
- For some pressure and non-pressure vessels, the purchased cost was recalculated.
- Updated utility prices were considered.
- Discounted payback period was used instead of simple payback.

After estimating the conventional BP, the results were compared with those found during the literature search. For example, Plant B constructed by Balussou et al. [80] has a payback period of 6.7 years with a CHP of 500 kW<sub>el</sub>, processing 95% maize silage and 5% wheat. In Plant B [80], the OLR is 3.5 kg<sub>vs</sub> m<sup>-3</sup> d<sup>-1</sup>, compared to 2 kg<sub>vs</sub> m<sup>-3</sup> d<sup>-1</sup> in this thesis. The total capital investment for Plant B is 2 million euros, compared to 3.1 million dollars in this thesis. Variable and fixed costs are 0.8 million euros, compared to 0.51 million dollars in this thesis. Total revenues are 0.9 million euros, compared to 0.58 million dollars in this thesis. Plant B [80] receives different kinds of subsidies such as feed-in tariff for electricity into the grid, energy crops bonus, technology bonus, etc. Another payback period of 8 years [103] for a quite similar subsidized conventional biogas plant was reported, which produces 500 kW<sub>el</sub> in CHP unit with fermenter volume 3000 m<sup>3</sup> and feedstocks maize silage, wheat, and cattle manure. In this thesis, the estimated negative payback period of the conventional BP reflects the necessity of subsidies.

The biogas upgrade concept involves a biogas production process that is similar to conventional BP. The produced biogas is then upgraded to biomethane. A study of Plant C [80], which was based on the biogas upgrade concept, found that it had a payback period of 9.7 years, processing 88% maize silage and 12% wheat silage. The plant had a biomethane production rate of 500 Nm<sup>3</sup> h<sup>-1</sup>, compared to the rate of 133 Nm<sup>3</sup> h<sup>-1</sup> produced in this thesis. The thesis also found that subsidies for avoided network fees and sales of fertilizers were received at Plant C [80]. Additionally, factors such as a smaller fermenter and higher organic loading rate led to smaller capital investments. The payback period calculated in this thesis,



17 years, is considered reasonable given the larger fermenter and lower biomethane production rate. Of all the concepts studied, biogas upgrade is the only one with a positive payback period. To improve the payback period, it is recommended to implement mechanical pretreatment of wheat straw to increase the yield of biogas and biomethane. This can be achieved using mechanical pretreatment similar to that used in biogas-algae biorefineries, which has the potential to increase biomethane yield by 40% vol.

The results of an intensified biogas plant study showed higher biogas yield, but also revealed more disadvantages than advantages. It can be concluded that a biogas plant with additional raw material pre-treatment, beyond mechanical disintegration, is not economically feasible. In other words, it was found that the expenses required to increase biogas yield by just 5% compared to using mechanical disintegration alone [70] are too high for the intensified biogas plant concept. Additionally, the OLR is lower compared to conventional plants with mechanical pretreatment, which increases the capital cost of the fermenter. The operating pressure for the equipment during the treatment process is higher than in a conventional plant, leading to higher safety risks for workers. The thermal- expansionary pretreatment showed a higher biogas yield, but further research is needed to decrease capital costs and improve variable costs.

The biogas-fiber biorefinery concept involves an intensified pretreatment process for improved lignocellulosic cell disruption. The production of fiber has the potential to be a promising technology due to its diverse applications, such as a natural insulation material or combined production with polymers. However, the results of the study indicated that the price of fiber must be higher than 500 \$ per ton for the project to be economically viable.

The biogas-algae biorefinery concept involves the use of mechanical disintegration only, as compared to the intensified biogas plant. Most of the existing techno-economic analyses of algae cultivation have focused on biofuel production [104] [105] [106]. However, the cultivation of algae for biofuel purposes is not economically feasible. It has been reported that to compete with petroleum at a price of 100 \$ per barrel, biomass with 40% oil content would need to be produced at a price of 0.16 \$ per kg [74]. For example, the production cost of algae biomass for biodiesel ranges between 2.17 and 9.92 \$ per liter, depending on the cultivation method [107]. Currently, mixotrophic and heterotrophic techniques are used for cultivation because the variable costs are lower compared to autotrophic growth conditions. The estimated oil production cost for heterotrophic cultivation of *Chlorella zofingiensis* is 0.9 \$ per liter [108], which is still five times more expensive than the comparable method

[109]. Algal-based biorefineries have been developed [110] that produce astaxanthin, b-carotene, and fertilizers. Based on different scenarios of biomass production costs, between 40 and 86 \$ per kg, it was concluded that open systems are more favorable compared to closed systems [110]. The results of this thesis confirm that closed systems, such as PBRs, are quite expensive in all aspects.

In Table 31 is shown the summary of process parameters and economic analysis of all the concepts.

Name		Conventional Biogas Plant	Biogas upgrade	Intensified Biogas Plant	Biogas-Fiber Biorefinery	Biogas-Algae Biorefinery (autotrophic growth)	Biogas-Algae Biorefinery (mixotrophic growth)
PROCESS (Biogas, fiber plant)	Substrate mass flow [kg <sub>TS</sub> s <sup>-1</sup> ]	0.152					
	OLR value [kg <sub>vs</sub> m <sup>-3</sup> d <sup>-1</sup> ]	2.00	2.00	1.25	2.50	2.00	
	Residence time [days]	50	50	40	20	50	
	Fermenter volume [m <sup>3</sup> ]	6 600	6 600	11 500	6 000	7 223	
	Biogas yield [Nm <sup>3</sup> t <sup>-1</sup> <sub>TS</sub> ]	509±58	509±58	633±52	100	605±17	
	Methane yield [Nm <sup>3</sup> t <sup>-1</sup> <sub>TS</sub> ]	243±49	243±49	362±43	55	343±11	
	Annual residuals production [ton]	1 750	1 750	1 150	-	1 200	
	Annual CO <sub>2</sub> release [ton]	5 300	1 850	5 450	1 250	7 100	
	CHP electric power [kW <sub>el</sub> ]	500	-	750	110	709	709
	Products, and by-products	Heat & electricity, residue	Biomethane, residue	Heat & electricity, residue	Fiber, heat & electricity	Heat & electricity, algae, residue	
PROCESS (Algae plant)	Algae specie [-]	N/A				<i>Chlorella vulgaris</i>	
	PBR type [-]					Co-annular	
	PBR working volume [L]					258	
	PBR area occupation [m <sup>2</sup> ]					14000	
	Light:Dark ratio [-]					22:2 (internal), 15:7 (external)	12:12 (internal and external)
	Consumable					BBM + sulfuric acid, every 3 days	BBM + sulfuric acid, every 2 days
	Productivity [g L <sup>-1</sup> d <sup>-1</sup> ]					0.15	
	Resident time [day]					10	
	Annual algae productivity [ton]					107.451	
	ECONOMIC ANALYSIS					TFCC [\$ mil.]	3.136
Fermenter percentage of ISBL		48%	47%	53%	40%	10%	
Purchased Capital Cost, algae plant:biogas plant [%]		N/A				77%	
Variable Operation Cost [\$ mil. y <sup>-1</sup> ]		0.09	0.20	0.32	0.55	4.7	4.51
Fixed Operation Cost [\$ mil. y <sup>-1</sup> ]		056	0.60	0.67	0.58	1.681	
Specific Investment[\$(TFCC) kW <sup>-1</sup> <sub>el</sub> ]		6 300	NA.	6 630	35 660	23 500	
Gross Profit [\$ mil. y <sup>-1</sup> ]		-0.07	0.33	-0.15	-0.72	-0.75	-0.52
Discounted payback period [year]		negative	17	negative	negative	negative	negative
NPV at the end of plant lifetime [mil. \$]	-3.3	-0.2	-5.6	-9.3	-21.4	-19.5	

Table 31. Summary table comprising of process, cost of production and economic analysis results

## 7.1 Sensitivity analysis

A sensitivity analysis was performed to evaluate the impact of specific parameters on the results of the economic analysis. The only meaningful sensitivity that can be conducted is the influence of the price of the key product, since the gross profit of all concepts, except for the biogas upgrade concept, was negative.

### 7.1.1 Sensitivity on electricity selling price

This sensitivity analysis specifically focuses on the variation of the electricity selling price. The results of the sensitivity analysis are presented in Figure 38, where the curves with legends demonstrate how the payback period changes with an increase in the electricity price. The biogas upgrade concept, where the key product is only biomethane, was not considered in this analysis. Additionally, the biogas-biorefinery concepts were not included as their electricity production is low enough to have any significant impact on the payback period.

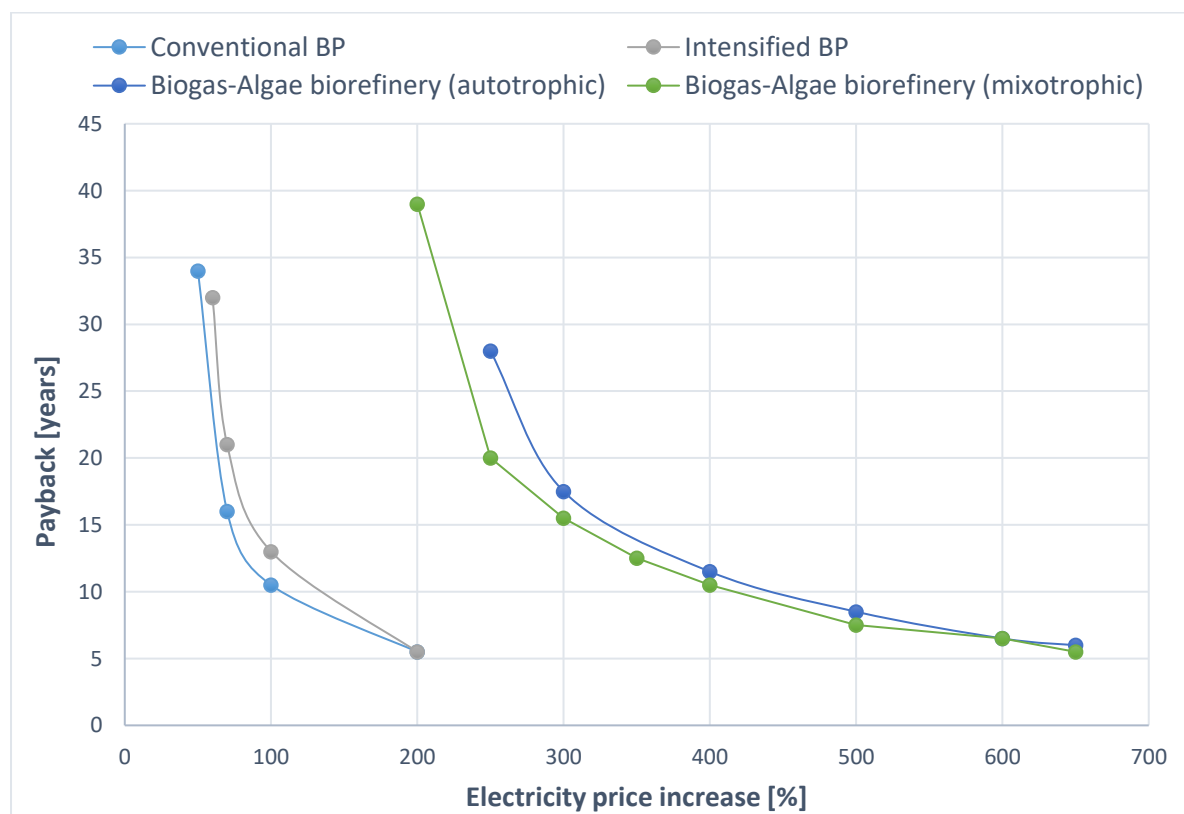

Figure 38. Sensitivity analysis, electricity price variation

As shown in Figure 38, the conventional and intensified biogas plants have an economically viable payback period of less than 5 years, starting from an increase in the electricity price

of 200%. Both biogas-algae biorefineries have a rentable payback period starting from an increase in the electricity price of 650%. The concepts with a "single" key product require a significantly smaller increase in electricity price to become economically viable.

### 7.1.2 Sensitivity on biomethane, fiber and algae selling price

This sensitivity analysis includes the variation of the selling price of biomethane, fiber, and algae.

The results, as shown in Figure 39, indicate that the biogas upgrade and both biogas-algae biorefineries have an economically viable payback period starting from a 150% increase in the selling price. For the biogas-fiber biorefinery, a rentable payback period starts from a 500% increase in the selling price.

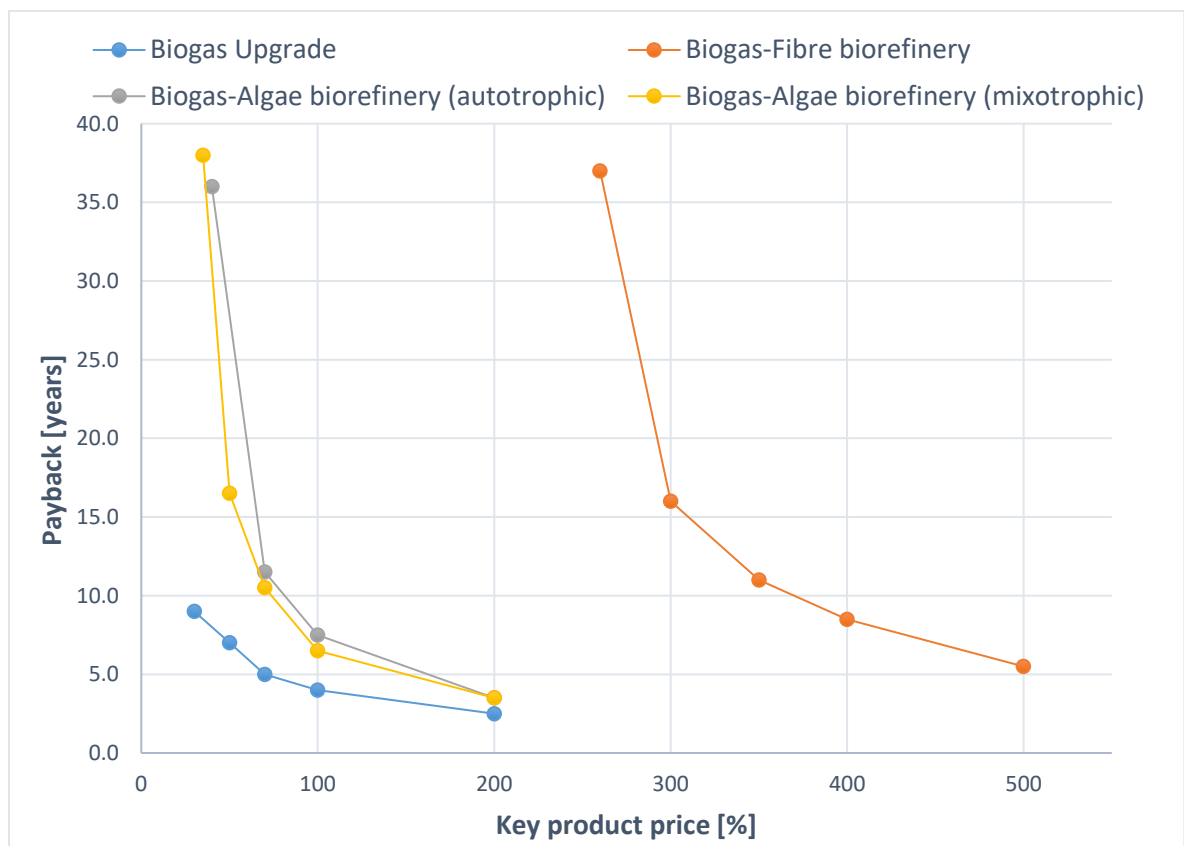

Figure 39. Sensitivity analysis, biomethane, fiber and algae price variation

### 6.1 Energy return of energy invested

The energy return on energy invested is a value that reflects the difference between the delivered and received energy. The energy return was estimated using the produced electricity, hot water, and methane, while the energy invested was only based on the used

electricity. As shown in Figure 40, the conventional BP, intensified BP, and biogas upgrade concept have a favorable energy return on energy invested compared to the energy invested.

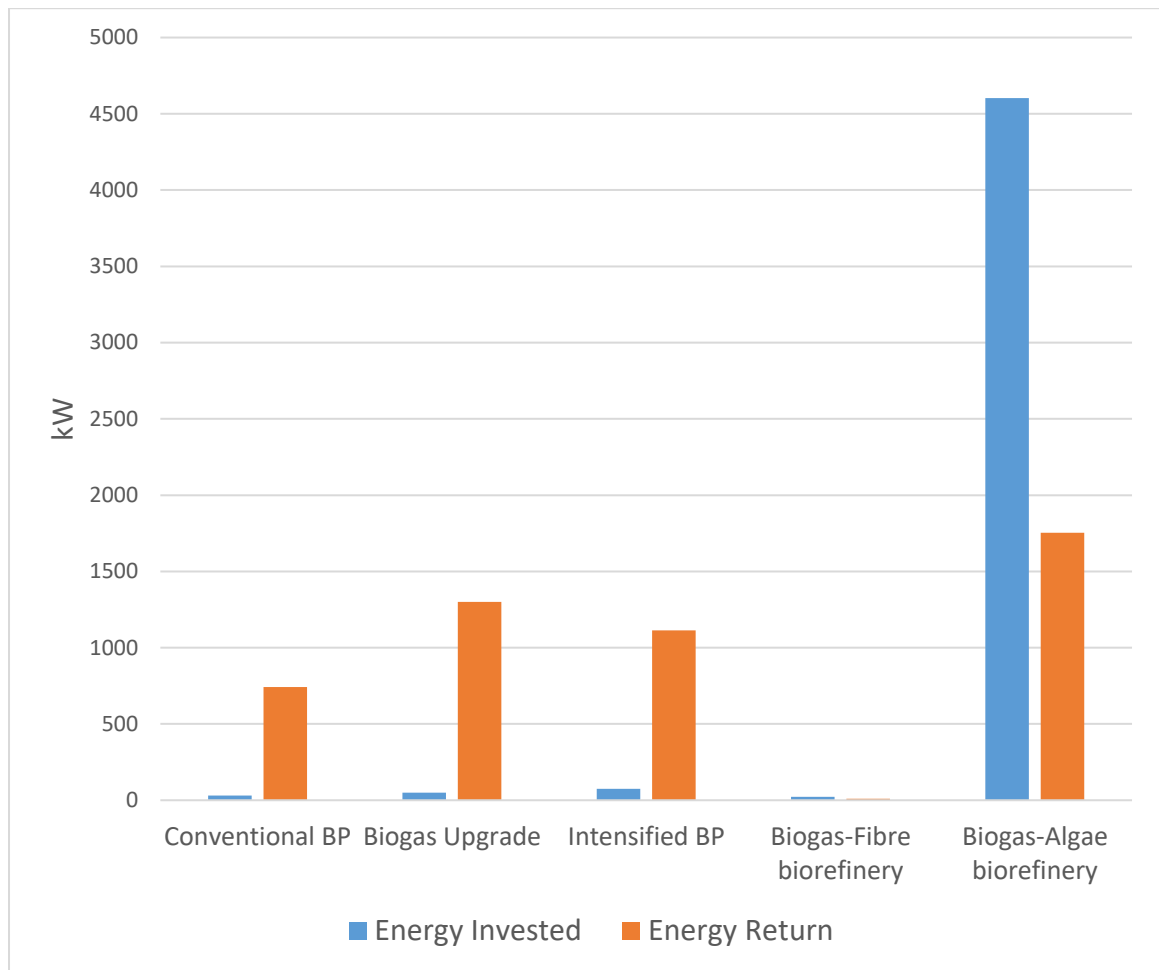

Figure 40. Energy Return vs. Energy Invested

## 6.2 SWOT analysis

A SWOT (Strengths, Weaknesses, Opportunities, and Threats) analysis was performed to gain a better understanding of the advantages and disadvantages of the biogas-algae biorefinery concept. This concept was chosen for analysis due to its potential for diverse production and various applications. However, the following SWOT analysis includes general points that can be applied to all the concepts discussed in the thesis.

<b>STRENGTH</b>	<b>OPPORTUNITIES</b>
<ul style="list-style-type: none"> <li>• Applicability of the different key-products, covering a few sectors (energy, transportation, agriculture, pharmacy, nutrition).</li> <li>• New technology based on two old and well-known industrially operating plants (conventional biogas plant, algae production in PBR)</li> <li>• Diversity of raw material for fermentation with no impact on algae cultivation.</li> <li>• Minimal by-products.</li> </ul>	<ul style="list-style-type: none"> <li>• Reduction of CO<sub>2</sub> emissions and overall environmental impact.</li> <li>• Production of renewable fuels.</li> <li>• Significant contribution to the sustainable future and fulfillment of global policies towards fossil fuel restrictions.</li> <li>• High applicability of high-values algae powder: nutrition, pharmacy, etc.</li> <li>• Increase people employment and bring to people new philosophy of sustainable future.</li> </ul>
<b>WEAKNESSES</b>	<b>THREATS</b>
<ul style="list-style-type: none"> <li>• Economic profitability, low interest for investors.</li> <li>• Relatively low annual specific production of algae comparing to plant occupied area.</li> <li>• Process sensitivity of mesophilic growth and algae cultivation conditions (constant lightening).</li> <li>• Due to the huge number of PBR, maintenance cost could increase within the time.</li> <li>• High demand for quality of high-value algae powder.</li> <li>• Increasing price of raw material significantly influence economic feasibility.</li> </ul>	<ul style="list-style-type: none"> <li>• Potential biogas flammability.</li> <li>• Possibility for stopping algae production after biogas plant shutdown.</li> <li>• For subsidized projects, sudden abruption of government support can stop the production due to unsustainability.</li> <li>• Strong dependence on legislation and local policy.</li> </ul>

*Table 32. SWOT analysis, biogas-algae biorefinery*

## 7 CONCLUSION

This doctoral thesis presents the technological design of five concepts in which biogas production is fundamental. Two of these concepts are biorefinery concepts that expand the production of key products beyond electricity. The raw material used in all concepts is wheat straw, which is fully utilized in a closed life-cycle loop. Wheat straw is produced on a farm, used for fermentation, and the fermentation residuals are used as fertilizer to cultivate new crops. In all concepts, apart from the exhaust gases produced from the burning of biogas, no other dangerous or harmful components are released into the atmosphere, making the production environmentally friendly. The water separated after fermentation or algae harvesting can be directly discharged to the nearest WWTP for conventional separation. In the case of the biogas-algae biorefinery, the exhaust gases are utilized, leading to a reduction in CO<sub>2</sub> emissions.

Each concept includes a techno-economic analysis that includes a PFD, mass and energy balance, and economic feasibility evaluation. The PFDs are designed to maximize energy regeneration and minimize waste. To validate the accuracy of the techno-economic calculations, a conventional biogas plant was designed based on a literature review. The key parameters of each equipment were estimated, and based on these estimates, the capital cost was determined.

This thesis presents several unique configurations of biogas biorefineries that combine various techniques of raw material pretreatment, such as mechanical disintegration and hydrothermal treatment, and product processing, such as the separation of cellulose fibers, biogas refining, and the use of CO<sub>2</sub> for microalgae production.

- ✓ Original parametric models were created for individual model technological configurations of the biogas biorefinery, which enabled a comparative evaluation of mass and energy balances, technical maturity, and design economics, including sensitivity analysis.
- ✓ The dissertation refutes the hypothesis that the design of BP in the biorefinery concept can achieve economic attractiveness without the implementation of subsidized product selling prices.
- ✓ Conventional BP showed that it could not be sustainable without subsidies. The electricity price is too low for economic feasibility. However, the production is well known, making the process more reliable and predominantly selectable.



- ✓ Biogas upgrade with current assumptions, free raw material mainly, showed the best sustainability, compared to the other concepts. The process is well known. However, the critical factor here is the price of biomethane.
- ✓ Intensified BP cannot be sustainable even having free raw material. Subsidies here play a crucial part. Also, the new pre-treatment method process cannot be completely reliable now.
- ✓ Biogas-fiber biorefinery showed the worst sustainability. In addition, the value of dry fiber is low, which means selling price growth cannot be foreseen.
- ✓ Both biogas-algae biorefineries showed their unsustainability. A critical factor is the selling price of algae. The demand for biogas and algae should go up in the future, making this concept quite promising.

The key parameters that impact project feasibility were selected and analyzed through sensitivity analysis. To attract investment in renewable energy sources, which are gradually replacing fossil fuels, it is expected that governments will introduce increased green tariffs for key-products. This scenario was simulated, and it was found that, even with the assumption of zero raw material price, the selling price of key-products needs to increase by 200% to achieve a viable payback period. Currently, only developed countries can afford such a policy supporting green tariffs. It should be noted that massive subsidization, even in developed countries, is not expected and there will always be limited government budgets dedicated to renewable energy sources.

Over the last century, the emissions of CO<sub>2</sub>, NO<sub>x</sub>, and other pollutants into the atmosphere have been consistently increasing, with exponential growth since the start of industrialization. Without financial viability for renewable energy plants, large-scale global construction cannot be expected. To make renewable energy projects feasible, further research is necessary to increase yields and reduce production costs.

A SWOT analysis was performed on the biogas plants and biorefineries based on biogas production, and several critical points were identified. In the case of the biogas-algae biorefinery, the specific algae production per area is low, and there seems to be no solution to significantly increase this value. The biogas and algae production processes are sensitive, and changes in operating temperature in the fermenter or photobioreactor can negatively affect mesophilic bacteria and algae species, respectively. In the biogas-fiber biorefinery, the separation of fibers is not justified as it reduces the potential for producing more biogas and electricity, and thus revenue, from the full volume of treated raw material.

The author's conclusion is that conventional and intensified biogas plants, as well as biogas upgrade, have advantages over biorefinery concepts. A single key-product approach leads to a simpler process, with less equipment required and lower capital costs. Chapter 7.1 provides evidence that the most favorable outlook favors plants that produce a single key-product.

Government regulations and policies play a crucial role in driving the development and implementation of renewable energy sources. Subsidization is considered as a key factor for the feasibility of renewable energy plants as they require initial investments. To support the growth of renewable energy, a portion of the annual government budget should be dedicated to renewables with a yearly increasing percentage. Countries should set targets to produce a certain amount of energy from renewable sources only and promote a renewable energy philosophy through education and public awareness programs.

It is expected that society will eventually recognize the need to adopt a more sustainable and renewable energy-focused lifestyle, which may require certain sacrifices.

## SYMBOLS

### Basic quantities

$a, b, n$	Correlation factors	—
$b_i$	Single component temperature-depended parameter	$mol\ kg^{-1}$
$C_e$	Capital cost	\$
$C_i^m$	Mass fraction of I component	%wt.
$C_R$	Energy constant	$kWh\ mm^{-1}\ t^{-1}$
$C_P$	Specific heat capacity at constant pressure	$kJ\ kg^{-1}\ K^{-1}$
$C_V$	Latent heat of evaporation	$kJ\ kg^{-1}$
$c$	Wheat straw to biogas conversion amount	%wt.
$k_{q,i}$	Langmuir parameter, coefficient of zeolite 5A	$mol\ kg^{-1}\ K^{-1}$
$k_{q,i}$	Langmuir parameter, coefficient of zeolite 5A	K
$\dot{m}_i$	Mass flow rate of $i$ component	$kg.\ s^{-1}$
$n$	Molar flow rate	$mol\ s^{-1}$
$\eta_E$	Efficiency for electricity production in cogeneration unit	—
$p_i$	Partial pressure of $i$ component	bar
$R$	Universal gas constant	$kJ\ kmol^{-1}\ K^{-1}$
$\dot{Q}$	Power	kW
$q_{CH_4}$	Combustion heat of methane	$kWh\ Nm^{-3}$
$q_i$	Absorbed phase concentration of $i$ component	$mol\ kg^{-1}$
$q_{max,i}$	Single component temperature-depended parameter	$mol\ kg^{-1}$
$Y_{CH_4}$	Methane yield	$Nm^3\ t_{TS}^{-1}$
$\alpha_{TS}$	Amount of dissolved wheat straw during pretreatment	%wt.

### Abbreviations

<i>ABE</i>	Acetone-Butanol-Ethanol
<i>ACC</i>	Annual Capital Charge
<i>AD</i>	Anaerobic Digestion
<i>AR</i>	Air
<i>Al<sub>2</sub>O<sub>3</sub></i>	Aluminum Oxide
<i>BBM</i>	Bold's Basal Media
<i>BG</i>	Biogas
<i>BOD</i>	Biological Oxygen Demand

<i>BP</i>	Biogas Plant
<i>BTL</i>	Biomass to liquid
<i>C</i>	Carbon
<i>CCOP</i>	Cash cost of production
<i>CEPCI</i>	Chemical Engineering Plant Cost Index
<i>CHP</i>	Combined Heat and Power
<i>CH<sub>4</sub></i>	Methane
<i>CNG</i>	Compressed Natural Gas
<i>CNTF</i>	Centrifuge
<i>C: N</i>	Carbon : Nitrogen
<i>COD</i>	Chemical Oxygen Demand
<i>CSTR</i>	Continuous Stirred Tank Reactor
<i>CO</i>	Carbon Monoxide
<i>CO<sub>2</sub></i>	Carbon Dioxide
<i>DRN</i>	Drying
<i>EX</i>	Exhaust
<i>FeCl<sub>2</sub></i>	Ferrous Chloride
<i>FeCl<sub>3</sub></i>	Iron Chloride
<i>FeSO<sub>4</sub></i>	Iron Sulfate
<i>FeS</i>	Iron Sulfide
<i>FCOP</i>	Fixed Production Cost
<i>FLCT</i>	Flocculant
<i>F – T</i>	Fischer-Tropsch
<i>GHG</i>	Green House Gas Emissions
<i>HRT</i>	Hydraulic Retention Time
<i>H</i>	Hydrogen
<i>H<sub>2</sub>S</i>	Hydrogen Sulfide
<i>H<sub>2</sub>O</i>	Water
<i>H<sub>2</sub></i>	Hydrogen
<i>IEA</i>	International Energy Agency
<i>IRR</i>	Interest Rate of Return
<i>ISBL</i>	Inside Battery Limit
<i>LNG</i>	Liquefied Natural Gas
<i>LCA</i>	Life-cycle Analysis
<i>LCB</i>	Lignocellulosic biomass

<i>LHV</i>	Low heating Value
<i>LNG</i>	Liquefied Natural Gas
<i>LPC</i>	Low Pressure Condensate
<i>LPS</i>	Low Pressure Steam
<i>M</i>	Moisture
<i>MgO</i>	Magnesium Oxide
<i>N</i>	Nitrogen
<i>N/A</i>	Not Applicable
<i>NEXBTL</i>	Neste Renewable Diesel
<i>NF</i>	Nelson-Farrer
<i>NPV</i>	Net Present Value
<i>NTR</i>	Nutrients
<i>NH<sub>3</sub></i>	Ammonia
<i>NO<sub>x</sub></i>	Nitrogen oxide
<i>NO<sub>2</sub><sup>-</sup></i>	Nitrogen dioxide
<i>NO<sub>3</sub><sup>-</sup></i>	Nitric Oxide
<i>N<sub>2</sub></i>	Nitrogen
<i>N<sub>3</sub></i>	Azide ion
<i>ODM</i>	Organic Loading Rate
<i>OLR</i>	Organic loading rate
<i>OSBL</i>	Outside Battery Limit
<i>O<sub>2</sub></i>	Oxygen
<i>PBR</i>	Photobioreactor
<i>PFD</i>	Process Flow Diagram
<i>pH</i>	Power of Hydrogen
<i>ppm</i>	Parts per Million
<i>PSA</i>	Pressure-swing Adsorption
<i>RSD</i>	Residuals
<i>S</i>	Sulfur
<i>SiO<sub>2</sub></i>	Silicon Dioxide
<i>SUS</i>	Suspension
<i>SWOT</i>	Strength-weakness-opportunities-threats
<i>SO<sub>H</sub><sup>2-</sup></i>	Sulfur Oxide
<i>S<sup>2-</sup></i>	Sulfide

<i>TCOP</i>	Cost of Production
<i>TFCC</i>	Total Fixed Capital Cost
<i>TS</i>	Total Solids
<i>UK</i>	United Kingdom
<i>USA</i>	United States of America
<i>USD</i>	US Dollar
<i>VS</i>	Volatile solids
<i>W</i>	Water
<i>WDTS</i>	Water dissolved total solids
<i>WCED</i>	World Commission on Environment and Development
<i>WR</i>	Returned water
<i>WWTP</i>	Wastewater treatment plant

## LIST OF FIGURES

Figure 1. Source of biomass [4].....	10
Figure 2. Estimated timeline for biorefinery deployment [6].....	10
Figure 3. Stages of LCA (DIN EN ISO 14040, p. 17) [11].....	12
Figure 4. Petrochemical, renewable feedstocks, and their derivatives [15] .....	13
Figure 5. Scheme of biorefinery process chain [22]......	17
Figure 6. Biomass syngas to diesel, simple visualization [23] .....	18
Figure 7. Cellulosic ethanol, simple visualization [25] .....	18
Figure 8. Biodiesel production, simple visualization .....	19
Figure 9. Worldwide Mandates and Subsidies. Current policy status in five major world regions [40] [41] [42] [43] [44] .....	26
Figure 10. Revenue Potential. There are significant revenue potentials along entire biomass value chain. The values given are approximate business potential in US\$ billions by 2020 [39].....	26
Figure 11. Process chain of anaerobic digestion [45].....	27
Figure 12. Mass balance of selected elements [1]. .....	35
Figure 13. Heat exchangers for water vapor reduction [52]......	36
Figure 14. Siloxane influence on engines [52]. .....	38
Figure 15. Biogas upgrading technologies via CO <sub>2</sub> removal [56]......	38
<i>Figure 16. General Scheme of Biogas Biorefinery [1] .....</i>	<i>40</i>
Figure 17. Schematic production of Patent US 9970032 B2 [63] .....	42
Figure 18. Biogas biorefinery strategies .....	46
Figure 19. Co-annular PBR [76].....	52
Figure 20. Mechanical size reduction, block diagram .....	53
Figure 21. Hydrothermal pretreatment, block diagram .....	54
Figure 22. Fermentation, block diagram.....	56
Figure 23. Digestate centrifuge, block diagram.....	58
Figure 24. Biogas Combustion, block diagram .....	59

Figure 25. Biogas upgrade, block diagram .....	60
Figure 26. Algae cultivation and harvesting, block diagram .....	62
Figure 27. Block diagram, conventional BP .....	74
Figure 28. Scheme for mass balance, conventional plant.....	76
Figure 29. Block diagram, Biogas upgrade .....	81
Figure 30. Scheme for mass balance, Biogas upgrade plant .....	82
Figure 31. Block diagram, Intensified BP .....	87
Figure 32. Scheme of mass balance, Intensified Biogas Plant .....	89
Figure 33. Block diagram, Biogas-Fiber biorefinery.....	94
Figure 34. TEP, 185 °C/40min .....	95
Figure 35. Scheme of mass balance, Biogas-Fiber Biorefinery .....	96
Figure 36. Block diagram, Biogas-Algae Biorefinery .....	102
Figure 37. Scheme of mass balance, Biogas-Algae Biorefinery .....	103
Figure 38. Sensitivity analysis, electricity price variation.....	115
Figure 39. Sensitivity analysis, biomethane, fiber and algae price variation .....	116
Figure 40. Energy Return vs. Energy Invested.....	117



## LIST OF TABLES

Table 1. CHO composition of crude oil, fats and oils, and lignocellulosic biomass [18] ...	14
Table 2. Commercial Biorefineries [27] [3] [33] [34] [35] [36].....	23
Table 3. Renewable Energy Feed-in Tariffs [38] .....	25
Table 4. Typical composition of biogas from biowaste [47] [27]. .....	30
Table 5. Principle of AD fermentation [48].....	30
Table 6. Biogas water vapor concentration with respect to temperature [52]. .....	36
Table 7. Overview of technologies .....	47
Table 8. Pre-treatment methods of substrate and biogas yield .....	49
Table 9. Economic model set-up .....	73
Table 10. Conventional Biogas Plant, mass balance .....	77
Table 11. Capital Cost, conventional biogas plant .....	79
Table 12. Electricity consumption data, conventional BP .....	79
Table 13. Cost of Production and Economic Analysis, conventional biogas plant. ....	80
Table 14. Biogas upgrade Plant, mass balance .....	83
Table 15. Capital Cost, biogas upgrade plant. ....	85
Table 16. Electricity consumption data, biogas upgrade .....	85
Table 17 Cost of Production and Economic Analysis, biogas upgrade plant. ....	86
Table 18. Intensified Biogas Plant, mass balance.....	90
Table 19. Capital Cost, intensified biogas plant. ....	92
Table 20. Electricity consumption data, intensified BP.....	93
Table 21. Cost of Production, intensified biogas plant.....	93
Table 22. Biogas-Fiber Biorefinery, mass balance.....	97
Table 23. Capital Cost, biogas-fiber biorefinery .....	99
Table 24. Electricity consumption data, Biogas-Fiber Biorefinery .....	99
Table 25. Cost of Production and Economic Analysis, biogas-fiber biogas plant .....	100
Table 26. Biogas-Algae Biorefinery, mass balance.....	105

Table 27. Capital Cost, biogas-algae biorefinery .....	107
Table 28. Electricity consumption data, Biogas-Algae Biorefinery .....	108
Table 29. Cost of Production and Economic Analysis, biogas-algae (autotrophic growth) .....	109
Table 30. Cost of Production and Economic Analysis, biogas-algae (mixotrophic growth) .....	110
Table 31. Summary table comprising of process, cost of production and economic analysis results .....	114
Table 32. SWOT analysis, biogas-algae biorefinery .....	118

## LIST OF REFERENCES

- [1] H. Lindorfer and B. Frauz, "Biogas Biorefineries," in *Industrial Biorefineries and White Biotechnology*, USA, ELSEVIER, 2015, pp. 271-294. ISBN: 978-0-444-63453-5.
- [2] B. Kamm, P. R. Gruber and M. Kamm, *Biorefineries - Industrial Processes and Products*, Germany: WILEY-VCH Verlag GmbH & Co., 2006. ISBN:9783527619849.
- [3] d. J. E, H. Langeveld and v. R. R, "IEA Bioenergy Task 42 Biorefinery," IEA Bioenergy, 2016.
- [4] A. Dahiya, *Bioenergy. Biomass to Biofuels*, USA: ELSEVIER, ISBN: 9780124081208, 2015.
- [5] P. Pandey, D. Lee, Y. Chisti and C. Soccol, *Biofuels from Algae*, USA: ELSEVIER, 2013. ISBN: 978-0-444-59558-4.
- [6] J. Sadkhukhan, K. S. Hg and E. M. H., *Biorefineries and Chemical Processes*, UK: John Wiley & Sons, Ltd, 2014. ISBN: 9781119990864.
- [7] N. Clark, "The end of the internal combustion engine?," Aljazeera media network, 27 November 2020. [Online]. Available: <https://www.aljazeera.com/features/2020/11/27/the-end-of-the-internal-combustion-engine>. [Accessed November 2021].
- [8] L. Schebek and O. Mrani, "Environmental and sustainability assessment of biorefineries," in *Advances in Biorefineries*, USA, Woodhead, 2015, pp. 67-88. ISBN: 978-0-85709-521-3.
- [9] C. Alles and R. Jenkins, "Integrated corn-based biorefinery: a study in sustainable process development," in *Sustainable Development in the Process Industries: Cases and Impact*, Wiley, 2010, pp. 157-179. ISBN: 978-0-470-18779-1.
- [10] L. Schebek, "Life-Cycle Analysis of Biobased Products," in *Renewable Raw Materials*, Germany, Wiley-VCH Verlag GmbH & Co. KGaA, 2011, pp. 187-216. ISBN: 978-3-527-63420-0.
- [11] "International Organization for Standardization, Environmental Management - Life Cycle Assessment - Principle and Framework," International Organization for

- Standardization, [Online]. Available: [http://www.iso.org/iso/iso\\_catalogue/catalogue\\_tc/catalogue\\_detail.htm?csnumber=37456](http://www.iso.org/iso/iso_catalogue/catalogue_tc/catalogue_detail.htm?csnumber=37456). [Accessed June 2022].
- [12] J. Speight, *The chemistry and technology of petroleum, USA*: CRC PRes, 2014. ISBN: 978-1439873892.
- [13] P. Harmsen, M. Hackman and H. Bos, "Green building blocks for bio-based plastics," *Biofuel Bioprod Biorefen*, vol. 8, no. 3, pp. 306-324, 2014. DOI: 10.1002/bbb.1468.
- [14] B. Highina, I. Bugaje and B. Umar, "A REVIEW ON SECOND GENERATION BIOFUEL: A COMPARISON OF ITS CARBON FOOTPRINTS," *European Journal of Engineering and Technology*, vol. 2, no. 2, pp. 117-125, 2014.
- [15] N. Qureshi, D. B. Hodge and A. A. Vertes, "Biorefinery Roadmaps," in *Biorefineries. Integrated Biochemical. Process for Liquid Biofuels*, USA, Elsevier, 2014, pp. 59-71. ISBN: 978-0444594983.
- [16] B.-b. I. Consortium, "European bioeconomy robust as bio-based industry turnover jumps to 780 billion EUR," October 2021. [Online]. Available: <https://biconsortium.eu/news/european-bioeconomy-figures-2018>. [Accessed January 2022].
- [17] T. Werpy and G. Petersen, "Top value added chemicals from biomass, volume 1 results of screening for potential candidates from sugar and sythesis gas," 2004. [Online]. Available: <http://www1.eere.energy.gov/biomass/pdfs/35523.pdf>. [Accessed February 2022].
- [18] d. J. E. and Jungmeier, "Biorefinery Concepts in Comparison to Petrochemical Refineries," in *Industrial Biorefineries and White Biotechnology*, USA, ELSEVIER, ISBN: 978-0-444-63453-5, 2015.
- [19] A. Kokossis and A. Yang, "On the use of systems technologies: a systematic approach for the sysnthesis and design of future biorefineries," *Comput Chem Eng*, vol. 9, no. 34, pp. 1397-1405, 2010. DOI: 10.1016/j.compchemeng.2010.02.021.
- [20] Neste, "Neste Annual Report 2019," 2019.
- [21] "Lectures Series: Intorductio to Bioenergy & Biofuels," Oregon State University, [Online]. Available: <http://agsci.oregonstate.edu/bioenergy-education/video-lectures>. [Accessed May 2021].

- [22] I. Bioenergy, "Biorefineries Roadmap," Federal Ministry of Food, Agriculture and Consumer Protection, Berlin , 2012.
- [23] R. Prasert, "ENRE, energy research," [Online]. Available: <http://www.enrethai.org/index.php/en/technology/46-fischer-tropsch-2>. [Accessed January 2022].
- [24] H. Boerrigter and R. Rauch, "Syngas production and utilisation," in *Handbook Biomass Gasification*, Vienna, Biomass Technology Group, ISBN: 9081006819, 2005.
- [25] R. F. Association, "Cellulosic Biofuels Industry Progress Report," 2012.
- [26] E. Gnansounou and A. Dauriat, "Ethanol from biomass: A review," *Journal of Scientific & Industrial Research*, vol. 64, no. 11, pp. 809-821, 2005.
- [27] C. Baskar, S. Baskar and R. Dhillon, *Biomass Conversion*, Berlin: Springer, 2012. ISBN: 978-3-642-28417-5.
- [28] N. Nguyen, "Optimization of Biodiesel Production plants," University of Nebraska-Lincoln, 2012.
- [29] F. Muller-Langer, S. Majer and S. O'keefe, "Benchmarking biofuels - a consumption of technical, economic and environmental indicators," *Energy, Sustainable and Society*, vol. 20, no. 4, 2014. DOI:10.1186/s13705-014-0020-x.
- [30] "Technology roadmaps - biofuels for transport.," IEA, Paris, 2011.
- [31] P. Shikida, A. Finco, B. Cardoso, V. Galnte, D. Rahmeier, D. Bentivoglio and M. Rasetti, "A Comparison Between Ethanol and Biodiesel Production: The Brazilian and European Experiences," *Liquid Biofuels*, vol. 27, pp. 25-53, 2014. DOI:10.1007/978-1-4471-6482-1\_2.
- [32] W. B. Association, "Global Bioenergy Statistics 2019," 2019.
- [33] S. Khanal, R. Surampali, T. Zhang, B. Lamsal, R. Tyagi and C. Kao, *Bioenergy and Biofuel from Biowastes and Biomass*, USA: American Society of Civil Engineers , 2010.

- [34] H. Holleman, "IEA Bioenergy Task 42 Biorefining," IEA Bioenergy, Wageningen, 2014.
- [35] J. Kantola, "Biorefineries in Europe," NC Partnering, Oulu, 2020.
- [36] B. Annevelink, L. G. Chavez, R. van Ree and I. V. Gursel, "Global biorefinery status report 2022," IEA Bioenergy, 2022.
- [37] C. Fruhmann and A. Tuerk , "Renewable Energy Support Policies in Europe," Climate Policy Info Hub, 3 November 2014. [Online]. Available: <http://climatepolicyinfohub.eu/renewable-energy-support-policies-europe>. [Accessed July 2022].
- [38] OECD, "Renewable energy feed-in tariffs," OECD, April 2020. [Online]. Available: [https://stats.oecd.org/Index.aspx?DataSetCode=RE\\_FIT#](https://stats.oecd.org/Index.aspx?DataSetCode=RE_FIT#). [Accessed March 2022].
- [39] D. King, "The Future of Industrial Biorefineries," World economic forum, Geneva, 2010.
- [40] G. Energy, "Renewable capacity in Brazil to exceed 60GW in 2030 in Brazil," Power Technology, July 2019. [Online]. Available: <https://www.power-technology.com/comment/brazil-renewable-capacity-2030/>. [Accessed March 2022].
- [41] "Renewable energy targets," European Commission, [Online]. Available: [https://energy.ec.europa.eu/topics/renewable-energy/renewable-energy-directive-targets-and-rules/renewable-energy-targets\\_en](https://energy.ec.europa.eu/topics/renewable-energy/renewable-energy-directive-targets-and-rules/renewable-energy-targets_en). [Accessed March 2022].
- [42] H. Min, "Can China's 14th 5-year-plan for Renewable Energy deliver an early emissions peak before 2030?," energypost.eu, July 2022. [Online]. Available: <https://energypost.eu/can-chinas-14th-5-year-plan-for-renewable-energy-deliver-an-early-emissions-peak-before-2030/>. [Accessed September 2022].
- [43] S. Singh, "India keeps renewables target flexible, goal of 500 GW green energy by 2030 dropped," The Economic Times, August 2022. [Online]. Available: <https://economictimes.indiatimes.com/industry/renewables/india-keeps-renewables-target-flexible-goal-of-500-gw-green-energy-by-2030-dropped/articleshow/93357477.cms>. [Accessed February 2022].

- [44] "FACT SHEET: President Biden Sets 2030 Greenhouse Gas Pollution Reduction Target Aimed at Creating Good-Paying Union Jobs and Securing U.S. Leadership on Clean Energy Technologies," The White House. [Online]. [Accessed May 2022].
- [45] Y. Vogeli, C. R. Lohri, A. Gallardo, S. Diener and C. Zurbrugg, *Anaerobic Digestion of Biowaste in Developing Countries*, Laufenburg: Eawag, 2014. ISBN: 978-3-906484-58-7.
- [46] D. Deublin and A. Steinhauser, *Biogas from Waste and Renewable Resources*, Weinheim: WILEY-VCH, ISBN: 9783527621705 , 2011.
- [47] J. Murphy, D. Baxter and A. Wellinger, *The Biogas Handbook: Science, production and applications*, Sawston, UK: Woodhead Publishing Limited, 2013. ISBN: 978-0-85709-741-5.
- [48] D. Pokorna and J. Zabranska, *Biogeochemické cykly biogenních prvků*, Praha: VSCHT, 2017.
- [49] B. Eder and H. Schulz, *Bioplyn v praxi*, HEL, ISBN: 80-86167-21-6, 2004.
- [50] FNR, "Guide to Biogas - From Production to Use," Deutsches BiomasseForschungsZentrum, 2012.
- [51] P. Vandevivere, L. D. Baere and W. Verstraete, "Types of anaerobic digester for solid wastes," in *Biomethanization of the organic fraction of municipal solid wastes*, Barcelona, IWA Publishing , 2002, pp. 111-140. ISBN: 9781900222143.
- [52] J. Zabranska and D. Pokorna, *Technologie výroby bioplynu a biovodíku*, Prague: UCT Prague, 2017.
- [53] G. MacKenzie, "Internal Combustion Engines," Water Environment Federation, Alexandria, 2017.
- [54] C. Deed, J. Gronow and A. Rosevear, "Guidance on gas treatment technologies for landfill gas engines," Environment Agency, Bristol, 2004.
- [55] P. Kougias, L. Treu, D. Benavente, K. Boe, S. Campanaro and I. Angelidaki, "Ex-situ biogas upgrading and enhancement in different reactor systems.," *Bioresour. Technology*, vol. 225, pp. 429-437, 2017. DOI: 10.1016/j.biortech.2016.11.124.

- [56] A. I. Adnan, M. Y. Ong, S. Nomanbhay, K. W. Chew and P. L. Show, "Technologies for Biogas Upgrading to Biomethane: A Review," *Bioengineering*, vol. 6, no. 92, pp. 1-23, 2019. DOI: 10.3390/bioengineering6040092.
- [57] U. Khan, T. E. Lee, M. A. Bashir, D. Dissanayake, Y. S. Ok, Y. W. Tong, M. A. Shariati, S. Wu and K. Ahring, "Current status of biogas upgrading for direct biomethane use: A review," *Renewable and Sustainable Energy Reviews*, vol. 149, no. 3, 2021. DOI: 10.1016/j.rser.2021.111343.
- [58] S. Holm, J. Ejlertsson and B. Carlson , "Method and device for producing biogas". USA Patent 20060102560, 18 05 2006.
- [59] J. Jensen and P. Jensen, "A BIOGAS PRODUCING FACILITY WITH ANAEROBIC HYDROLYSIS". Denmark Patent WO/2005/000748, 2 06 2004.
- [60] J. W. Van Groenestijn and G. Maurists Bos, "PROCESS FOR THE PRODUCTION OF BIOGAS". USA Patent US 2010/0015680 A1, 10 10 2007.
- [61] N. Mate, S. R. Gondhalekar and A. P. Joshi, "Pretreatment of agricultural residue as feeds to produce biogas". India Patent WO2010046915A2, April 2010.
- [62] V. F. Puentes, E. E. Gonzalez, E. C. Mercadal, A. G. Mester, L. D. Ramisa, X. F. Segura and A. S. Ferrer, "Biogas production". USA Patent US9416373B2, January 2014.
- [63] J. A. Silverman, S. M. Resnick and M. Mendez, "Biorefinery system, methods and compositions thereof". USA Patent US9970032B2, 02 2016.
- [64] M. Kapoor, D. Panwar and G. Kaira, "Bioprocesses for Enzyme Production Using Agro-Industrial Wastes: Technical Challenges and Commercialization Potential," in *Agro-Industrial Wastes as Feedstock for Enzyme Production*, Elsevier, 2016, pp. 61-93. ISBN: 978-0-12-802392-1.
- [65] L. Krátký and T. Jirout, *Moderní trendy předuprav biomasy*, 1 ed., Prague: Česká technika-nakladatelství, 2015. ISBN: 978-80-01-05720-9.
- [66] F. David, *Cogeneration. A user's guide.*, London: The Institution of Engineering and Technology, ISBN: 9781849191043, 2010.



- [67] J. Doucha, F. Straka and K. Livansky, "Utilization of flue gas for cultivation of microalgae (*Chlorella* sp.) in an outdoor open thin-layer photobioreactor," *Journal of Applied Phycology*, vol. 17, no. 5, pp. 403-413, 2005. DOI:10.1007/s10811-005-8701-7.
- [68] A. Pourmovahed, T. Opperman and B. Lemke, "Performance and Efficiency of a Biogas CHP System Utilizing a Stirling Engine," in *International Conference on Renewable Energies and Power Quality*, Las Palmas de Gran Canaria, 2011.
- [69] L. Krátký and T. Jirout, "The effect of process parameters during the thermal-expansive pretreatment of wheat straw on hydrolysate quality and on biogas yield," *Renewable Energy*, vol. 77, pp. 250-258, 2015. DOI: 10.1016/j.renene.2014.12.026.
- [70] L. Krátký and T. Jirout, "Mechanical disintegration of wheat straw using a roller-plate grinding system with sharp-edged segments," *Acta Polytechnica*, vol. 55, no. 2, pp. 113-122, 2015. DOI:10.14311/AP.2015.55.0113.
- [71] V. 6310, *Classification and quality criteria of biorefineries*, Dusseldorf: Verein Deutscher Ingenieure e.V., 2016.
- [72] P. Pedroni, J. Davison, H. Beckert, P. Bergman and J. Benemann, "A Proposal to Establish an International Network on Biofixation of CO<sub>2</sub> and Greenhouse Gas Abatement with Microalgae," EniTechnologie Research Facility, Monterotondo, 2001.
- [73] L. Brennan and P. Owende, "Biofuels from microalgae—A review of technologies for production, processing, and extractions of biofuels and co-products," *Renewable and Sustainable Energy Reviews*, vol. 14, no. 2, pp. 557-577, 2010. DOI:10.1016/j.rser.2009.10.009.
- [74] C. Safi, B. Zebib, O. Merah, P. Pontalier and C. Vaca-Garcia., "Morphology, composition, production, processing and applications of *Chlorella vulgaris*: A review.," *Renewable and Sustainable Energy Reviews*, vol. 35, pp. 265-278, 2014. DOI: 10.1016/j.rser.2014.04.007.
- [75] K.-L. Yeh and J.-S. Chang, "Effect of light supply and carbon source on cell growth and cellular composition of a newly isolated microalga *Chlorella vulgaris* ESP-31," *Bioresource Technology*, vol. 10, no. 3, pp. 201-208, 2010. DOI:10.1002/elsc.200900116.

- [76] N. Chavada, "Optimization of Vertical Photobioreactors," Universtiy of Dayton, Dayton, 2012.
- [77] P. Laboratories, "Bold's Basal Medium," 2017. [Online]. Available: <https://phytotechlab.com/bold-s-basal-medium-bbm.html>. [Accessed May 2022].
- [78] G. Tolwer and R. Sinnott, Chemical Engineering Design, London: Elsevier, 2013. DOI: 978-0-08-096659-5.
- [79] "Renewable Energy Sources Act (EEG 2017)," [Online]. Available: [https://www.bmwi.de/Redaktion/EN/Downloads/renewable-energy-sources-act-2017.pdf?\\_\\_blob=publicationFile&v=3](https://www.bmwi.de/Redaktion/EN/Downloads/renewable-energy-sources-act-2017.pdf?__blob=publicationFile&v=3). [Accessed January 2022].
- [80] D. Balussou, A. Kleybocker, R. McKenna, D. Most and F. Wolf, "An economic Analysis of Three Operational Co-digestion Biogas Plants in Germany," *Waste Biomass Valor*, no. 3, pp. 23-41, 2012. DOI:10.1007/s12649-011-9094-2.
- [81] Eurostat, "Archive:Energy price statistics," Eurostat, 5 December 2017. [Online]. Available: [https://ec.europa.eu/eurostat/statistics-explained/index.php?title=Archive:Energy\\_price\\_statistics#Electricity\\_prices\\_for\\_industrial\\_consumers](https://ec.europa.eu/eurostat/statistics-explained/index.php?title=Archive:Energy_price_statistics#Electricity_prices_for_industrial_consumers). [Accessed November 2021].
- [82] E. Water News, "Water prices compared in 36 EU-cities," Water News, Europe, 19 March 2021. [Online]. Available: <https://www.waternewseurope.com/water-prices-compared-in-36-eu-cities/>. [Accessed May 2022].
- [83] "100mm Rockwool RollBatt Loft Insulation," Insulation Shop, [Online]. Available: [https://www.insulationshop.co/rockwool\\_rollbatt\\_loft\\_insulation\\_100mm.html](https://www.insulationshop.co/rockwool_rollbatt_loft_insulation_100mm.html). [Accessed March 2022].
- [84] B. Participants, "D1.2. COST AND ECONOMIC FEASIBILITY GUIDE FOR LARGE SCALE MICROALGAL BIOREFINERIES," in *SABANA*, 2018.
- [85] Swagelok, "Knowing the Cost of Steam," Swagelok Energy Advisor, Inc., 2021.
- [86] R. Fischer, "Average Salary In European Union 2015," 15 March 2018. [Online]. Available: <https://www.reinisfischer.com/average-salary-european-union-2015>. [Accessed June 2022].

- [87] Avalara, "European Union VAT rates," [Online]. Available: <https://www.avalara.com/vatlive/en/vat-rates/european-vat-rates.html>. [Accessed April 2022].
- [88] S. Razack, S. Durajarasan, A. Santhalin Shellomith and K. Muralikrishnan, "Statistical optimization of harvesting *Chlorella vulgaris* using a novel bio-source, *Strychnos potatorum*," *Biotechnology Reports*, vol. 7, pp. 150-156, 2015. DOI: 10.1016/j.btre.2015.06.006.
- [89] R. P. Chemicals, "Sulfuric Acid 0.1N," [Online]. Available: <https://www.rightpricechemicals.com/sulfuric-acid-0-1n.html>. [Accessed December 2021].
- [90] C. Wang, A. F. Seibert and G. T. Rochelle, "Packing characterization: Absorber economic analysis," *International Journal of Greenhouse Gas Control*, vol. 42, pp. 124-131, 2015. DOI: 10.1016/j.ijggc.2015.07.027.
- [91] J. Reith, R. Wijffels and H. Barten, *Bio-methane & Bio-hydrogen*, Hague: Dutch Biological Hydrogen Foundation, 2003. ISBN: 90-9017165-7.
- [92] S. Bayr, *Biogas Production for Meat and Pulp and Paper Industry By-Products*, Jyväskylä: University of Jyväskylä, ISBN: 978-951-39-5680-6, 2014.
- [93] f. f. s.r.o., "Ceník litých podlah," 2021. [Online]. Available: <https://www.fabryfloors.cz/cenik-litych-podlah>. [Accessed November 2021].
- [94] J. Benemann, "Microalgae for Biofuels and Animal Feeds," *Energies*, vol. 6, pp. 5869-5886, 2013. DOI:10.3390/en6115869.
- [95] J. Milledge and S. Heaven, "Disc Stack Centrifugation Separation and Cell Disruption of Microalgae: A Technical Note," *Environment and Natural Resources Research*, vol. 1, pp. 17-24, 2011. DOI: 10.5539/ENRR.V1N1P17.
- [96] W. Steiger and M. Wimmer, "Energy-Efficient Algae Harvesting," *F & S International Edition*, 2012.
- [97] Buchi, "Application note: No. 245-2016, Spray drying of microalgae," Buchi, 2016.

- [98] Xingyu, "Products," 2016. [Online]. Available: [http://www.xydryer.com/Products/Product\\_3.htm](http://www.xydryer.com/Products/Product_3.htm). [Accessed December 2022].
- [99] SOLAR-COMPONENTS, "Solar Components Corporation," 2016. [Online]. Available: <http://www.solar-components.com/>. [Accessed May 200].
- [100] T. H. Depot, "The Home Depot," 2018. [Online]. Available: <https://www.homedepot.com/p/Philips-40-Watt-4-ft-ALTO-Supreme-Linear-T12-Fluorescent-Light-Bulb-Cool-White-4100K-10-Pack-422675/203466573>. [Accessed September 2021].
- [101] FIXR, "Concrete Foundation Cost," January 2016. [Online]. Available: <http://www.fixr.com/costs/concrete-foundation>. [Accessed March 2021].
- [102] "Greenhouse Megastore," 2018. [Online]. Available: <https://www.greenhousemegastore.com/structures/engineered-greenhouses/>. [Accessed May 2022].
- [103] F. B. II, "61 Biogasanlagen in Vergleich, Fachagentur Nachwachsende Rohstoffe e.V.," 2009.
- [104] R. Davis, A. Aden and P. T. Pienkos, "Techno-economic analysis of autotrophic microalgae for fuel production," *Applied Energy*, vol. 88, no. 10, pp. 3524-3531, 2011. DOI: 10.1016/j.apenergy.2011.04.018.
- [105] S. Nagarajan, S. K. Chou, S. Cao, C. Wu and Z. Zhou, "An updated comprehensive techno-economic analysis of algae biodiesel," *Bioresour. Technol.*, vol. 145, pp. 150-156, 2013. DOI: 10.1016/j.biortech.2012.11.108.
- [106] T. J. Lundquist, I. C. Woertz, N. Quinn and J. Benemann, "A Realistic Technology and Engineering Assessment of Algae Biofuel Production," University of California, Berkley, California, 2010.
- [107] Y. Chisti, "Raceway-based production of algae crude oil," *Microalgae biotechnology*, vol. 3, no. 3-4, pp. 113-146, 2012. DOI: 10.1515/green-2013-0018.
- [108] J. Liu, J. Huang, K. Fan, Y. Zhong, Z. Sun and F. Chen, "Production potential of *Chlorella zofingiensis* as a feedstock for biodiesel," *Bioresour. Technol.*, vol. 101, no. 22, pp. 8658-8663, 2010. DOI: 10.1016/j.biortech.2010.05.082.

- [109] Y. Chisti, "Biodiesel from microalgae," *biotechnology Advances*, vol. 25, no. 3, pp. 294-306, 2007. DOI: 10.1016/j.biotechadv.2007.02.001.
- [110] G. Thomassen, U. E. Vila, M. Van Dael, B. Lemmens and S. Van Passel, "A techno-economic assessment of an algal-based biorefinery," *Clean technologies and Environment Policy*, vol. 18, no. 6, pp. 1849-1862, 2016. DOI: 10.1007/s10098-016-1159-2.

## LIST OF OWN REFERENCES

### Articles in refereed journals

[AK1] A. Kutsay, L. Krátký and T. Jirout, "Biogas Plant Upgrade to CO<sub>2</sub>-Free Technology: A Techno-Economic Case study," *Chemical Engineering & Technology*, vol. 43, no. 10, pp. 1981-1993, 2020. DOI: 10.1002/ceat.202000134.

[AK2] A. Kutsay, L. Krátký and T. Jirout, "Diversity of Biogas Plant Realizations", *Chemical Engineering & Technology*, vol. 42, no. 12, pp. 370-380, 2019. DOI: 10.1002/ceat.201800362.

[AK3] A. Kutsay, L. Krátký and T. Jirout, "Energy-Economic Analysis of Thermal-Expansionary Pretreatment for Its Implementation at a Biogas Plant" *Chemical Engineering & Technology*, vol. 39, no. 12, pp. 2284-2292, 2016. DOI:10.1002/ceat.201500732.

### Conference proceedings, full papers

[AK4] A. Kutsay, L. Krátký, T. Jirout, "Biogas Biorefinery: Techno-Economic Analysis of Several Paths", In: *Proceedings of the 25th EUBCE - Stockholm 2017*. Florencie: ETA - Florence, 2017. pp. 1214-1225. ISSN 2282-5819. ISBN 978-88-89407-17-2.

[AK5] L. Krátký, T. Jirout, A. Kutsay, "Biorefinery: A Critical Technical Review", In: *Proceedings of the 25th EUBCE - Stockholm 2017*. Florencie: ETA - Florence, 2017. pp. 1294-1300. ISSN 2282-5819. ISBN 978-88-89407-17-2.

[AK6] A. Kutsay, L. Krátký, T. Jirout, "Technology of biogas production as a biorefinery concept", In: *Sborník příspěvků TVIP 2017*. Praha: CEMC - České ekologické manažerské centrum, 2017. ISBN 978-80-85990-30-0.

[AK7] L. Krátký, T. Jirout, A. Kutsay, "Perspektivita zpracování odpadů v biorafineriích", In: *Sborník příspěvků TVIP 2017*. Praha: CEMC - České ekologické manažerské centrum, 2017. ISBN 978-80-85990-30-0.

[AK8] A. Kutsay, L. Krátký, T. Jirout, "Biorefinery: An economic feasible waste transformation technology", In: *Venice 2016 - Sixth International Symposium on Energy from Biomass and Waste*. Proceedings. CISA Publisher, 2016. ISBN 9788862650076.

[AK9] A. Kutsay, L. Krátký, “Energeticko-ekonomické posouzení intenzifikované výroby bioplynu pomocí termicko-expanzní předúpravy”, In: Sborník konference CHISA 2015. Praha: Česká společnost chemického inženýrství, 2015.

[AK10] A. Kutsay, L. Krátký, “Energy-economic study of thermal-expansive pretreatment for its implementation at biogas plant”, In: 23rd European Biomass Conference and Exhibition Proceedings, EUBCE 2015. Florencie: ETA - Florence, 2015, ISSN 2282-5819. ISBN 978-88-89407-51-6.

#### Conference proceedings, abstracts

A. Kutsay, L. Krátký, T. Jirout, “Biogas Biorefinery: Techno-Economic Analysis”, In proceedings of the 7th International Conference on Engineering for Waste and Biomass Valorisation, WasteENG 2018, Prague

A. Kutsay, L. Krátký, T. Jirout, “Biorefinery: An economic feasible waste transformation technology?”, In: 22nd International Congress of Chemical and Process Engineering. Praha: Česká společnost chemického inženýrství, 2016.

A. Kutsay, L. Krátký, “Thermal-Expansive Pretreatment of Lignocellulosic Biomass: An Energy Feasibility Study”, In: Studentská tvůrčí činnost 2015. Praha: České vysoké učení technické v Praze, Fakulta strojní, 2015, ISBN 978-80-01-05727-8. Available from: [http://stc.fs.cvut.cz/pdf15/5537.pdf?\\_=1428514335](http://stc.fs.cvut.cz/pdf15/5537.pdf?_=1428514335)

#### Conference contribution, poster

A. Kutsay, L. Krátký, T. Jirout, “Biogas Biorefinery: Techno-Economic Analysis”, In WasteENG 2018.

A. Kutsay, L. Krátký, T. Jirout, “Technology of biogas production as a biorefinery concept”, In TVIP 2017.

A. Kutsay, L. Krátký, T. Jirout, “Biogas Biorefinery: Techno-Economic Analysis of Several Paths”, In EUBCE 2017.

A. Kutsay, L. Krátký, T. Jirout, “Biorefinery: An economic feasible waste transformation technology”, In Venice, Sixth International Symposium on Energy from Biomass and Waste 2016.

A. Kutsay, L. Krátký, T. Jirout, “Biorefinery: An economic feasible waste transformation technology?”, In CHISA 2016.

A. Kutsay, L. Krátký, “Energeticko-ekonomické posouzení intenzifikované výroby bioplynu pomocí termicko-expanzní předúpravy”, In CHISA 2015.

A. Kutsay, L. Krátký, “Energy-economic study of thermal-expansionary pretreatment for its implementation at biogas plant”, In EUBCE 2015.



## APPENDICES

- A1. Conventional biogas plant, Mass balance
- A2. Conventional biogas plant, Heat balance
- A3. Conventional biogas plant, Mass balance scheme
- A4. Conventional biogas plant, Flow sheet
- A5. Conventional biogas plant, Economic analysis
- B1. Biogas upgrade, Mass balance
- B2. Biogas upgrade, Heat balance
- B3. PSA, Column design
- B4. Biogas upgrade, Mass balance scheme
- B5. Biogas upgrade, Flow sheet
- B5. Biogas upgrade, Economic analysis
- C1. Intensified biogas plant, Heat and mass balance
- C2. Intensified biogas plant, Mass balance scheme
- C3. Intensified biogas plant, Flow sheet – intensified pre-treatment
- C4. Intensified biogas plant, Flow sheet - biogas production
- C5. Intensified biogas plant, Economic analysis
- D1. Biogas-fiber biorefinery, Heat and mass balance
- D2. Biogas-fiber biorefinery, Mass balance scheme
- D3. Biogas-fiber biorefinery, Flow sheet – intensified pre-treatment
- D4. Biogas-fiber biorefinery, Flow sheet – biogas-fiber
- D5. Biogas-fiber biorefinery, Economic analysis
- E1. Biogas-algae biorefinery, Heat and mass balance
- E2. Biogas-algae biorefinery, Mass balance scheme
- E3. Biogas-algae biorefinery, Flow sheet – biogas production
- E4. Biogas-algae biorefinery, Flow sheet – algae production
- E5. Biogas-algae biorefinery, Algae unit and PBR arrangement
- E6. Biogas-algae biorefinery, Economic analysis – autotrophic growth
- E7. Biogas-algae biorefinery, Economic analysis – mixotrophic growth

A4. Conventional biogas plant, Flow sheet

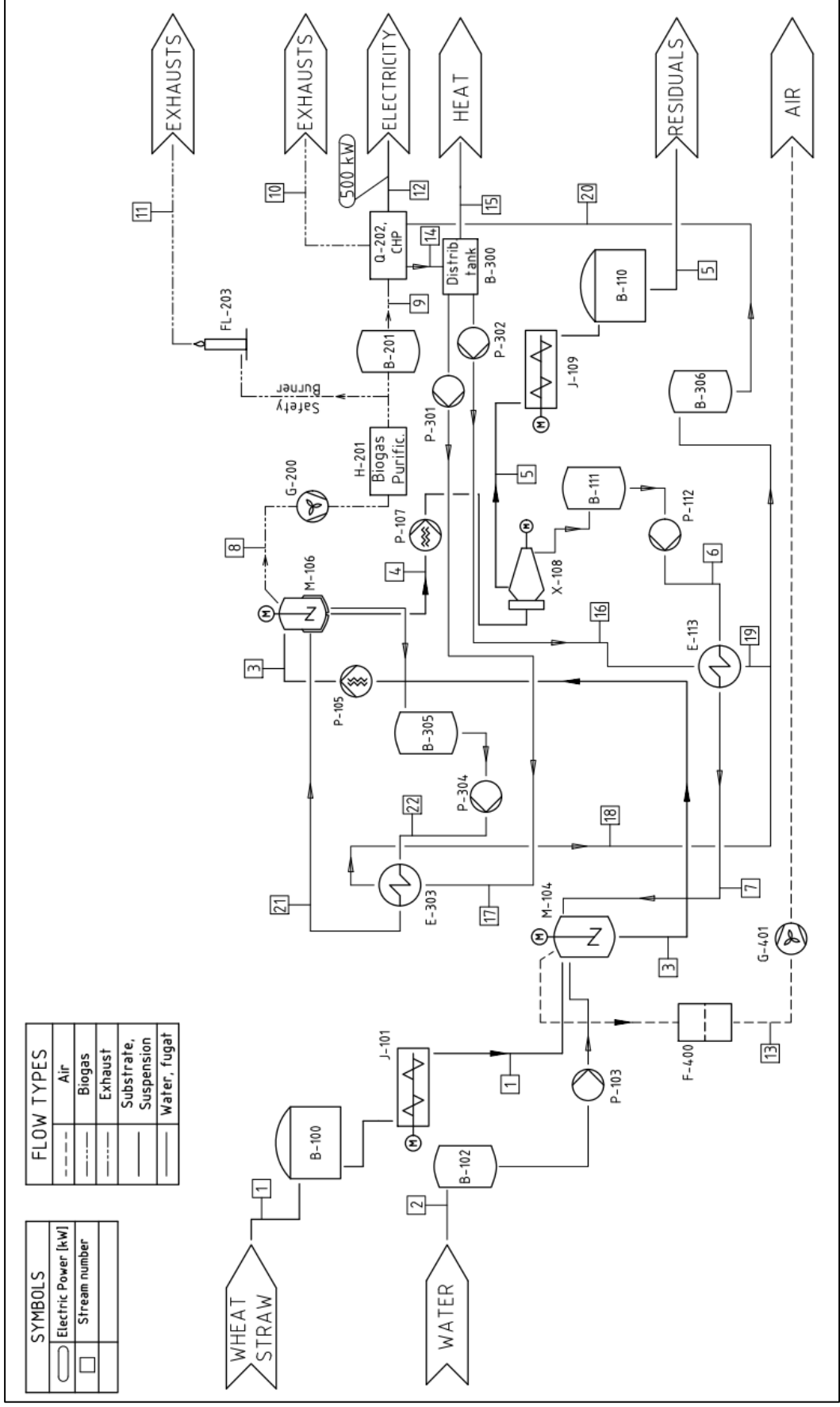

SYMBOLS	
	Electric Power [kW]
	Stream number

FLOW TYPES	
	Air
	Biogas
	Exhaust
	Substrate, Suspension
	Water, fugat

B5. Biogas upgrade, Flow sheet

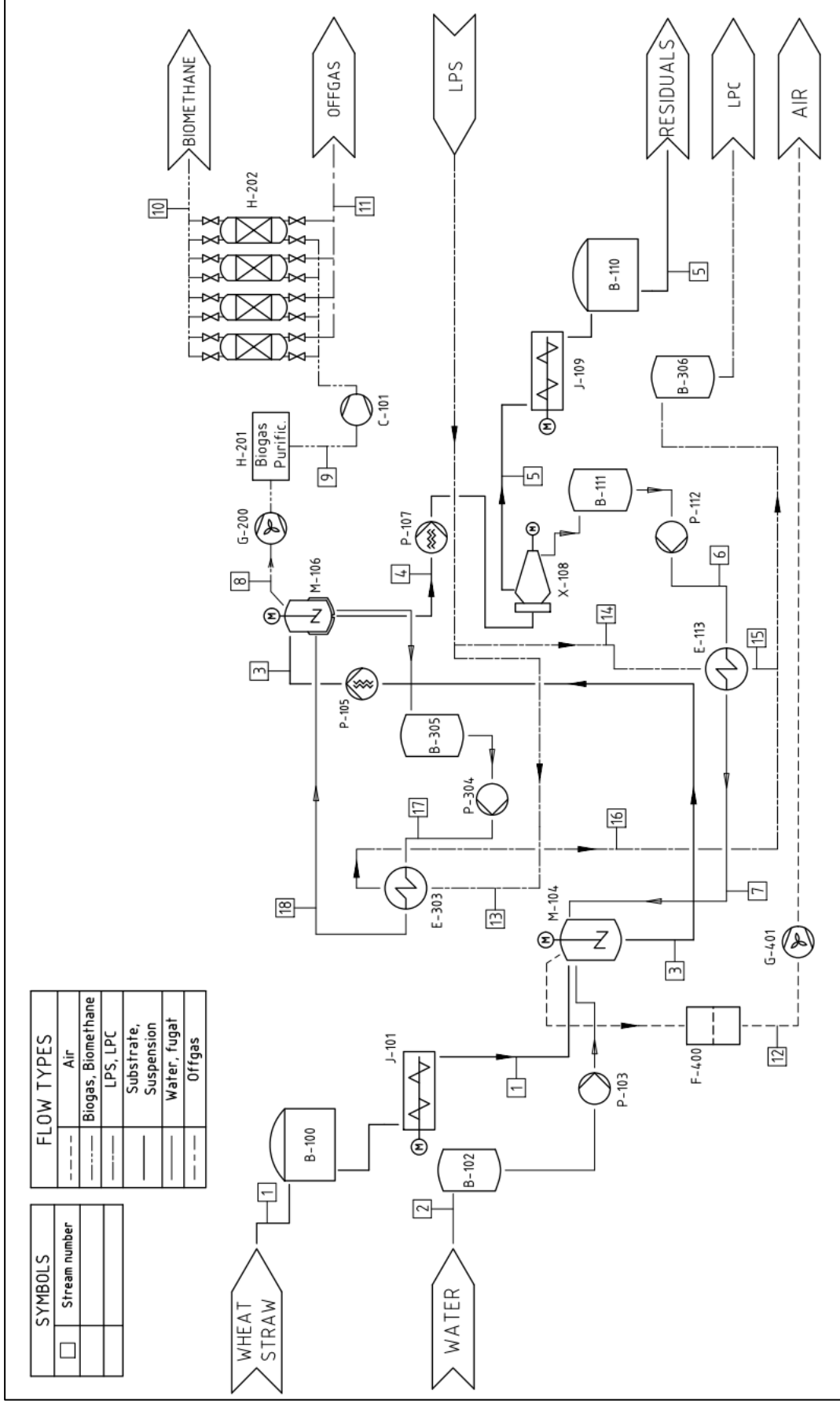

C3. Intensified biogas plant, Flow sheet – intensified pre-treatment

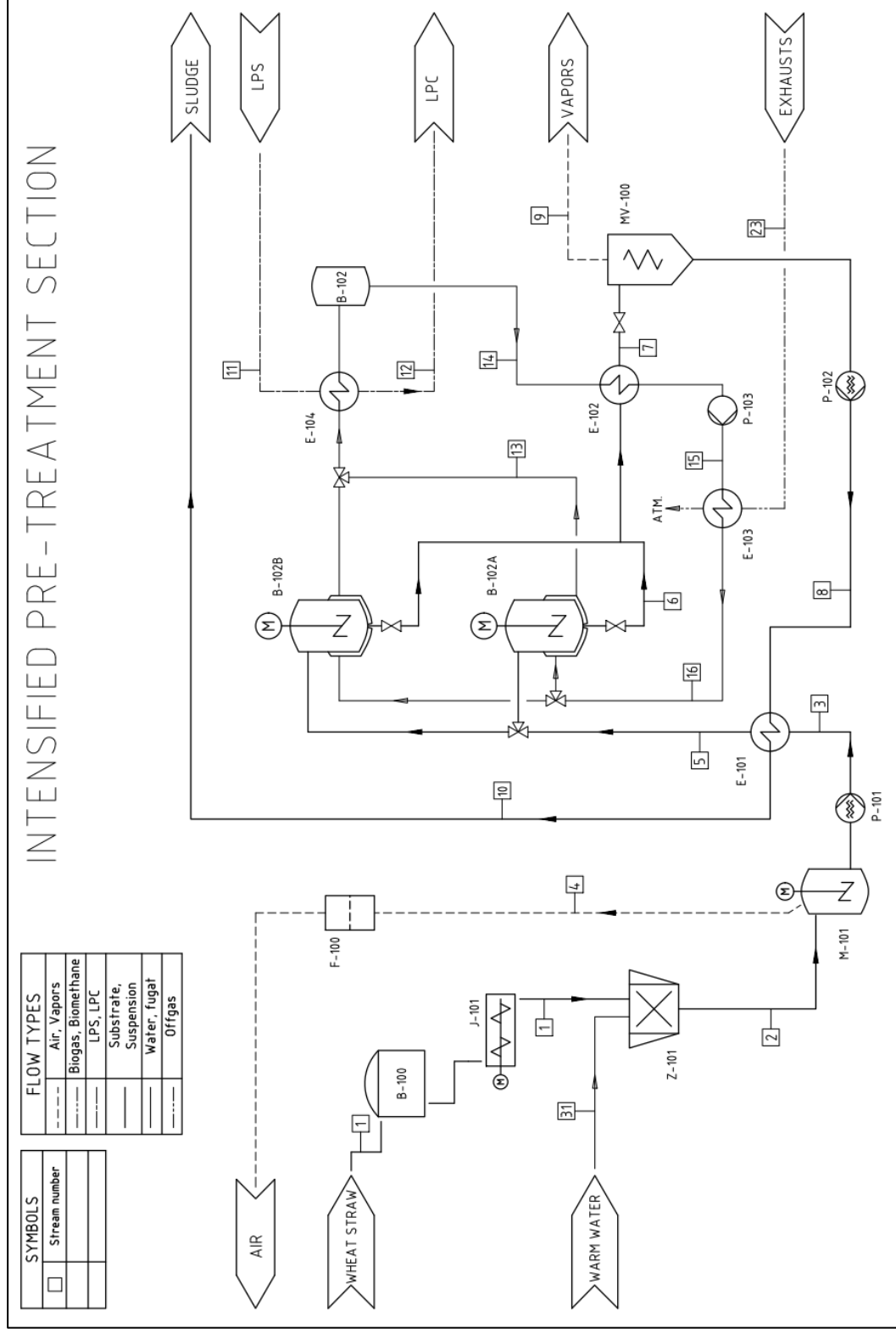

C4. Intensified biogas plant, Flow sheet - biogas production

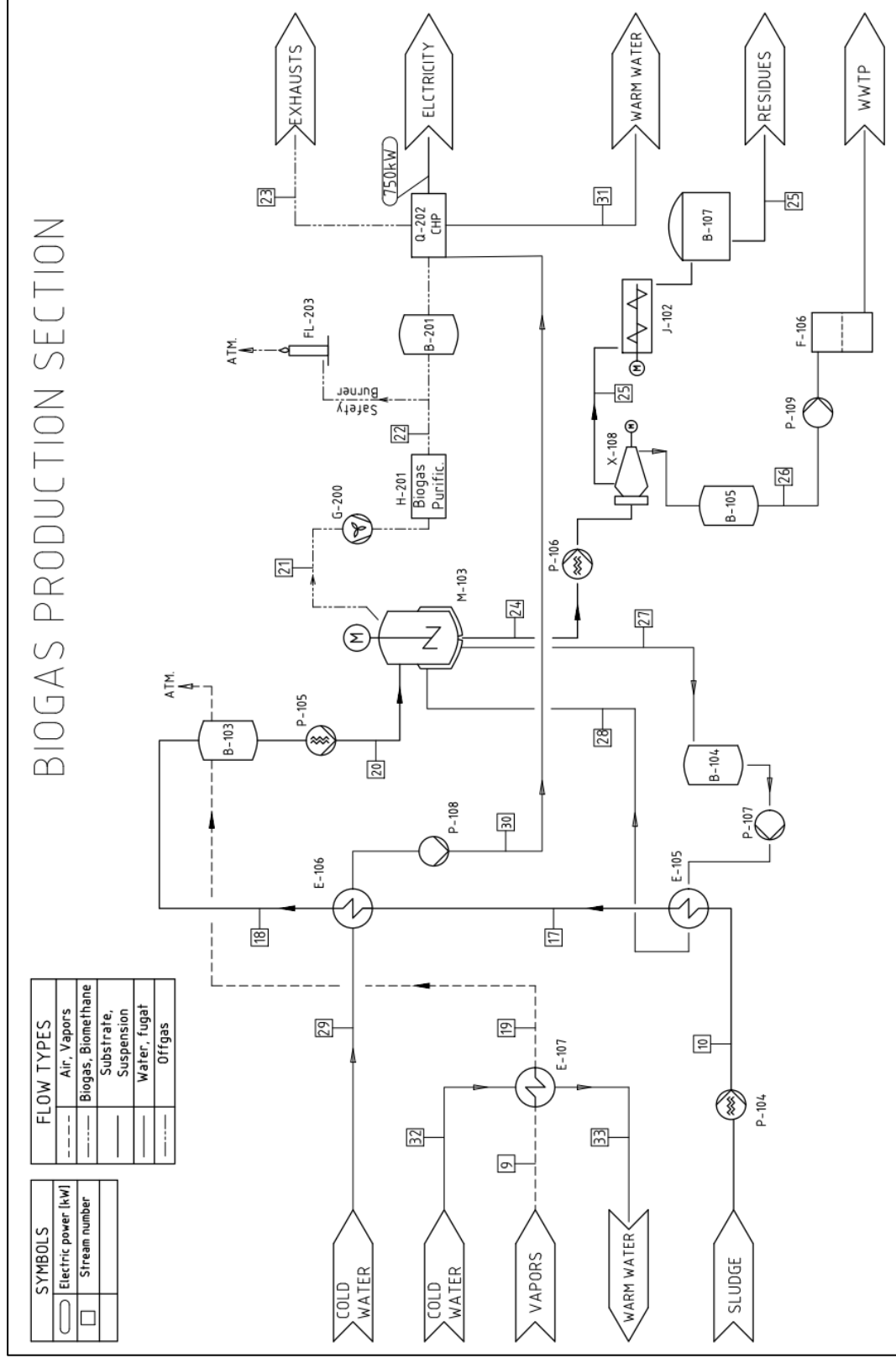

D3. Biogas-fiber biorefinery, Flow sheet – intensified pre-treatment

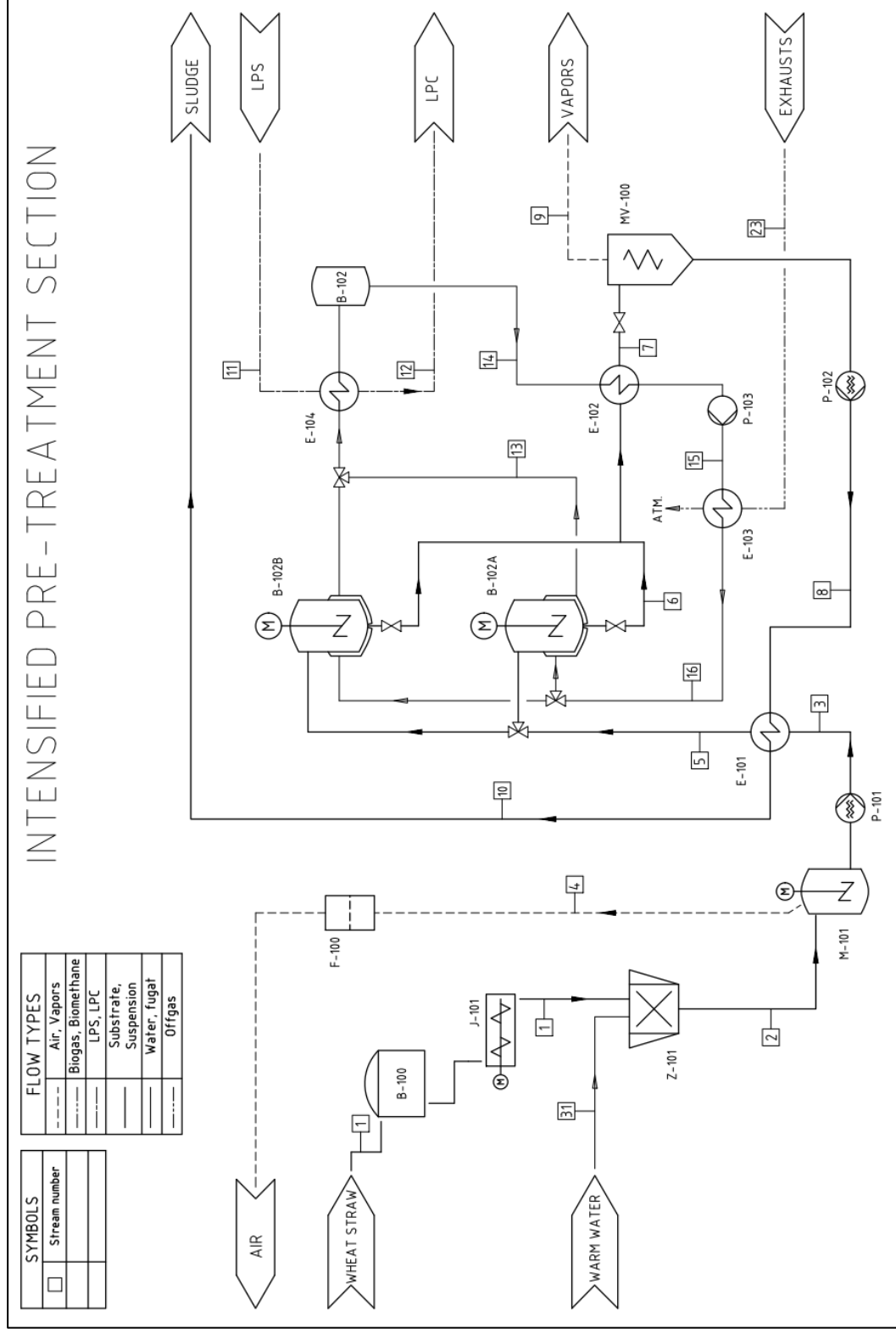

D4. Biogas-fiber biorefinery, Flow sheet – biogas-fiber

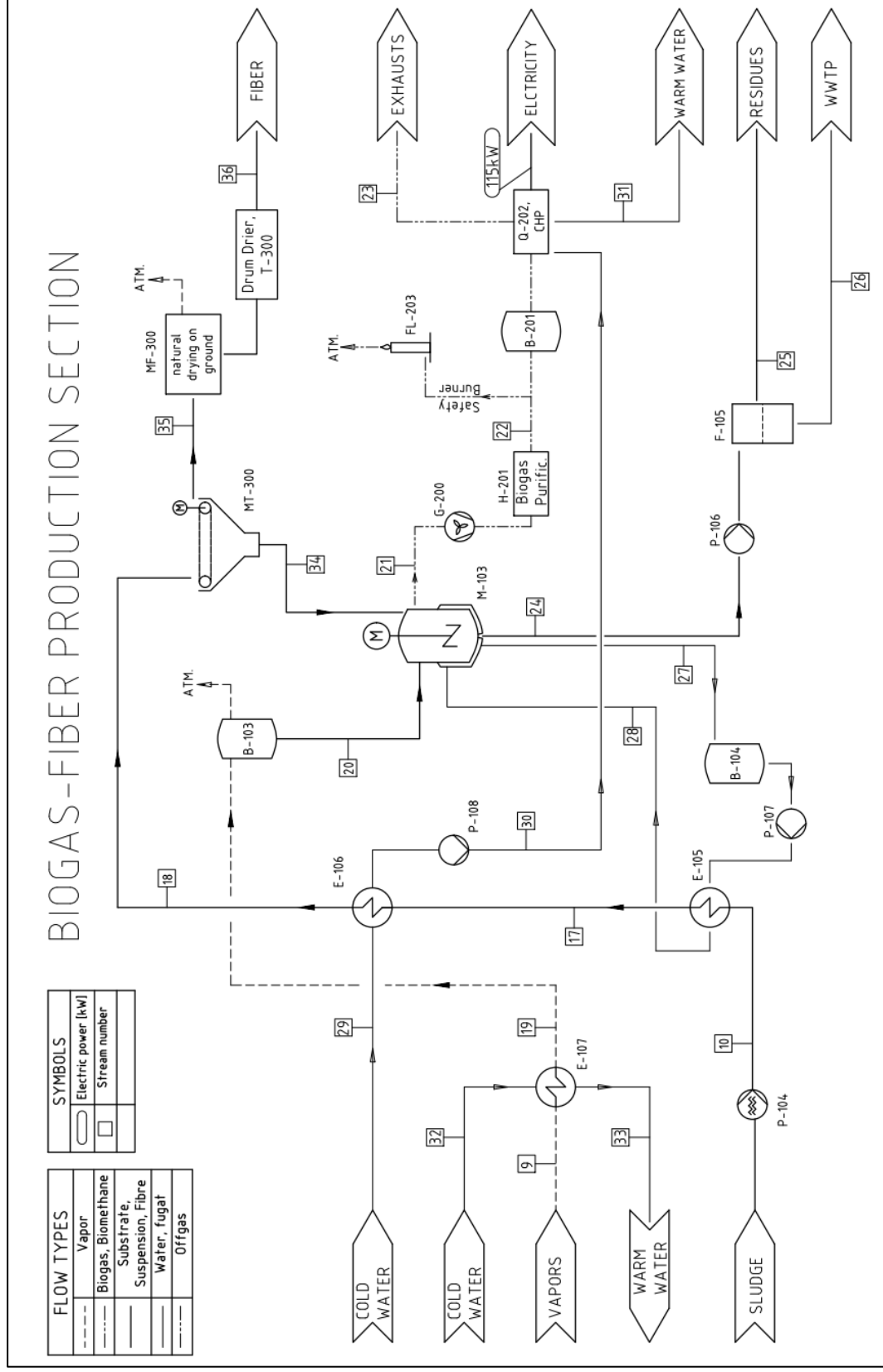

E3. Biogas-algae biorefinery, Flow sheet – biogas production

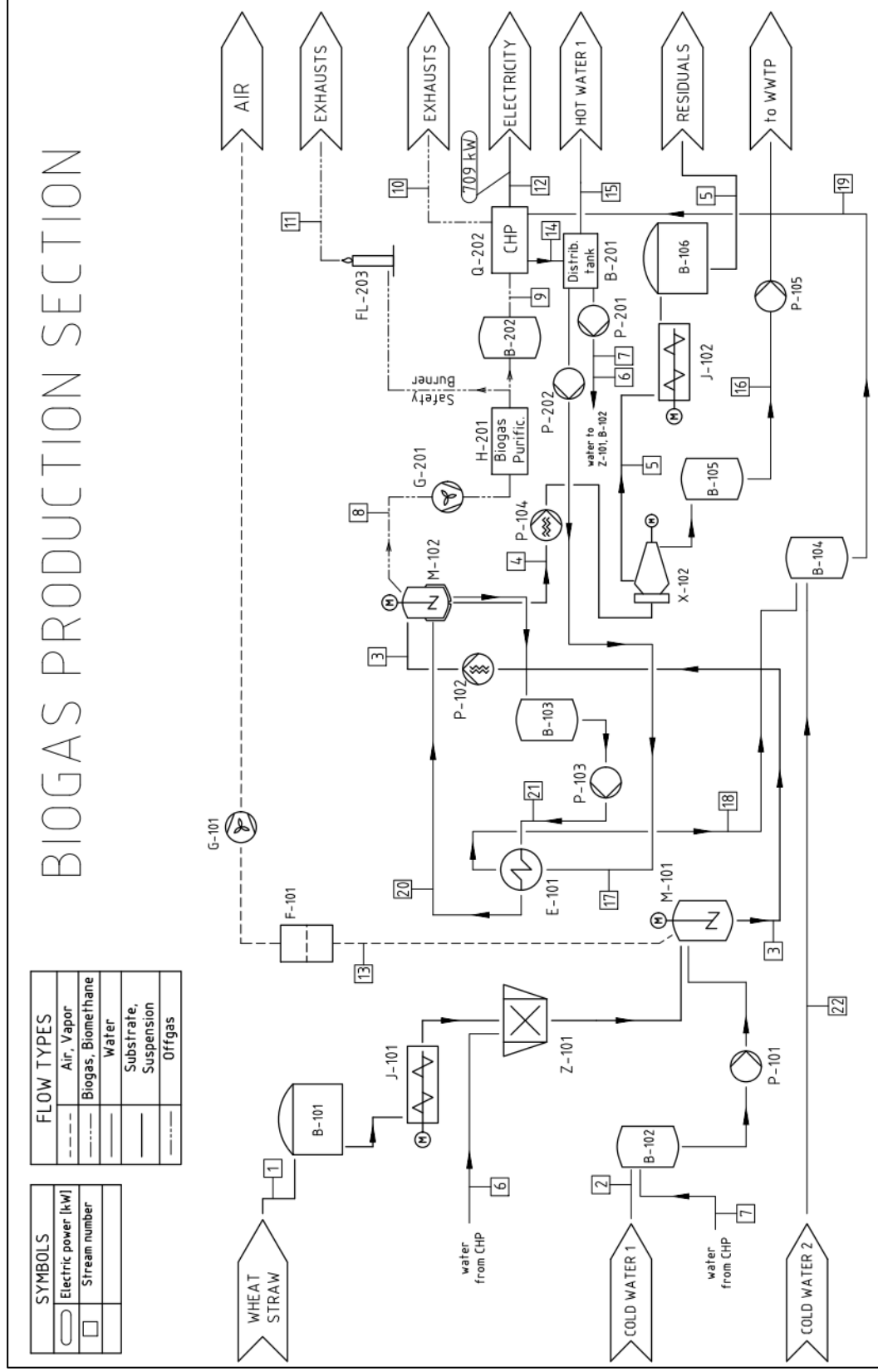



E4. Biogas-algae biorefinery, Flow sheet – algae production

