



# Stave Insertion Tooling Assembly Instruction

Jan Brajer, Martin Janda, Jakub Janoušek

# Box opening





Assy it belongs to  
 Step you need it  
 Fastener dimensions

# Parts list

	Description	QTY.	Box
1	Low Z OC bracket long	2	Bottom
2	Low Z OC bracket short	4	Bottom
3	High Z OC Brackets	6	Bottom
4	Longitudinal Beams	6	Top
5	Low Z Legs	6	Bottom
6	High Z Legs	6	Bottom
7	Central Ring	2	Bottom
8	R arm	2	Top
9	Positioning Arm	1	Top
10	12V PSU	1	Bottom
11	24V PSU	1	Bottom
12	Power Cord	1	Bottom
13	Fasteners Kit	1	Bottom
14	USB to RS485 Dongle and cable	1	Top

Transport box Top compartment

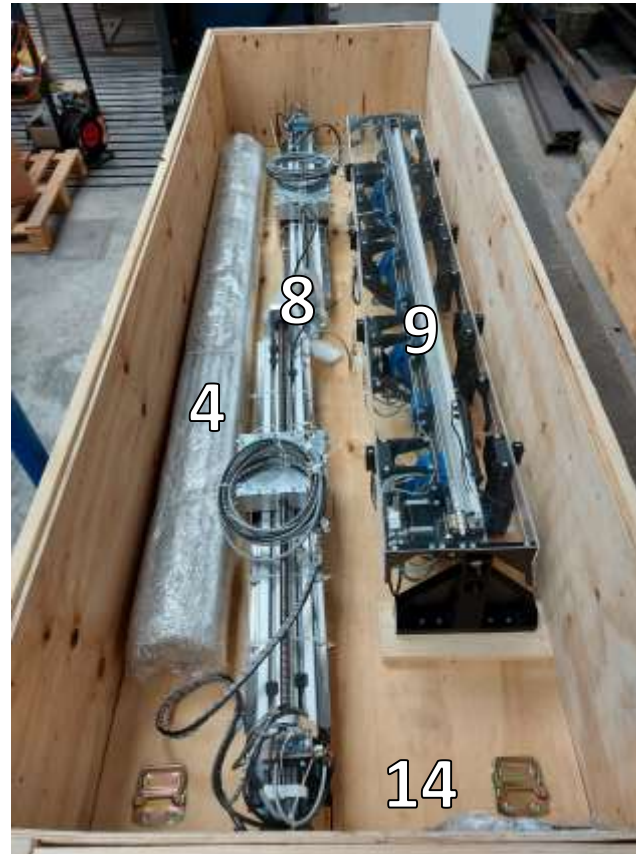

Transport box Bottom compartment

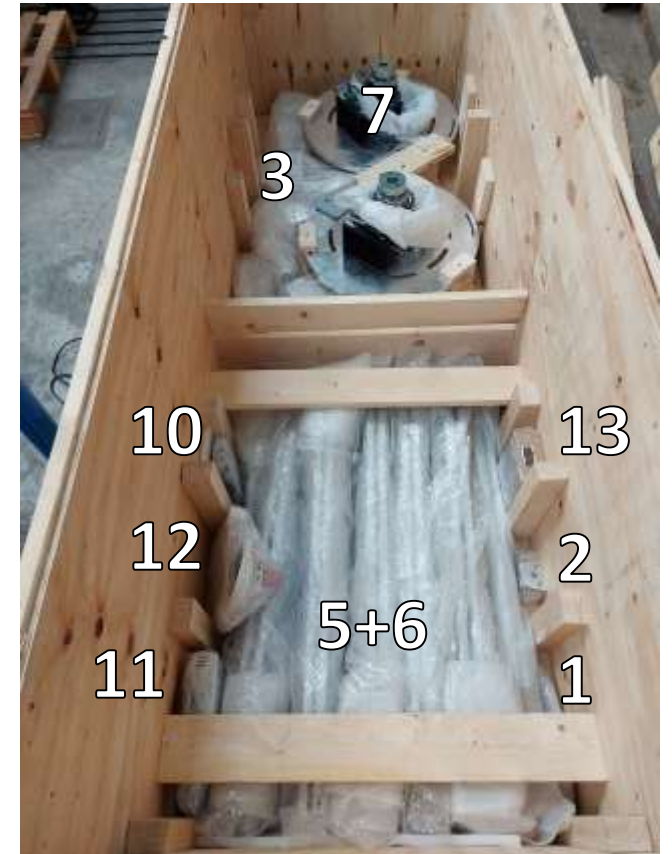

# Step 1

1.1 Attach two long low Z brackets at 12 and 6 o'clock positions using four M8 socket head cap screws.

1.2 Attach two short low Z brackets at 45deg positions using two M8 socket head cap screws.

1.3 Attach 6 high Z brackets using two M8 screws.

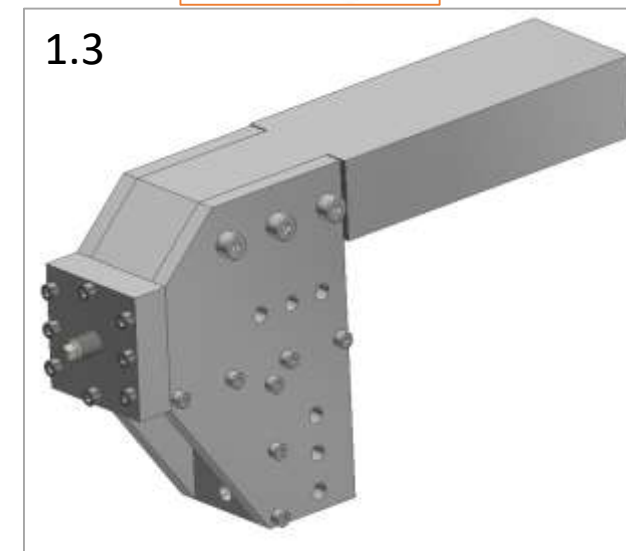

2.1 Remove high Z end brackets front plate with M12 adjustable foot.

2.2 Insert six longitudinal beams.

2.3 Put the front plate back on the high Z end brackets and apply torque on M12 adjustable foot.

2.4 Insert and tighten two M8 screws on each side of the bracket.



## Step 2

2.1

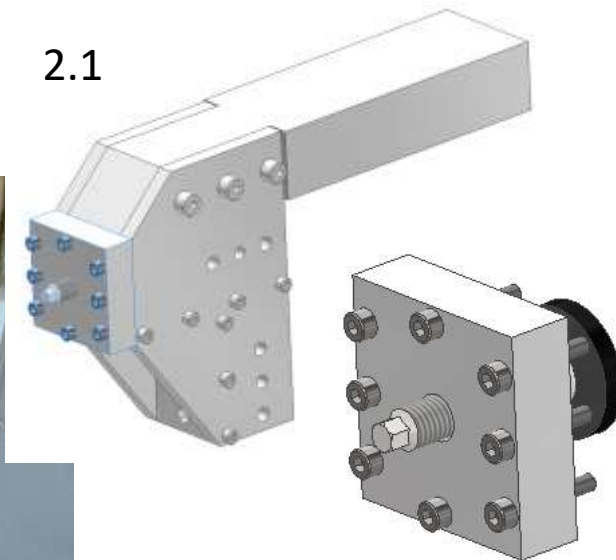

2.4

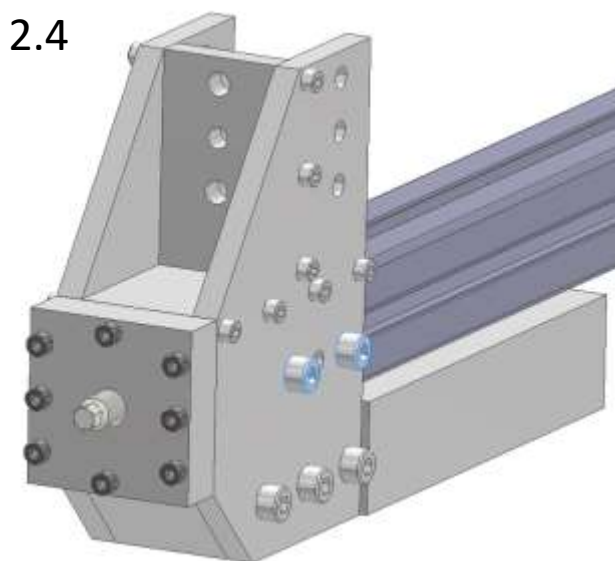

3.1 Put first vertical low Z end leg on the 6 o'clock position longitudinal beam.

3.2 Insert and tighten two M8 screws on each side of leg end bracket.

3.3 Put the central ring with one leg bracket on the vertical leg.

3.4 Insert and **do not tighten** six M8 screws on ring bracket.



## Step 3

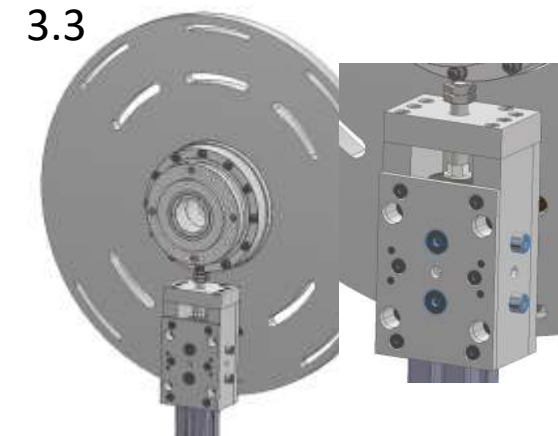
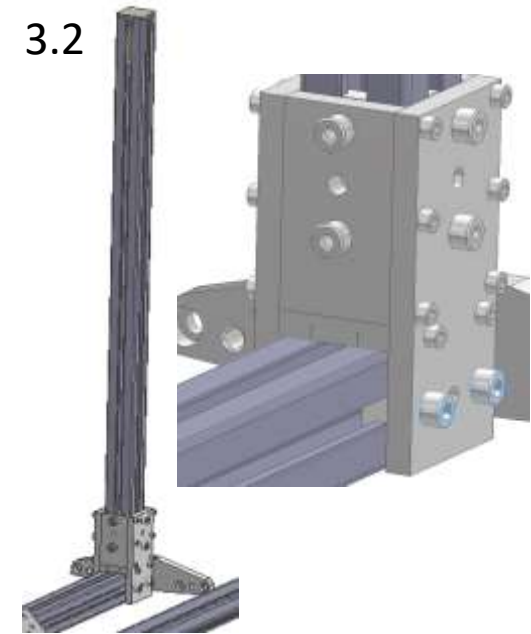

## Step 3

3.5 Set required central ring rotation axis height using adjustable foot.

Distance between leg's brackets is 666.8mm.

3.6 Tighten all M8 screws on central ring bracket.

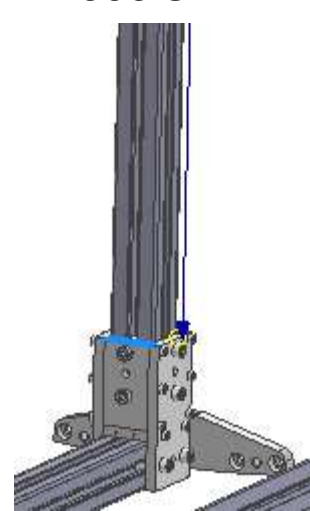
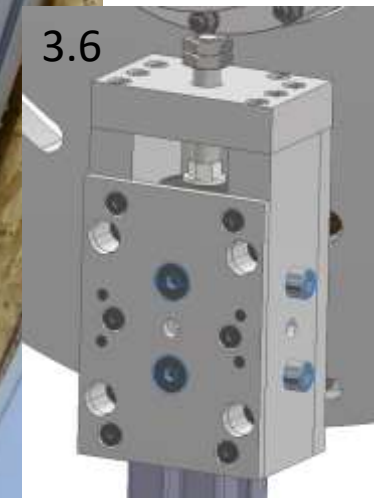
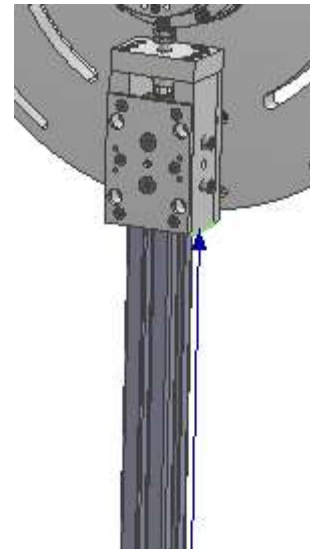
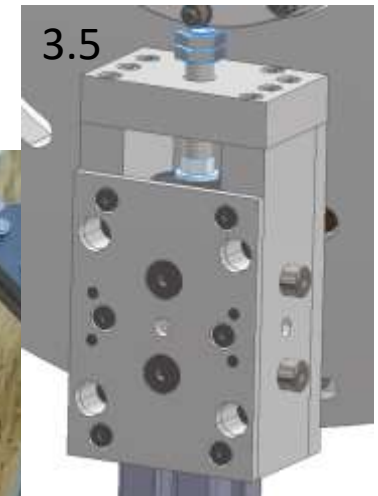

# Step 4

4.1 Attach two top low Z end legs at 45deg.

4.2 tighten four M8 screws at high R end brackets.

4.3 Put ring bracket nut from back side of the central ring and insert four M8 bolts to ring bracket. **Do not fully tighten the bolts.**

4.4 Use adjustable foots to make 6 o'clock leg vertical. (see step 3)

4.5 Tighten all M8 screws on ring brackets.

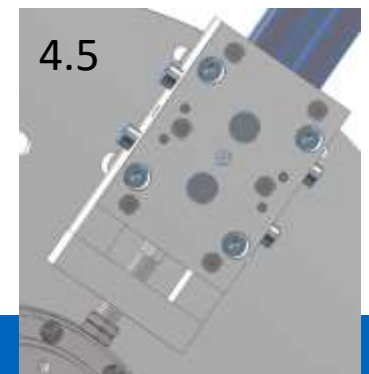
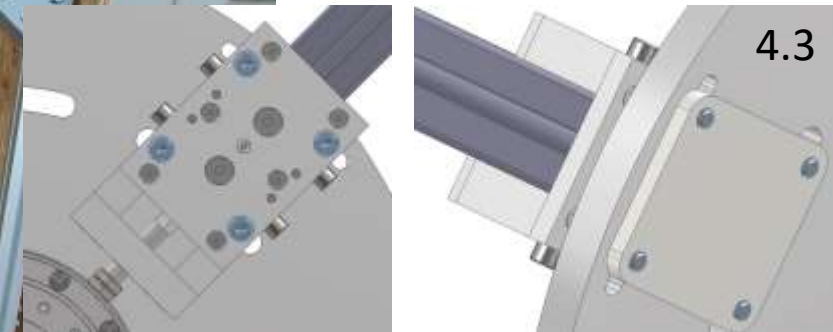
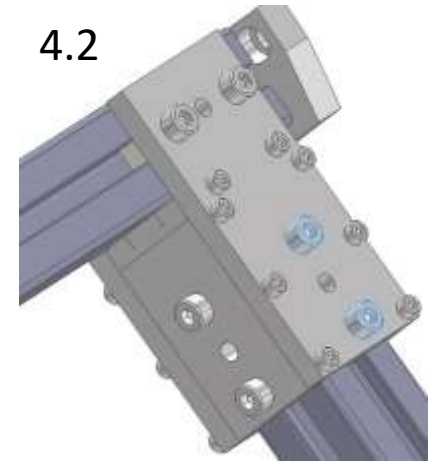



**This step can be skipped and done later.**

5.1 Attach another three legs.



6.1 Attach at least three legs at high Z end. Follow instructions in steps 3 to 5.



## Step 6



7.1 Untighten two M5 socket head cap screws on each side of R-arms side plates. **Only the ones marked with arrows!!**

7.2 Attach R-arm on central ring square plate and secure with middle M8 screw.

7.3 Insert and tighten four M6 shoulder bolts.

7.4 Tighten four M5 screws on R-arm side plates (untightened in step 7.1).

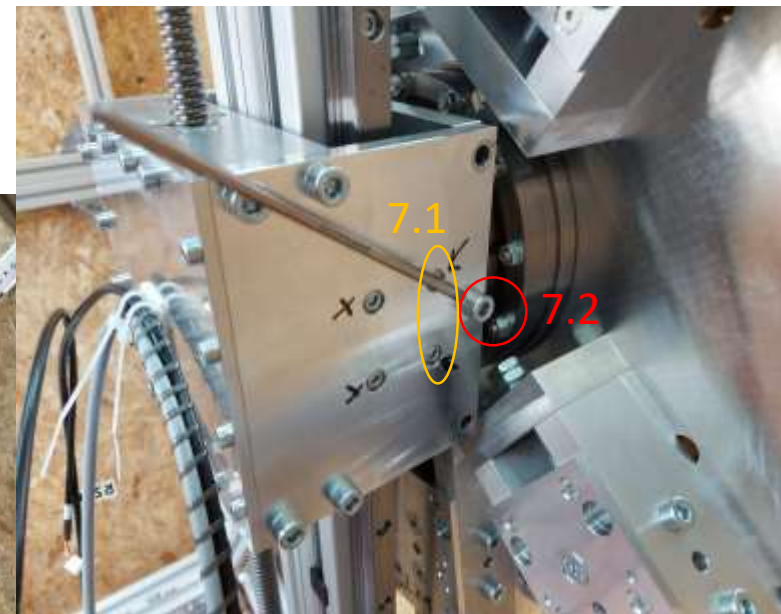

7.5 Connect black cables labelled RS485 to signal converter boards on central ring drive.



## Step 8

8.1 Put the positioning arm on R-arms.

8.2 Secure the arm position with two M8 screws located at the bottom side of the arm.

8.3 Insert and tighten two M12 screws at both sides of the arm.

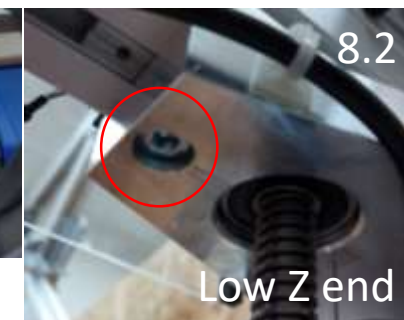

8.4 Connect 12VDC power supply cable to 12VDC distribution board at high Z end.

8.5 Connect black communication cable labelled RS485 to signal converter boards at each arm end.

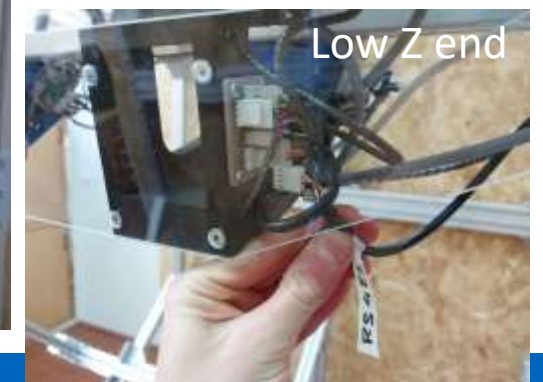
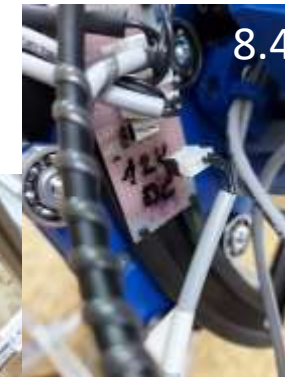
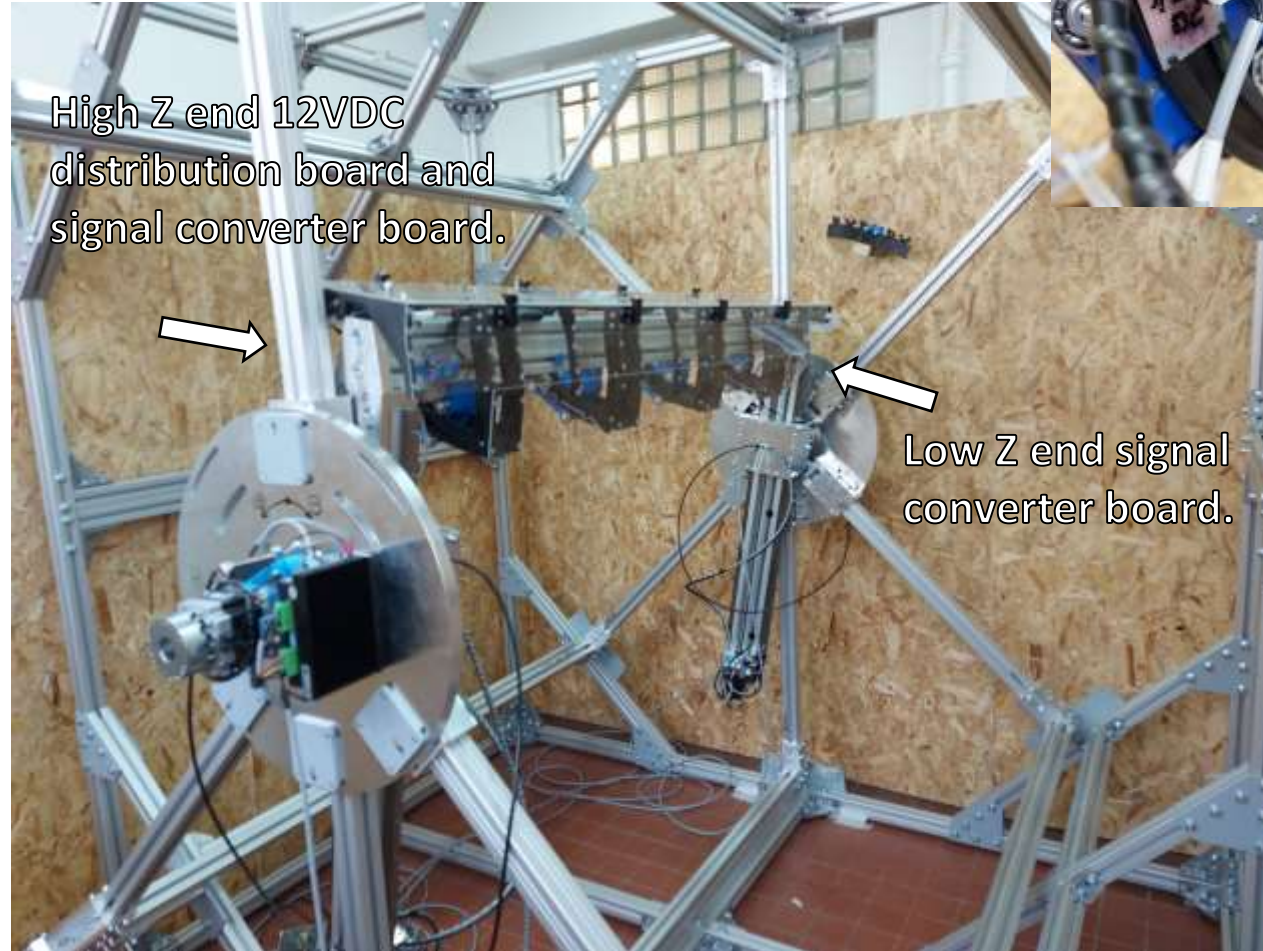

## 10.1 Connect power cables to 12 and 24 VDC power supplies.

- Positioning arm = 12VDC, at least 100W.
- Rotation and R movement = 24VDC for steppers and 12VDC for controllers, at least 400W.

## 10.2 Join grounds on power supplies.

## 10.3 Secure power supplies with total stop red button.

