

Master Thesis



Czech
Technical
University
in Prague

F3

Faculty of Electrical Engineering
Department of Measurement

**Development and implementation of a
system for transmission, processing and
presentation of live results during
orienteering competitions**

Bc. Jan Jurica

Supervisor: Prof. Ing. Jan Holub, Ph.D.
Field of study: Cybernetics and Robotics
May 2022

I. OSOBNÍ A STUDIJNÍ ÚDAJE

Příjmení: **Jurica** Jméno: **Jan** Osobní číslo: **466302**
Fakulta/ústav: **Fakulta elektrotechnická**
Zadávací katedra/ústav: **Katedra měření**
Studijní program: **Kybernetika a robotika**
Studijní obor: **Kybernetika a robotika**

II. ÚDAJE K DIPLOMOVÉ PRÁCI

Název diplomové práce:

Vývoj a implementace systému pro přenos, zpracování a prezentaci živých výsledků během soutěží v orientačním běhu

Název diplomové práce anglicky:

Development and implementation of a system for transmission, processing and presentation of live results during orienteering competitions

Pokyny pro vypracování:

1. Seznamte se současnými řešeními pro přenos, zpracování a prezentaci živých výsledků během závodů v orientačním běhu.
2. S využitím procesoru Atmega2560 sestavte sadu zařízení pro přenos živých výsledků z kontrolních bodů během závodů. Komunikačním kanálem je GPRS nebo jiné vhodné mobilní připojení.
3. Vytvořte aplikaci pro zpracování přenesených dat (výsledků) a jejich prezentaci pro diváky a komentátory závodů.
4. Otestujte vytvořený systém a vyhodnoťte jeho spolehlivost.

Seznam doporučené literatury:

1. Směrnice - Ověřené systémy označování závodních průkazů, <https://www.orientacnibeh.cz/upload/dokumenty/sekce-ob/smernice-razeni-19.pdf>, 2021, [Online; accessed December 13, 2021].
2. Soutěžní řád soutěží sekce orientačního běhu ČSOS v roce, <https://www.orientacnibeh.cz/upload/dokumenty/sekce-ob/sr-ob21.pdf>, 2021, [Online; accessed December 13, 2021].
3. Pravidla orientačního běhu, <https://www.orientacnibeh.cz/upload/dokumenty/sekce-ob/pravidla-ob-2021.pdf>, 2021, [Online; accessed December 13, 2021].
4. Dokumentace k modulu přijímače, https://www.sportident.com/documents/si-radio/SRR-Kit/SPORTident_SRR-Dongle.pdf

Jméno a pracoviště vedoucí(ho) diplomové práce:

prof. Ing. Jan Holub, Ph.D. katedra měření FEL

Jméno a pracoviště druhé(ho) vedoucí(ho) nebo konzultanta(ky) diplomové práce:

Datum zadání diplomové práce: **14.12.2021**

Termín odevzdání diplomové práce: _____

Platnost zadání diplomové práce:

do konce letního semestru 2022/2023

prof. Ing. Jan Holub, Ph.D.
podpis vedoucí(ho) práce

podpis vedoucí(ho) ústavu/katedry

prof. Mgr. Petr Páta, Ph.D.
podpis děkana(ky)

III. PŘEVZETÍ ZADÁNÍ

Diplomant bere na vědomí, že je povinen vypracovat diplomovou práci samostatně, bez cizí pomoci, s výjimkou poskytnutých konzultací. Seznam použité literatury, jiných pramenů a jmen konzultantů je třeba uvést v diplomové práci.

Datum převzetí zadání

Podpis studenta

Acknowledgements

I would like to thank Prof. Ing. Jan Holub, Ph.D., for professional guidance during the elaboration of the master thesis.

Declaration

I declare that the presented work was developed independently and that I have listed all sources of information used within it in accordance with the methodical instructions for observing the ethical principles in the preparation of university theses.

Prague, May 15, 2022

Prohlašuji, že jsem předloženou práci vypracoval samostatně a že jsem uvedl veškeré použité informační zdroje v souladu s Metodickým pokynem o dodržování etických principů při přípravě vysokoškolských závěrečných prací.

V Praze, 15. května 2022

Abstract

The master thesis describes the development, implementation and real deployment of a system for the transmission of live results during orienteering competitions. The system consists of hardware devices located at control points in terrain that transmit records of passing competitors to a remote server where these records are then processed. The system was used in a total of 18 orienteering competitions, including three national championships, one of which was also broadcast live on television.

Keywords: orienteering, live results, radio transmission, mobile network, 3D print, ATmega2560, RP2040

Supervisor: Prof. Ing. Jan Holub, Ph.D.

Abstrakt

Tato diplomová práce popisuje vývoj, implementaci a reálné nasazení systému pro přenos živých výsledků během závodů v orientačním běhu. Systém je složen z hardwarových zařízení umístěných na kontrolních bodech závodů, které přenášejí záznamy probíhajících závodníků na vzdálený server, kde jsou následně tyto záznamy zpracovány. Systém byl celkem použit na 18 závodech v orientačním běhu včetně třech národních mistrovství, z nichž jedno bylo navíc živě vysíláno v televizi.

Klíčová slova: orientační běh, živé výsledky, radiový přenos, mobilní síť, 3D tisk, ATmega2560, RP2040

Překlad názvu: Vývoj a implementace systému pro přenos, zpracování a prezentaci živých výsledků během soutěží v orientačním běhu

Contents

1 Introduction	1	4 System deployment and measurements	31
2 Orienteering and systems used to measure and evaluate competitions	3	4.1 Devices used in the competitions	31
2.1 Orienteering	3	4.2 Competitions where the system was used	33
2.2 Timekeeping of competitions	5	4.3 System reliability	34
2.3 Radio controls	7	4.4 Punch record traffic analysis	37
2.4 Software for organizing orienteering competitions	8	4.5 Battery voltage and run time	41
3 Developed live results transmission system	11	5 Discussion	47
3.1 Hardware	11	5.1 Future work	48
3.1.1 Device based on ATmega2560 MCU	13	6 Conclusion	49
3.1.2 Device based on the RP2040 MCU	21	A Bibliography	51
3.2 Software	25	B Content of enclosed CD	55
3.2.1 Database	25		
3.2.2 Backend	27		
3.2.3 Frontend	28		

Figures

2.1 A competitor tagging a control point during an orienteering race. Photo by M. Jonáš [Jon22]	4	3.7 PCB design	17
2.2 Example of a sprint orienteering map with a scale of 1:4000. Source:[Par20]	4	3.8 Top side of the finished PCB . . .	18
2.3 Comparison of SIAC (left) and SI-Card9 (right).	6	3.9 The 3D model of the device	18
2.4 SPORTident stations - standard (left) and equipped for radio control point (right).	6	3.10 Unwrapped 3D model of the device	19
2.5 SPORTident SRR dongle	7	3.11 The device attached in the holder at a control point	19
3.1 Graphic illustration of the developed live results transmission system. The graphic was designed using resources from [Com22].	12	3.12 Raspberry Pi Pico based device schematics	21
3.2 Mega 2560 Pro based device schematics	13	3.13 Raspberry Pi Pico board	22
3.3 Mega 2560 Pro board	14	3.14 PCB design	23
3.4 GSM module with SIM800L	15	3.15 Top side of the finished PCB . .	23
3.5 The inner piece of SPORTident SRR dongle	16	3.16 The 3D model of the device . . .	24
3.6 The charger module with TP4056 (left) and the step-up module with SX1308 and trimmer (right).	17	3.17 Unwrapped 3D model of the device	24
		3.18 Database structure	26
		3.19 Device status monitor	28
		3.20 Punch record traffic monitor . .	29
		3.21 Page with competitions registered in the system	30

4.1 Built devices that were used in competitions.....	32
4.2 BB-1 device mounted on a separate stand during the Prague Easter competition. Photo by V. Illner [Ill22]	32
4.3 BB-2 device mounted on the same stand with the control station during the Czech Championship in Sprint Relay 2022. Photo by A. Švarc [Šv22]	33
4.4 The system was used in the ČT Sport live broadcast of the Czech Championship in Sprint Relay. ...	34
4.5 BB-3 device punch records traffic and signal strength during competition number 2.	38
4.6 BB-3 device punch records traffic and signal strength during competition number 16.	39
4.7 BB-3 device punch record traffic and signal strength during competition number 8.	40
4.8 Punch record traffic of all devices used in competition number 17....	41
4.9 The battery voltage of all devices used during competition number 7.	42
4.10 The BB-5 placed on the stand of the finish control point of the Czech Championship in Sprint 2022. Photo by J. Čech [Če22]	45

Tables

4.1 List of competitions where the system was used	34
4.2 The number of transmitted punch records (TR), actual punch records (AR) and computed device reliability (DR) in percentage of BB-1, BB-2 and BB-3 devices.....	35
4.3 The number of transmitted punch records (TR), actual punch records (AR) and computed device reliability (DR) in the percentage of BB-4, BB-5 and BB-6 devices.....	36
4.4 The number of transmitted punch records (TR), actual punch records (AR) and computed system reliability (SR) in percentage at each competition.	37
4.5 Estimated maximum run time of selected devices.....	43
4.6 Battery voltage, average signal strength, run time and voltage discharge speed of the BB-1 device	43
4.7 Battery voltage, average signal strength, run time and voltage discharge speed of the BB-3 device	44
4.8 Battery voltage, average signal strength, run time and voltage discharge speed of the BB-4 device	44

4.9 Battery voltage, average signal strength and run time of the BB-2 device 44

4.10 Battery voltage, average signal strength and run time of the BB-5 device 44

4.11 Battery voltage, average signal strength and run time of the BB-6 device 45





Chapter 1

Introduction

Modern technologies are constantly evolving and expanding into new fields of interest. The addition of new modern technologies is also taking place in the field of sports. The topic of this master thesis focuses on the modern technologies used in orienteering sports. Orienteering is a sport that I have been doing for more than 13 years. Modern technologies have played a role in orienteering sports since the 1990s, where they are used primarily to measure time and check the completion of a track. Orienteering has become a more popular and respected sport in the last two decades, which has also increased the demand for competitions. The trend in recent years has been to make orienteering more attractive to spectators and there are several ways to do it. One solution is to have a GPS device attached to the back of each competitor, which transmits his current position so that spectators can follow him live on the track map. However, this solution is very hardware intensive. The second solution is to place devices at some control points that transfer split times of the competitors as they pass them.

The goal of this thesis is to develop a new system for the transmission of split times from control points on the track and their presentation during orienteering competitions. Great emphasis was placed on the simplicity of system deployment and its overall price. The result of this thesis is a system that is currently used in various orienteering competitions, including national championships.

Chapter 2

Orienteering and systems used to measure and evaluate competitions

2.1 Orienteering

Orienteering is a sport in which competitors must navigate through unknown terrain equipped only with a special orienteering map and a compass. The goal is to find all control points marked on the map in a predetermined order and to get to the last control point in the shortest time possible. The actual control point placed in the terrain consists of a flag stand and a control station which each competitor must tag with an RFID card. This system is described in more detail in Section 2.2. Figure 2.1 shows an example of a competitor tagging a control point during a race.

International Orienteering Federation (hereafter IOF [Fed20]) defines four official orienteering disciplines. The disciplines are orienteering, also known as foot orienteering, mountain bike orienteering (shortly MTBO), ski orienteering (shortly SkiO) and trail orienteering (shortly TrailO). Disciplines are divided according to the way competitors move through the terrain, as the names suggest.

The most important thing a competitor carries during a race is the map. Orienteering maps have specific map key. The map key changes based on at what scale the area is mapped. Larger areas, mostly forests, are mapped at smaller scales of 1:10000 or 1:15000 using a different map key than maps of



Figure 2.1: A competitor tagging a control point during an orienteering race. Photo by M. Jonáš [Jon22]

smaller areas, mostly parts of cities, which are mapped at a scale of 1:4000. The scale of a map usually corresponds to the length of a course where smaller scaled maps are used for long and middle distance competitions and bigger scaled maps for short-distance competitions also called sprints. Figure 2.2 shows an example of a sprint orienteering map with a scale of 1:4000.

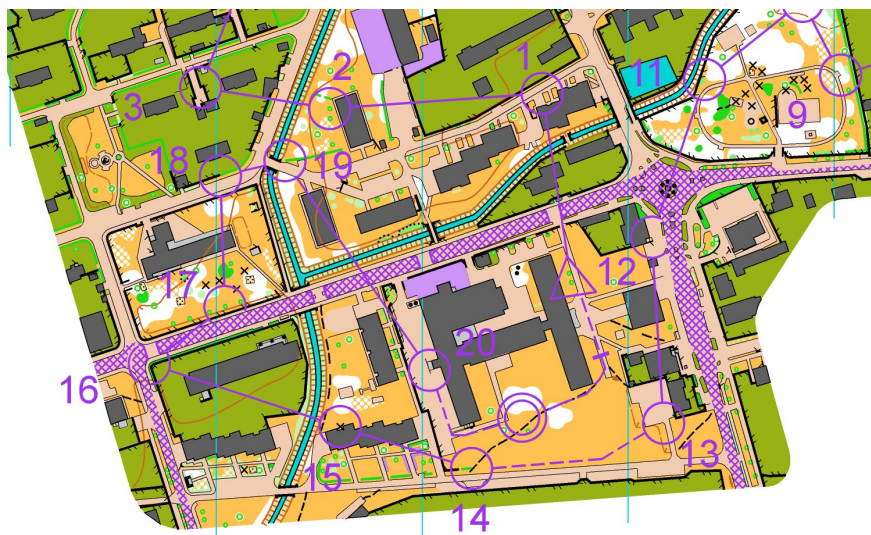

Figure 2.2: Example of a sprint orienteering map with a scale of 1:4000. Source:[Par20]

2.2 Timekeeping of competitions

The timekeeping of the orienteering competitions is provided by a timekeeping and identification systems, called punching systems. Competitors carry a punching card that they are required to punch at all control points on the course. The card is evaluated after the race. The directive [Če20b] of the Czech Orienteering Association (hereafter CSOS) allows three different punching systems to be used in orienteering competitions in the Czech Republic. One of them is the SPORTident system, which is currently the only punching system used in competitions in the Czech Republic and also the most used punching system in the orienteering world. SPORTident GmbH [SPO20] is a technological company from Arnstadt, Germany, which has been developing its punching system since 1996. The SPORTident system consists of two types of electronic devices (cards and stations) which use two key technologies - Radio Frequency Identification (hereafter RFID) and Short Range Radio (hereafter SRR).

The SPORTident system currently utilizes two types of cards - passive and active. Passive cards (hereafter SI-Cards) consist of a small passive RFID tag. Competitors must insert the SI-Card directly into the hole of a station placed at the control point to exchange all necessary information between the card and the station. The exchange data are called punch records which consist of 20 bytes. Each punch record carries information such as time of punch, control point number, SI-Card number and more. The newest SPORTident card is SI-Card10, which can store 128 punch records and data exchange time with a station is 60 ms. The SPORTident active cards (hereafter SIACs) extend the passive cards of the SRR technology. SIACs have an integrated SRR receiver and transmitter using a radio band frequency of 2.4 GHz. This allows contactless punching (without the need to insert SIAC into the station) of the control point station. The fact that SIAC is an active card has led to the need for a battery, so it is more robust than passive SI-Cards. After two years of use, it is also necessary to send SIAC back to SPORTident due to the need to replace the battery. The distance for contactless data exchange is set to 30 cm according to the international rules of orienteering defined by the IOF. SIAC can store 128 punch records and the contactless data exchange time is 50 ms. The advantage of contactless punching is that a competitor with SIAC can be up to 1.2 seconds faster than a competitor with a passive SI-Card according to the study conducted by the O-News Web portal [PB20]. Figure 2.3 shows a comparison of SIAC and SI-Card.

The second type of devices used in the SPORTident system are called stations. The stations are placed on stands at control points. SPORTident stations are active devices equipped with a real-time clock, RFID reader,



Figure 2.3: Comparison of SIAC (left) and SI-Card9 (right).

SRR transmitter, and backup memory. The real-time clock system has a time resolution of approximately 4 ms. The stations operate in two modes - direct and contactless punching. SPORTident station in contactless mode sends out punch record data as a beacon. The SIAC that is passing in active mode is able to receive the data and store it in the memory. Competitors with passive cards can still punch in the direct (contact) mode, whether the stations are in contactless mode. Today, most competitions are set in contactless mode, but there is still an option to set a competition or training in direct mode, which saves the battery of the stations and SIACs. The stations are equipped with a lithium battery which is non-rechargeable. However, the power efficiency of the stations allows users to operate them safely for more than three years before the need to replace the battery or buy a new station. All stations can be freely reprogrammed and set for the specific purposes of any orienteering competition. The settings usually include adjusting the internal clock, changing the control point number or setting the working mode of the station. Figure 2.4 shows two different SPORTident stations.



Figure 2.4: SPORTident stations - standard (left) and equipped for radio control point (right).

2.3 Radio controls

Orienteering is not a very attractive sport from an audience's point of view as competitors are most of the time during a race in a forest or a city where nobody can see them. Radio controls are control points on a track from which punch records (split times) are transmitted to the spectators. Radio controls play an important role in increasing the appeal of orienteering sports. Radio controls can be placed on multiple control points depending on the type of race and the audience can watch the progress of competitors by checking the split times on each radio control. A special SPORTident station equipped with an additional SRR transmitter must be placed at the radio control. The so-called SRR station is visually similar to a standard SPORTident station, which is shown in Figure 2.4. The process of punching the radio control is the same from a competitor's point of view as punching a standard control point; only the data transmission is different. The SRR station transmits the punch data with additional information that tells the SIAC to send the last punch record received from the station. In the case of direct punch with passive SI-Card, the SRR station transmits the last punch record for the SI-Card because passive SI-Card is not equipped with the SRR transmitter. The transmitted punch records are received by the SRR receivers provided by SPORTident in the form of USB keys (called SRR dongles) shown in Figure 2.5. SPORTident SRR uses two radio channels called BLUE and RED to achieve more robust data transmission and low data loss. The punch record transmitters (the SIACs or the SRR stations) transmit simultaneously in both mentioned channels, but the SRR receivers always operate on one channel only. The SRR channel of the SRR dongle can be freely reconfigured according to the user's needs. The distance of the SRR transmitter and the SRR receiver should be up to 6 metres which allows to place any device with the SRR receiver further from the control point.



Figure 2.5: SPORTident SRR dongle

Chapter 3

Developed live results transmission system

This chapter describes a new live results transmission system developed within this thesis. The system is a combination of hardware described in Section 3.1 and software described in Section 3.2.

The principle of the system is graphically illustrated in Figure 3.1. The system is based on hardware devices and the system server. The hardware devices have a SIM card and are connected to a local cellular network. The SIM card can be replaced depending on the availability of the individual mobile network providers. The hardware devices are also equipped with the SRR receiver, which collects all punch records coming from any SRR station and SIAC nearby. The received punch records are sent to the system server directly from each hardware unit using the mobile network. The punch records are sorted by competition and stored in a database. The last step is that the stored punch records are downloaded to orienteering software using integration in the system's Application Programming Interface (hereafter API). The server application also allows users to monitor the status of individual hardware units and the overall traffic of incoming punch records.

3.1 Hardware

Two types of hardware devices were developed within this thesis. The first device is based on the Atmega2560 microcontroller (hereafter the MCU). Devices with Atmega2560 have been used for live results transmissions since

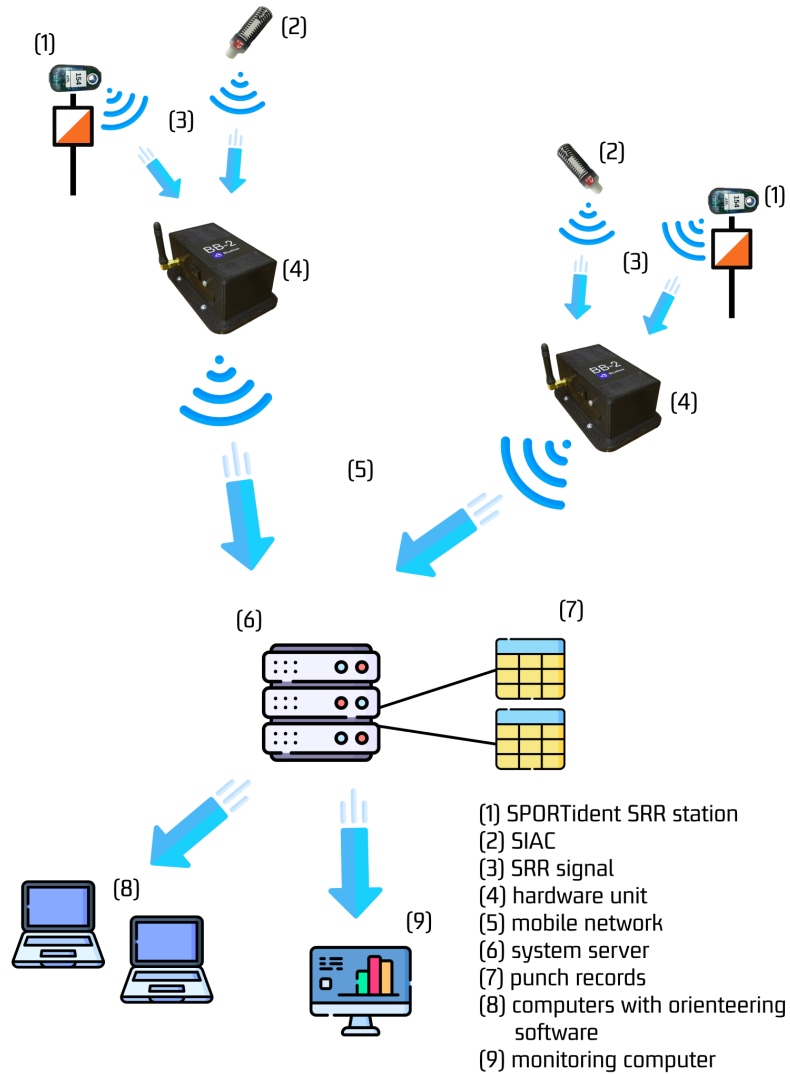

Figure 3.1: Graphic illustration of the developed live results transmission system. The graphic was designed using resources from [Com22].

September 2020. The newer device based on the RP2040 MCU was developed in spring 2022. In addition to electronics, the design of both devices also includes a box casing printed on a 3D printer. The hardware devices developed within this thesis are described in more detail in the following sections.

3.1.1 Device based on ATmega2560 MCU

The schematics of the device based on ATmega2560 are shown in Figure 3.2.

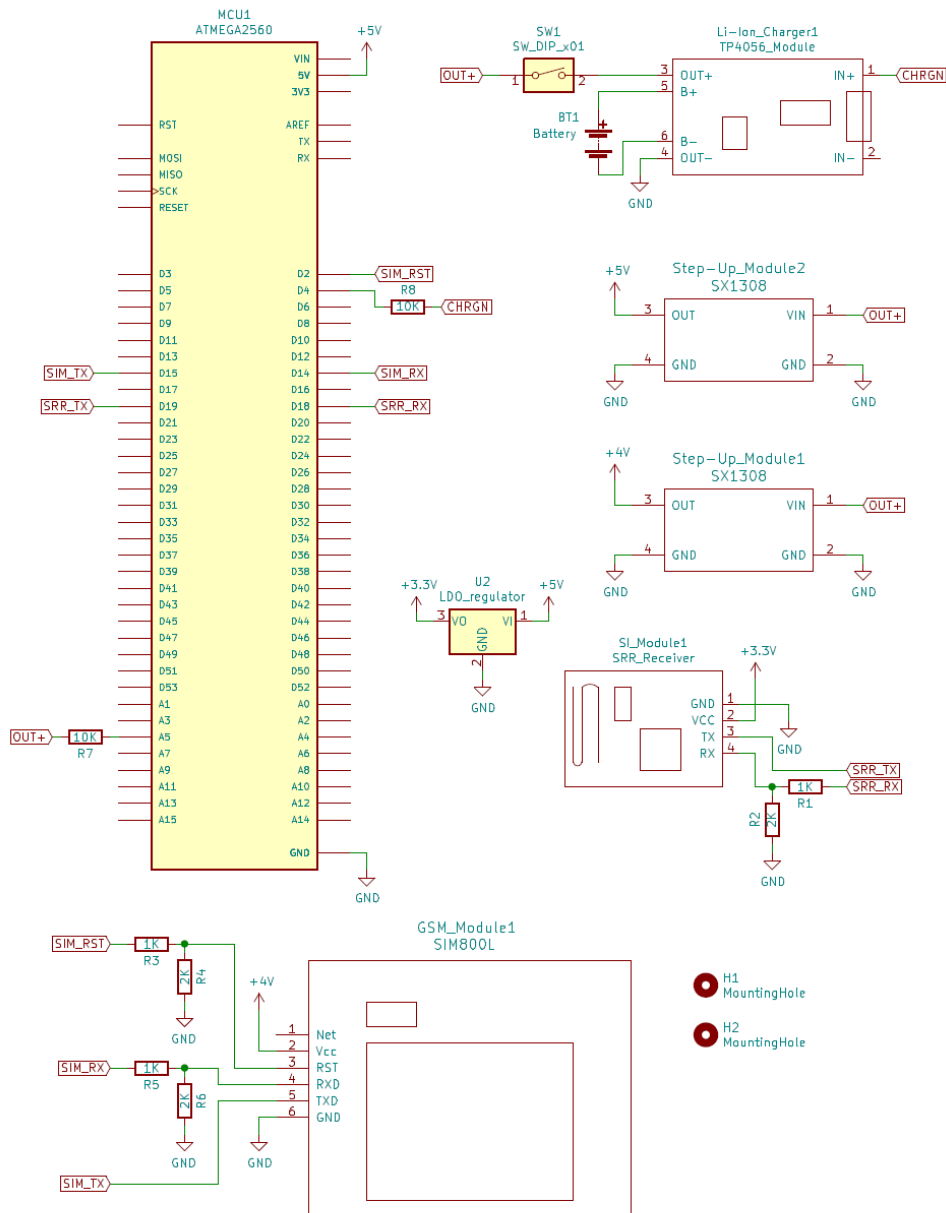

Figure 3.2: Mega 2560 Pro based device schematics

■ Control unit

The control unit of the device is the Mega 2560 Pro board (Figure 3.3) which is a smaller clone version of the well-known Arduino Mega2560 board. The Arduino platform was chosen due to its large user base. The Mega 2560 Pro board is based on the ATmega2560 MCU [Mic14] which is an 8-bit microprocessor with an operating voltage of 5V, 8 KB of static RAM and 256 KB of flash memory. The ATmega2560 has four universal asynchronous receivers/transmitters (hereafter UART). Multiple UARTs allow the device to continuously receive data from the SRR receiver while transmitting the data over the cellular network. The advantage of using the Mega 2560 Pro board is also that it has relatively small dimensions and is cheaper than the original Arduino Mega2560 board.

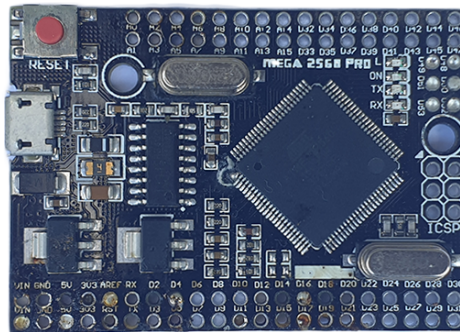

Figure 3.3: Mega 2560 Pro board

■ GSM module

The GSM module shown in Figure 3.4 allows the device to connect to a local mobile network. The GSM module is equipped with the SIM800L microchip [Sim20] produced by SimCom. The SIM800L works on a cellular GSM network at a frequency of 850, 900, 1800 or 1900 MHz. It is able to make and receive calls, SMS, and connect to the Internet using General Packet Radio Service (hereafter GPRS). SIM800L supports a power supply from 3.4 V to 4.4 V, while the recommended operating voltage is 4 V. A sufficient power supply is a key to the proper function of SIM800L. Current consumption is 18 mA in stand-by mode and 453 mA in GPRS mode according to the datasheet [Sim20]. However, the power supply must be able to provide 2 A of current surge during a transmission burst. The power supply of the device is described in more detail in Section 3.1.1. The correct voltage during transmission bursts is also ensured by a ceramic 1000 μ F capacitor placed at the power supply

input of the GSM module, as shown in Figure 3.4. The GSM module is equipped with a micro-SIM socket on the bottom side. An external GSM antenna is connected to the module using the u.fl connector in the top left corner of the module. The GSM module is connected to the serial port of the control unit via RX and TX pins as shown in Figure 3.2. The baud rate of serial ports is 115200 bit/s. The reset pin (RST) of the GSM module is connected to the digital output of the control unit. Pins RX and RST must be connected to the GSM module via a voltage divider because the operating voltage of the GSM module is lower than the control unit's.

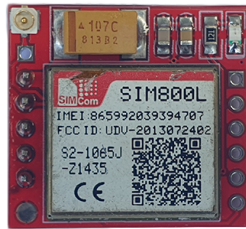

Figure 3.4: GSM module with SIM800L

■ SRR receiver

The device is equipped with an SRR receiver which allows it to receive punch records. The SRR receiver used in the device is part of the SPORTident SRR dongle (Figure 2.5). The inside of the SPORTident SRR dongle and the part of the SRR receiver used in the device are shown in Figure 3.5. The SRR receiver consists of a low power radio frequency transceiver CC2500 and a mixed signal MCU M430F2370 from Texas Instruments. The operating voltage of the SRR receiver is 3.3V with a current supply of at least 30 mA. The SRR receiver has 8 pins through which it can be powered and connected to other devices. The device schematics in Figure 3.2 shows that the SRR receiver is connected to the serial port of the control unit via the RX and TX pin and to a separate power supply via the VCC pin. The baud rate of the serial port is 38400 bit/s. The RX pin of the SRR receiver is connected to the control unit via a voltage divider due to the difference between the operating voltages of the control unit and the SRR receiver. The SRR receiver is configured to receive punches only on the BLUE or RED channel, as described in Section 2.3. The device is equipped with one single receiver for economic reasons. However, practical use of the receiver has shown that using only one receiver on any channel is sufficient to receive punch records with a minimal number of losses.



Figure 3.5: The inner piece of SPORTident SRR dongle

■ Power supply management

The device is powered by lithium-ion (hereafter Li-Ion) battery type 18650. The battery is connected to a micro USB charger module equipped with a constant-current/constant-voltage linear charger TP4056 [Cor22]. The micro-USB charging module is shown in Figure 3.6. The charger module charges the battery and protects the battery from under- and over-charging, which could cause irreversible damage. The battery used in the built devices is GeB 18650-3000 [GeB18]. The capacity of the battery is 3000 mAh with a nominal voltage of 3.7 V. The maximum discharge current is 1500 mAh and the peak discharge current is 9000 mAh, so it works as a sufficient power source for all parts of the device. Two step-up modules equipped with a step-up converter SX1308 [SX10] are used to increase the battery voltage to the required values. The SX1308 is a high-efficiency step-up converter with a fixed switching frequency of 1.2 MHz and a maximum output current of 2 A. The output voltage of the step-up modules can be set with a built-in trimmer. The schematics in Figure 3.2 show that the first step-up module is set to an output voltage of 4 V, which supplies the GSM module, and the second step-up module is set to an output voltage of 5 V and supplies the control unit. The second step-up module also supplies the SRR receiver with a low-dropout regulator (hereinafter LDO), which regulates 5 V to 3.3 V. The schematics also show that the control unit is connected to the positive output and input pins of the charger module, so it can measure the battery

voltage and indicate whether the device is charging or not.

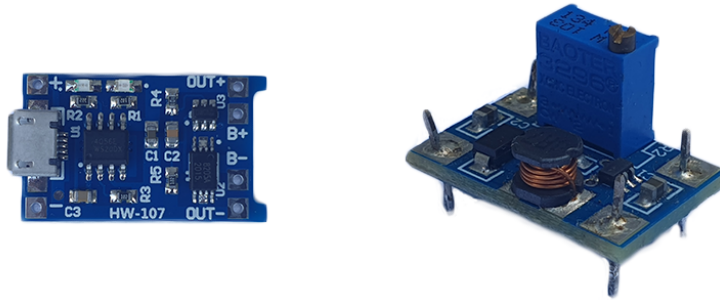

Figure 3.6: The charger module with TP4056 (left) and the step-up module with SX1308 and trimmer (right)

■ PCB and box design

The schematics in Figure 3.2 were converted to a two-layer PCB design in Figure 3.7. A ground plane was placed on the bottom side of the PCB to reduce any interference and electrical noise. The PCB board was made with a photolithographic etching method [Há22]. All components were soldered to the PCB by hand. Figure 3.8 shows the top side of the finished PCB with components.

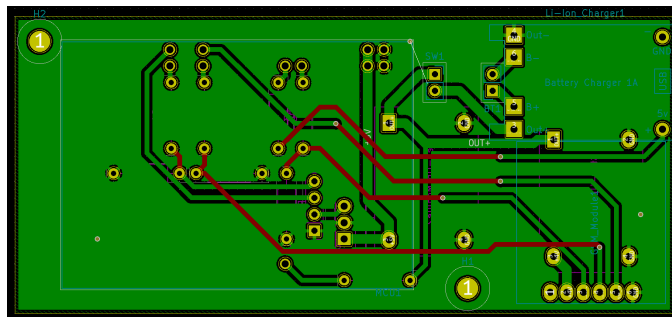

Figure 3.7: PCB design

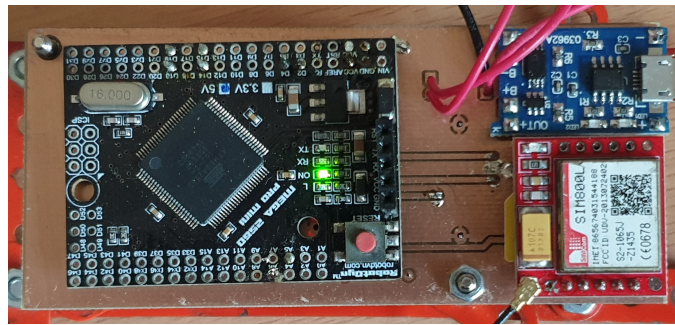

Figure 3.8: Top side of the finished PCB

The 3D model of the device in Figure 3.9 was designed in Fusion 360. The 3D model consists of a box, the PCB, a battery holder, a switch and a GSM antenna as shown in Figure 3.10. The box itself is divided into three parts - box, lid and USB cover piece. All parts of the box, including the PCB and battery holder, are attached to each other with M3 screws. The dimensions of the box are 110 x 50 x 60 mm. The USB cover piece covers a hole for the micro USB connector for charging the device. The specific shape of the device box was chosen so that it could be easily attached to standardised holders, which are used to secure stations at control points. Figure 3.11 shows the device attached to a holder at a control point stand. The box was printed from PLA material on a 3D printer. The box is sealed with a rubber seal to increase the moisture resistance of the device. The rubber seal is placed in the groove on the lid and on the inner side of the USB cover.

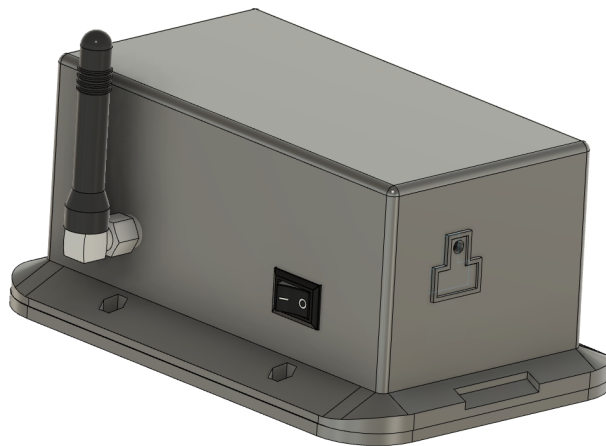

Figure 3.9: The 3D model of the device

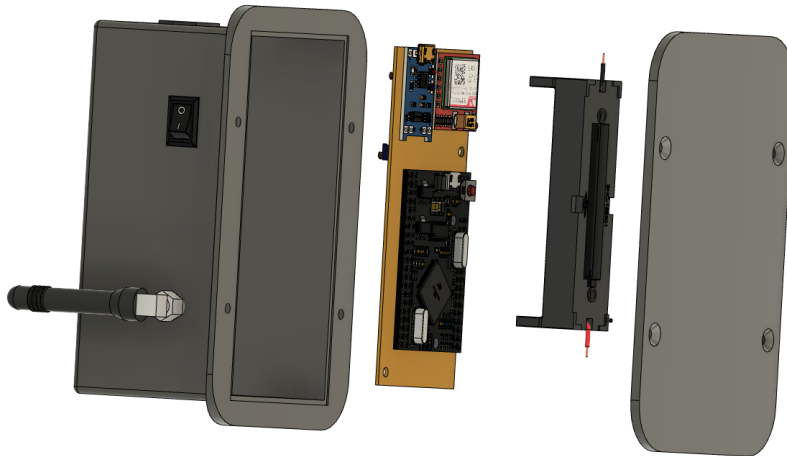

Figure 3.10: Unwrapped 3D model of the device



Figure 3.11: The device attached in the holder at a control point

■ Firmware

The device firmware is written in the C programming language using the Arduino IDE [Ard20]. The main routine of the code is continuously checking the serial buffer of the SRR receiver for new punch records. The received punch records are sent to the server via the mobile network using the Hypertext Transfer Protocol (hereafter HTTP) post requests. Communication of the control unit with the GSM module is made by standardised AT commands via the serial port. The serial buffer size of the ATmega2560 is 64 bytes by

3.1.2 Device based on the RP2040 MCU

Figure 3.12 shows the schematics of the device based on the Raspberry Pi Pico board with the RP2040 MCU. The design of this device is largely based on the device design described in Section 3.1.1. The goal of developing the second device was to reduce its size and use a newer and cheaper MCU. A different approach was also chosen for the development of firmware, which was written in the MicroPython programming language. The firmware is described in more detail in Section 3.1.2.

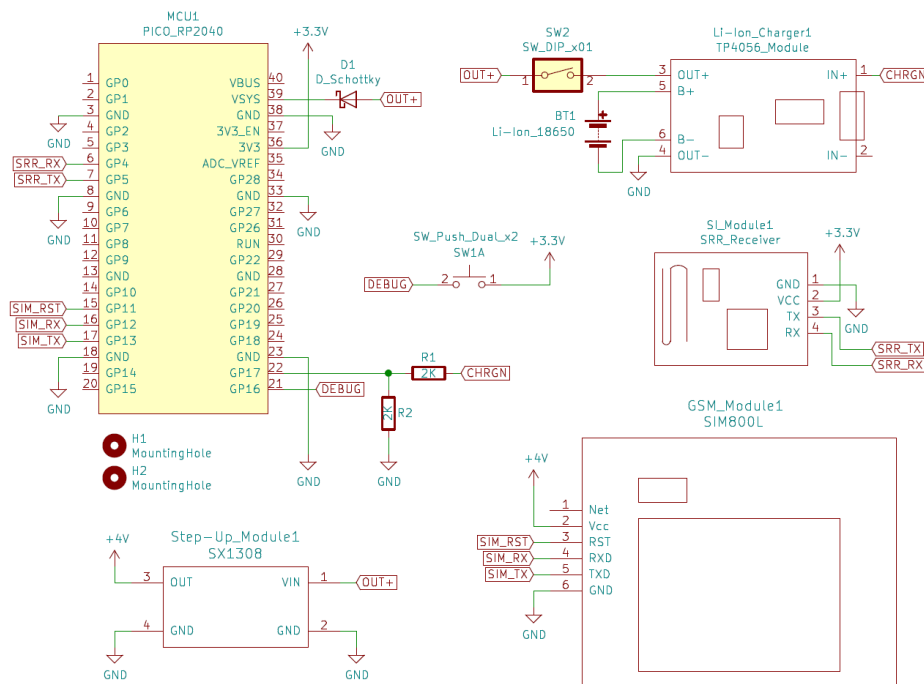

Figure 3.12: Raspberry Pi Pico based device schematics

Control unit

The control unit of the device is the Raspberry Pi Pico board (hereafter Pico). The board is shown in Figure 3.13. Pico [Fou20] is a small and versatile board built on an RP2040 MCU. The RP2040 is a brand new MCU chip developed by Raspberry Pi Foundation in 2020. The RP2040 is a dual-core processor with 16MB of off-chip Flash memory, 264kB on-chip SRAM and two UARTs. The operating voltage of the board is 3.3V. The size of the Flash memory allows its utilization for backup received punch records so they are not lost in case of device reset. Punch records stored on the device can also be used for further analysis of the performance and reliability of the device. The RP2040

supports programming in C/C++ and MicroPython. Another advantage of using the Pico is its even smaller dimensions and cheaper price than the Mega 2560 Pro board.



Figure 3.13: Raspberry Pi Pico board

■ GSM module and SRR receiver

The GSM module and the SRR receiver used on the device are the same as described in Section 3.1.1. The GSM module is connected to UART 0 and the SRR receiver is connected to UART 1 of the control unit. UART 0 of the control unit is also used to connect to a computer to upload new firmware and debugging. Therefore, the GSM module must be disconnected from the power supply when the control unit is connected to a computer to avoid overlapping the data flow. The SRR receiver is powered by the 3V3 output pin of the control unit. As can be seen in the schematic in Figure 3.12, there is no need for voltage dividers at the connections of the GSM module and the SRR receiver to the control unit. The control unit and the SRR receiver operate at the same 3.3V voltage level, as do the data pins of the GSM module.

■ Power supply management

The power to the device is supplied with a Li-Ion battery connected via the charger module (Figure 3.6) as described in Section 3.1.1. The GSM module is also powered via the step-up module (Figure 3.6) in the same way as the device in Section 3.1.1. The main difference is that the control unit can be powered directly from the output of the charger module. The Pico board is equipped with an onboard switched-mode power supply (SMPS), which can

generate 3.3 V from an input voltage in the allowed range of 1.8 V to 5.5 V. A Schottky diode is added to the board's power input so that when the board is powered from the computer, no voltage passes to the rest of the device disconnected from the power supply. The battery voltage is measured directly on the board from the input voltage, so there is no need for an additional connection to the battery. The control unit is connected to the positive input pin of the charger module via a voltage divider so that it can safely measure whether the device is charging or not.

■ PCB and box design

The PCB and the box were designed and built using the same methods and materials as described in Section 3.1.1. Figure 3.14 shows the two-layer PCB design with a ground plane placed in the bottom layer and Figure 3.15 shows the top side of the finished PCB with components.

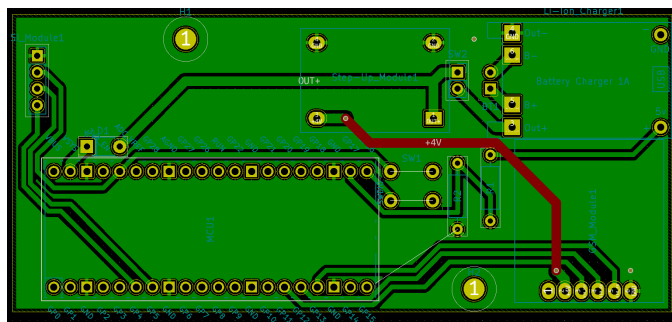

Figure 3.14: PCB design



Figure 3.15: Top side of the finished PCB

The 3D model of the device in Figure 3.16 is smaller than the device in Section 3.1.1. The dimensions of the device are 110 x 40 x 60 mm. Figure 3.17 shows all modelled parts of the device 3D model. The shape of the box again allows for easy attachment of the device to standard holders at control points.

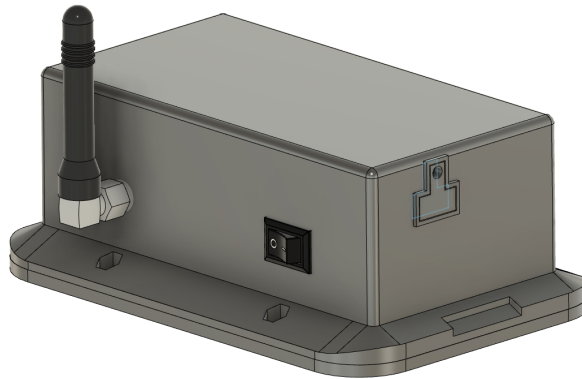

Figure 3.16: The 3D model of the device

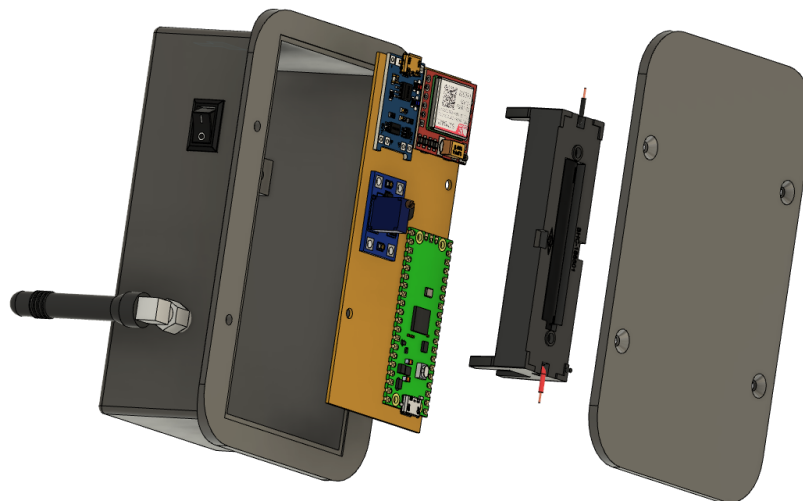

Figure 3.17: Unwrapped 3D model of the device

■ Firmware

The device firmware was written in the MicroPython programming language [Geo14]. MicroPython is an implementation of the Python 3 programming language that is optimised to run on microcontrollers and includes a subset of the Python standard library. MicroPython aims to allow users to easily transfer code from desktops to microcontrollers or embedded systems. The goal of

writing the firmware of the device in MicroPython was to try a new modern method of writing the firmware and to explore the advantages and disadvantages of MicroPython. The device works in two modes, the main routine mode and the debug mode. The debug mode is entered by pressing the external button while connecting a micro-USB cable to the Pico board. The button is shown in the schematics in Figure 3.12. The debug mode allows a user to enter the board's terminal and upload new firmware. The main routine works in a similar way as described in Section 3.1.1. The main difference is that the firmware now uses the flash memory of the board. The main routine is divided into two parts. The first part is continuously checking the serial buffer of the SRR receiver for new punch records. The serial buffer size of the RP2040 is 256 bytes by default, so it can store up to 12 punch records. All received punch records are saved in a temporary file in Flash memory. The second part of the main routine is to check the temporary file for new punch records, and whenever the temporary file is not empty, it sends the punch records to the server. The unsent records will remain in the temporary file and will not be lost if the device restarts unexpectedly. The temporary file is cleared after a positive response from the server and sent punch records are saved in the log file. The data from the log file can then be used for further analysis. The device also sends its status to the server.

■ 3.2 Software

The software application running on the server consists of a database (Section 3.2.1), backend (Section 3.2.2) and frontend (Section 3.2.3). The main purpose of the application is to sort and store all incoming punch records so they can be present during competitions. The user can also monitor the incoming traffic and status records of all devices deployed during the competition.

■ 3.2.1 Database

The system uses a MySQL database. The structure of the database is shown in Figure 3.18. The database consists of four tables - punches, devices, statuses and competitions. Each table stores the data of the corresponding object with the same name - punch, device, status, and competition.

The punch is an object of a punch record. Each punch has a competition ID (`comp_id`) and a punch ID (`punch_id`). The competition ID is a foreign

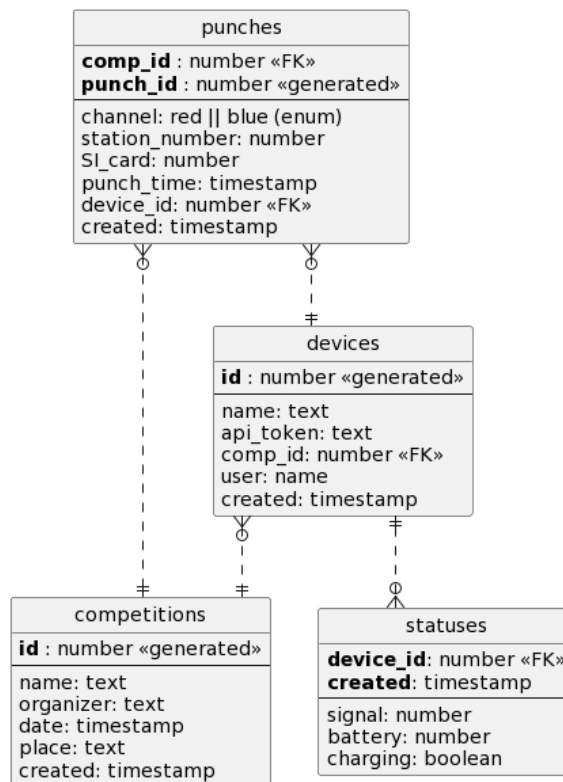

Figure 3.18: Database structure

key from the competition table, and it is a unique number of the competition to which the punch belongs. The punch ID is an incremented integer from one, so it defines the order of the received punches of the competition. The combination of the competition ID and the punch ID is unique for each punch. The device ID (`device_id`) is a foreign key in the device table and serves as a unique identifier for the device that sent the punch record. The channel, station number, SI-Card and punching time are information about the punch record from the SRR receiver. The attribute called `created` is the timestamp when the punch was created on the server.

The device object has its unique ID as an integer. The competition ID (`comp_id`) is a foreign key from the competitions table and defines to which competition the punch records sent by the device belong. The `api_token` is a 31-character long string generated with the message digest algorithm (MD5). The API token is unique for each device and serves as a protection element for uploading data from the device to the server. The use of API tokens is described in more detail in Section 3.2.2. The remaining attributes of the device object are a name, a user (who uses the device), and created (device creation timestamp).

Statuses are uniquely identified with a combination of their device ID (a foreign key from the device table) and status creation timestamp. Each status stores the signal strength value, battery percentage, and whether the device is currently charging or not. The last table contains information about competitions registered in the system which are uniquely identified with competition ID. The competition object bears its name, organiser, date and place of the competition.

3.2.2 Backend

The backend part of the application defines the API of the system. The API is written in the PHP programming language. The API defines CRUD methods for all objects of the system defined in Section 3.2.1. CRUD methods are create, read, update, and delete which are basic operations of persistent data storage. The path to each method of the specific object is defined as `/api/{object}/{method}.php`. Input and output data of each CRUD method are in JSON format. The input JSON is specific to each method. For example, if a user wants to create a new device the path to the method is `/api/device/create.php` with the input JSON shown in Listing 3.1.

Listing 3.1: An example of the input JSON of `device/create.php` method

```
{
  "name" : "R2-D2",
  "user" : "luke",
  "comp_id" : 1,
  "api_token": "API_TOKEN101"
}
```

Listing 3.1 shows that to create a new device an API token is needed. The API token is a security key without which it is not possible to create, update or delete any objects in the system. This is a simple security solution so that no unwanted person can interfere with the system database. However, all read methods can be called without the API token because they do not change any data in the database. The specific forms of input and output JSON of all methods are described in the code in Appendix B.

■ Orienteering software integration

In addition to the CRUD methods, three methods have been added to the punch object. The methods are called `rawsplits`, `roc`, and `meos`. These methods allow the system to be integrated into orienteering software. The `meos` was defined on the basis of the Meos input protocol [HB22] and can be used in the Meos software. The `roc` method was defined based on the Radio Online Control system [BB20] and can be used in the Meos and OE2015 software. The `rawsplits` method returns a text file with punch records data which is used in the OB2000 and QuickEvent software and the Liveresultat Client application [Lof22]. The input and output formats of all described methods can be explored in the code in the Appendix B.

■ 3.2.3 Frontend

The frontend part of the application was also written in PHP programming language using an open-source frontend framework Material Dashboard Lite [IT19] by Creative IT. The frontend design is responsive, so it can also be easily used via mobile devices. The frontend application consists of five pages. The first page serves as a presentation and contains a brief description of the entire system. The second page serves as the device status monitor shown in Figure 3.19. The device status monitor shows a table of all public devices registered in the system. The device information displayed in the table is the device name, the competition ID to which the device belongs, whether the device is online and what is the current signal strength and battery percentage of the device.

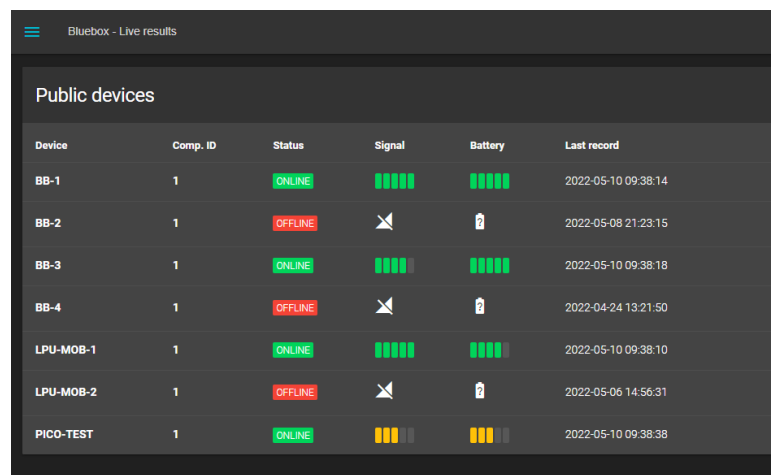

Device	Comp. ID	Status	Signal	Battery	Last record
BB-1	1	ONLINE	██████	██████	2022-05-10 09:38:14
BB-2	1	OFFLINE	✕	🔋	2022-05-08 21:23:15
BB-3	1	ONLINE	██████	██████	2022-05-10 09:38:18
BB-4	1	OFFLINE	✕	🔋	2022-04-24 13:21:50
LPU-MOB-1	1	ONLINE	██████	██████	2022-05-10 09:38:10
LPU-MOB-2	1	OFFLINE	✕	🔋	2022-05-06 14:56:31
PICO-TEST	1	ONLINE	██████	██████	2022-05-10 09:38:38

Figure 3.19: Device status monitor

The third page is the punch record traffic monitor, which is shown in Figure 3.20. The punch record monitor displays a table of the last ten received punch records in the database. The table shows the punch ID, the competition ID to which the punch record belongs, the ID of the device that sent the punch record, the channel on which the punch record was received, and the punch record information itself (station number, SI-card number and time). The main purpose of the traffic monitor is to enable the user to test that the deployed device is capable of transmitting punch records and that these punch records are assigned to the right competition.

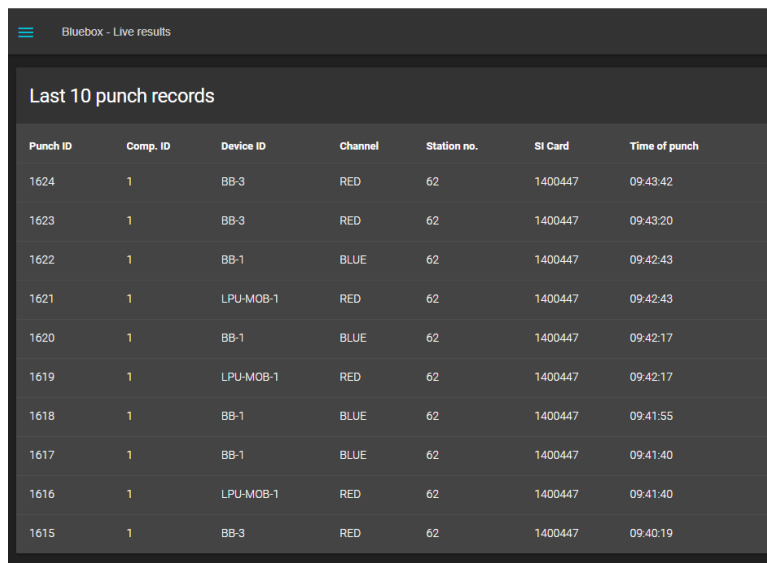

The screenshot shows a web interface titled "Bluebox - Live results". Below the title is a section labeled "Last 10 punch records" containing a table with the following data:

Punch ID	Comp. ID	Device ID	Channel	Station no.	SI Card	Time of punch
1624	1	BB-3	RED	62	1400447	09:43:42
1623	1	BB-3	RED	62	1400447	09:43:20
1622	1	BB-1	BLUE	62	1400447	09:42:43
1621	1	LPU-MOB-1	RED	62	1400447	09:42:43
1620	1	BB-1	BLUE	62	1400447	09:42:17
1619	1	LPU-MOB-1	RED	62	1400447	09:42:17
1618	1	BB-1	BLUE	62	1400447	09:41:55
1617	1	BB-1	BLUE	62	1400447	09:41:40
1616	1	LPU-MOB-1	RED	62	1400447	09:41:40
1615	1	BB-3	RED	62	1400447	09:40:19

Figure 3.20: Punch record traffic monitor

The fourth page, shown in Figure 3.21, displays a table of all competitions registered in the system. The table shows the competition name, ID, who is the organizer of the competition, the place of the competition and the date when it is organized. The fifth page contains some other documents that the user can download, such as manuals on how to use the devices or how to set up any orientation software.

ID	Name	Organizer	Date	Place
26	Test na sprintové štafety	Admin	2022-05-06	Test
25	Český pohár štafet	LPU	2022-04-24	Nové Město na Moravě
24	Český pohár štafet, Mistrovství oblasti	LPU	2022-04-23	Nové Město na Moravě
23	Konický kotár 2022	KON	2022-04-23	Valchov u Boskovic
22	Velikonoce ve skalách - E1	DKP	2022-04-15	Jestřebí
21	Východočeský pohár	LPU	2022-03-26	Semín
20	Předjarní kotár	KON	2022-03-12	Ošikov
19	Ptenské podzámčí	PTE	2022-02-20	Ptení
18	Krátký den	ZBM	2022-01-22	Dubříany

Figure 3.21: Page with competitions registered in the system

Chapter 4

System deployment and measurements

The developed system has been used in real competitions since autumn 2020. This chapter describes the equipment that was used in each competition, the list of competitions in which the system was used, the reliability of the system and other measurements.

4.1 Devices used in the competitions

Six devices were built and used in competitions. The devices are labelled BB-1 to BB-6 to distinguish them. The devices are shown in Figure 4.1. All devices were equipped with a SIM card of the mobile network provider T-Mobile in all competitions. BB-1 to BB-6 are devices based on the ATmega2560 MCU described in Section 3.1.1. Unfortunately, no device based on the RP2040 MCU described in the Section 3.1.2 was tested in any competition at the time of the thesis writing. The devices were always placed at a maximum distance of one meter and a half meter from the control stations at a similar height level. The devices were either mounted on a separate control point stand, which is shown in Figure 4.2, or on the same stand as a control station, which is shown in Figure 4.3. In addition to the received records, each device sends its status every 30 seconds, consisting of the battery voltage and the signal strength of the mobile network.

4. System deployment and measurements



Figure 4.1: Built devices that were used in competitions.



Figure 4.2: BB-1 device mounted on a separate stand during the Prague Easter competition. Photo by V. Illner [1122]



Figure 4.3: BB-2 device mounted on the same stand with the control station during the Czech Championship in Sprint Relay 2022. Photo by A. Švarc [Šv22]

4.2 Competitions where the system was used

The system was used in a total of 18 different competitions, including 3 national championships. Table 4.1 shows a list of all competitions in which the system was used. The table contains the name of each competition, the place and the date of its holding. Each competition was assigned a number in the order column, which refers to the individual competitions in the following sections. The use of individual devices in competitions was given by the organisers requirements. Therefore, not all devices were used in all competitions. The system has been used in all types of orienteering competitions (sprint, middle-distance, long-distance and relays) in forest and urban areas. The individual competitions vary in difficulty from the system's point of view. The middle and long distance competitions (numbers 2 to 16) were organised in large forest areas with weak mobile signals. The competitions number 1, 11, 12, 15, 16 and 18 were relays which challenged the system with a large number of competitors passing a control point at the same time. The most demanding competition was the Czech Championship in Sprint Relay 2022 (number 18), because it was also broadcast live on the Czech Television channel ČT Sport and the split times provided by the system were displayed in the television graphics. A screenshot of the live broadcast on ČT Sport is shown in Figure 4.4.

Order	Competition	Place	Date
1	Czech Champ. in Sprint Relay	Pardubice	06-09-2020
2	Ranking B-Bohemia East	Vysoká u Holic	29-05-2021
3	Ranking B-Bohemia East	Vysoká u Holic	30-05-2021
4	Czech Master Champ.	Žďárský Potok	26-06-2021
5	East Bohemia Price - stage 1	Pustá Rybná	27-08-2021
6	East Bohemia Price - stage 3	Pustá Rybná	29-08-2021
7	Manufaktura Czech Cup - ranking A	Kladky	04-09-2021
8	Manufaktura Czech Cup - ranking A	Valchov	05-09-2021
9	Czech Long Distance Champ. (qual.)	Pohoří	18-09-2021
10	Czech Long Distance Champ. (finale)	Pohoří	19-09-2021
11	Czech Relay Cup	Dolní Olešnice	25-09-2021
12	Czech Relay Cup	Dolní Olešnice	26-09-2021
13	East Bohemia Cup	Semín	26-03-2022
14	Prague Easter	Jestřebí	15-04-2022
15	Czech Relay Cup	Nové Město na M.	23-04-2022
16	Czech Relay Cup	Nové Město na M.	24-04-2022
17	Czech Champ. in Sprint	Praha	14-05-2022
18	Czech Champ. in Sprint Relay	Praha	15-05-2022

Table 4.1: List of competitions where the system was used



Figure 4.4: The system was used in the ČT Sport live broadcast of the Czech Championship in Sprint Relay.

4.3 System reliability

The most important metric for the system is its ability to transfer as many punch records as possible, and thus its punch record transmission reliability. Tables 4.2 and 4.3 show the results of the competitions for each device.

The first columns of the tables are numbers corresponding to the competitions listed in Table 4.1. There are three columns for each device. The TR column contains a number of punch records that were transmitted by the device. The AR column contains the actual punch records that were made by competitors at the radio control point where the device was placed. The number of actual punch records was obtained by checking the competition results and split times from the ORIS application. The DR column is a computed ratio between transmitted and actual punch records and represents the device's transmission reliability in percentage. The last row of Tables 4.2 and 4.3 shows the sums of transmitted and actual punch records of each device in all competitions and the overall device transmission reliability in percentage. It can be seen that the transmission reliability of a device can be up to 100%. The device transmission reliability results vary from competition to competition and it is influenced by multiple factors such as signal strength, device position to the control station or speed of passing competitors with SIACs. For example, Table 4.2 shows that the reliability of the transmission of the BB-3 device was 100% transmitted punch records during competitions 7 and 8, but was also only 39.9% during competitions 9 or 71% during competition 16. The reason for these differences is described more closely in punch records traffic analysis in Section 4.4.

Comp.	BB-1			BB-2			BB-3		
	TR	AR	DR	TR	AR	DR	TR	AR	DR
1	318	323	98.5	269	326	82.5	215	328	65.5
2							487	668	72.9
3	630	630	100.0						
4									
5									
6	563	691	81.5						
7	91	94	96.8	145	179	81.0	357	357	100.0
8	171	349	49.0	308	399	77.2	399	399	100.0
9	176	181	97.2	64	148	43.2	101	253	39.9
10	190	190	100.0	142	188	75.5	179	198	90.4
11	878	1103	79.6				883	1149	76.8
12	932	1073	86.9				810	903	89.7
13	775	932	83.2						
14	649	702	92.5				692	702	98.6
15	480	493	97.4				794	850	93.4
16	829	870	95.3				490	689	71.1
17	436	439	99.3	436	439	99.3			
18				355	356	99.7	187	190	98.4
Sums	7118	8070	88.2	1719	2035	84.5	5594	6686	83.7

Table 4.2: The number of transmitted punch records (TR), actual punch records (AR) and computed device reliability (DR) in percentage of BB-1, BB-2 and BB-3 devices.

4. System deployment and measurements

Comp.	BB-4			BB-5			BB-6		
	TR	AR	DR	TR	AR	DR	TR	AR	DR
1	307	323	95.0						
2									
3									
4	201	218	92.2						
5	536	700	76.6						
6									
7	112	146	76.7						
8	399	399	100.0						
9	157	183	85.8						
10	232	233	99.6						
11	734	1149	63.9						
12	599	665	90.1						
13	750	932	80.5						
14									
15									
16	671	870	77.1						
17				420	439	95.7	424	439	96.6
18	166	166	100.0	356	356	100.0	340	340	100.0
Sums	4864	5984	81.3	776	795	97.6	764	779	98.1

Table 4.3: The number of transmitted punch records (TR), actual punch records (AR) and computed device reliability (DR) in the percentage of BB-4, BB-5 and BB-6 devices.

Table 4.4 sums of all transmitted (TR) and actual (AR) punch records of each competition. The SR column is the system reliability at each competition calculated as the ratio between transmitted and actual punch records. The last row consists of the total sums of TR and AR columns and the average value of SR. It can be seen that the system was able to transfer 20833 punch records and the average system reliability reached 85.6%.

Comp.	Comp. summary		
	TR	AR	SR
1	1109	1300	85.3
2	487	668	72.9
3	630	630	100.0
4	201	218	92.2
5	536	700	76.6
6	563	691	81.5
7	705	776	90.9
8	1277	1546	82.6
9	498	765	65.1
10	743	809	91.8
11	2495	3401	73.4
12	2341	2641	88.6
13	1525	1864	81.8
14	1341	1404	95.5
15	1274	1343	94.9
16	1990	2429	81.9
17	1716	1756	97.7
18	1402	1408	99.6
Sums	20833	24349	85.6

Table 4.4: The number of transmitted punch records (TR), actual punch records (AR) and computed system reliability (SR) in percentage at each competition.

4.4 Punch record traffic analysis

This section focuses on analysing punch record traffic to identify punch record losses during competitions. Punch record traffic was analysed as sums of transmitted and actual punch records in five-minute time frames. Figure 4.5a shows a plot of the BB-3 device punch records traffic during competition number 2. The Y-axis shows the number of punch records and the X-axis shows the race time in seconds. The race time is zero at the start of the first competitor. The blue columns represent the punch records transmitted by the device and the orange columns represent the actual punch records created by passing competitors at each five-minute time frame. The punch record traffic in Figure 4.5a shows that there is a large gap when the BB-3 device did not transmit any punch records during the competition number 2. The gap corresponds to the same gap in the graph of the signal strength of the device shown in Figure 4.5b. This problem was caused by a passing competitor who stepped off the stand with the device, which was thus unable to connect to the local mobile network. The device reconnected after an organiser came to fix the stand and restarted the device. This led to the fact that the device punch transfer reliability was only 65.5% during competition number 2.

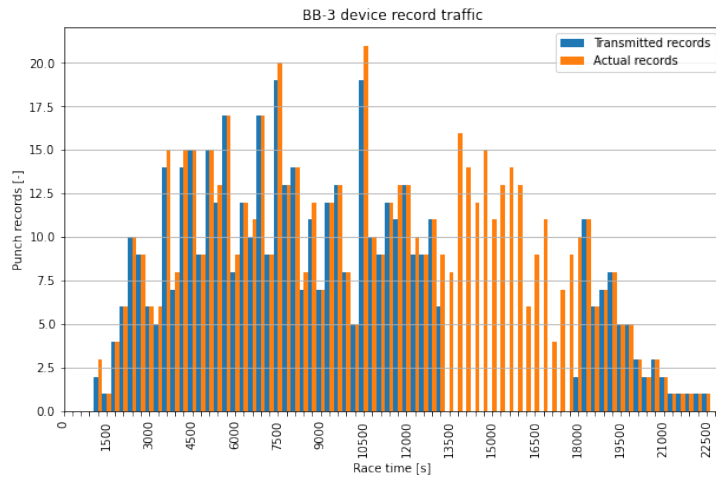

(a) : Punch record traffic

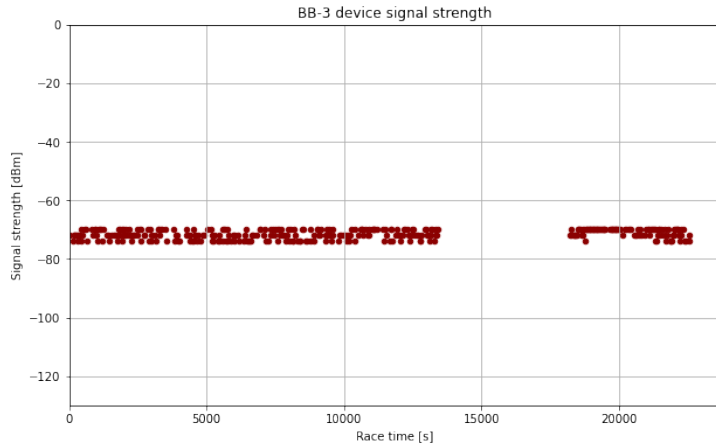

(b) : Signal strength

Figure 4.5: BB-3 device punch records traffic and signal strength during competition number 2.

Figure 4.6 shows that a similar situation also happened during competition number 16. The BB-3 device stopped transmitting any punch records minutes after the start of the competition. The antenna was to blame in this case. After its replacement, the device functioned without complications for the rest of the competition. This problem caused the device reliability of the punch records transmission to drop to only 71.1% during competition number 16.

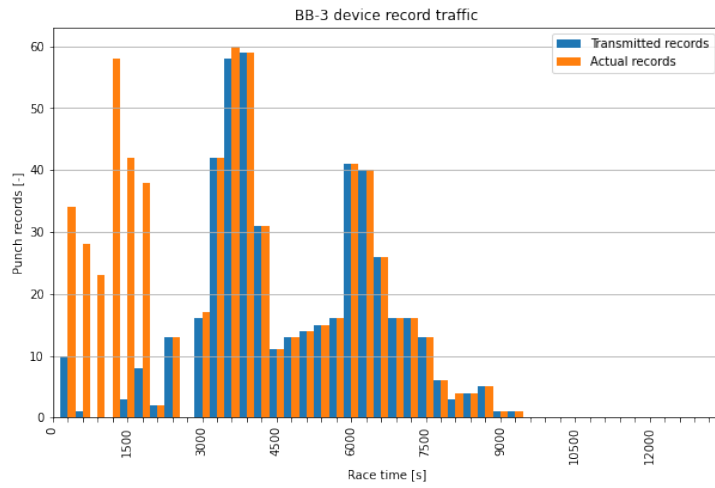

(a) : Punch record traffic

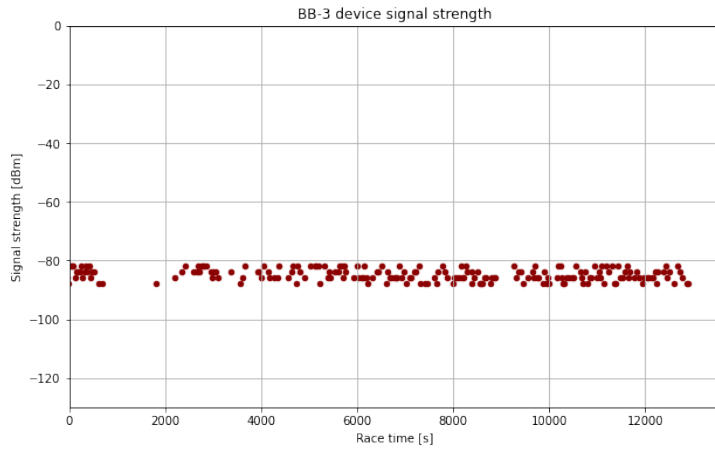

(b) : Signal strength

Figure 4.6: BB-3 device punch records traffic and signal strength during competition number 16.

Figure 4.7 shows punch records traffic and signal strength of the BB-3 device during competition number 8. It is possible to observe that there was no loss of connection during the race. Figure 4.7a also shows that no punch records were lost and that the punch record transmission reliability of the device during competition number 8 was 100%.

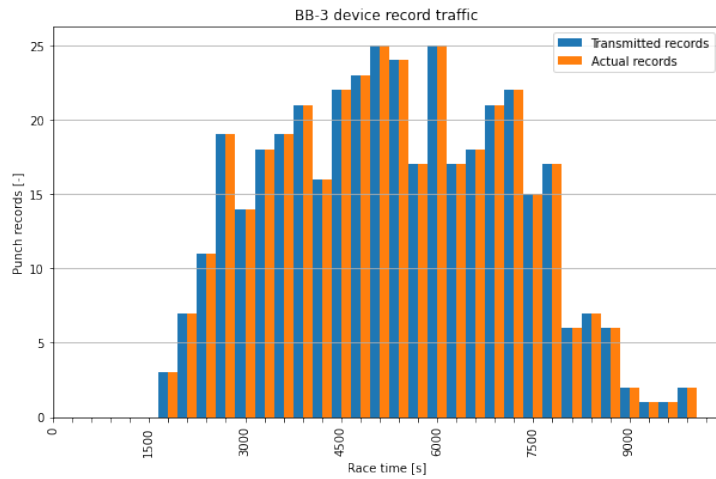

(a) : Punch record traffic

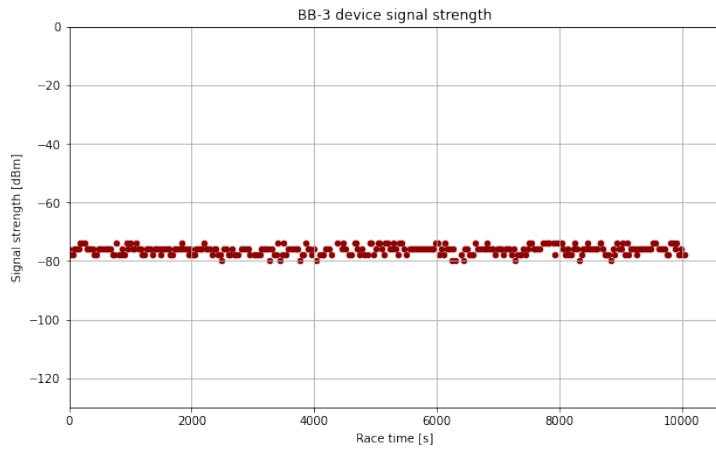

(b) : Signal strength

Figure 4.7: BB-3 device punch record traffic and signal strength during competition number 8.

The same analysis has been done for all devices in each observed competition with a similar observation. Figure 4.8 shows the traffic of the punch records on all devices used during competition 17. It can be seen that the signal strength of all devices was constant during the whole competition and the devices did not experience any loss of connection. This meant that the transmission reliability of all devices was 95% and higher, as shown in the plots in Figure 4.8 and Tables 4.2 and 4.3.

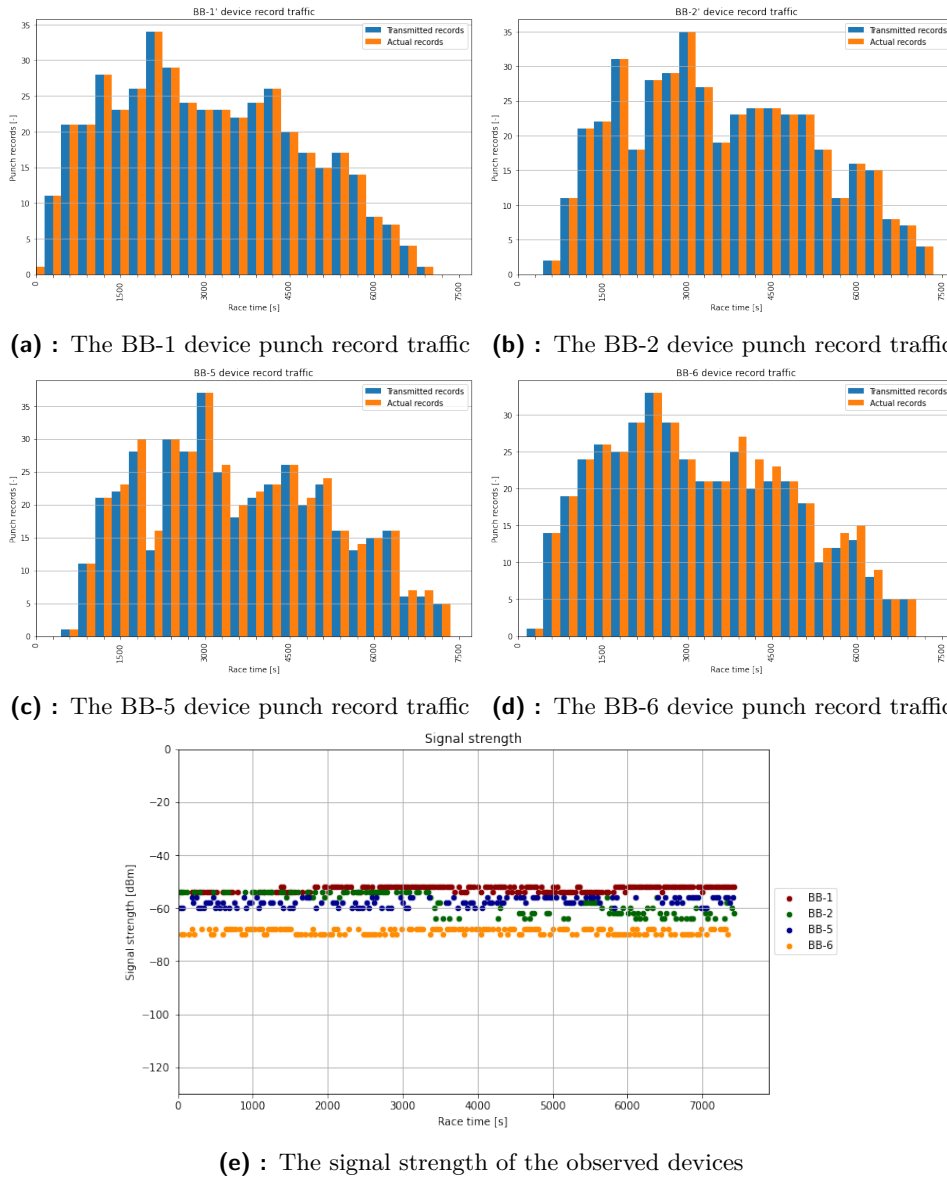

Figure 4.8: Punch record traffic of all devices used in competition number 17.

4.5 Battery voltage and run time

Figure 4.9 shows a graph of the battery discharge process of all devices used during competition number 7. It can be seen that the battery discharge follows linear time dependence. The X-axis of the plot represents the race which is zero at the start of the first competitor. The devices were switched on before the start of the first competitor, which is the reason for the negative time values in the plot. The same linear battery discharge process was observed in all competitions.

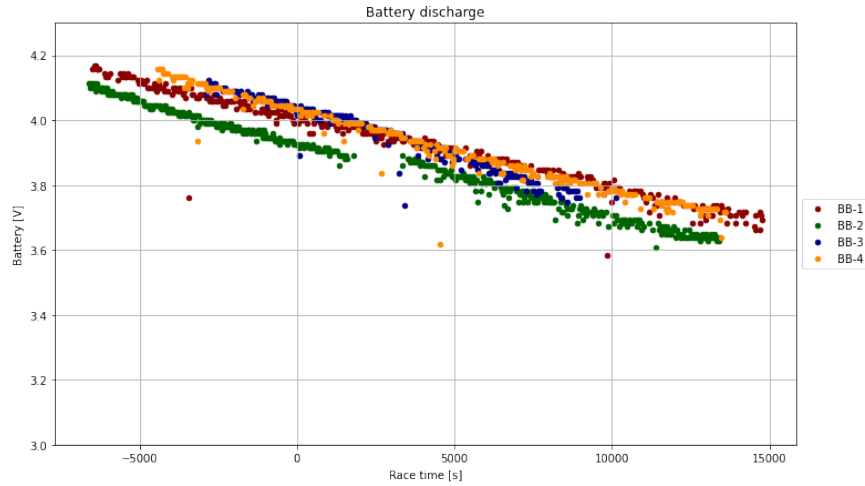

Figure 4.9: The battery voltage of all devices used during competition number 7.

Tables 4.6 to 4.11 shows the battery discharge, run time and average signal strength of each device during the competitions. The SB column consists of the battery voltage values of the device when it was turned on and deployed at the control point. The EB column consists of the battery voltage values at the end of the competition before the device was switched off. As can be seen from the signal strength graphs in Section 4.4, the signal strength of each device was almost constant because the device was always located in one place and did not move throughout the competition. The AS column is the average signal strength value of the device in dBm. The RT column consists run time of the device in minutes. Tables 4.6, 4.9 and 4.7 of the devices that were used during at least ten competitions have an extra column (VD) that consists of values of battery voltage drop per hour computed as

$$VD = \frac{SB - ED}{RT}, \quad (4.1)$$

where SB is the voltage at the start, ED is the voltage at the end and RT is the run time in hours. Experiments during the development of the devices have shown that the charger module is able to charge the batteries up to about 4.15 V when the devices are considered to be fully charged. The lowest possible voltage at which the batteries were able to source the GSM modules with enough current was discovered to be 3.2 V. The device is not able to function properly if the battery voltage is lower than 3.2 V so the device is considered to be fully discharged at this voltage. The results show that the longest run time of 441 minutes has been reached by the BB-4 device with a battery voltage discharge of 0.4 V which was not even close to the full discharge of the device.

The estimated maximum run time (ERT) of a device was computed as

$$\text{ERT} = \frac{\text{FV} - \text{EV}}{\phi\text{VD}}, \quad (4.2)$$

where $\text{FV} = 4.15 \text{ V}$ is the battery voltage at full charge, $\text{EV} = 3.2 \text{ V}$ is the battery voltage at full discharge and ϕVD is an average value of the voltage drop per hour for the device. Table 4.5 shows the estimated maximum run time of the selected devices.

Device	ERT [h]
BB-1	12.3
BB-3	11.6
BB-4	11.6

Table 4.5: Estimated maximum run time of selected devices

Comp.	SB [V]	EB [V]	AS [dBm]	RT [mins]	VD [V/h]
3	4.06	3.65	-52	380	0.065
6	4.10	3.81	-65	260	0.067
7	4.16	3.71	-85	354	0.076
8	3.67	3.55	-75	238	-
9	4.10	3.70	-80	288	0.083
10	4.08	3.66	-74	412	0.061
11	4.13	3.68	-83	372	0.073
12	4.15	3.79	-78	247	0.087
13	4.11	3.85	-70	248	0.063
14	4.13	3.72	-62	321	0.077
15	4.13	3.83	-75	211	0.085
16	4.15	3.71	-80	238	0.111
17	4.15	3.97	-53	140	0.077

Table 4.6: Battery voltage, average signal strength, run time and voltage discharge speed of the BB-1 device

4. System deployment and measurements

Comp.	SB [V]	EB [V]	AS [dBm]	RT [mins]	VD [V/h]
2	4.10	3.61	-72	387	0.076
7	4.10	3.77	-90	217	0.091
8	4.13	3.79	-76	200	0.102
9	4.09	3.72	-93	298	-
10	4.10	3.79	-97	377	0.049
11	4.12	3.66	-73	387	0.071
12	4.10	3.78	-86	213	0.090
14	4.06	3.69	-62	367	0.060
15	4.12	3.73	-67	232	0.101
16	4.10	3.67	-85	231	0.112
18	4.01	3.76	-52	204	0.074

Table 4.7: Battery voltage, average signal strength, run time and voltage discharge speed of the BB-3 device

Comp.	SB [V]	EB [V]	AS [dBm]	RT [mins]	VD [V/h]
4	4.06	3.57	-80	308	0.095
5	4.09	3.77	-74	230	0.083
7	4.15	3.72	-92	300	0.086
8	4.16	3.96	-68	133	0.090
9	4.12	3.71	-86	300	0.082
10	4.06	3.66	-85	441	0.054
11	4.16	3.69	-80	378	0.075
12	4.14	3.73	-75	280	0.088
13	4.12	3.81	-67	209	0.089
16	4.11	3.83	-70	220	0.076
18	4.19	3.86	-56	245	0.081

Table 4.8: Battery voltage, average signal strength, run time and voltage discharge speed of the BB-4 device

Comp.	SB [V]	EB [V]	AS [dBm]	RT [mins]
7	4.11	3.64	-83	334
8	4.10	3.84	-62	202
9	4.13	3.63	-80	341
10	4.13	3.78	-78	212
17	4.14	4.11	-59	224
18	4.16	4.05	-52	243

Table 4.9: Battery voltage, average signal strength and run time of the BB-2 device

Comp.	SB [V]	EB [V]	AS [dBm]	RT [mins]
17	4.12	3.95	-58	223
18	4.11	3.82	-55	243

Table 4.10: Battery voltage, average signal strength and run time of the BB-5 device

Comp.	SB [V]	EB [V]	AS [dBm]	RT [mins]
17	4.07	3.95	-69	182
18	4.08	3.90	-53	242

Table 4.11: Battery voltage, average signal strength and run time of the BB-6 device



Figure 4.10: The BB-5 placed on the stand of the finish control point of the Czech Championship in Sprint 2022. Photo by J. Čech [Če22]



Chapter 5

Discussion

The results of the system deployment in real competitions from Section 4 showed that the system consists of hardware devices and a server application is capable to handle the transmission of punch records at all types of orienteering competitions from long-distance races to relays. Section 4.4 shows that the built devices were able to transmit at least 80% of punch records which would be not enough to satisfy the needs of the competition organisers. However, the punch record traffic analysis from Section 4.4 shows that the punch record losses were mostly caused by the wrong placement of the device near the control point station or by an accidental misplacement of the device by a passing competitor which caused the device to not be able to connect to a local mobile network and transmit punch records. The problem of punch record losses due to lost mobile network connection is fixed by first saving all received punch records in the flash memory of the device, which is introduced in the design of the device based on the RP2040 MCU described in Section 3.13. However, because the system is used to provide the live results during the competition to the audience before the competitors finish the race, the system priority has to be providing the punch records as soon as possible. The experience from competitions with low punch record transmission reliability shows that the placement of the device at the control point station is very important. In order to improve the system reliability, the devices were placed directly on the control point stands during competitions 17 and 18. The placement of the devices is shown in Figures 4.3 and 4.10. As the results in Tables 4.2, 4.3 and 4.4, this led to a significant improvement of the system punch record transmission reliability when each device reached reliability of 96% and more.

The measurements of battery voltage from Section 4.5 shows that the aver-



Chapter 6

Conclusion

The system for transmission, processing and presentation of live results during orienteering competitions has been developed, implemented and tested. The design of the hardware and software parts is described in Chapter 3. Two types of hardware devices were developed within the system. The first device is based on the ATmega2560 MCU and the second is based on the RP2040 MCU. The devices use a local mobile network to connect to the Internet and transmit punch records of passing orienteering competitors. The software part of the developed system consists of a server application that is able to process incoming punch records from hardware devices in the field and pass them to an orienteering software used by the organisers. The system was deployed and used in a total of 18 competitions, including three national championships. The biggest success of the system so far was its deployment at the Czech Championships in Sprint Relay 2022 which was also broadcast live on national television with live results provided by the system developed in this thesis.



Appendix A

Bibliography

- [Ard20] Arduino, *Arduino IDE source code*, <https://www.github.com/arduino/Arduino>, 2020, [Online; accessed May 1, 2022].
- [BB20] O. Berg and E. Berg, *Radio Online Control*, http://olresultat.se/blog/?page_id=148, 2020, [Online; accessed May 1, 2022].
- [Chm18] M. Chmelař, *OB2000*, <http://www.obhana.cz/SW/SW.htm>, 2018, [Online; accessed May 1, 2022].
- [Com22] Freepik Company, *Flaticon Image Bank*, <https://www.flaticon.com/>, 2022, [Online; accessed May 1, 2022].
- [Cor22] NanJing Top Power ASIC Corp., *TP4056 Datasheet*, https://www.laskakit.cz/user/related_files/tp4056.pdf, 2022, [Online; accessed May 1, 2022].
- [Fed20] International Orienteering Federation, *Website homepage*, <https://orienteering.sport/>, 2020, [Online; accessed April 28, 2022].
- [Fou20] Raspberry Pi Foundation, *Raspberry Pi Pico datasheet*, <https://datasheets.raspberrypi.com/pico/pico-datasheet.pdf>, 2020, [Online; accessed May 1, 2022].
- [GeB18] GeB, *Li-ion Cylindrical Battery Specification*, https://www.laskakit.cz/user/related_files/geb_18650_3_7v_3000mah_-_datasheet.pdf, 2018, [Online; accessed May 1, 2022].
- [Geo14] D. George, *MicroPython Website*, <https://micropython.org/>, 2014, [Online; accessed May 1, 2022].

- [Vod22] Vodafone, *NB-IoT - Vodafone.cz*, <https://www.vodafone.cz/podnikatele/internet-veci/nb-iot1/>, 2022, [Online; accessed May 16, 2022].
- [Če20a] Český svaz orientačních sportů, *Informační systém ČSOS*, <https://oris.orientacnisporty.cz/>, 2020, [Online; accessed May 1, 2022].
- [Če20b] ———, *Směrnice - Ověřené systémy označování závodních průkazů*, <http://www.orientacnibeh.cz/upload/dokumenty/sekce-ob/smernice-razeni-19.pdf>, 2020, [Online; accessed April 28, 2022].
- [Če22] J. Čech, *220514 MČR Sprint Stodůlky*, <https://eu.zonerama.com/JCechSJI/Album/8409422>, 2022, [Online; accessed May 16, 2022].
- [Šv22] A. Švarc, *MČR Sprint a Sprintové Štafety*, <https://eu.zonerama.com/TondaSvarc/Album/8407527>, 2022, [Online; accessed May 16, 2022].



Appendix B

Content of enclosed CD

Listing B.1: Content of enclosed CD

```
CD:  
|---juricja1_DP.pdf  
|---arduino  
|---pico  
|---phpweb
```