

**Bachelor Project**



**Czech  
Technical  
University  
in Prague**

**F3**

**Faculty of Electrical Engineering  
Department of Microelectronics**

## **Motherboard design for desalination unit**

**Kryštof Pešek**

**Supervisor: Ing. Vít Záhlava, CSc.  
December 2021**



## Acknowledgements

I would like to thank my whole family for their support in life and my studies. Thanks to them, I was able to continue my hobby in college and in professional life. I want to thank all my friends for sharing the joys and difficulties of college life with me. Special thanks also go to those who named the relays on my board. I am grateful for all the knowledge I have gained from my professors. I also appreciate all the valuable advice I received from my supervisor, Ing. Záhlava.

## Declaration

„Prohlašuji, že jsem předloženou práci vypracoval samostatně a že jsem uvedl veškeré použité informační zdroje v souladu s Metodickým pokynem o dodržování etických principů při přípravě vysokoškolských závěrečných prací.“

V Praze, 1. prosince 2021

## Abstract

This thesis describes the designing and development of a desalination unit motherboard. The board replaces the currently used control unit. Its main goal is to reduce the production cost while adding additional features.

The production process is managed by a microcontroller. It also evaluates the data from sensors. The user interface is provided by an LCD and a rotary encoder. It informs the user about the current production state and shows the temperature and pressure in the system. The serviceman can also use it to change the production settings to fit local conditions.

I was able to create a working prototype of the control board. I successfully uploaded the firmware to the microcontroller and tested all the device features.

**Keywords:** Desalination unit, desalter, reverse osmosis, microcontroller, relay

**Supervisor:** Ing. Vít Záhlava, CSc.  
Department of Microelectronics,  
Technická 1902/2,  
166 27 Praha 6

## Abstrakt

Tato práce popisuje návrh a vývoj základní desky odsolovacího zařízení. Deska nahrazuje aktuálně používanou řídicí jednotku. Hlavním cílem projektu je snížit výrobní náklady a přidat další funkce.

Výrobní proces je řízen mikrokontrolérem. Ten také vyhodnocuje data ze senzorů. Uživatelské rozhraní zajišťuje LCD a rotační enkodér. Informuje uživatele o aktuálním stavu výroby a zobrazuje teplotu a tlak v systému. Servisní technik jej také může použít ke změně nastavení výroby, aby vyhovovala místním podmínkám.

Podářilo vytvořit funkční prototyp řídicí desky. Úspěšně jsem nahrál firmware do mikrokontroléru a otestoval všechny funkce zařízení.

**Klíčová slova:** Odsolovací zařízení, odsolovačka, reverzní osmóza, mikrokontrolér, relé

**Překlad názvu:** Návrh základní desky pro odsolovací zařízení

# Contents

<b>1 Introduction</b>	<b>1</b>
<b>2 Desalination</b>	<b>3</b>
2.1 History . . . . .	3
2.2 Desalination technologies . . . . .	4
2.2.1 Thermal technologies . . . . .	4
2.2.2 Membrane technologies . . . . .	6
2.2.3 Ecology . . . . .	8
<b>3 Implementation</b>	<b>11</b>
3.1 Hardware . . . . .	11
3.1.1 Mechanics . . . . .	11
3.1.2 Parts and components . . . . .	13
3.1.3 Working principles . . . . .	16
3.2 Firmware . . . . .	21
3.2.1 Production process . . . . .	21
3.2.2 User interface . . . . .	22
3.3 Second version . . . . .	22
3.3.1 Hardware . . . . .	22
3.3.2 Software . . . . .	23
<b>4 Conclusion</b>	<b>25</b>
<b>Bibliography</b>	<b>27</b>
<b>A List of Notation</b>	<b>31</b>

## Figures

## Tables

2.1 Freshwater Availability . . . . .	3
2.2 Multi-stage fresh desalination process . . . . .	4
2.3 Multi-effect distillation process . .	5
2.4 Vapor compression distillation process . . . . .	5
2.5 Example of a solar still desalination process . . . . .	5
2.6 Example of an electro dialysis process . . . . .	6
2.7 Basic components of membrane treatment process . . . . .	6
2.8 Range of nominal membrane pore sizes for reverse osmosis, nanofiltration, ultrafiltration, and microfiltration . . . . .	7
2.9 Cutaway view of a spiral reverse osmosis membrane element . . . . .	7
2.10 Cross section of a pressure vessel with three membrane elements . . . .	8
2.11 Most common brine disposal methods in the United States[15] . .	8
2.12 Comparison of Brine Management Methods[15] . . . . .	9
3.1 Layout of the functional blocks of the bottom board. . . . .	12
3.2 Layout the top board. . . . .	12
3.3 Estimated number of switching cycles [17] . . . . .	15
3.4 Optocoupler [19] . . . . .	15
3.5 Power input overvoltage protection schematic . . . . .	16
3.6 Sensor input overvoltage protection schematic . . . . .	17
3.7 Phase sensing circuit schematic .	18
3.8 Collector current vs. collector-emitter voltage[20] . . . . .	18
3.9 Relay switching circuit . . . . .	19
3.10 Alarm output schematic . . . . .	19
3.11 Relay schematic . . . . .	20
3.12 Production diagram . . . . .	21



# Chapter 1

## Introduction

The desalination unit, desalter, is a device used to produce freshwater from regular seawater. I will describe the processes used for water desalination. I will also write about thermal technologies such as multi-stage distillation, multi-effect distillation, vapor compression distillation, and solar distillation. I will discuss membrane technologies such as electrodialysis, electrodialysis reversal, and reverse osmosis. I am also planning to address the ecological risks connected with desalination.

The main focus of my work will be to design a device, which will replace the currently used control unit. The current unit uses discrete timers and relays to control the production process. My goals are to reduce the price and production time while adding additional features. I am planning to create a click-in module, which will easily fit into any usual fuse box. It will simplify the installation process to just connecting the wires to the terminals.

I decided to control the board using a microcontroller. I will design my own firmware to manage the whole production process. It will provide a user interface, evaluate the data of the sensors, and control the desalter using relays. I will also implement input protections, a relay switching circuit, zero sensing, and a phase sensing circuit.

I will design my own PCB for this project. I am also going to pick all the parts and components. In the end, I am planning to manufacture a functional prototype and test all the functions of the board in laboratory conditions.





## Chapter 2

### Desalination

Desalination, also called desalting is a process of removing salts from water. This process uses otherwise unusable sources like seawater, brackish, or highly mineralized waters and converts them to fit for human consumption and industrial applications. The desalination process requires large amounts of energy, usually provided by a power grid. [2] Due to this reason, desalters or desalination plants are used only where sources of freshwater are not available. The picture below shows freshwater availability in the world. Most of the desalination plants are located in the yellow and orange regions.

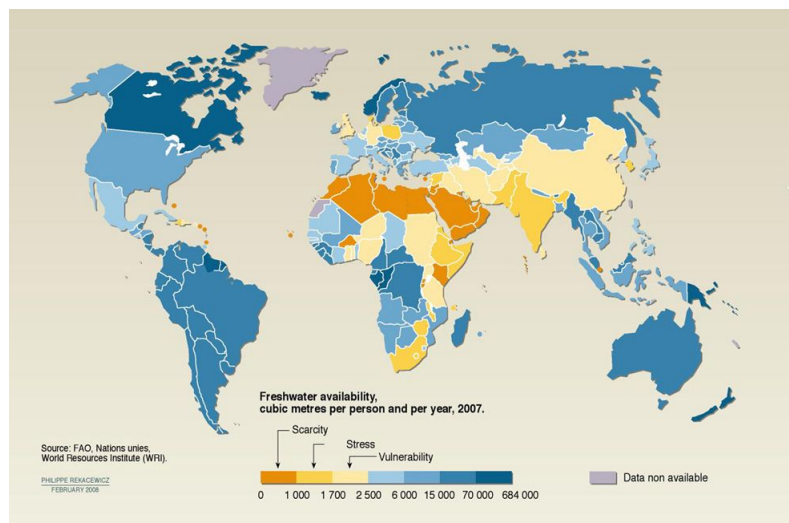

Figure 2.1: Freshwater Availability

### 2.1 History

The desalting of seawater was known already in ancient times. Aristotle described an evaporation method used by Greek sailors of the 4th century BCE. In the 19th century, the first patent for the desalination process was granted in England. That was due to demand for noncorroding water for ship boilers, used to power steam engines. In 1869 the first desalination plant

was built in Aden, to supply ships at the Red Sea port. By 2019, there were about 18000 desalination plants in the world, producing over 95 million cubic meters of freshwater every day [5].

## 2.2 Desalination technologies

The primary technologies used around the world for desalination are thermal desalination and membrane desalination. Thermal desalination is primarily used in the Middle East. Major thermal processes are multistage flash distillation (MSF), multi-effect distillation (MED), and vapor compression distillation (VCD). Another method is solar distillation, used primarily for small production rates [6].

### 2.2.1 Thermal technologies

#### Multi-stage flash distillation

Multi-stage flash distillation uses multiple chambers, in which the water is heated and pressurized. As the water progresses through the chambers, pressure is reduced, causing water to rapidly boil. The vapors contain only fresh water and the salt and other minerals remain solid. The steam is then condensed and collected as a product [6].

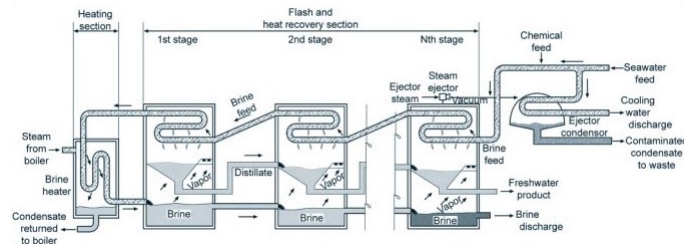

Figure 2.2: Multi-stage flash desalination process

#### Multi-effect distillation

Multi-effect distillation uses similar principles to multi-stage flash distillation. The only difference is that instead of using multiple chambers of a single vessel, MED uses successive vessels. The water vapor that is formed when the water boils is condensed and collected. The multiple vessels make the MED process more efficient [6].

#### Vapor compression distillation

Vapor compression distillation can be used separately or in combination with other thermal desalination processes. The process uses heat from compressed vapors of freshwater to heat the brine. VCD is usually used to produce

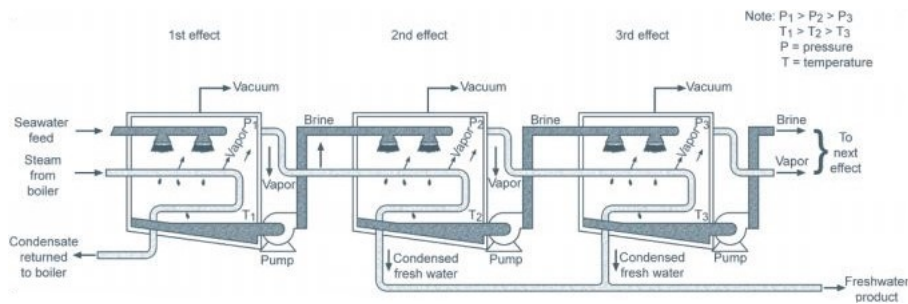

Figure 2.3: Multi-effect distillation process

small to medium volumes of fresh water and is mostly used to supply resorts, industries, and petroleum drilling sites [6].

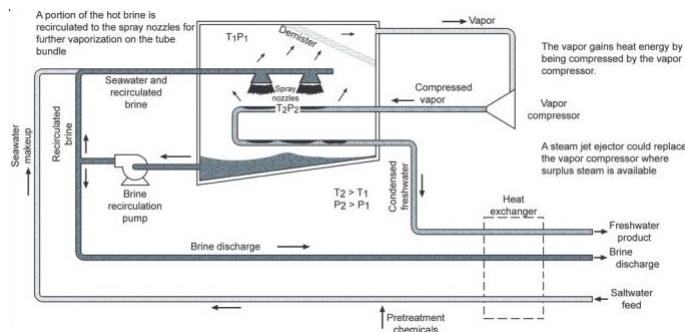

Figure 2.4: Vapor compression distillation process

### Solar desalination

The desalination process can be as simple as evaporating some water and condensing the vapors. This principle finds great usage in solar-powered desalters 2.5. Water vapors, created by solar radiation, are condensing on a clear cover and collected by side channels. Although this process is very simple, it's practically unusable for large productions. The large required area and a need for manual removal of the salt make it minor technology for water desalination [6].

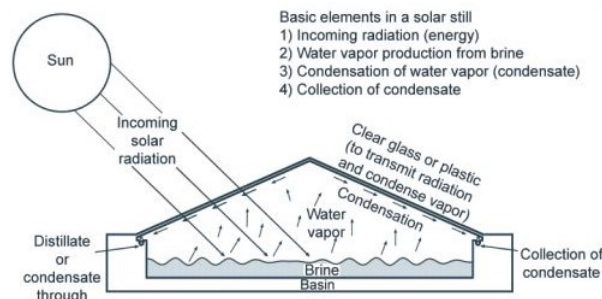

Figure 2.5: Example of a solar still desalination process

### 2.2.2 Membrane technologies

Membrane desalination processes use membrane as a physical barrier. The driving force can be electrical potential used in electrodialysis and electrodialysis reversal, or a pressure gradient, used in reverse osmosis. Membrane technologies often require pretreatment to limit blockage of membrane surface [6].

#### Electrodialysis and electrodialysis reversal

The membranes used in electrodialysis and electrodialysis reversal allow either positive or negative ions (atoms or molecules that have a net positive or net negative charge) to pass, but not both. Common ions in saline water are sodium, chloride, calcium, and carbonate. The membrane uses electrical potential to attract oppositely charged ions, producing fresh water on the other side. The electrodialysis reversal process works very similarly, the only difference being that the polarity or charge of the electrodes is switched periodically. It helps to remove scaling and other debris from the membranes thus extending the system's operating life [6].

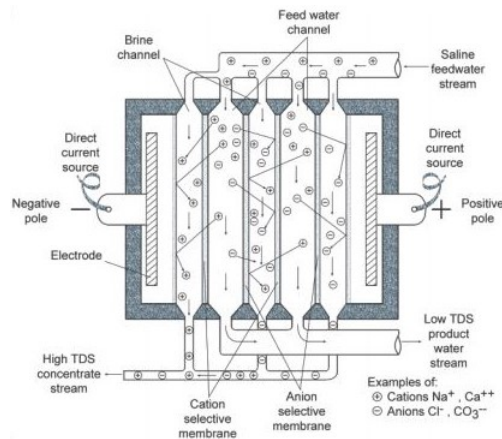

Figure 2.6: Example of an electrodialysis process

#### Reverse osmosis

Reverse osmosis uses a pressure gradient to move saline feed water through a membrane that prevents the salt ions from passing[6].

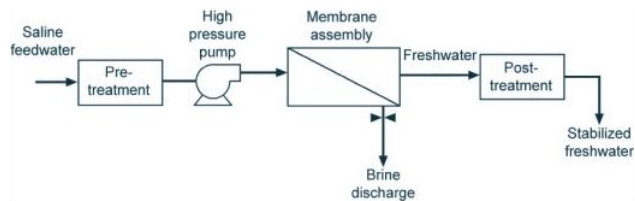
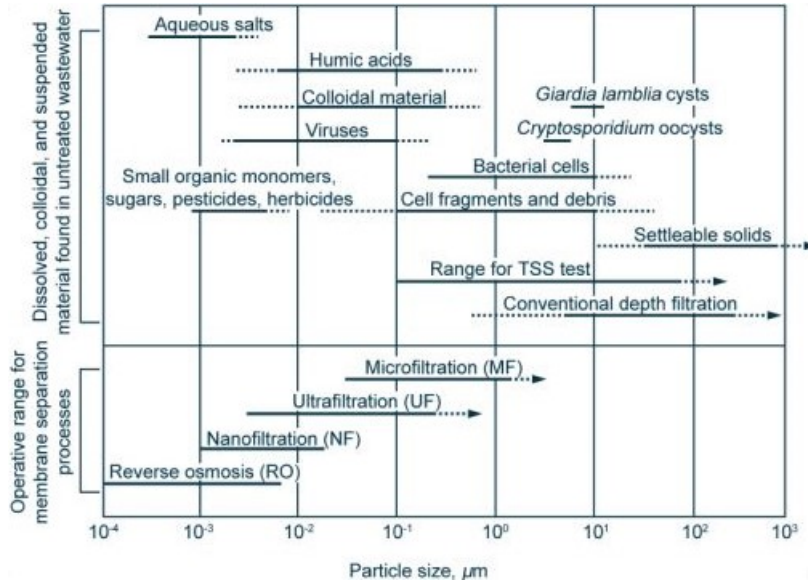

Figure 2.7: Basic components of membrane treatment process

There are several membrane treatment processes, including reverse osmosis, nanofiltration, ultrafiltration, and microfiltration. The pore sizes of the membranes differ according to the type of process[6].



**Figure 2.8:** Range of nominal membrane pore sizes for reverse osmosis, nanofiltration, ultrafiltration, and microfiltration

Due to the small pores in the RO membrane, water has to be pretreated, before passing through it. The pretreatment can be chemical, to prevent biological growth and scaling, or physical, to remove any suspended solids[6].

The RO membrane is constructed in a spiral pattern. There are layers of feed water and brine spacing, RO membrane, and a porous product water carrier wrapped around. Salty water is forced under high pressure to the feed water and brine spacing. The pressure gradient pushes the water through the RO membrane and the freshwater continues to the porous product water carrier. It allows the freshwater to flow to a product water tube, where it's collected[6].

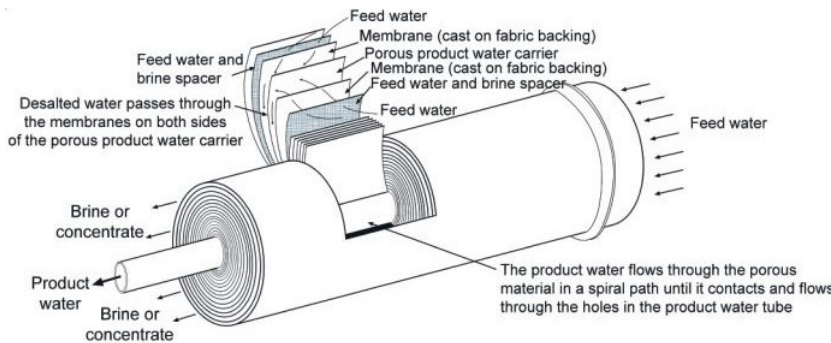

**Figure 2.9:** Cutaway view of a spiral reverse osmosis membrane element

To enable each pressure vessel to treat more water, the individual membrane elements are connected in series. The water passing through the membrane, it's too clean to be consumed. Post-treatment has to be done to make the product drinkable[6].

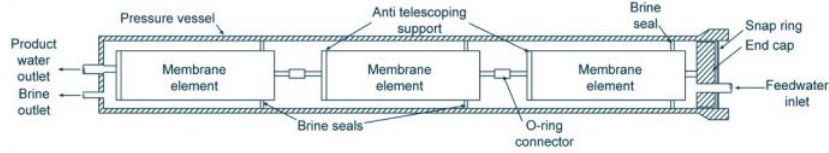

**Figure 2.10:** Cross section of a pressure vessel with three membrane elements

### 2.2.3 Ecology

The desalination process has a product and by-product stream. The product stream contains pure water with some dissolved solids and together they create produced freshwater. The by-product of desalination is called brine. It contains higher concentrations of dissolved solids and salts, some pretreatment additives, organics, microbial contaminants, and particulates rejected by RO membranes [15].

Brine disposal method	Principle and description	% of total capacity
Deep well injection	Brine is injected into porous subsurface rock formations	13
Land application	Brine is used for irrigation of salt-tolerant crops and grasses	8
Evaporation ponds	Brine is allowed to evaporate in ponds while the remaining salts accumulate in the base of the pond	4
Sewer discharge	Discharge of brine into an existing sewage collection system. Low in cost and energy	27
Seawater discharge; Surface	Brine is discharged on the surface of seawater. The most common method for all big desalination facilities worldwide	45
Seawater discharge; Submerged	Brine is discharged off shore through multipoint diffusers installed on the bottom of the sea	45

**Figure 2.11:** Most common brine disposal methods in the United States[15]

### Brine risks

Brine treatment can be quite problematic. It's usually being disposed back into the seawater which increases the salinity of the seawater near the desalination plant, negatively impacting the local marine life. It may also contain pretreatment and membrane cleaning chemicals, metals from the corrosion of the system (Cu, Fe, Ni, Mo, Cr) and other contaminates. The discharge pipes can impact nearby aquifers from leaks and creates permanent damage due to its infrastructure[15].

<i>Brine management method</i>	<i>Advantages</i>	<i>Disadvantages</i>
<i>Surface water discharge</i>	<ul style="list-style-type: none"> <li>• Can be used for all plant sizes</li> <li>• Cost effective for medium to large brine flow rates</li> </ul>	<ul style="list-style-type: none"> <li>• Brine may have negative impact in the aquatic ecosystem</li> <li>• Difficult and complex permit procedures</li> </ul>
<i>Sewer discharge</i>	<ul style="list-style-type: none"> <li>• Low construction and operation costs</li> <li>• Easy to implement</li> <li>• Low energy consumption</li> </ul>	<ul style="list-style-type: none"> <li>• Limited to small size brine flows</li> <li>• Potential adverse effects on WWTP operations</li> </ul>
<i>Deep well injection</i>	<ul style="list-style-type: none"> <li>• Suitable for inland desalination plants</li> <li>• Moderate costs</li> <li>• Low energy consumption</li> </ul>	<ul style="list-style-type: none"> <li>• Possible only if deep confined saline aquifer is available</li> <li>• Potential groundwater pollution</li> </ul>
<i>Evaporation ponds</i>	<ul style="list-style-type: none"> <li>• Easy to construct and operate</li> <li>• Inland and coastal use</li> </ul>	<ul style="list-style-type: none"> <li>• Limited to small brine flows</li> <li>• High footprint and costs</li> </ul>
<i>Land Application</i>	<ul style="list-style-type: none"> <li>• Easy to implement and operate</li> <li>• Inland and coastal use</li> </ul>	<ul style="list-style-type: none"> <li>• High footprint and costs</li> <li>• Limited to small plants</li> </ul>

**Figure 2.12:** Comparison of Brine Management Methods[15]

### ■ Brine disposal methods

The most common alternative is surface water discharge because it can be used in all sizes of desalination plants. Sewer disposal is very popular for small plants. A deep well injection is most suitable for medium and large island plants. Land evaporation ponds are often used where the climate and soil conditions provide high evaporation rates[15].





## Chapter 3

### Implementation

The first version of the board was created mainly to verify the working principles of the individual design blocks. Usually, most of the errors on the board is being created simply by inattention. Stuff like mismatched pinout of the components or inappropriate layout of the board is the most common. There were also several issues with the individual designs. My goal for this board was to repair all of these mistakes temporarily to prove the working concepts. In the end, I was able to successfully upload the firmware, measure some data on the real board and compare them to the simulations.

#### 3.1 Hardware

The hardware part of the board was designed with a focus on simplicity and durability. The device wasn't designed to be serviceable, so every fault would mean the replacement of the whole module. The rigidity of the system was supported by choosing parts, that could stand large amounts of abuse. There are a lot of discrete components used. The reason is that the discrete components can usually radiate much more heat, and can be measured individually during the design process.

##### 3.1.1 Mechanics

The board dimensions were chosen for the final product to fit a regular fuse box. When complete, it should be used as a click-up module. This way, it should be able to fit any regular electronic box. There would be also circuit breakers and contactors situated in the same box. This way, the design should be compact, safe, and good-looking. The device itself consists of two boards. The bottom board contains most of the electronics and the top board contains the user interface.

##### Layout

The layout of the board was defined by the position of the terminals. Individual blocks were situated to create short copper traces, especially the relay part of the board. The bottom board contains most of the electronics and

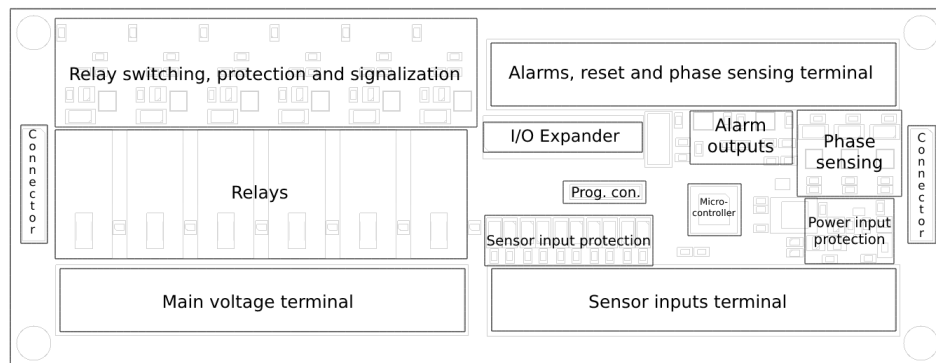

**Figure 3.1:** Layout of the functional blocks of the bottom board.

also one of the microcontrollers. The important function of this board is to protect the user from the main voltage. All of the power electronics, where the main voltage can be present are located here. This board is hidden in the fuse box with all the other power electronics and can not be accessed by the user while operated. There is also visual reasoning behind it. All the wires plugged into the wire terminals don't look good. This way it's all covered by the fuse box and the user sees just the top board.

The top board contains a user interface, which consists of an LCD, rotary

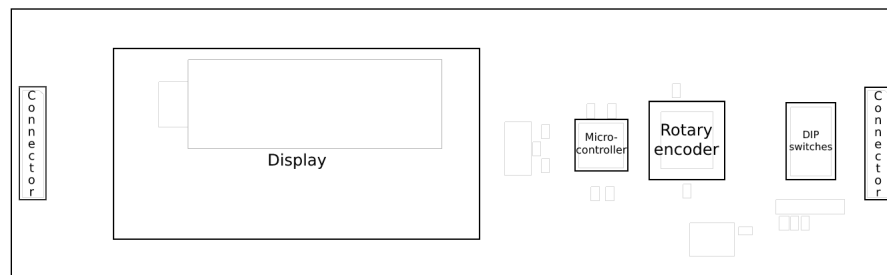

**Figure 3.2:** Layout the top board.

encoder, and DIP switches. The maximal voltage on this board is 5V DC, which is safe to touch. It's important because this part could be accessed by the user. There is a microcontroller and a couple of passive components on the backside of the board. Last but not least, there is a pair of connectors, which not only connects the boards but also serves as a mechanical spacer of the boards.

### ■ PCB characteristics

The choice of the materials used to produce the boards was forced by the production costs. The base material is 1.6mm FR-4, which is the most common material for PCBs. Both of the boards are 2-layer boards with 1oz thickness of copper layers. These specifications are perfectly usable for the top board, but the bottom board could have been better. There is a lot of

flex in the board when connecting wires to the terminals. The high current traces on the board could have a thicker layer of copper. It would result in lower temperatures of the traces while operating.

## ■ Housing

The device will be located in a fuse box. This fact also determines the physical dimensions. When I was creating this board, I looked up the dimensions of a typical circuit breaker as a reference for width and height. The length was determined by the size of the wire terminals and the number of accessories I need to connect to the board. It ended up being the size of 12 circuit breakers next to each other.

## ■ 3.1.2 Parts and components

Selecting the right parts for the board was the most time-consuming part of the whole project. They were chosen by a lot of criteria. Probably the biggest factor was the price. Cost reduction was one of the main goals of this project. I was also trying to use as few types of parts as possible to keep the populating costs down. Sadly the availability of all the electrical components is a huge issue today. Due to this reason, there have to be often compromised.

## ■ Display

For the display, I used an Eses I2C 20x4 LCD module. It's easy to use and I had a previous experience with it. The module contains the LCD and a PCF8574 8-bit I2C I/O expander which is used to save pins on the microcontroller. It's an alphanumeric display with 20 characters in a line and 4 lines.

## ■ DIP switches

DIP switches are manual switches grouped in one package. They are used to bypass the relay control circuits in case of service or failure.

## ■ Rotary encoder

A rotary encoder is a sensor of angular position. It's commonly used for all kinds of adjusting knobs, or as a sensor of rotation. It generates a digital signal, which is then processed in the microcontroller to determine the speed and direction of the rotation. I am using it to control the user interface. In combination with the push button, it provides all the necessary interfaces to navigate the menu and set all the parameters.

## ■ Terminals

I am using the TBL007A-500 terminal blocks. I chose those because, unlike screwing types, these are spring-loaded. There is a little metal spring, which



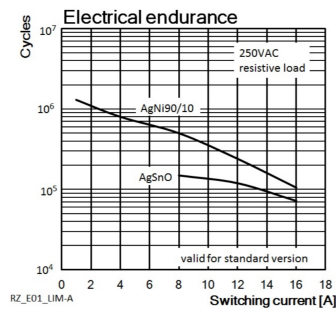

**Figure 3.3:** Estimated number of switching cycles [17]

When the relay tries to switch off the load, large arcs are generated, which damages the contacts faster [17].

### ■ Microcontroller

For the microcontroller, I chose ATmega328P. The main reason was, that I had previous experience with it. It's not ideal, but it has all the features I needed, and the fact, that I already know how to use it, allows much faster prototyping. ATmega328P is an 8-Bit microcontroller with a lot of features such as SPI and I2C interface, programmable watchdog timer, and external and internal interrupt sources. The biggest disadvantage is, that the microcontroller is basically unavailable and I will have to find a fitting replacement in the future. [18].

### ■ Optocouplers

I am using optocouplers either to separate the main voltage from the low voltage DC circuits or to create so called dry contacts (contacts, that have no electrical potential and can be only connected or unconnected). Optocoupler is LED and photo-transistor in one package. When current starts to pass through the diode, the light is emitted to the photo-transistor and it starts to conduct current. Both of the circuits remain electrically separated.

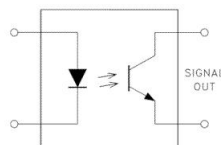

**Figure 3.4:** Optocoupler [19]

### ■ Power supply

Firstly I was planning to design my own power supply directly on the board. After some research, I decided to use an external power supply. There were a couple of reasons to do it that way. Mainly I did not find a way to create a

safe and reliable power supply, that will be cheaper than those already on the market. On top of that, there will be much more trouble dealing with the electromagnetic compatibility of the board.

### 3.1.3 Working principles

#### Power input protection

I started by looking for some power protection IC, but I couldn't find any to fit my needs. The problem was the input voltage range. Usually, the maximum input voltage was around 20V. My goal was to have input protection, that could withstand connecting the main voltage. So I tried to design one by myself. The main transistor (Q7) is normally opened. When the voltage

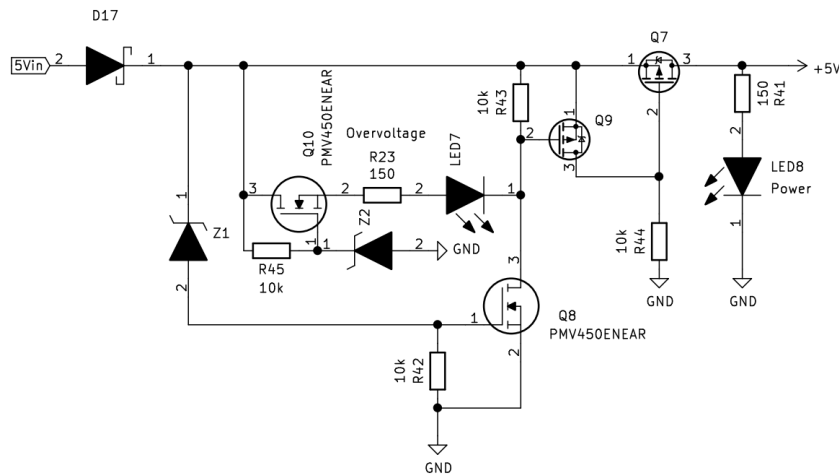

Figure 3.5: Power input overvoltage protection schematic

passes a set limit, the Zener diode (Z1) will start to conduct current. This current creates a voltage drop on R42 and opens transistor Q8. Q8 pulls the gate of Q9 to the ground. Q9 opens and the current starts flowing through R44. This way the Q7 closes and cuts the power from the board. Transistor Q10 is used as a voltage regulator for LED7, which signals the overvoltage.

Unfortunately, I forgot, that there is a maximal gate-source voltage for every transistor. It's usually about 20V and in case of overvoltage, the gate-source voltage on Q7, Q8, and Q9 is almost the input voltage. That limits the usability of this protection to around 20V, which is almost the same as the commercial ICs.

#### Sensor input protection

Logic inputs are protected using pair of diodes connected between 5V and GND. There is 1k resistor to limit diode current. The maximal average current for the diodes is 1A. This way, it can theoretically protect the device up to

1000V. The limitation is the resistor. I am using 0805 resistor size, which can typically handle around 1/8W. The maximal voltage can be calculated according to the formula

$$P_{max} = V_R I \quad (3.1)$$

$$I = V_R / R \quad (3.2)$$

$$P_{max} = V_R^2 / R \quad (3.3)$$

$$V_R = \pm \sqrt{P_{max} R} \quad (3.4)$$

$$V_R \doteq 11V \quad (3.5)$$

$$V_{in} = V_R + V_D + 5V \quad (3.6)$$

$$V_{in} \doteq 17V \quad (3.7)$$

The resistor and capacitor together forms low-pass filter to protect the circuit against voltage spikes. The cutoff frequency can be calculated as

$$f_c = \frac{1}{2\pi RC} \quad (3.8)$$

$$f_c \doteq 1600Hz \quad (3.9)$$

which is more than enough for all the analog sensors. Sadly, I had to remove the protections low pass filter for the digital sensors.

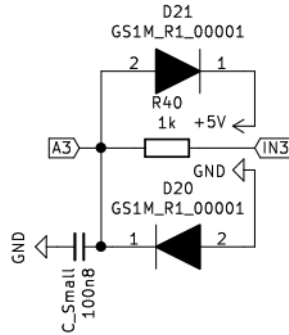
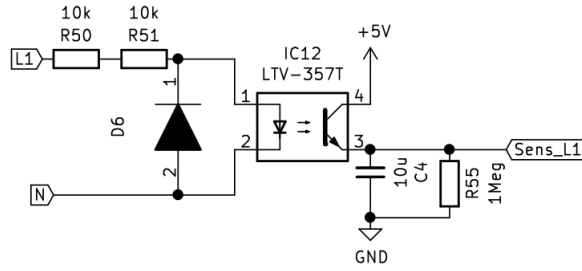

**Figure 3.6:** Sensor input overvoltage protection schematic

### ■ Phase sensing

I am using optocouplers to sense if all three phases of the main voltage are connected. The optocoupler LED is connected between live wire and neutral wire. The current through the diode is limited by the resistor R50 and R51. We can calculate the maximum current  $I_{max}$  passing through the diode according to the formula

$$I_{max} = \frac{(V_{max} - U_D)}{R_{50} + R_{51}}. \quad (3.10)$$

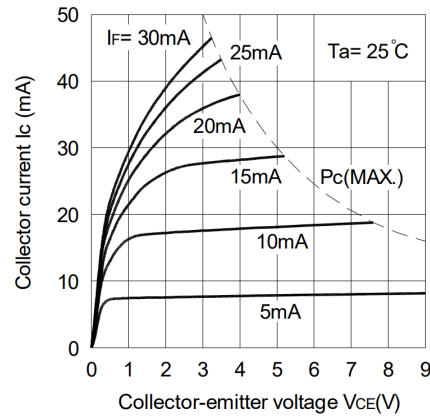

**Figure 3.7:** Phase sensing circuit schematic

We can find the  $V_D$  in the data sheet of the optocoupler [20]. For  $V_D = 1.2V$  and  $V_{max} = 330V$  we can assume  $V_{max} - V_D \doteq V_{max}$ .

$$I_{max} = \frac{(330)}{20 \cdot 10^{-3}} = 16.5mA \quad (3.11)$$

We can find the collector current according to a the graph in data sheet [20]. As we can see, the peak collector current is about 30mA.



**Figure 3.8:** Collector current vs. collector-emitter voltage[20]

Another parameter, we have to take care of is the maximal reverse voltage of the diode  $V_r = 6V$ . In the negative half-wave, the voltage on the diode would be 330V. That is why there is a diode D6 connected antiparallel. It keeps the reverse voltage at 0.7V.

### ■ Relay switching

The I/O pins of the microcontroller can't supply enough current to power the coils of the relays. Therefore it's necessary to use transistors to do that. In this case N-channel MOSFETs.

The relay coil is basically an inductor. If I try to rapidly disconnect the relay coil magnetic field inside the inductor forces the current to keep flowing. This creates a large voltage spike, at the contacts of the coil. The voltage



can be so high, that it could damage the MOSFET. That's why there is an antiparallel diode connected. When the MOSFET turns off, the diode leads the current back to the +5V rail and protects the MOSFET from damage.

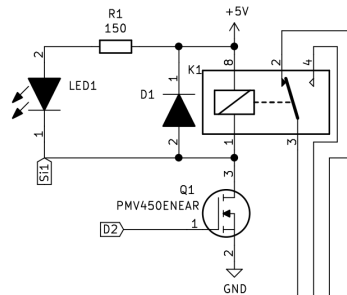

**Figure 3.9:** Relay switching circuit

The LED is used just to inform the user if the relay is on or off.

There is a Si1 netlabel in the schematic. That's where the DIP switch on the top board is connected. The switch is connected parallel to the MOSFET. In case of maintenance or failure, the user can control the relays manually using the switches.

### External alarms

The board can be connected to an external GSM alarm. It can difference between two priorities of alarms. The GSM has two outputs, which sends out the alarm signal when shorted. I am using optocouplers to do that. The resistor R48 protects the phototransistor from damage in case of shorted output. There is an LED, showing the current state of the alarms.

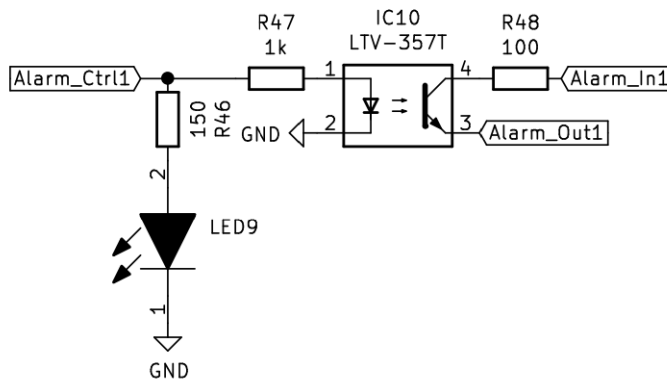

**Figure 3.10:** Alarm output schematic

### Zero crossing sensing

I implemented a zero-tracking system, to prevent arcing between the contacts of the relay, due to the inductive load. It senses the passing current and turns off the relay when the sinusoidal cross the zero. This way, there is no current passing through the inductor and therefore there are no arcs between the contacts.

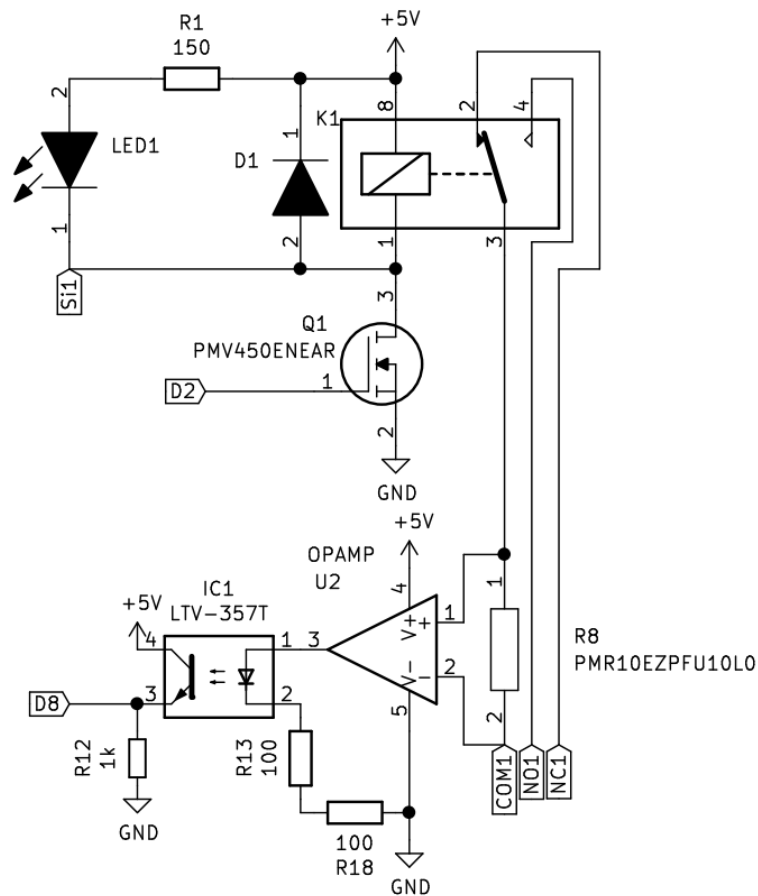

Figure 3.11: Relay schematic

The passing current creates a voltage drop at resistor R8. The voltage difference is sensed by the operational amplifier. It's being used as a comparator. When the direction of the passing current changes, the polarity of the voltage drop on the resistor also changes. It generates a rising or falling edge at the output of the comparator which can be then processed. The output of the comparator is isolated from the rest of the circuit by an optocoupler.

## 3.2 Firmware

I designed my own firmware for this board. Its main task is to manage the production process, collect and evaluate data from sensors, and provide a user interface. It was written in C++ programming language. During the designing process, I used a lot of libraries, mostly to control the external peripherals of the microcontroller.

### 3.2.1 Production process

The production process was provided to me by the company, I am designing the board for. The production consists of several steps. When the water level sensor senses a low level in the water tank the backwashing process starts. It's necessary to wash out the debris from the membranes before the production starts. Then the low-pressure pump starts. It primes the system with seawater. The pressure in the system needs to get to a set value, before starting the high-pressure pump. The production continues until the tank isn't full. If the production takes longer than 30 minutes, the process is interrupted by a backwashing sequence, and then it starts all over again.

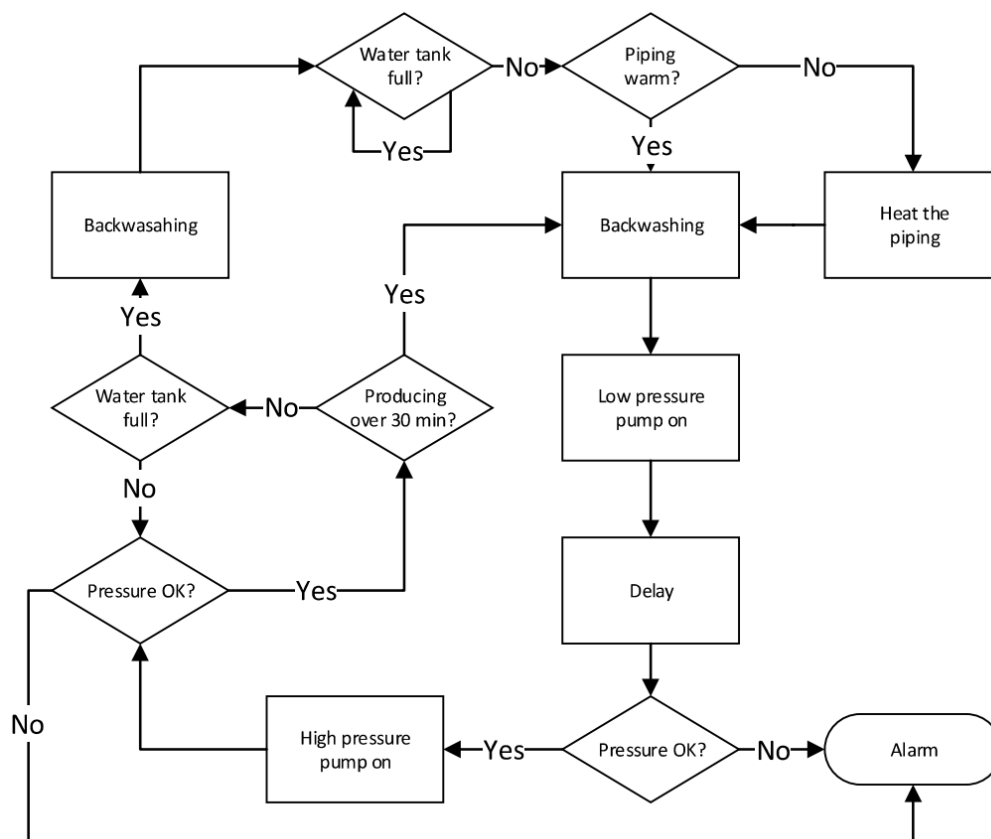

Figure 3.12: Production diagram

There are two microcontrollers on the board. The microcontroller on the bottom board takes care of the relay switching and evaluates the data from the sensors. The microcontroller on the top board manages the user interface. They communicate using the I2C protocol. The top microcontroller sends information about the current settings and the bottom one sends the sensor data to be shown on the display. The current settings are updated before every production step, and the sensor data are sent periodically every second.

### 3.2.2 User interface

The user interface is provided by an LCD and rotary encoder located on the top board. It allows the user to change all of the important parameters of the system. It also provides information about the current system status and shows the current temperature and pressure in the system.

#### Main screen

The main screen is shown most of the time. It shows the current temperature and pressure and the system status. I am using an internal timer, to refresh main screen data periodically.

#### Menu

The production process can be changed to fit local conditions. It's can be done by the serviceman while installing or maintaining the unit. Most of the settings shouldn't be accessed by the user, because it can cause instability of the system, failure, or damage. For this reason, most of the settings will be protected by password in the future.

## 3.3 Second version

After testing the first version of the board, I decided on creating a second, updated prototype. The goal of it was to fix all the errors on the first board, implement some design changes, reduce the costs and simplify the design.

### 3.3.1 Hardware

Most of the hardware changes were fixing errors caused by inattention. I usually already fixed them temporarily on the first board to prove the concept and avoid mistakes on the second version.

#### Mechanics

The layout of the board remained very similar to the first prototype. The biggest mechanical change was replacing the 30mm connectors with spacer studs. It made the board more rigid and reduced the chance of damaging the

connectors during installation or maintenance. The electrical function of the connectors was replaced by 14 pin headers, connected by flat wires.

### ■ Parts and components

The 30mm pin headers used to connect the two boards were replaced by 14 pin headers, connected by flat wires. I also added a DC jack to connect the power supply.

In this version, I used four 25mm spacer studs to mechanically connect the boards. They also serve as ground connections. Studs come in a much wider range of sizes, which gives me better control of the module dimensions.

I changed the I/O Expander for MCP23008T simply because I can get it in the SMD package. This way, the populating of the board is much easier.

### ■ Working principles

I changed the original power input protection for an MP5018GD integrated circuit. This way I saved production costs, added features like short circuit and undervoltage protection, and simplify the populating of the board.

I decided not to use the zero-sensing system on the board. I had a lot of trouble with it on the first prototype and I never get it to work properly. It might be added in the future.

### ■ 3.3.2 Software

The biggest change on this board is, that it uses only one microcontroller. It helped to simplify the coding process. There are now two threads running on the microcontroller. An internal timer switches the threads between one and another. One thread takes care of the user interface, while the other manages the production and evaluates the data from sensors.





## Chapter 4

### Conclusion

In this bachelor thesis, I described the processes used for water desalination. I studied the desalination technologies used around the world. I described thermal technologies as multi-stage distillation, multi-effect distillation, vapor compression distillation, and solar distillation. I paid special attention to membrane technologies such as electrodialysis, electrodialysis reversal, and most importantly reverse osmosis. I also discussed the ecological aspect of desalination and described the risks associated with brine disposal.

The main focus of my project was to develop a device, which will control the production process of the desalination unit. After deciding the functions of the board, I started the part-picking process. Simultaneously I started to develop the PCB. The design aimed to create a module, which can be easily fitted to any fuse box. That determined the dimensions of the PCB. The control unit, currently used on the desalters, used discrete relays and timers to control the process. That wasn't only expensive, but also doesn't offer many options for settings. I designed a system controlled by a microcontroller. I used LCD and rotary encoder to provide a user interface and relays to control the outputs of the board. I also designed a firmware, which evaluates data from the sensors and controls the production process. This way, I was able to add a lot of additional functions. Using the low-power electronics, I was able to cut the production costs rapidly.

During the testing of the first prototype, I run into several issues. I managed to repair most of them temporarily to be able to prove the conceptual design. I was also able to successfully test the firmware for the board. For the second prototype, I fixed all the original issues and added some improvements.

The second prototype is currently in the stage of testing, but no major issues were found. I am planning to finish the firmware development on it. I will produce three to five units for real-life testing in the following months. These units will be used in desalters to fine-tune the software and hardware and primarily to find all the hidden issues before producing any larger series.





## Bibliography

- [1] BRTNÍK, Bohumil. *Teoretická elektrotechnika*. Praha: BEN - technická literatura, 2017. ISBN 978-80-7300-547-4.
- [2] Water Science School. Desalination. *USGS: science for changing world* [online]. September 11, 2019 [cit. 2022-05-04]. Available: [https://www.usgs.gov/special-topics/water-science-school/science/desalination?qt-science\\_center\\_objects=0#qt-science\\_center\\_objects](https://www.usgs.gov/special-topics/water-science-school/science/desalination?qt-science_center_objects=0#qt-science_center_objects)
- [3] Freshwater Availability. In: *National Geographic Society* [online]. [cit. 2022-05-04]. Available: <https://media.nationalgeographic.org/assets/photos/000/316/31664.jpg>
- [4] Example of a solar still desalination process. In: *Texas A&M Agrilife extension* [online]. [cit. 2022-05-05]. Available: <https://cdn-ext.agnet.tamu.edu/wp-content/uploads/2019/04/figure-307-example-of-a-solar-still-desalination-process.jpg>
- [5] The Editors of Encyclopedia Britannica. Desalination. Britannica [online]. [cit. 2022-05-05]. Available: <https://www.britannica.com/technology/desalination>
- [6] MECHELL, Justin K. and Bruce LESIKAR. *Desalination Methods for Producing Drinking Water* [online]. [cit. 2022-05-05]. Available: <https://agrilifeextension.tamu.edu/library/water/desalination-methods-for-producing-drinking-water/>
- [7] Multi-stage flash desalination process. In: *Texas A&M Agrilife extension* [online]. [cit. 2022-05-05]. Available: <https://cdn-ext.agnet.tamu.edu/wp-content/uploads/2019/04/figure-304-example-of-multi-stage-flash-distillation.jpg>
- [8] Multi-effect distillation process. In: *Texas A&M Agrilife extension* [online]. [cit. 2022-05-05]. Available: <https://cdn-ext.agnet.tamu.edu/wp-content/uploads/2019/04/figure-305-example-of-multi-effect-distillation.jpg>

- [9] Vapor compression distillation process. In: *Texas A&M Agrilife extension* [online]. [cit. 2022-05-05]. Available: <https://cdn-ext.agnet.tamu.edu/wp-content/uploads/2019/04/figure-306-example-of-a-vapor-compression-distillation-process.jpg>
- [10] Example of an electrodialysis process. In: *Texas A&M Agrilife extension* [online]. [cit. 2022-05-05]. Available: <https://cdn-ext.agnet.tamu.edu/wp-content/uploads/2019/04/figure-308-example-of-an-electrodialysis-process-showing-the-basic-movements-of-ions-in-the-treatment-process.jpg>
- [11] Basic components of membrane treatment process In: *Texas A&M Agrilife extension* [online]. [cit. 2022-05-05]. Available: <https://cdn-ext.agnet.tamu.edu/wp-content/uploads/2019/04/figure-310-basic-components-of-a-membrane-treatment-process.jpg>
- [12] Range of nominal membrane pore sizes for reverse osmosis, nanofiltration, ultrafiltration, and microfiltration In: *Texas A&M Agrilife extension* [online]. [cit. 2022-05-05]. Available: <https://cdn-ext.agnet.tamu.edu/wp-content/uploads/2019/04/figure-311-range-of-nominal-membrane-pore-sizes-for-reverse-osmosis.jpg>
- [13] Cutaway view of a spiral reverse osmosis membrane element In: *Texas A&M Agrilife extension* [online]. [cit. 2022-05-05]. Available: <https://cdn-ext.agnet.tamu.edu/wp-content/uploads/2019/04/figure-312-cutaway-view-of-a-spiral-reverse-osmosis-membrane-element.jpg>
- [14] Cross section of a pressure vessel with three membrane elements In: *Texas A&M Agrilife extension* [online]. [cit. 2022-05-05]. Available: <https://cdn-ext.agnet.tamu.edu/wp-content/uploads/2019/04/figure-313-cross-section-of-a-pressure-vessel-with-three-membrane-elements.jpg>
- [15] Brine Treatment. *Lenntech* [online]. [cit. 2022-05-09]. Available: <https://www.lenntech.com/processes/brine-treatment.htm>
- [16] *GS1A\_SERIES-1870165* [online]. [cit. 2022-05-11]. Available: [https://cz.mouser.com/datasheet/2/1057/GS1A\\_SERIES-1870165.pdf](https://cz.mouser.com/datasheet/2/1057/GS1A_SERIES-1870165.pdf). Datasheet.
- [17] *ENG\_DS\_RZ\_0920-736212* [online]. [cit. 2022-05-11]. Available: [https://cz.mouser.com/datasheet/2/418/6/ENG\\_DS\\_RZ\\_0920-736212.pdf](https://cz.mouser.com/datasheet/2/418/6/ENG_DS_RZ_0920-736212.pdf). Datasheet.
- [18] *megaAVR® Data Sheet*[online]. [cit. 2022-05-11]. Available: [https://cz.mouser.com/datasheet/2/268/ATmega48A\\_PA\\_88A\\_PA\\_168A\\_PA\\_328\\_P\\_DS\\_DS40002061B-1900559.pdf](https://cz.mouser.com/datasheet/2/268/ATmega48A_PA_88A_PA_168A_PA_328_P_DS_DS40002061B-1900559.pdf). Datasheet.

- [19] Optocoupler In: *jestineyong.com* [online]. [cit. 2022-05-11]. Available: <https://www.jestineyong.com/wp-content/uploads/2009/06/optoic.jpg>
- [20] *Photocoupler Product Data Sheet*[online]. [cit. 2022-05-11]. Available: [https://cz.mouser.com/datasheet/2/239/LTV-357T\\_series\\_RevP-1543500.pdf](https://cz.mouser.com/datasheet/2/239/LTV-357T_series_RevP-1543500.pdf). Datasheet.





## Appendix A

### List of Notation

Symbol	Meaning
$P_{max}$	Maximum dissipated power
$V_R$	Voltage on resistor
$I$	Current
$R$	Resistance
$V_{in}$	Input voltage
$V_D$	Voltage on diode
$F_c$	Cutoff frequency
$C$	Capacity
$I_{max}$	Maximum current
$V_{max}$	Maximum voltage
$V_r$	Reverse voltage