



**CZECH TECHNICAL
UNIVERSITY
IN PRAGUE**

F3

**Faculty of Electrical Engineering
Department of Control Engineering**

Bachelor's Thesis

Open Rapid Control Prototyping, Education and Design Tools

Dion Beqiri
beqirdio@gmail.com

May 2022
Supervisor: Ing. Pavel Píša, Ph.D.

I. Personal and study details

Student's name: **Beqiri Dion**

Personal ID number: **480810**

Faculty / Institute: **Faculty of Electrical Engineering**

Department / Institute: **Department of Control Engineering**

Study program: **Electrical Engineering and Computer Science**

II. Bachelor's thesis details

Bachelor's thesis title in English:

Open Rapid Control Prototyping, Education and Design Tools

Bachelor's thesis title in Czech:

Nástroje pro podporu návrhu řídicích aplikací pro výuku a prototypování

Guidelines:

The need to develop quickly and user friendly control systems is growing. Education and industry would gain from solutions which allows complete introspection not only of generated code but even of complete tool-chain. Open, extensible and freely accessible solution is win for education, industry and enthusiasts.

Combination of NuttX RTOS and pysimCoder project has potential to take this role for constrained MCU based systems and GNU/Linux with fully preemptive kernel for larger ones. Both provide POSIX API so porting is and developing for both i possible.

- 1) Familiarize with pysimCoder, NuttX and GNU/Linux
- 2) Test and document setup for more simpler plans control (DC motor, the ball on the beam)
- 3) Test/extending device support to ESP32-C3 and Xilinx Zinq based MZ_APO education kits
- 4) Extend pysimCoder for vector support and and optionally even different data types of signals
- 5) Reuse of blocks and mechanisms in other OS (Linux)
- 6) Demo of achieved Results, by controlling some peripheral using pysimCoder and NuttX
- 7) Documenting results and setups for educational purposes

Bibliography / sources:

- 1) Bucher, R.: Python for Control Purposes, <http://robertobucher.dti.supsi.ch/wp-content/uploads/2017/03/BookPythonForControl.pdf>
- 2) pysimCoder, GitHub <https://github.com/robertobucher/pysimCoder>
- 3) NuttX, GitHub <https://github.com/apache/incubator-nuttX>
- 4) NuttX, Documentation <https://nuttX.apache.org/docs/latest/>
- 5) Lenc, M.: Google Summer of Code 2021, NuttX Support for Rapid Control Applications Development with pysimCoder <https://summerofcode.withgoogle.com/projects/#4867567685992448>

Name and workplace of bachelor's thesis supervisor:

Ing. Pavel Piša, Ph.D. Department of Control Engineering FEE

Name and workplace of second bachelor's thesis supervisor or consultant:

Date of bachelor's thesis assignment: **10.09.2021** Deadline for bachelor thesis submission: **20.05.2022**

Assignment valid until: **19.02.2023**

Ing. Pavel Piša, Ph.D.
Supervisor's signature

prof. Ing. Michael Šebek, DrSc.
Head of department's signature

prof. Mgr. Petr Páta, Ph.D.
Dean's signature

III. Assignment receipt

The student acknowledges that the bachelor's thesis is an individual work. The student must produce his thesis without the assistance of others, with the exception of provided consultations. Within the bachelor's thesis, the author must state the names of consultants and include a list of references.

Date of assignment receipt

Student's signature

Acknowledgement / Declaration

First and foremost, I would like to thank my supervisor for his extensive support and mentorship during my journey.

I would also like to thank my colleagues for all the great conversations while we were working on our theses.

Lastly, I would like to thank all my family and friends which have believed in me throughout my academic path...

I declare that the presented work was developed independently and that I have listed all sources of information used within it in accordance with the methodical instructions for observing the ethical principles in the preparation of university theses.

In Prague 20. 5. 2022

.....

Abstrakt / Abstract

Control systems engineering plays a crucial role in the rapid development of human technology, hence the demand for more user friendly and open-source tools for systems design is significantly growing. PysimCoder is a Rapid Prototyping Control application, which can be used to graphically design control systems schematics for the purpose of generating real time code for different targets. Its main advantages are that it is freely available, open source, and it supports both NuttX RTOS and GNU/Linux targets, all of which enhance the educational experience.

The pysimCoder application is far from being mature, however the further extension of the project could be a great win for education, industry, and recreation. The main goals of this thesis will be focused on adding new features to the project, such as support of vector signals, as well as device support for the ESP32C3 (using NuttX RTOS) and Xilinx Zynq based MZ_APO education kits (using GNU/Linux). Throughout this document there will be demonstrations of each extension that was added, as well as full descriptions of the approaches used to implement them.

Contents /

1 Introduction	1	4.2 pysimCoder for Raspberry Pi Target	25
2 PysimCoder	2	4.2.1 Hardware Introduction	25
2.1 Introduction to the PysimCoder Tool	2	4.2.2 Existing Simulink Project and Adaptation to pysimCoder	27
2.1.1 Control Systems and their Design Tools	2	4.2.3 Demonstration of Results	27
2.1.2 PysimCoder: Control Systems Design and Code Generation Tool	3	5 Testing and Extending NuttX RTOS Support in pysimCoder	30
2.2 Code Generation Path of pysimCoder	4	5.1 NuttX RTOS	30
2.2.1 Graphical User Interface of pysimCoder	4	5.1.1 Introduction	30
2.2.2 Source Code of pysimCoder	5	5.1.2 Existing Support in pysimCoder	31
3 Vector Support	8	5.2 ESP32C3 Board with NuttX RTOS	31
3.1 Vectors in Control Systems	8	5.2.1 Hardware Introduction	31
3.2 Basic Implementation of Vectors in pysimCoder	10	5.2.2 Installing NuttX RTOS on ESP32C3	32
3.2.1 Method of Approach	10	5.2.3 Enabling and Testing pysimCoder on ESP32C3	34
3.2.2 Changes in Python Source and Generated C-code	10	5.3 Demonstration of Control using ESP32C3 with NuttX and pysimCoder	35
3.2.3 New Blocks for Vector Testing	12	5.3.1 Hardware Requirements	35
3.2.4 Demonstration of Basic Vector Support (Static Dimension Setting)	13	5.3.2 Adaptation of RaspberryPi Project	36
3.3 Vectors with Dynamic Dimension-setting Algorithm	14	5.3.3 Demonstration of Simple PMSM Motion Control with ESP32C3	39
3.3.1 Method of Approach	14	6 Conclusion	41
3.3.2 Development of Algorithm	14	A Source Code	43
3.3.3 Changes in Source Code	16	A.1 Vectors	43
3.3.4 Demonstration of Automated Dimension Setting	18	A.2 Linux Targets	43
4 Extending Support of GNU/Linux Targets in pysimCoder	19	A.3 NuttX Targets	43
4.1 PysimCoder for Xilinx Zynq Based MZ_APO Kit	19	B Glossary	44
4.1.1 Hardware Introduction	19	References	46
4.1.2 Existing Simulink Project	21		
4.1.3 Integration with pysimCoder	21		
4.1.4 Demonstration of Results	23		

/ Figures

2.1	PysimCoder's front-end GUI	4
2.2	PysimCoder's Code Generation path	6
3.1	Vector represented in 3D space	8
3.2	Block diagram schematic for control system	9
3.3	Necessary code/files for pysimCoder block	10
3.4	Math operations on vectors in pysimCoder GUI	13
3.5	Demux-Mux test in pysimCoder GUI	14
3.6	Algorithm for automatic setting of dimensions of vector blocks	16
3.7	Vector blocks with dimensions set automatically	18
4.1	MZ_APO Educational Kit Zynq based board hardware	20
4.2	Hardware setup for DC motor follower with PID on Zynq	23
4.3	PysimCoder diagram for DC motor follower with PID on Zynq	24
4.4	RaspberryPi Model 2B v1.1	25
4.5	Hardware setup for PMSM control w/ RPi board	26
4.6	PysimCoder diagram for motion control of 3-Phase Motor	28
4.7	Graph of PMSM motion control example with RaspberryPi	29
5.1	ESP32C3-DevKitM-1 board presentation	32
5.2	PMSM motion control with ESP32C3 board	36
5.3	Pin assignment of PMSM motion control with ESP32C3 board	37
5.4	PysimCoder diagram for PMSM motion control with ESP32C3 board	40

Chapter 1

Introduction

Today we live in a heavily automated world, where almost every industry is reliant upon multiple complex control systems. In fact, the rate at which technology is developing is very related to our ability to control and automate the processes around us. Considering the importance of this field, the need for more control tools and engineers is becoming apparent. At the time, there are already many tools which are used for designing real control systems, such as Simulink, XCos, LTSpice, OpenModelica, CODESYS, and many more.

Freely available and open-source programs are the future, therefore having control systems tools which meet these requirements is beneficial for industry, education, and enthusiasts. One program which complies with this idea is `pysimCoder`, a graphical control systems design tool which can generate code for microcontroller units. The application is far from its paid counterparts in terms of development. Nevertheless its open source nature allows anyone to extend the program, and is very useful for educational purposes. `PysimCoder` will be the heart of my thesis work, since the main goals are related to enhancing and extending the features of the tool. The full description of the application and its source code can be read in chapter 2.

In order to fulfill the requirements of this thesis, my work will revolve around three main features to be added. These will be to add vector support for the signals, to extend the support for different hardware running on LinuxOS, as well as to test and enhance the support for NuttX RTOS using a RISC-V architecture board.

Vectors are a topic that even children learn in school, due to their very wide usage in various fields of mathematics. Most technical fields will use vector mathematics for one purpose or another, including even control engineering. Therefore having the ability to work with vectors in `pysimCoder` will be very useful, especially in terms of mathematical operations. In chapter 3 it will be explained not only why, but also how this feature can be implemented.

In `pysimCoder`, it is already possible to generate code for real-time Linux targets. Nevertheless, a lot of the code necessary for microcontroller hardware operations will be specific to the hardware being used. In the case of the MZ_APO educational kit, full support will be added from scratch, due to its previous nonexistence. The RaspberryPi already has support, however it will be extended for 3-phase motor control demonstration. The hardware and software necessary for these implementations will be covered in chapter 4.

NuttX is a real-time operating system (RTOS) which is developed mainly for small and constrained MCU environments. Using the NuttX blocks in `pysimCoder`, it will be possible to test a control system on a RISC-V based board such as the ESP32C3 development kit. In chapter 5, I will explain how the work done for the RaspberryPi extension can be used to demonstrate motion control of a 3-Phase motor, even using a small board with weaker capabilities.

Chapter 2

PysimCoder

All of the work done towards the completion of this thesis is related to the PysimCoder project. Considering this the program must be fully explained, from the user interface perspective, as well as the source code perspective. This will help to better understand any of the implementations covered in the succeeding chapters.

2.1 Introduction to the PysimCoder Tool

2.1.1 Control Systems and their Design Tools

“A control system is an interconnection of components forming a system configuration that will provide a desired system response.”[1, chapter 1]

We as a species have thrived upon the idea of controlling the processes around us. Of course, there are many natural occurrences that we cannot prevent nor avoid (yet), however we still maintain an increasing ability to control and automate all types of processes that can be used to our benefit. This concept of automated control systems has become the engine behind the rapid development of human technology, and concurrently has changed the way humans live and function as a society.[1] Therefore, as our technology advances further and faster, the necessity for automation solutions and engineers will only grow with it.

Due to the wide range of industries and fields which rely heavily on automation, there are various solutions and tools which offer the ability to design, simulate, and control real time systems. The software which is used all depends on the application and hardware which is being targeted. In an industrial setting, one would probably use TIA Portal [2] or CODESYS [3] to program the controllers of some production line in a factory. For designing and simulating complex electrical circuits, AutoDesk Fusion360 [4] would be a perfect environment for high accuracy and modern solutions, while LTspice [5] is more useful for simpler analog circuits.

For many fields of engineering, there is a corresponding software which is used for control design of a certain type of system, however for the purpose of this thesis I will focus on solutions which are meant for mathematical simulations, and code generation for microcontroller units. These include programs such as MATLAB and Simulink, which make up a very elaborate tool for designing a system controlled by a microprocessor unit, and for visualizing the data coming from the physical system in real-time. In essence, Simulink is a graphical tool for creating block diagram schematics which represent a particular system using mathematics. Furthermore, users of Simulink can create their own blocks, not only for mathematical calculations, but even for control of physical hardware. Using this feature, one can combine the mathematical blocks with hardware-related blocks in order to generate binary code for execution on a MCU, which can then control different types of hardware connected to it. [6]

■ 2.1.2 PysimCoder: Control Systems Design and Code Generation Tool

Another such tool is PysimCoder, which has been the focal point of my diploma work. Started and developed by professor Roberto Bucher from the University of Applied Sciences and Arts of Southern Switzerland, PysimCoder is an open-source graphical tool used for real-time code generation, typically for microcontrollers and PCs which are controlling some physical peripherals. Additionally, it can also be used as a simulation tool for simple control schemes. Target operating systems include GNU/Linux with or without preemptive-rt kernel, and NuttX RTOS usually for constrained MCU based systems. At its core, it is a Rapid Prototyping Control application, similar in style to programs like Simulink and XCos.[7] This application is still under development, and it has nowhere near the amount of investment or resources that its alternatives use. Nevertheless, this application has some advantages which should be considered for a control system tool, and thanks to its small size and user-friendly interface it can be an ideal starting point for educational purposes in the topic of control systems.

Firstly, it is open-source and freely accessible, which allows complete introspection of the generated code, as well as the source code of the application itself. This way, if there is an error or an issue during usage, anyone with a good knowledge of programming can go inside the source and fix the bugs as needed. Another great advantage is that it takes much less memory space, which results in faster installation and overall usage. At the current moment, the whole project takes up about 100MB of space on my hard drive, which is negligible compared to the many gigabytes of space which Simulink requires. This is immediately noticed when comparing loading times between the two.

Probably the best thing about this program is that it uses Python as a programming language for most of the core functions. Using many Python libraries which are specialized in control systems mathematics, the application is able to design a schematic on a source code level. The program can translate this design into C programming language, which can ultimately be compiled and deployed to a MCU as machine code. The combination of Python and C languages is perfect for easy deployment in most environments, both for the host running PysimCoder, and for the target running the generated code. [7, chapter 8]

PysimCoder is originally set up for installation in a Linux OS environment, however due to the many virtualization and containerization techniques used in computers today, the program can even be run in Windows OS, or Mac OSX [7, chapter 8]. The program is so light and accessible that you can really run it from any consumer-level operating system, with barely any strain on the CPU. This, in combination with the free and open-source nature of the program, makes it perfect for the software requirements of the future.

It is obvious by now that the paid and closed-source alternatives will have more features, stronger software stability, higher precision, and overall better performance. Nevertheless, pysimCoder still has a chance to become just as good, and still remain free and open-source. This will depend on students and researchers such as myself who will choose to develop further features and abilities to the program. One feature which pysimCoder would highly benefit from is being able to generate and use vector signals. This is something that Simulink already has full support for, therefore having it here will be one step further to a professional-level software, with virtually no financial cost.

In the next chapter, I will be explaining my journey to the extension of pysimCoder for support of vector signals and blocks with vector operations. Before that however, I must explain how the program works internally, and show the code-generation path

from Python to C-code. This explanation will help to better understand the logic behind my implementation of the vector feature, as well as the other features added based on the requirements of this thesis.

2.2 Code Generation Path of pysimCoder

In order to fully understand the implementation of the features which I have added in the pysimCoder project, I must initially explain how the source code is organized and how it functions. When working on an open-source project, the greatest advantage is that you have complete access to the whole source of the application, however this comes with great risk as well. Any small change in the core functionality of the program can lead to unexpected results and errors. Therefore, the developer must always carefully analyze and understand the source code before they start making changes and adding new functions.

2.2.1 Graphical User Interface of pysimCoder

From the front-end perspective, pysimCoder is a graphical tool used for designing block diagram schematics for the purpose of simulation and real-time code generation. Knowing this, it is only natural that I give a small preview of the GUI of the application. As seen in Figure 2.1, the pysimCoder tool is very similar to its larger and more costly counterparts such as Simulink or xCos, as far as the graphical editor is concerned. In fact, the editor itself is based on the PySimEd project [8] and the qtnodes-develop project [9], in combination with a lot of common blocks from PyEdit. [7, chapter 7]

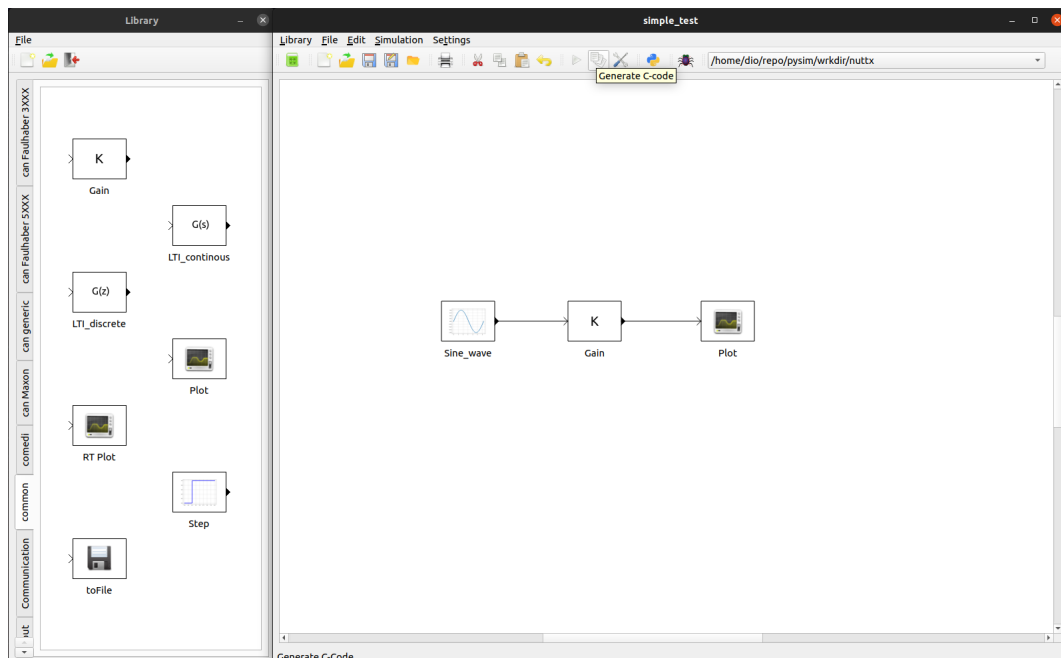

Figure 2.1. Simple preview of PysimCoder’s graphical tool

The application is divided in two windows: the library and the diagram canvas. On the left, we have the library window which contains all the blocks which are supported on pysimCoder. From here the user will be able to drag and drop different types of blocks onto the canvas, depending on their control needs. Then on the right, there

is the canvas window where the user will be able to interconnect all the blocks that were added there from the library. On the top of this window there is a toolbar and a menu bar from which the user is able to perform a handful of operations necessary for their design. The most note-worthy buttons used are: **Generate C-code**, **Simulate**, and **Settings**. These operations are essential to the code-generation and simulation functions of the application.

Regardless of the complexity of the diagram, the work flow (set of operations) will always be the same getting from design to code generation. The blocks are dragged to the canvas from the library, then interconnected based on the user's design. Once the blocks are nicely organized and connected, the user will then have to tune any block parameters that must be changed for their particular system. After verifying the correctness of the diagram, the user will have to choose a target-specific template Makefile which will tell the program which compiler to use for the current project. Finally, the user must save the project, and the **Generate C-code** button will be pressed in order to build a binary executable file. In case of a simple simulation running on the host computer, the **Simulate** button can also be pressed in order to execute the file in the same terminal where the pysimCoder application is running. [7, chapter 7]

Every instruction given above will be related to the next part of this section, where I will explain in simple terms how the source code is reacting to the different operations we are performing in the graphical tool, and what is the final result of the code generation performed by the application.

2.2.2 Source Code of pysimCoder

The core functionality of the pysimCoder project is enabled by three main languages: Python, C, and Makefile. Python is the engine behind the graphical tool, and the back-end processes related to the operation of the tool, and also handles the C-code generation. The generated C code will contain the whole system design with all of its blocks, and their respective parameters and interconnections. Makefile is used for organizing the compilation of the .c files of the blocks, installing all modules necessary for use of pysimCoder, as well as for producing the final executable file which is the end result of the design made in the GUI. Figure 2.2 gives a more simplistic view of the code generation path, from GUI to the executable generation.

Each block from the Library window has three main components which complete its functionality in the code. Firstly, before any code generation takes place, there is the .xblk file which holds all the info of the block which the graphical interface can interpret. These include necessary information such as number of inputs and outputs, assignment of editable parameters along with their default values, name of the block, and also name of the .py file which will be essential to the further processing of the block.

The reference to the .py file specified in the .xblk file is the next step once we want to move towards code generation. This .py file is responsible for calling a python class named RCPblk, whose purpose is to create an object from the current state of the block to be used in the main code connecting it to the other components of the schematic.

Last but not least, the block needs a C-code function that will be used in the main C code generated by Python. This function will contain the actual code necessary for achieving the desired output of the block.

Now I will break down the path of the source code based on the work-flow presented earlier in the GUI. In the initial phase, the design of the schematic is taking place. This includes everything from dragging and dropping blocks onto the editor, making con-

Basics of Code Generation

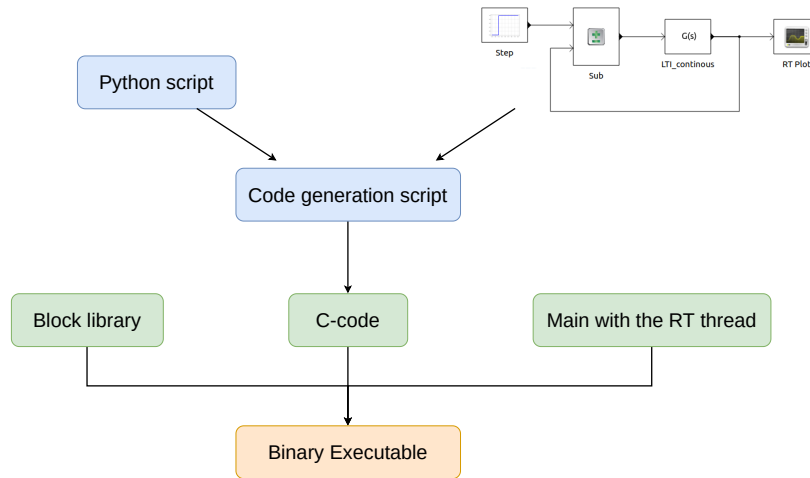

Figure 2.2. Code path from GUI to executable file, inspired by presentation from Prof. Roberto Bucher [10].

nections between them, setting their parameters and choosing the simulation settings. During the design phase, various Python tools from the path `/toolbox/supsisim/src` are being utilized to run the graphical tool, and to ultimately save the state of the current project into a file with `.dgm` extension. This `.dgm` file will contain everything known about the design before code generation takes place, which mainly includes the edited `.xblk` of each block, the connections between the blocks, and the simulation settings.

Once the design of the schematic is completed and saved into a `.dgm` file, the code generation can finally take place. In this phase, the same tools from the path `/toolbox/supsisim/src` will be used. When the **Generate C-code** button is pressed in the toolbar, the `supsisim` toolbox will create a file called `tmp.py` in the working directory, and run it in a separate python3 instance. This script will be responsible for collecting all the blocks and their interconnections, and using them to generate the main C-code. Then it will create a folder in the same path, and it will store there the main C-code that was generated, and also a Makefile. The last step of the `tmp.py` file will be to call the Makefile, which will finally compile the generated C-code into a binary executable. This binary file is the end-product which is obtained from the simulation design, and is the only file necessary for the execution of the simulation on the target-hardware.

The representation seen in the following page shows the directory tree of the `pysimCoder` project. Most of the core work being done by the program is happening at the `toolbox` folder. In the `resources` folder there is all the `.xblk` and `.py` files of each block, as well as all the images used for the blocks' thumbnails. For all code generation purposes of the program, the folder `CodeGen` will be used. Here lies all the C files containing the functions specific to each block (including their dependencies), as well as all the template Makefiles used for the various targets that are supported. These three directories are essential to the `pysimCoder` application, and work closely together during the path from the GUI to the binary executable generation.

Although there are a few parts of the source code I have not explained, there is already enough information given to be able to clearly understand the different implementations and changes that will be made in the forthcoming chapters. Some topics which might be more relevant to a certain feature, will be explained in further detail in its corresponding chapter.

```
-BlockEditor      # Python programs
-Book            # Documentation
-CodeGen         # C resources for blocks and simulations
  -Common
  -linux_mz_apo
  -LinuxRT
  -nuttx
  -Raspberry_PI
  -SAM21
  -src
  -STM32H7
  -templates     # Makefiles for targets
-DriverNRT
-resources
  -blocks
    -blocks      # .xblk files of block
    -Icons
    -rcpBlk      # python files of block
  -icons         # block thumbnails
-Tests
  -ControlDesign # Examples
    -BallOnWheel
    -Disks
    -DisksAndSpring
    -InvertedPendulum
    -PidExample
-toolbox         # Python Control and Simulation Libraries
  -myEnv
  -supsictrl
  -supsisim
-userLib
```

Chapter 3

Vector Support

As mentioned in the previous chapter, it would be of great benefit to the pysimCoder project to have some type of vector support. This is especially true for control engineering tools, since there are many situations where a vector signal might be necessary. In this chapter, the first attempt of experimenting with vector signals in pysimCoder will be described.

3.1 Vectors in Control Systems

As remembered from any elementary mathematics or physics class, a **vector** is a directed line segment. Usually a vector can be visualized on a line, a plane, or a space, otherwise known as the three spatial dimensions. In other words, a vector is a set of numbers, which represent a line with a direction in an N-dimensional space (see Fig. 3.1). Although vectors can have a finite or infinite number of dimensions, they have already played a significant role in mathematics and physics even with only the three spatial dimensions that we are closely familiar with. The uses of vector mathematics reach wide across many fields of science, such as classical mechanics, astrophysics, electronics, and many others.[11] Included here is also control engineering, which uses vectors for many of its mathematical operations.

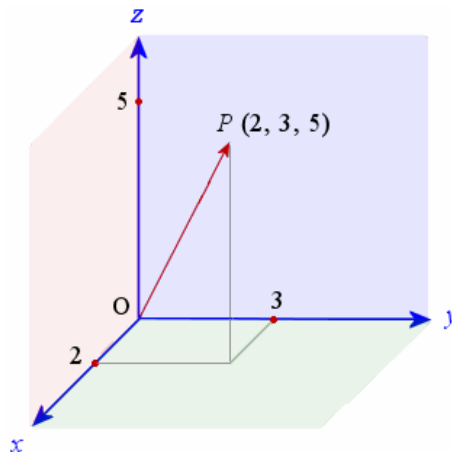

Figure 3.1. Visualization of a vector in a 3-dimensional space (x,y,z axes). The point P represents the direction of the vector, and contains the magnitude as well.

In order to design and analyze control systems, quantitative mathematical models of these systems must be obtained. This condition is true independently of the type of dynamic system in question. The mathematical model of the dynamic system is initially expressed as a set of differential equations, and then usually linearized (if possible) for further use. The Laplace mathematical tool is then able to obtain a solution of these linearized differential equations, and ultimately describe the operation of the system.

Although, today numerical approximations are more generally used for this. [1, chapter 2.1]

Once the mathematical model is simplified with the use of transfer functions, the input-output relationship can be described. This function is especially useful when wanting to represent the system as a block diagram schematic (see Fig. 3.2). The blocks are unidirectional and operate based on the transfer function of the variables to be controlled.[1, chapter 2.6]

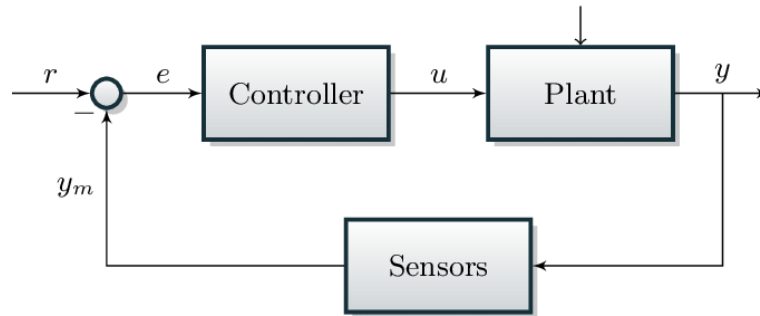

Figure 3.2. Example of usage of block diagram schematics for representation of a closed-loop feedback control system.

Nowadays all the graphical tools for control systems are based on this concept, and many of them use vector signals for operation of their blocks. PysimCoder also uses vectors (and matrices) for many of the mathematical operations necessary for the simulation of a control system, however before my implementation covered in the next sections of this chapter, it did not support the use of vector signals as inputs or outputs of a block. This is a feature that would greatly improve the application, since it can simplify the diagram appearance, and it could better utilize many of the mathematical tools needed for controlling a dynamic system.

Simulink already supports vector signals both in the graphical editor and in the C-code generation tool (SimulinkCoder). The `Constant` block has the ability to produce a single number, but also a vector or matrix. This block can be used to generate a pure vector signal which is constant on its output. There is also a `Mux` block [12] which can combine input signals into a vector, and also its inverse `Demux` [13] which extracts each element from the vector signal and outputs them individually. These blocks can be used in combination with other blocks which may have vectors as an input or output of their operation. Simulink only has a handful of `pure` vector blocks, including `Mux` and `Demux`. Most of the other blocks support single-data signals, as well as vectors on top of that, if the input is given as such.

Many of the same blocks mentioned above that are used in Simulink can be emulated in pysimCoder. Therefore, for the purpose of testing and experimenting with vector signals for the first time in pysimCoder, I have used the same concept of these blocks. I started with a `Constant Vector` block, which could create a pure vector signal, together with a `Print Vector` block to print the signal on the terminal. After that I proceeded with creating the `Mux` and `Demux` blocks, since they will be able to convert vector signals into its individual elements, and back. This can create an interface between the vector blocks and the `normal` blocks. The approach to this will be covered in the next sections of this chapter.

3.2 Basic Implementation of Vectors in pycimCoder

3.2.1 Method of Approach

Although pycimCoder did not have vector support before this implementation, it did have a framework for enabling the dimensions of a block. By creating new pycimCoder blocks which utilize this ability to carry input and output dimensions, I will be able to test the processing of vectors in the C-function level. In order to achieve this I will have to make changes in the source of the code generation tool, as well as adding blocks in a new `Vectors` library. For initial simplicity, the dimensions will be set as a block parameter from the user. The automatic setting of dimensions will be covered later, in the next section of this chapter.

3.2.2 Changes in Python Source and Generated C-code

Before trying to create the new blocks for testing vector signals, first the source of the pycimCoder project must have the ability to enable vectors for these blocks. By making some minor changes to the block representation object, as well as the code generation process, the new blocks will then be able to read their own dimensions in order to properly process the input data.

To better understand where to make these changes, I will refer to the main elements of a pycimCoder block from chapter 2: the `.xblk` file, `.py` file, and `.c` function. In fact, these elements follow a strict hierarchy of representation of a block, as seen in Figure 3.3.

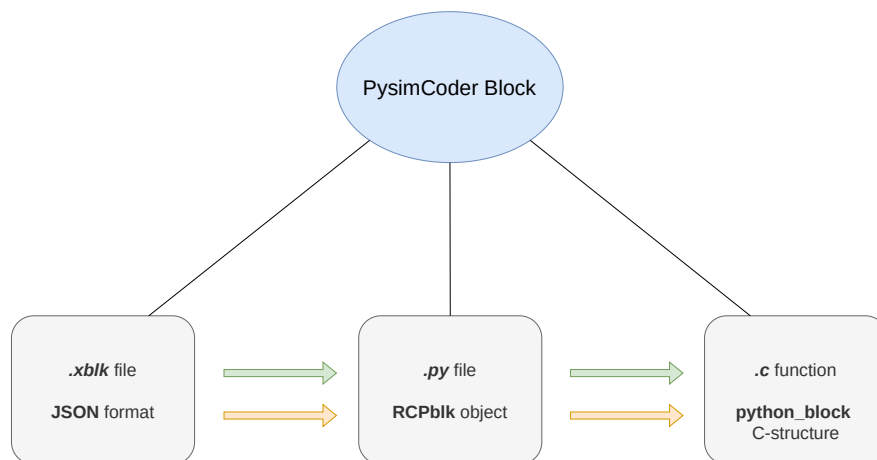

Figure 3.3. The supporting files for a pycimCoder block are shown. The green arrows represent which file contains the specification of the next file or function to be called. The orange arrow shows the switching of block representations. The general direction of both arrows show the hierarchy of the code dependencies of the block.

On the GUI level, the block is initially represented in the same format as the `.xblk` file, otherwise known as the JSON format (although there is no JavaScript involved). The corresponding Python function specific to the block is then called with all the information contained in the JSON, and will ultimately create a Python class called `RCPblk`. This class is the next level of representation, and it will be used while pycimCoder is generating the C-code. When Python is generating the code, it will use each `RCPblk` object to initialize the block on the C-code level. To do this it will pass all of

the block information to a C-structure called `python_block`, which will enable all the written C-functions of the block to utilize its own properties for correct functioning of the code. This C-structure is the last level of representation, and is the only format needed for running of the code on the target. In other words, the other formats only serve to generate this final one. [7]

So all these representations seem to be carrying the block information, and the last two already have some form of support for dimensions of input/output signals. They are seen in the code below, where both of them have the variables already made to carry dimension data.

```
...
typedef struct {
    int nin;           /* Number of inputs */
    int nout;          /* Number of outputs */
    int * dimIn;       /* Port signal dimension */
    int * dimOut;      /* Port signal dimension */
    int *nx;           /* Cont. and Discr states */
    void **u;          /* inputs */
    void **y;          /* outputs */
    double *realPar;  /* Real parameters */
    int *intPar;       /* Int parameters */
    char * str;        /* String */
    void * ptrPar;     /* Generic pointer */
}python_block;
```

For `python_block` there is nothing to change, however in the `RCPBlk` object, all of the dimension information seems to be defaulted to 1 for all inputs and outputs. This is the first change to make, so that when the `RCPBlk` is called from the block's Python code, the dimension will pass from the user's input to the `python_block`. Otherwise it would just default to 1, making vectors impossible to use here.

```
...
    self.name = None
    self.fcn = fcn
    self.pin = array(pin)
    self.pout = array(pout)
    self.dimPin = ones(self.pin.shape)
    self.dimPout = ones(self.pout.shape)
    self.nx = array(nx)
    self.uy = array(uy)
    self.realPar = array(realPar)
    self.realParNames = []
    self.intPar = array(intPar)
    self.intParNames = []
    self.str = str
...

```

After that is settled, the block can then take a dimension as an input parameter from the user, and pass it on to the other representations. This is key to the whole feature, since now I will be able to show how the source code can use this information in order to create actual memory space for the signal.

In `pysimCoder`, the main file which deals with code generation is `RCPgen.py`. In that file is where all the blocks of the simulation are gathered and interconnected, and then generated as C-code. The tool uses the `RCPblk` objects of each block in order to propagate the information to the `python_block` structure. The blocks are interconnected using `nodes`. A `node` in terms of `pysimCoder` is a connection between an output of a block, and the inputs of one or many other blocks. The node will carry the values from one block to another, however the source only generates one value per node. This is another barrier preventing the program from enabling vector support, and it is the next change to be made to prepare the blocks for using vector signals.

In the current version of `RCPgen.py`, it seems that there is only one value given for each node. This setup will not allow any vectors to be generated or used, therefore a short algorithm will be developed to set the correct array space for each node. Generally the nodes must be as large as the inputs and outputs it is connected to, so the array length of each node can be set by the (mutual) dimensions of the connected blocks. Considering this fact, the algorithm will simply go through each block's output, find the dimension of that output, and then append this value to a list which will hold all the nodes' dimensions. Then later on when the nodes are being initialized in C-code, the array length will be set based on the dimension found in the list. The application of this small algorithm will allow the generated C-code to propagate vector values, since it now has memory space to do so.

■ 3.2.3 New Blocks for Vector Testing

After the changes made to the source as explained above, the new vector blocks will finally be able to pass vector signals and use their dimensions for the correct functioning of the C-code. The first vector block to create will be the **Constant** block, as seen in Simulink. This will be able to create a vector output signal based on the input array given from the user. Then to test if the vector signal is actually passing correctly, there is a need for a **Print** block which will be specific to printing vector signals as an array on the main terminal of `pysimCoder`. These two blocks will become the first experiment on vector signals.

The next blocks to be created will be related to mathematical operations on vectors. The **Gain** block takes each element of the input vector and multiplies it by the factor given by the user. In fact the **Gain** block already existed in `pysimCoder`, however it has never been used with vectors as its input. Then two very simple arithmetic operations will be implemented for vectors: summing and subtracting. Describing what they do is somewhat redundant, however it's worth noting that the input vectors of both blocks must be of equal dimension for correct operation. By refining these blocks, I will be able to prove that vectors can be passed, and processed in a mathematical way.

Finally there are two very important blocks which have a special role with vectors in a block diagram schematic. These are the **Multiplexer** and **Demultiplexer** blocks, otherwise known as **Mux** and **Demux**. **Mux** is responsible for generating a vector from many single inputs, while **Demux** breaks down the vector into many single outputs. This functionality will be especially useful in the future, when **normal** blocks want to interact with **vector-able** blocks.

These are all of the vector blocks that have been crafted for the purpose of testing vectors in `pysimCoder`. It is worth mentioning that some blocks are able to know their dimension even without any user input. If the dimensions can be found using some mathematical relation, then it can be passed automatically from the Python file which calls `RCPblk`. Otherwise, the dimension will have to be given explicitly from the input

parameters of the block, therefore it will pass first from the .xblk representation. In the next section I will explain my extended implementation of vectors, where all the dimensions are set automatically by an algorithm, and no user input is needed.

3.2.4 Demonstration of Basic Vector Support (Static Dimension Setting)

To demonstrate the functionality of the first vector feature in pysimCoder, I have prepared some short examples which are using vector blocks. The diagram seen in Figure 3.4 showcases the usage of blocks with mathematical operations (subtraction, sum, gain) on vectors. The vector is summed with itself, and then subtracted by itself, and finally amplified by a gain of 10. The output is shown in the terminal, found in the bottom right corner of the figure. The result should be the same vector, multiplied by 10 (the gain). On the left of the terminal, there is also a small window where the setting of the dimensions can be seen. Further to the left is the Library, where all the vector blocks can be dragged and dropped to the diagram.

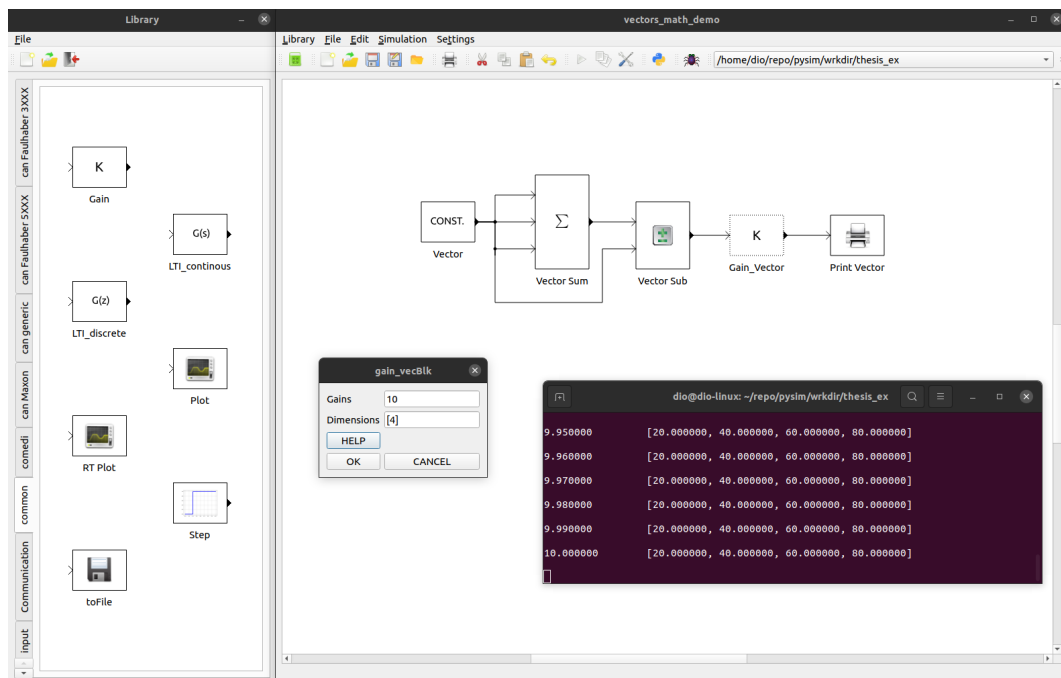

Figure 3.4. Diagram demonstrating usage of mathematical operations on vectors in pysimCoder. Dimensions here are set statically from the user input, as seen in the small window to the left of the terminal output.

In the next figure (Fig. 3.5), there is a very insightful example, which involves the Mux and Demux blocks. Since the two are an inverse to each other, it is possible to connect them to each other, and get the same result from which it started with. Although this seems redundant in a real-life engineering situation, it is in fact a helpful test to see if the two blocks work correctly. As seen in Figure 3.5, the diagram starts with a vector, gets broken down by Demux, and then recollected with Mux. Then the signal is printed on the terminal, and the vector appears to be the same as the input given for the Constant block. This result means that everything is working correctly. The diagram can also be reversed (Mux-Demux), but then the general Constant and Print blocks would be used instead of the new vector versions.

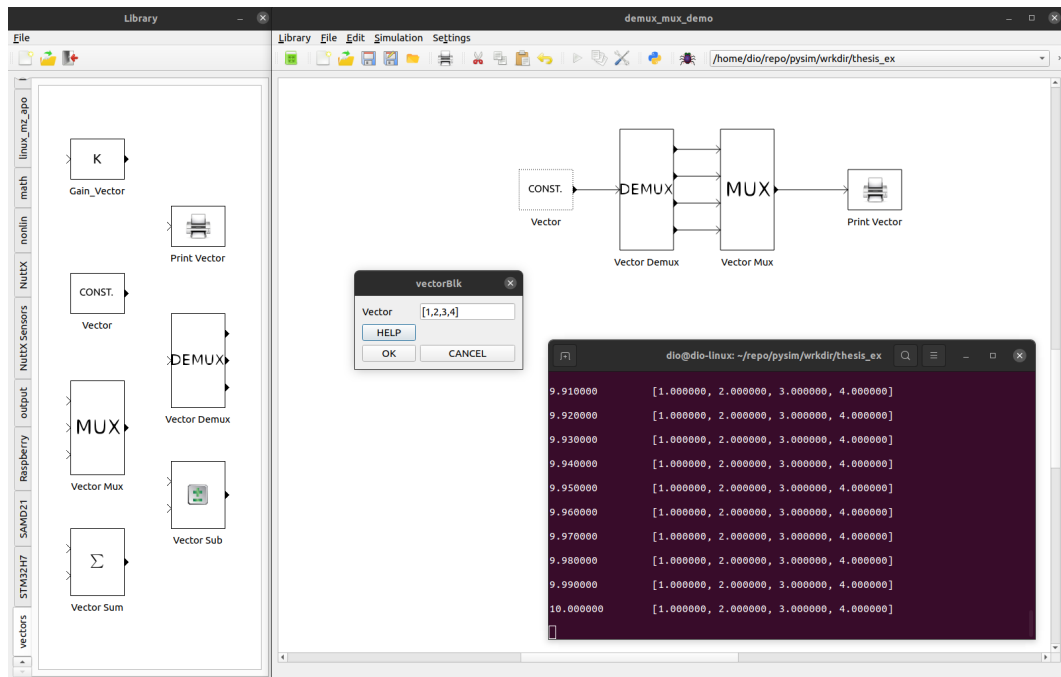

Figure 3.5. Example using Mux and Demux blocks to test each other, as seen from the pysimCoder GUI and terminal. The result of the Print block should be the same as the vector from the Constant block.

3.3 Vectors with Dynamic Dimension-setting Algorithm

3.3.1 Method of Approach

In the initial functionality made for vector support, all the dimensions were either set manually, or set automatically from their internal properties. In this section I will cover the automatic setting of dimensions for all blocks which cannot know their dimensions by their own.

To do this, I will create an algorithm which will find each of these blocks, and set their dimensions based on the output of the preceding block. The detection and setting of dimensions must happen during the code generation process. By implementing this algorithm, the dimensions will not be passed as integer parameters anymore, but will use the appropriate variables for dimensions of input and output seen in the `RCPBlk` object class, and the `python_block C` structure.

It is worth to be noted that there are many approaches to setting dimensions automatically in a block diagram schematic which supports vectors. However, for the purpose of showcasing an experimental version which works with the previously working setup of the vector feature, I have chosen the above methodology. In the future I hope that pysimCoder developers including myself will use this proof as a motivation for a more general and organic solution for this feature.

3.3.2 Development of Algorithm

As seen in the last section, some vector blocks seem to know their dimensions internally, such as `Constant`, `Mux`, and `Demux`. The first two of these also seem to be generating a vector output. For the purpose of the explanation of this dimension setting

algorithm, I will denote these two blocks as **Source blocks**. It is important for this implementation that the **source blocks** always know their dimensions internally, since their dimensions will be passed on down the line.

Other blocks, which previously needed their dimensions to be specified, will then be split into two groups. The **middle blocks** are vector blocks with both input(s) and output(s), while the **destination blocks** are those with only vector input(s). Since the latter only have input signals, then they can simply inherit the dimension from the output of the preceding block. However for the **middle blocks**, there is also the setting of the output signal dimensions, which will need further processing.

To find a way to set the output dimensions of a **middle block**, each input/output relationship must first be investigated. In the best case scenario, the output signal would inherit the dimension from the corresponding input signal, assuming a 1:1 mapping of dimensions. In this case, all the middle vector blocks which were previously created (see section 3.2) have a 1:1 ratio of input/output dimensions, which will make the processing much easier. Nevertheless the chance of having a different ratio when working with vectors in the future is quite high, therefore I have ensured to leave a framework for making blocks which have a more complicated I/O relationship.

To describe the I/O relationship of a block on a mathematical level, I will use the notion of the **dimension ratio**. In other words, this is the ratio between the input dimension and the output dimension. Just earlier it was mentioned that the current **middle** vector blocks all have a 1:1 ratio, which means that the value of the input dimension will be equal to the value of the output dimension. In other cases, the output dimension would have to be multiplied by some factor in order to achieve a natural number. This is the exact reason why I have decided to make a new parameter in the RCPblk class by the name of **dimRatio**. This parameter will hold the information of the I/O dimension ratio, ultimately guiding my new algorithm on how to set its output dimensions.

Now I will proceed to explain the inner workings of the dimension setting algorithm for vector blocks, using the flowchart given in Figure 3.6. The first part of the algorithm will be dealing with the middle blocks, as seen in the left half of the diagram. Once that part is resolved, the algorithm can then continue to process the destination blocks. This has to happen in this order since the destination blocks usually get their dimensions from a middle block.

Initially the middle blocks must be found and accessed (Steps 1 and 2). Then the program must iterate through all the inputs of that block, and proceed to find the **parent** block which contains an output connected to the current input selected (Steps 3,4,5). This input will then inherit its dimension from the corresponding output of the parent block. The output signals of the middle block on the other hand, will be based on the dimension ratio parameter contained in the block (Step 6). If all the inputs have been dealt with, the algorithm will then move to the next phase, involving the destination blocks.

For the destination blocks, the same idea will be applied as for the middle blocks. The main difference here, will be that for destination blocks there are only inputs. This means there is no need for any dimension ratio to help select an output dimension, since there are no outputs. Therefore the inputs of the block will simply inherit their dimension from the parent block's output, and the algorithm will be done (Steps 8-13). Most of the steps are identical as for middle blocks, except for Step 9 and 11.

Although the flowchart seems a bit complex, the idea behind the algorithm is not so hard to understand. The goal is to propagate all the vector dimensions, from a

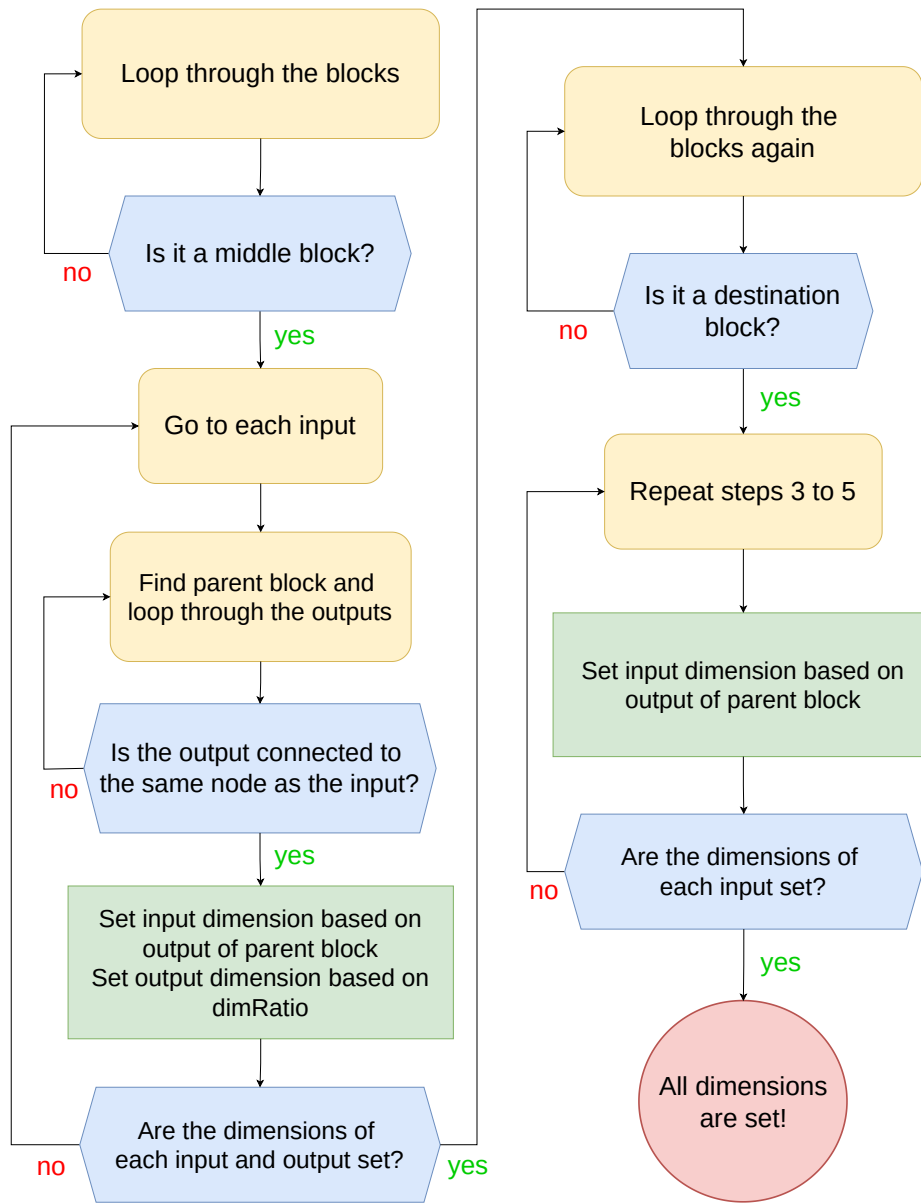

Figure 3.6. Flowchart explaining the path to setting dimensions automatically for vector blocks which previously needed input. Chart is divided in two parts: the left shows the setting of middle block dimensions, while the right is for the destination blocks. The starting point of the flowchart is at the block on the top left.

source block, through the middle blocks, and onto the destination blocks. To do this the algorithm simply goes to each middle block, sets the dimensions based on the block preceding it, and then continues to do the same for all the destination blocks. Also, it is very important that there is a source block preceding all the other ones, and it must have static dimensions which were set internally.

3.3.3 Changes in Source Code

After understanding the core logistics of the dimension setting algorithm, a decision must be made on where to apply the algorithm, and what other changes must be made.

The main changes in the source code will be related to the code generation process, and also to the block definitions of the vector-enabled blocks. Before I explain my choice, it is worth noting that there are many places in the source where the algorithm can be implemented. The only condition is that it is done before the variables of the dimensions are initialized in the code generation process.

Most of the C-code writing that `pysimCoder` does is occurring in `RCPgen.py`, from the `supsisim` toolbox (see subsection 2.2.2). Therefore this file in a way would be the first place to put the algorithm, right before the variables of the dimensions and the nodes are initialized in the C-code. Although this placement works and is more direct in terms of implementation, other methods should be considered for the future. For example it can also be written as a function, and imported externally for this feature, in order to shorten the code in `RCPgen.py`. Another consideration would be to apply the algorithm on the GUI level. This could be handy for seeing all the dimensions before the code is even generated. Nevertheless, the first option has been chosen as a testing ground for the more advanced versions to come.

In order for the algorithm to function, it needs to be able to interact with a parameter used for the dimension ratio, which describes the I/O relationship of the vector block. This parameter will be called `dimRatio`, and it will be placed in the `RCPblk` class. The reason for this placement in the block representation hierarchy, is the fact that the algorithm itself is placed in the `RCPgen.py` file, as mentioned above. The `dimRatio` will be a list with two elements, representing the ratio. The first element is the numerator, and the last is the denominator. In future implementations, the algorithm must be able to use this parameter for all types of ratios that could occur. However, for the current blocks which are contained in the `Vectors` library, there are only 1:1 ratios used (as seen in last subsection). For the `destination blocks`, who don't have any outputs at all, I will use the 0:0 ratio, so that the algorithm can know how to process it.

For the blocks to be able to adapt to these changes in `RCPblk` and `RCPgen`, all of the block file dependencies must be changed. First the input parameter must be removed from the `.xblk` definition, so that the user will not be able to input any dimension manually. Then the `dimRatio` variable must be enabled in the `.py` file of the block, and set to the corresponding ratio involved. Then the C function will also be changed, so that all the functions of the vector blocks will be using the `dimIn` and `dimOut` variables defined in the `python_block` structure. Previously the blocks were using the `intPar` to pass the dimensions in the C-code level, however after the next changes that will be mentioned below, all the blocks will be able to read their dimensions from the newly enabled variables.

I will finish this subsection by mentioning the other changes that were made in `RCPgen.py`. After the algorithm achieves its goal, the variables in the main C file which will hold all the dimension values will then be initialized. The nodes variables will also be initialized with the correct length of array (as seen in section 3.2), however this time it will simply read the dimension from the node output and directly use that value. In the first implementation of vectors, these values were buffered through a Python list. Last but not least, the `python_block` structures given for each block in the diagram will then take the values from the aforementioned dimension variables, and pass them onto the structure's internal dimension variables (`dimIn/dimOut`).

3.3.4 Demonstration of Automated Dimension Setting

Since most of the changes in this section had no effect on the GUI, I will show a very similar demonstration to the first one seen in the basic vector implementation (from previous section). The difference here will be that there is no input dimensions given. If the output on the terminal is correct mathematically, and there are no other errors, then the algorithm has proven itself to work. This proof can be seen in Figure 3.7, however this is a best-case scenario situation. In more complex diagrams there could be some issues.

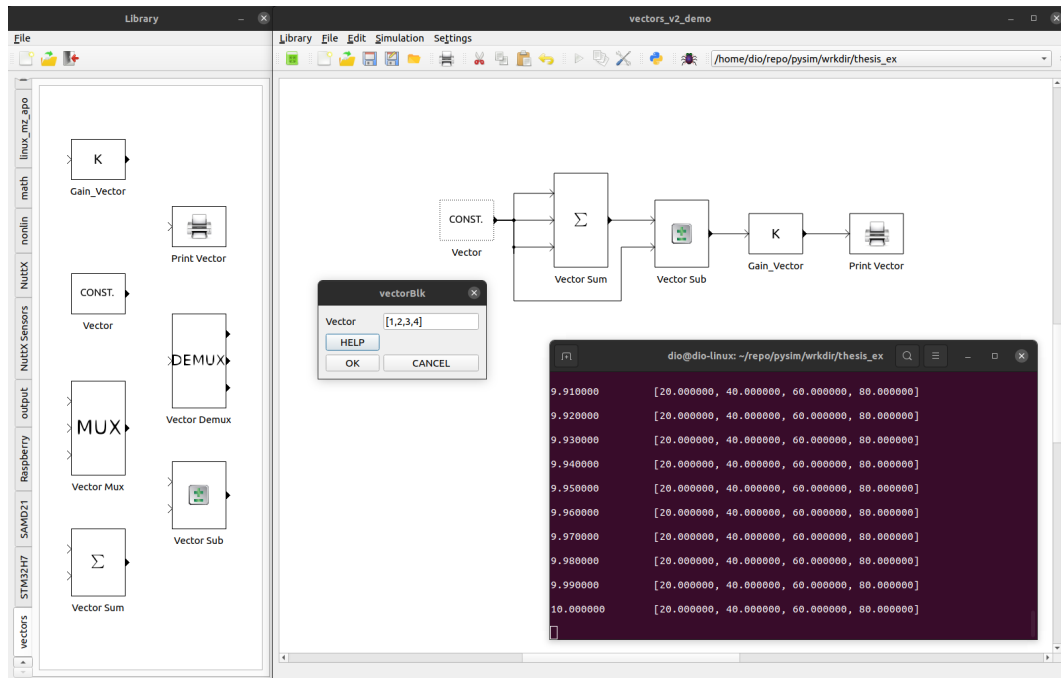

Figure 3.7. View of diagram with mathematical blocks which previously needed dimensions as input parameter, but is now solved automatically from the new algorithm. The result seen on the terminal output is correct, therefore the algorithm has succeeded (since no dimensions were given before).

Chapter 4

Extending Support of GNU/Linux Targets in pysimCoder

As mentioned in chapter 2, pysimCoder can generate code for many different real-time operating systems. One of the main goals of this thesis is to add support for different boards which support GNU/Linux OS. Therefore this chapter will cover all the support added for the Xilinx Zynq based boards, and also the extension of support for the RaspberryPi boards.

4.1 PysimCoder for Xilinx Zynq Based MZ_APO Kit

In the following section I will describe how the first implementation of a Zynq target has been achieved. Most of the code is based on an existing Simulink project, and then adapted for deployment in pysimCoder.

4.1.1 Hardware Introduction

The MZ_APO educational kit is a microcontroller unit based on the Zynq-7000 SoC family, designed by Ing. Petr Porazil at PiKRON sro (Fig. 4.1). The board offers many peripherals and interfaces, which is why it is used as an educational tool for many courses in CVUT such as Computer Architectures, Advanced Computer Architectures, and Real-Time Systems Programming. It uses the ARM architecture, and supports GNU/Linux as its operating system. The details of the board are presented in the following list (full details found at [14]).

- Base Chip: Xilinx Zynq-7000 All Programmable SoC
- Type: Z-7010, part XC7Z010
- CPU: Dual ARM Cortex™ -A9 MPCore™ @ 866 MHz (NEON™ Single/Double Precision Floating Point)
- 2x L1 32 kB data + 32 kB instruction, L2 512 KB
- FPGA: 28K Logic Cells (430K ASIC logic gates, 35 kbit)
- Computing units in FPGAs: 100 GMACs
- FPGA memory: 240 KB
- Memory on MicroZed board: 1GB
- Operating system: GNU/Linux
- GNU LIBC (libc6) 2.28.1 + deb8u7
- Linux kernel 4.19.59-rt22-00005-gedf9096397ae
- Distribution: Debian Jessie

To interact with the device, many common interfaces are supported such as USB, Gigabit Ethernet, UART1 serial port and even a slot for microSD card storage. The peripherals included on the board are various, as it can be seen in the list of the following page (full list at [14]).

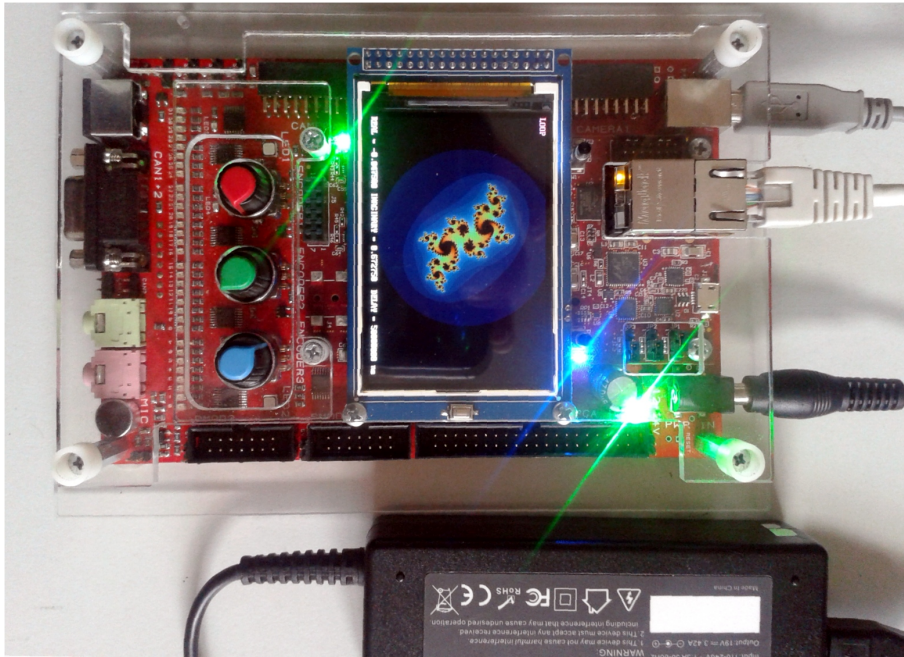

Figure 4.1. The hardware design of the MZ_APO kit is presented. Some main peripherals that can be noticed easily are the LCD screen, three rotary knobs, GPIO pins, LEDs, and the interfaces on the edges of the board. It is commonly used as educational kit for some courses in the Czech Technical University and was designed by Ing. Petr Porazil [14].

- Small 16-bit parallel bus connected LCD display (480× 320, RGB 565)
- 32 LEDs for direct visualization of 32-bit word (SPI connected)
- 2× RGB LED (SPI connected, 8-bit PWM)
- 3× incremental encoder rotary knob (RGB 888, SPI connected)
- 1× 40 pin FPGA IO connector, 36 FPGA 3.3 VDC signals, jumper enables +5 VDC power, signals match Altera DE2 kits
- 2× PMOD connectors extended by optional +5 VDC power, each provides 8 FPGA signals shared with FPGA IO connector
- 2× parallel camera interface, one 10-bit and one 8-bit
- audio output by simple PWM modulator, on-board speaker and JACK available
- audio input to Xilinx integrated ADC, on-board microphone and JACK

Many of the peripherals above can be implemented in pysimCoder as blocks, however for the scope of this thesis I will be working with the rotary knob **incremental encoders**, as well as the **PMOD connectors**. These two peripherals are already implemented as Simulink blocks, as it will be presented in the next subsection.

The three incremental encoders are physical rotary knobs which can change values in an 8-bit field (from 0 to 255). These can be useful in pysimCoder for adding variability to a signal using some human input. The implementation will be covered in the next parts of this section. [14]

The PMOD connectors are also of high interest for this thesis, as they will be the interface between the board and some DC motor. There are two of these slots, and they will in fact be connected to some DC motor driver, which will handle the actual output of the voltage on the motor. [14]

■ 4.1.2 Existing Simulink Project

Since `pysimCoder` and Simulink are very similar in the aspect of code generation, it is sometimes possible to translate blocks from one program to another. Thankfully, there is already a Simulink project which can generate real-time C code for controlling the peripherals of the MZ_APO educational kit. The source of these blocks can be found in a public online repository [15], and has been developed while using the `ert_linux` target for Simulink.

`Ert_linux` is a code generation target for Simulink which is specifically tailored for `preempt_rt` Linux distributions. The project offers an alternative to the existing Linux code generation targets offered by MathWorks which seem to have some shortcomings. The main advantage `ert_linux` has over the default targets is that it uses `clock_nanosleep` instead of POSIX timers, which results in better real-time performance in the `preempt_rt` Linux versions [16]. The source found in Github [17] consists mainly of the main program template and the Makefile template, both of which are analogous to the templates of `pysimCoder` used for generating real-time code meant to run in a Linux OS environment.

The `zynq-rt-control` project (also found in Github [15]) contains Simulink blocks and diagrams which are used for controlling the peripherals of the MZ_APO Zynq-based board. In order to use these resources to generate code however, it must use the `ert_linux` target for Simulink, since it was designed using this template. Before translating these blocks into the `pysimCoder` environment, it is important that the Simulink diagrams are tested and verified on actual hardware. In this case there are only two peripheral blocks used: knob input (incremental encoders), and DC motor (PMOD connectors). The rotary knobs are already embedded on the board, so that can be tested out of the box. For the testing of the other block, a DC motor and driver which connects to a PMOD connector is required. The proper connection of such a device will be presented at the end of this section.

From the `ert_linux` repository, it will be helpful to extract which cross-compiler must be used for generating code on the Zynq board. Then most of the C code needed for the peripheral control will be contained in the `zynq-rt-control` repository. By combining elements of these two projects, a similar implementation can be applied in the `pysimCoder` application. Therefore the work done on these projects will be the base of my work on adding support for the MZ_APO educational kit.

■ 4.1.3 Integration with `pysimCoder`

In this subsection I will be explaining my approach to translating and integrating the Simulink projects mentioned above, into the `pysimCoder` environment. This will be the first implementation of a Zynq-based board, therefore a new template Makefile must be created, as well as new blocks with all their supporting files.

To construct the template Makefile for a Linux target such as the MZ_APO kit, the same cross-compiler specified in the `ert_linux` project should be used. The rest of the structure of the Makefile will then be taken from the existing real-time Linux targets supported in `pysimCoder` (found in source path `/CodeGen/templates/rt.tmf`). The compiler specification will be switch from `gcc` to `arm-linux-gnueabi-gcc`, which ensures that the host will be able to compile binary code compatible with the Zynq based board.

Next the existing Simulink blocks must be translated into `pysimCoder` blocks. Fortunately, the C code functions which the two use are very similar. Although in Simulink there are many more functions, some of them are not related to the target manipulation,

4.1.4 Demonstration of Results

To prove the functionality of both of the new blocks in one diagram, I have prepared a demonstration in pysimCoder. There will be two motors used, and one of them will be following the position of the other. The three rotary knobs embedded on the board will then be used to tune the values of the PID controller. All the hardware necessary for this demonstration is listed below, while the source code for running the example can be found in an online repository [18].

- Host computer with pysimCoder installed
- 1x MZ_APO educational kit
- 2x DC motor for MZ_APO educational kit
- 1x Ethernet Cable
- 1x DC power supply (12-24)V
- 2x Coaxial male-male cables

First the MZ_APO kit must be connected to two DC motors using the PMOD slots. Then the three devices must be connected to the power supply in a daisy-chain pattern, using the two coaxial cables. Last but not least, the Zynq board must be connected to the same network as the host computer using an Ethernet cable. This will enable communication between the board and the host. The hardware setup can be seen in Figure 4.2.

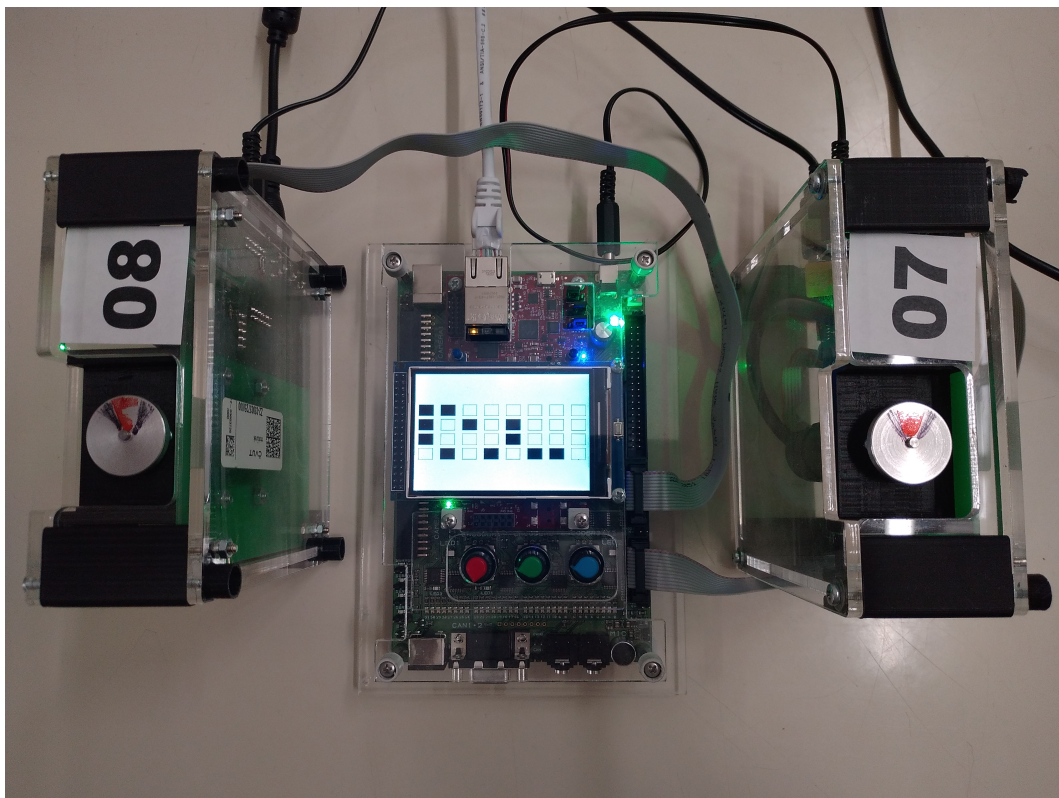

Figure 4.2. The two motors are connected to the Zynq board, while the knobs are used to tune the PID controller. Both the motors are in the same position, which is the desired output of this diagram.

With the hardware all set up, the diagram of the example can be opened (see Fig 4.3), and all the parameters can be edited as needed. There are three encoder

blocks, and each one of them controls a different part of the PID controller. Although there exists a PID block in pycoder, the parameters can not be variably controlled by another block. Therefore each individual element of a PID controller has been deconstructed, and enabled for control by the knobs. One DC motor block is fed by a zero-voltage value, and it will serve the purpose of setting the IRC reference position (steering wheel). Another DC motor is connected on the input by the PID controller, and on the output as a negative feedback loop (to be subtracted with reference), which produces a control error signal to be fed back to the PID. Naturally it will be seen as the controlled motor. The TCP block at the right most part of the diagram will then be used to propagate these signals to a TCP listener with graphing capabilities.

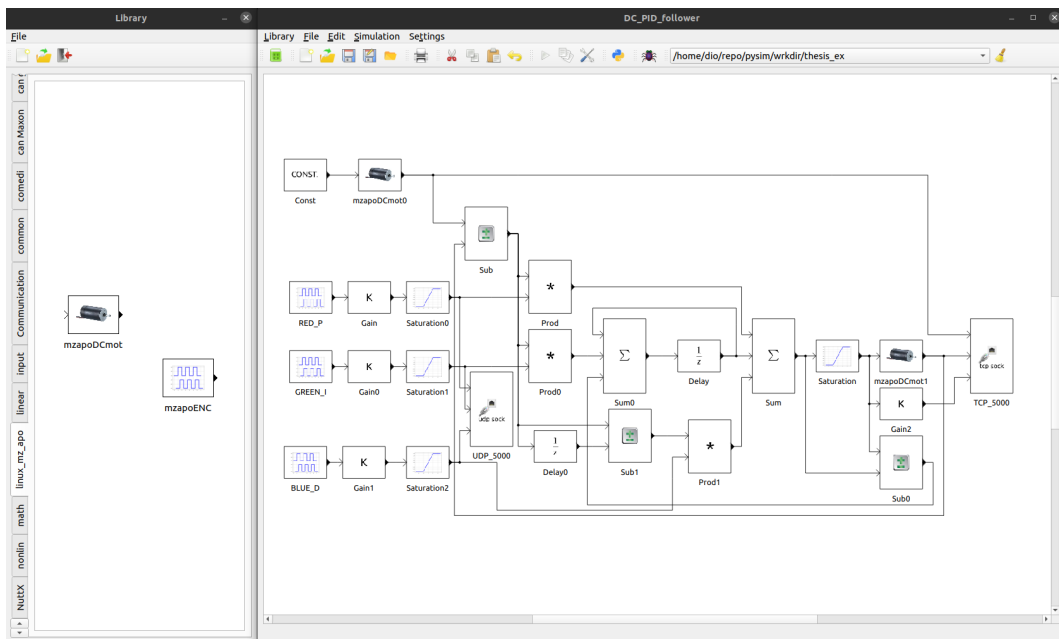

Figure 4.3. Three knob blocks control the PID values. One DC motor is fed by some constant value, while the other is connected in a negative feedback loop and controlled by a PID controller. The signals are sent through TCP for recording and graphing.

Finally the code can be generated, while the uploading and execution of the binary on the Zynq board will be handled by the shell script file found in the online repository [18]. Inside this file are two commands similar to the ones below, where the `HOST` and `TARGET` environment variables are referenced. These variables can be set through a terminal, or can be edited in the shell script itself. The commands can also be run by the user in the same form as below, only replacing the IP addresses based on their network.

```
scp DC_PID_follower root@192.168.0.20:/tmp
ssh -t root@192.168.0.20 HOST=192.168.0.100 /tmp/DC_PID_follower
```

After `RTScope.py` is started and configured for number of receiving channels, as well as for desired communication protocol (TCP), the generated application can be started. Using the TCP block in pycoder, some select signals will be transmitted to the host computer, and visualized in a graph. The terminal commands for achieving this are below.

```
./RTScope.py
./DC_PID_follower-run.sh
```

4.2 pysimCoder for Raspberry Pi Target

Raspberry Pi support on pysimCoder in fact already exists, however the translation of an existing Simulink project [19] can be used as a stepping stone for demonstrating the usage of pysimCoder on an ESP32C3 board with NuttX RTOS (covered in the next chapter). Due to this fact, the steps for implementing extended support for a RaspberryPi target will be evidently shorter than the one for the MZ_APO kit.

4.2.1 Hardware Introduction

In the example from the `rpi-rt-control` project (available on Github [19]), a RaspberryPi board can control a 3-phase permanent magnet synchronous motor (PMSM) using code generated by SimulinkCoder. The hardware necessary to test this example will be covered in the following text.

RaspberryPi is essentially a small computer or a microcontroller, which can interact with hardware peripherals for various types of projects. It's easy operation allows people of all ages and backgrounds to use it, making it a great asset for educational purposes [20]. The main technical specifications of the device used in this project can be found in the list below, taken from the official RaspberryPi website [21], while the hardware itself can be seen in Figure 4.4.

- A 900MHz quad-core ARM Cortex-A7 CPU
- 1GB RAM
- 100 Base Ethernet
- 4 USB ports
- 40 GPIO pins
- Full HDMI port
- Combined 3.5mm audio jack and composite video
- Camera interface (CSI)
- Display interface (DSI)
- Micro SD card slot
- VideoCore IV 3D graphics core

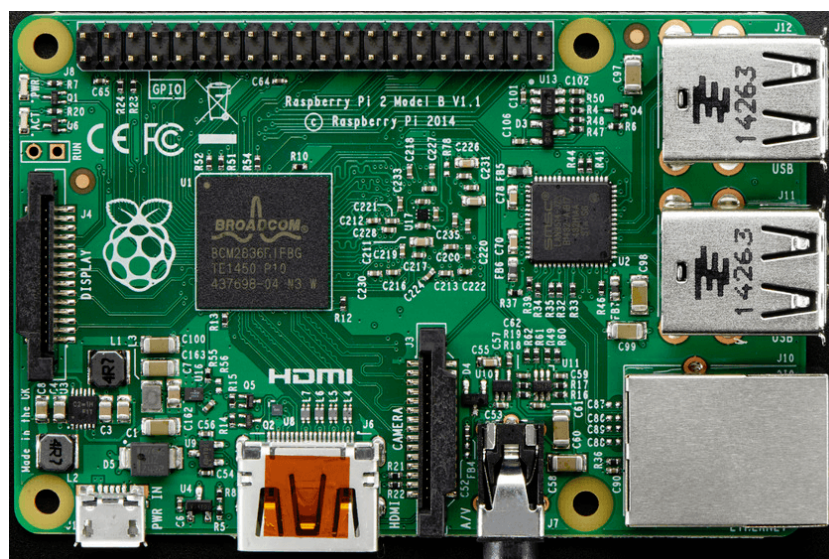

Figure 4.4. The physical appearance of the specific RaspberryPi used in the PMSM control demonstration for Simulink/pysimCoder. Produced in 2014, it is a Model 2B (v1.1).

Unfortunately a 3-phase PMSM cannot simply be plugged into this board and used out of the box. For this reason, additional hardware will be required, such as a 3-phase motor driver, and a FPGA expansion unit. Luckily, these devices have already been produced by Petr Porazil from PiKRON for a different project for the Czech Technical University, while the FPGA design was provided by a Bachelor's thesis work done by Martin Prudek (for the same university) [22]. Therefore this hardware can in fact simply be connected and used, especially for the purpose of motor control (see Fig 4.5).

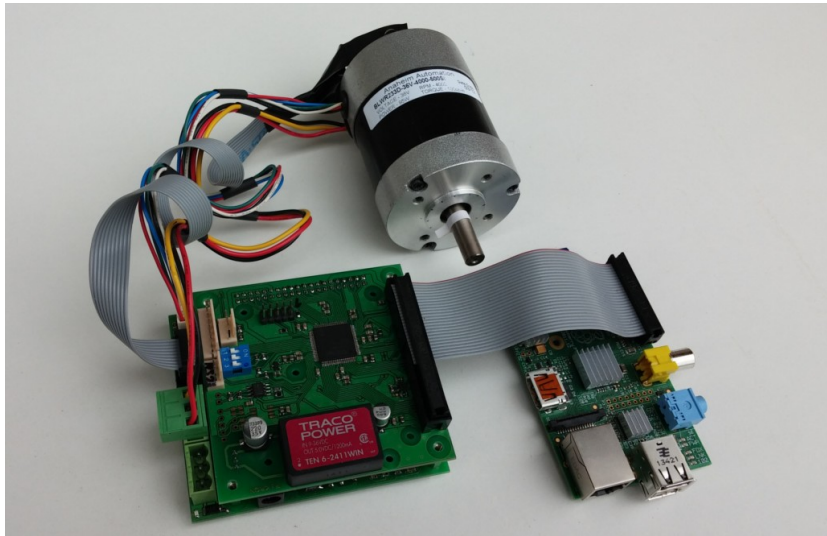

Figure 4.5. Hardware setup for motion control of 3-phase motor (PMSM) using RaspberryPi board and Simulink. The motor is connected to the motor driver, the FPGA board is fitted on top of the driver, and the RaspberryPi is connected to the expansion board with a HAT cable module. Note that the board in this picture is one model older than the one used in my implementation.

The motor driver board's main task is to connect all of the I/O cables of the motor to the expansion unit. This includes connections for the IRC, the Hall effect sensors, and the 3-phase windings of the motor. It will also serve as the power source of the motor and the boards attached to it, once it is connected to a DC power supply. Other components include an ADC, half-bridges, and current measurement signals.

Even with the current amount of hardware, the microcontroller unit still cannot be attached and used. This is due to the fact that the specific RaspberryPi board used for this example does not have any IRC input, and only contains one PWM output, making it unfit for motion control situations [16]. Fortunately, the FPGA expansion unit was specifically designed to act as a middle-man between the motor driver, and the pins of the RaspberryPi board.

Field programmable gate arrays (FPGAs) are semi-conductor devices which can (re)program configurable logic blocks in order to achieve a certain logical system design. The specific FPGA design for this example can be used in a few different modes. For example, one mode is used for motion control of a DC motor, where it converts the IRC signals, and switches PWM to be usable in both voltage directions. Then there is the mode relevant to this project, which will enable the motion control of a 3-phase motor. The fully described FPGA design can be found in Martin Prudek's Bachelor thesis [22].

To communicate with the FPGA expansion unit, the RaspberryPi board will use its SPI pins. Then the source of the FPGA will be able to send and receive signals from

the MCU to the motor driver successfully. In addition to this, the expansion unit also holds a DC voltage converter which will be able to give a stable 5 Volts that the SoC needs for operation, while the 3.3V pins of the SoC will route back to the expansion kit for operation of the FPGA circuitry. More details about this hardware setup and the PMSM Simulink example can be found online [23].

■ 4.2.2 Existing Simulink Project and Adaptation to *pysimCoder*

As mentioned previously, I will use an existing project made for Simulink, in order to make a new block for PMSM control in *pysimCoder*. The files of interest for the following implementation can be found in the `rpi-rt-control` online repository [19]. Only the files related to the PMSM motion control will be used, which include the block C file and its dependencies, as well as the Simulink diagram used for the control system.

For the conversion of the Simulink block to a *pysimCoder* block, the same approach from the previous section will be utilized. The blocks of code will be extracted from each Simulink function and copied onto the corresponding *pysimCoder* function. Then all the parameters must be adapted to the `python_block` structure, and the supporting header files specified on the top of the C file. All the dependencies mentioned must also be copied onto the `devices` and `include` folders of the RaspberryPi target, in order to enable the proper compilation of the block's C code.

In this particular Simulink block, there are also vector inputs and outputs. To avoid possible issues, I have simply split all these signals into individual inputs and outputs, rather than using the experimental vector feature in *pysimCoder*. This decision will ensure that the cause of some error message will more likely be related to the new code which was added.

A RaspberryPi target for cross-compilation is already supported in *pysimCoder*, and in fact there is already a whole library of blocks to generate code for these boards. Therefore, all the block related files (`.xblk`, `.py`, `.c`) which were adapted for the new PMSM block can simply be added to their corresponding folders. The C file in particular should also be compiled in its folder using the `make` command in a terminal, so that the code generation tool will be able to use the new block. In other words, there is no need to create any folders, or to construct any Makefile templates.

There is also a Simulink diagram which can be used to test the functionality of the block on real hardware. The same principles of this diagram will be emulated in the *pysimCoder* environment, as it has all the blocks necessary to do so. The implementation will be covered in the following subsection.

■ 4.2.3 Demonstration of Results

To test whether the adaptation of the block has succeeded, a real-life example should be tested. Therefore all the hardware must initially be set up (Fig. 4.5), and a diagram in *pysimCoder* should be constructed to demonstrate the motion control of a 3-phase motor (see Fig. 4.6).

Fortunately, most of the blocks used in the Simulink diagram, can also be found in the *pysimCoder* library. Nevertheless the diagram will be simplified and cut down so that only the necessary functions will be used. Some parts of the diagram in Simulink have a lot to do with graphing, however for the purpose of this demonstration only the signals of higher interest will be visualized.

The new RaspberryPi block has 6 inputs, and 7 outputs. The first three inputs will be the PWM signals being fed to the motor, while the last three inputs are `enable`

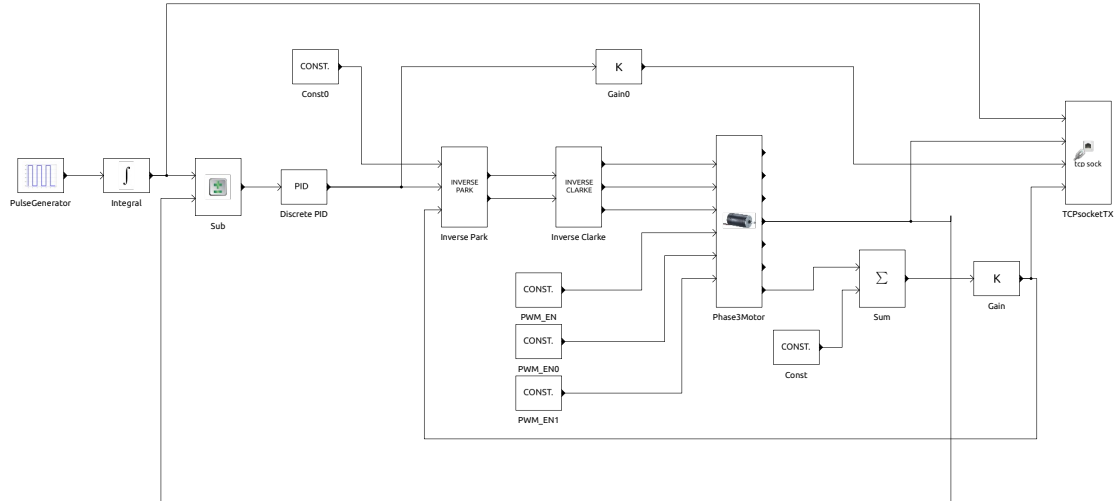

Figure 4.6. PysimCoder diagram for control of 3-phase PMSM using RaspberryPi target. Design has similarities to the original Simulink diagram, however it has been reduced only to the necessary control signals and blocks.

signals (which allow usage of a certain PWM signal). Then on the first three outputs are measurements of the current output, one for each phase. The next three are outputs related to the IRC, and the last output will be for the HAL sensor measurements.

The first three inputs of the PMSM block will be supplied by an *Inverse Clarke* math operation block, which is previously fed by an *Inverse Park* block. Into the latter, there will be one constant signal (zero for this case), one PID controlled signal, as well as a feedback signal from the processed HAL measurement. The integrated pulse wave signal (equivalent to a triangle signal) seen on the far left, will be used as the reference for this control system, and it will be subtracted with the IRC output before being fed to the PID controller as a control error signal. At the very right there is also a TCP block, which will transfer select signal data through a TCP/IP connection with the host computer. This connection can then be utilized by the *RTScope.py* program in order to graph all the incoming data points (same as done in last section).

With the diagram all set up, the C code can finally be generated. The binary will simply be transferred and executed on the RaspberryPi, considering all the hardware is connected properly. Although it is possible to interact with the board using the serial terminal, it is recommended to use an SSH connection instead. Therefore the RaspberryPi and the host must be connected to the same network (same as for the *MZ_APO* demonstration). On the host, the *RTScope.py* program must be started to enable the receiving and visualization of the incoming data. A preview of this example can be seen in Fig 4.7.

The graph in Figure 4.7 is the result of the control system applied in the RaspberryPi board for motion control of a PMSM. In red is the reference signal being fed to

the system, while in green is the actual motor position (decoded from the FPGA). It is clearly seen that the two signals are in sync when there is no disturbance to the system. However, as seen from the control action signal in blue, once a disturbance is applied the controller will try its best to compensate. The IRC output seems to be slightly shifted to the right, however it still follows the same rate of change as given from the input signal. Once the disturbance is removed, the IRC immediately synchronizes with the input again. This is in fact the desired system response for this setup, therefore it has been proved that the new PMSM block has been successfully integrated into pysimCoder.

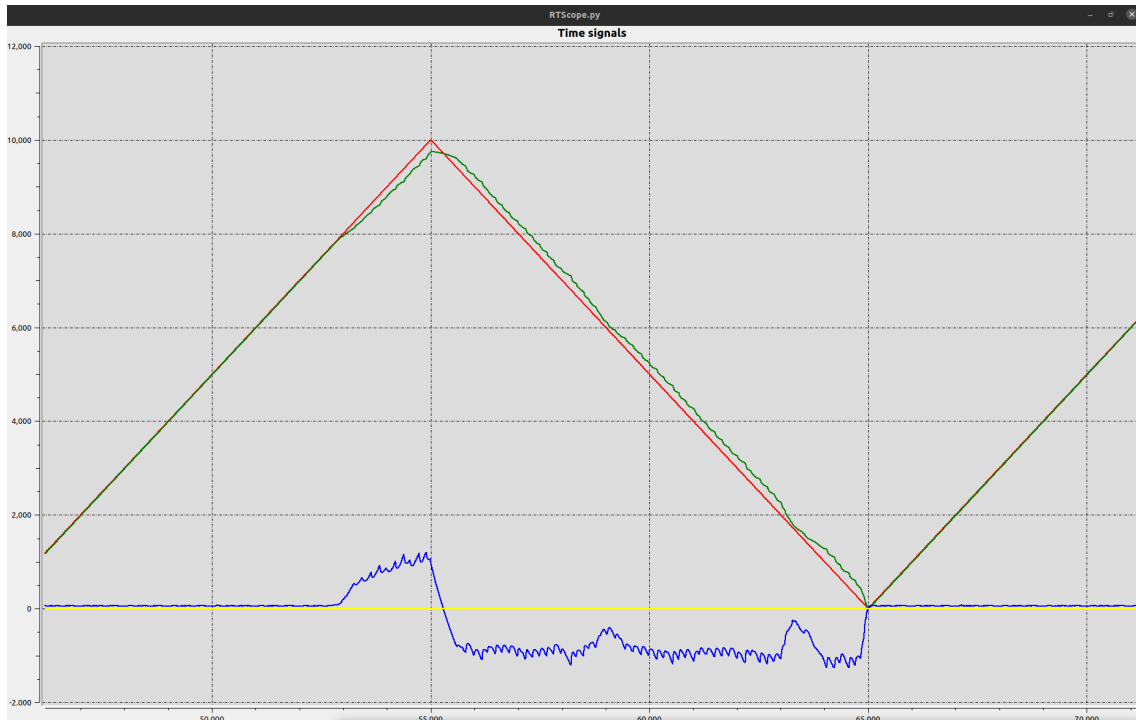

Figure 4.7. Graph showing select signals from the PMSM motion control example using the RaspberryPi. The vertical axis will be dimensionless, since the signals graphed do not have the same units or range of values for that matter. The horizontal axis represents time in seconds. This graph is a screenshot taken from the RTScopy.py program, and is only for testing purposes.

Chapter 5

Testing and Extending NuttX RTOS Support in pycimCoder

5.1 NuttX RTOS

5.1.1 Introduction

NuttX is a real-time embedded operating system (RTOS) designed for high scalability, small footprint, and standards compliance. It supports architectures from 8-bit to 64-bit, and is compliant with the POSIX and ANSI standards. Although NuttX tends to be very small, it is still very rich with features. This is possible since the final build of NuttX will only import the configured features, leaving all the unused ones out. [24]

The main supported CPU architectures can be seen below, while the full list and details can be found online in the NuttX documentation [25]. RISC-V will be of high interest for the scope of this thesis, therefore its support on NuttX will be crucial to the rest of this chapter.

- ARM
- Intel
- RISC-V
- Atmel AVR
- Freescale
- Microchip
- Xtensa LX6

As can be noticed from the NuttX documentation online, there is a very long list of supported features. This raises the question of how it can be so small, and still have all these features available. Although there are a lot of files in the NuttX source code, the code contained inside is usually very short and compact (sometimes just a few lines). This in combination with linking from `static libraries` can ensure that NuttX can simply exclude the code which is not necessary for the current build, which ultimately makes the OS much smaller. [24]

Another trick to keep NuttX tiny is by using `configuration files`. In this file all the features can be enabled or disabled depending on the project requirements and limitations. Additionally, the GNU toolchain supports `weak symbols`, which help to keep the size of NuttX down. [24]

It is worth mentioning that NuttX OS is a completely free software, shared online with a non-restrictive Apache license. The source code can be found on a Github repository [26], and the true open-source nature of NuttX even allows for anyone to add their own support on the project, either locally on their computer, or uploaded to the online repository.

■ 5.1.2 Existing Support in pysimCoder

In pysimCoder, there is already existing support for NuttX targets. This means that any microcontroller running NuttX, can also execute binary code generated from the pysimCoder application. That is an amazing feature, since for most use cases pysimCoder has hardware blocks which are specific to a certain microcontroller or architecture. In the NuttX blocks, the code will be identical no matter what CPU brand is used.

NuttX has many features involving the control of hardware peripherals, therefore these functions can be used as pysimCoder blocks. In fact there is already some blocks made for NuttX, such as an ADC, DAC, Digital Input/Output, Encoder, PWM, and a DHTXX sensor. Some general pysimCoder blocks can also be used, including the TCP, UDP, UART, and CAN communication protocols. [27]

Although the NuttX blocks will generally work for any NuttX supported microcontroller, there is still some specification involved in the `configuration` file. As mentioned earlier, the RTOS uses configuration files for setting up the system so that it doesn't include any redundant code in the final compilation. The configuration of NuttX should be set up not only to specify the hardware being used, but also to set certain features that will make the compilation compatible with pysimCoder [27].

NuttX will use this configuration which was set up by the user, in order to compile only the necessary files. This compilation can then be exported to the pysimCoder source, and then utilized by the NuttX blocks appropriately. So the various hardware support of NuttX can in fact be propagated to pysimCoder, however this must be configured by the user externally. The full configuration and steps can be found in the online documentation for pysimCoder with NuttX [27].

■ 5.2 ESP32C3 Board with NuttX RTOS

It would be of good interest to the pysimCoder project to somehow test a microcontroller which uses the RISC-V architecture. NuttX already has support for a board with this architecture, therefore the hardware can be easily implemented in pysimCoder. The following section will describe the simple testing and configuration of the selected hardware, both in NuttX and pysimCoder.

■ 5.2.1 Hardware Introduction

One of the RISC-V boards which is supported in NuttX is the ESP32C3 produced by the Espressif company. Fortunately, the Espressif representation in Brno (Czech Republic) was kind enough to provide my supervisor with some of these boards for the purpose of student research.

The specific hardware provided is the `ESP32-C3-DevKitM-1` (see Fig. 5.1), which is an entry-level development board popular for its small size and vast IoT capabilities. It is based on the `ESP32-C3-MINI-1`, a module which contains a whole system, including the CPU, the memory, the WiFi and Bluetooth antenna, and many more supported peripherals. The specifications of the hardware can be seen below, while the full details can be found online. [28] [29]

- ESP32-C3FH4 or ESP32-C3FN4 embedded, 32-bit RISC-V single-core processor, up to 160 MHz
- 384 KB ROM
- 400 KB SRAM (16 KB for cache)

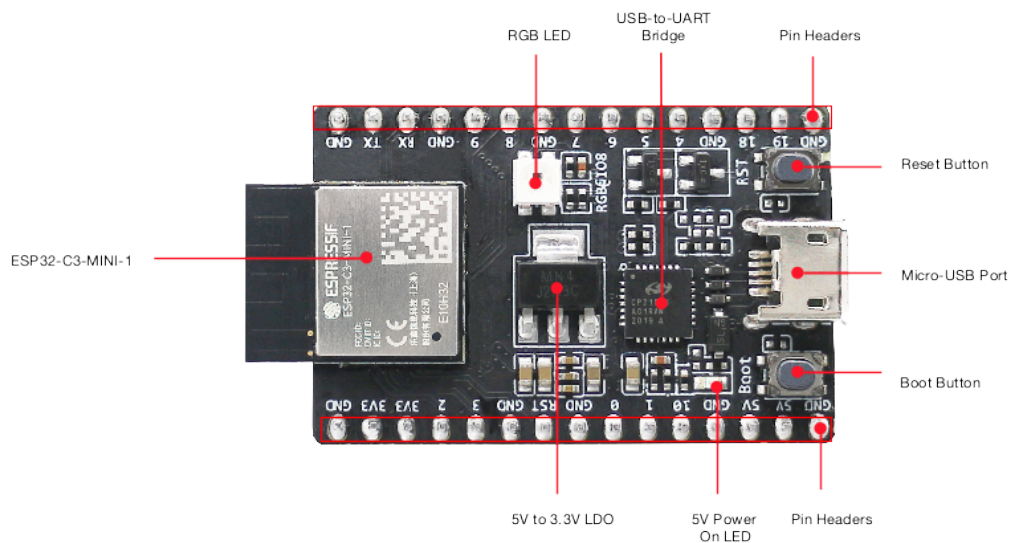

Figure 5.1. The different components of the ESP32C3-DevKitM-1 board are presented with labels. On the left is the main chip, while on the right is the micro-USB connection. The pin headers can be found on the top and bottom. Other components include RGB LED, Reset and Boot buttons, 5V to 3.3V LDO and more.

- 8 KB SRAM in RTC
- 4 MB embedded flash
- WiFi - IEEE 802.11 b/g/n-compliant, 2412 2484 MHz
- Bluetooth® - Bluetooth LE: Bluetooth 5, Bluetooth mesh, up to 2 Mbps
- 40 MHz crystal oscillator
- GPIO, SPI, UART, I2C, I2S
- Remote control peripheral
- LED PWM controller
- General DMA controller
- TWAI® controller (compatible with ISO 11898-1)
- USB Serial/JTAG controller
- temperature sensor
- SAR ADC

Considering the very small size of the board, its extensive support of various peripherals is impressive. This makes the board very useful in different types of applications, such as for home automation, industrial automation, smart agriculture, consumer electronics, health care etc. I hope that by implementing this board in pysimCoder, it will become apparent that my project will fall in the category of educational automation. This is one field that was not yet mentioned as an example in the datasheet of the device. [29]

■ 5.2.2 Installing NuttX RTOS on ESP32C3

Before trying the ESP32C3 on pysimCoder, it will be necessary to load and test the NuttX RTOS on the board. To do this, the project must first be cloned from the existing Git repository [26] using the following command:

```
git clone https://github.com/sonydevworld/spresense-nuttx.git nuttx
git clone https://github.com/sonydevworld/spresense-nuttx-apps.git apps
```

Considering there is already support for the ESP32C3 on NuttX, some examples can be directly loaded. For each board on NuttX there is a corresponding directory in the source, which is full of ready-made configuration files for that specific hardware. These setup files can be loaded using a shell script, and can even be modified after based on the desired features.

There are a few different ways to approach the configuration of NuttX. The best way to initialize the setup is to run a ready made script who's purpose is to load a pre-made configuration file (`defconfig`). Once that is loaded, there are two graphical applications which can help to edit the initially loaded configuration, in order to add or remove features based on the project needs. The first graphical tool can be called by `make menuconfig` command, which will bring up an interactive menu in the terminal. Here the features are presented in a more user-friendly way. There is also another tool called by `make qconfig` command, however this will actually load every single feature possible in the NuttX compilation, therefore it is mostly used for searching through the variables and setting them manually. Once finished editing, the configuration can actually be saved into a `defconfig` file, which can then be loaded by the aforementioned shell script as an initial setup.

Another possibility can be to find all the configuration variables which are needed, and their properties, and write them into a `defconfig` file manually. Then theoretically this file can in fact be loaded by the shell script, although it is not recommended by NuttX to do so. A more clean way will always be the method discussed in the last paragraph. Therefore, that method will be used to initially test NuttX on the RISC-V board, as seen in the following steps given.

```
./tools/configure.sh esp32c3-devkit:nsh
make menuconfig
make
```

For the purpose of initial simplicity, the example which has been chosen to be pre-loaded is a NuttX application called `Nuttshell`. This is a terminal console for NuttX devices, which can be accessed usually over a serial connection (UART or USB). If this tiny shell console can be opened in the host computer, then it proves that the NuttX RTOS has been successfully loaded to the board. Before this is verified, the graphical tools can be used to add more features to the compilation (as seen in second command above). If the desired configuration is ready and saved, the `make` command can be executed in order to perform the compilation of the whole NuttX RTOS in one binary file. In the case that the configuration needs to be saved for future use, it can be saved into a `defconfig` file using the following command.

```
make savedefconfig
```

It seems that there were no issues while loading the RTOS in the ESP32C3 board. The command line terminal did in fact succeed to connect to a serial connection on the host computer, and even some other examples were added, although not tested. Now that the installation of NuttX has been verified and described, the actual hardware peripherals will be tested in `pysimCoder`. The integration to `pysimCoder` will be covered in the remaining parts of this chapter.

5.2.3 Enabling and Testing pysimCoder on ESP32C3

As mentioned beforehand, there is already a full documentation on how to integrate NuttX with pysimCoder [27]. Using that guide, the existing configuration set up for ESP32C3 (in previous subsection), can be modified so that it can also deploy pysimCoder code. In other words the two configurations will somehow be merged, so that they are compatible with each other.

The current ESP32C3 configuration should be opened, preferably with `qconfig` tool, and each `CONFIG` variable seen in the online documentation should be set manually. Once the changes are saved, the source should be compiled, and ultimately exported to pysimCoder (see commands below) in the `/CodeGen/nuttX` directory. When the `CodeGen/nuttX/devices` folder is recompiled, pysimCoder will be ready to generate code for the ESP32C3. Unfortunately there was an issue encountered regarding a missing header object file specification in the exported build. This was solved by specifying the header file manually, although this is not a general solution. [27]

```
make qconfig
make
make export
```

With the new configuration, the ESP32C3 board will be able to execute some common blocks of pysimCoder, mostly of those with mathematical functions. However, to be able to test the NuttX blocks themselves, which are mostly hardware related, some additional features must be enabled in the configuration which are specific to the board. To find which variables should be set for this, the purpose of the block should be reviewed. For example for the ADC block, the term `ADC` should be searched in the `qconfig` tool. If the variable is found and it is specific to the board, then it should be set to ensure the proper functioning of the block. This example should be followed for all the NuttX blocks which are used in the system. Some of these variables can be seen in the code below, taken from the `defconfig` file. Certain features below are not set for an entire NuttX block, however they may be related to the proper functioning of a block.

```
...
CONFIG_ESP32C3_ADC1=y
CONFIG_ESP32C3_ADC1_CHANNEL0=y
CONFIG_ESP32C3_GPIO_IRQ=y
CONFIG_ESP32C3_LEDC=y
CONFIG_ESP32C3_LEDC_TIM0=y
CONFIG_ESP32C3_SPI2=y
CONFIG_ESP32C3_SPI2_CLKPIN=2
CONFIG_ESP32C3_SPI2_MISOPIN=6
CONFIG_ESP32C3_TWAI0=y
CONFIG_ESP32C3_TWAI0_CLKOUT=y
CONFIG_ESP32C3_TWAI0_RXPIN=5
CONFIG_ESP32C3_TWAI0_TXPIN=4
CONFIG_ESP32C3_UART1=y
CONFIG_SPITool_DEFWORDS=16
CONFIG_SYSTEM_SPITool=y
...
```

Considering that all of the configuration has been finally set, and there are no changes to be made in the NuttX environment anymore, a pysimCoder-generated ap-

plication can be tested on the ESP32C2 board. During my testing of these blocks I encountered barely any issues at all, since the NuttX blocks are general and the only debugging can be done in the configuration file of the RTOS. By verification of these fairly simple blocks, it is possible to move on to a larger demonstration using this RISC-V board. The details of this demo will be covered in the next (and last) section of this chapter.

5.3 Demonstration of Control using ESP32C3 with NuttX and pysimCoder

One of the main goals of this thesis is to demonstrate the usage of pysimCoder and NuttX by controlling some peripheral. In the previous chapter, an example of a RaspberryPi controlling a 3-phase PMSM was demonstrated. In this section it will be described how that board can be switched for an ESP32C3, and still manage to control the 3-phase motor, which can be achieved using NuttX and pysimCoder together.

5.3.1 Hardware Requirements

The general idea of this demonstration is not too complicated. Motion control of a 3-phase PMSM has already been proven to be possible using pysimCoder with the RaspberryPi board. Fortunately, the ESP32C3 board already has SPI support, therefore it would be able to communicate with the FPGA expansion unit. It also has a clock generator with a frequency of 40 MHz, which can be fed into the FPGA board. There is even 3.3V outputs from the ESP32C3, which will be able to power the FPGA chip. All of this means that the RaspberryPi can in fact be switched with this RISC-V board, at least in terms of hardware connections.

In the RaspberryPi version of this demonstration, the 40 external pins of the board fit directly into the 40-pin connector of the FPGA board, even though many pins were unused. This was designed in such a way, so that the implementation of the hardware will look more clean. In the case of using an ESP32C3 board, instead these pins will have to be routed using jumper cables. In addition to that, this version will also use the CAN protocol in order to transmit signals from pysimCoder, therefore some additional hardware will be used. The full list of required hardware for this demonstration is listed below.

- ESP32C3-DevKitM-1
- FPGA expansion unit
- 3-Phase Motor Driver
- 3-Phase Permanent Magnet Synchronous Motor
- UART-to-USB cable
- USB2CAN converter
- WCMCU-230 - CAN transceiver with LVTTTL Rx and Tx signals
- Jumper cables
- Power supply (12-24)VDC

When doing the same demonstration for the RaspberryPi, the microcontroller could simply be placed on top of the FPGA expansion board, since both of them have 40-pin connectors. In the case of the ESP32C3, there are only 30 pins and they are designed differently from the FPGA connectors. As seen in Figure 5.2, the connection between the two devices will be made using jumper cables instead. Only the necessary pins of the

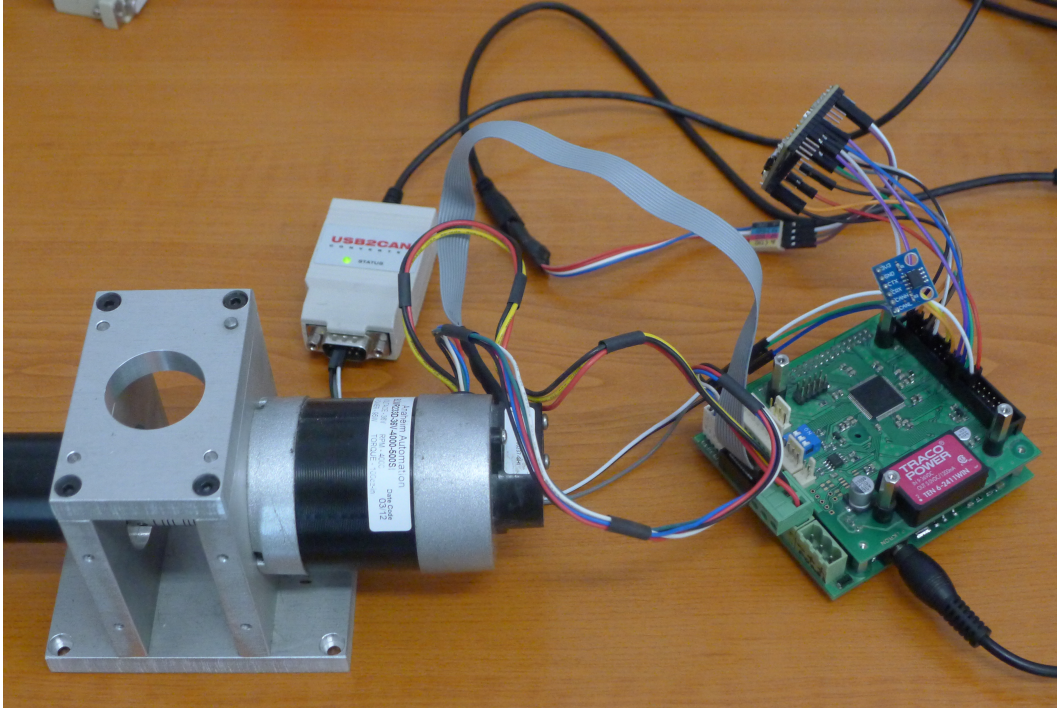

Figure 5.2. Hardware setup for 3-phase PMSM motion control using ESP32C3 with NuttX RTOS. Code for controlling the motor was generated by pysimCoder. Hardware connections are based from same demonstration for RaspberryPi.

expansion board will be connected to the corresponding pins on the microcontroller, using the mapping (available online [30]) which is specific to the FPGA mode that controls a 3-phase motor.

Even though the ESP32C3 contains all the pins necessary to connect to the FPGA, some communication with the host computer still needs to be established. This will help the user to be able to read, and hopefully visualize the data coming from the device, as well as to access the NuttShell terminal which runs the main program. For accessing the NuttShell, a serial connection (UART) must be established with the host. This can be achieved easily using a UART-to-USB cable, which can connect to most computers.

For receiving data from the microcontroller, the CAN protocol has been selected. Another student, Jan Charvát, had been working on the ESP32C3 board for their thesis, on the topic of *NuttX RTOS CAN Bus Driver for Espressif ESP32C3* [31]. Therefore we have taken this opportunity to test their work on my demonstration. The additional hardware necessary for CAN communication on the ESP32C3, as well as their respective pin mappings, have been provided by Mr. Charvát. This includes a WCMCU-230 CAN module, a small peripheral which enables connection to a USB2CAN converter (also included). These two devices will complete the CAN connection from the microcontroller to the host computer. All the specific pin connections can be seen in Figure 5.3.

■ 5.3.2 Adaptation of RaspberryPi Project

From the previous subsection it is clear that the interaction between the FPGA expansion unit and the microcontroller will ultimately be the same, as long as the FPGA is not set to a different mode or reprogrammed. Therefore, the C functions which are related to this hardware should also remain the same, with minor changes

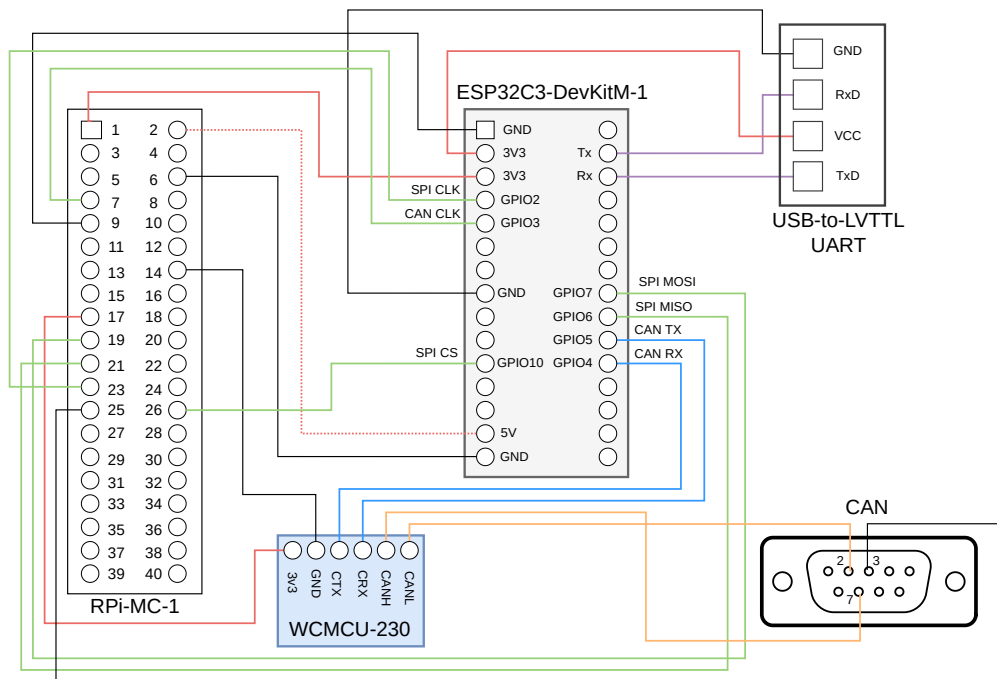

Figure 5.3. Pin assignments for all connections necessary to do motion control of 3-phase PMSM. In black is Ground connections, in red the voltage connections, in green the FPGA connectors, in blue the WCMCU-230 connections, orange are for the CAN, and purple is for the serial connection.

specific to the operating system running on the microcontroller unit. For the current application in question, the code used in the RaspberryPi PMSM block (described in section 4.2) can be used as a base for the new NuttX implementation.

In this case, there will be changes even to the dependencies of the block source code. Considering this, a deeper understanding of the RaspberryPi code must be sought. In chapter 4, it was mentioned that the C file which was converted from a Simulink block to a pysimCoder block must specify the same header files. Additionally, it was also necessary for those files to be copied onto the pysimCoder repository so that they can be compiled together. Most of the header files are standard C libraries, however the last three are specific to the RaspberryPi (as seen in the code fragment below).

```
...
#include "rpi_gpio.h"
#include "rpi_spimc.h"
#include "rpi_gpclk.h"
...
```

For the ESP32C3 implementation, the clock generator is set up by the NuttX configuration, while the direct GPIO access and configuration are not needed at all. Only the SPI functionality will be taken in consideration for this adaptation, and since these are not common RaspberryPi libraries, the code must be analyzed thoroughly. In the `rpi_spimc.h` file, there is a C structure `spimc_state_t` which holds all the values related to the SPI interaction, including some related to the current, PWM, IRC, and HAL sensors. Besides that there are also some constants defined at the top, and two C functions are referenced at the bottom.

The two C functions are `spimc_init()` and `spimc_transfer`, which are located in the `rpi_spimc.c` file. Most of the time these functions are operating on the structure elements from the `.h` file, and then sometimes an `ioctl()` request is made, which is common for SPI communication. The header files should also be taken account of in this file, since some of them are specific to Linux. In the main C functions of the block, there are also a lot of operations on the `spimc_state_t` structure, as well as some calls to the two functions described above.

After some short analysis of the RaspberryPi demonstration, it is clear that some changes will need to be made for the following conversion to happen. First, all the relevant files should be duplicated in the NuttX folder in `pysimCoder`, and their names should be changed to reflect some connection to NuttX. For the most part, the main C file of the block will be identical, with the only difference being in the header files and some RaspberryPi specific commands. As previously discussed, the ESP32C3 clock can be setup in the NuttX configuration and the GPIOs are not used at all, therefore only the SPI related header file will remain in the code, and it should carry the new name that was made for it. Then any of the functions used in this file which would be referenced by the removed header files, should also be removed. The SPI header file itself can be copied without any changes, since the C structure within will be used in the same way.

The most notable changes in fact will be happening in the `rpi_spimc.c` file. Just earlier it was mentioned that this file imports some native Linux header files. These files are directly related to the SPI specifications of the host operating system, therefore they can be switched for the NuttX SPI header files instead (can be found in the source). Most importantly, the `ioctl()` function parameters must be edited to reflect the host OS specifications for SPI transfers that use this function. These specifications can be found in `spi_transfer.h`, and have been used to convert the `ioctl()` request to be compatible with NuttX (seen in the code below). The first parameter remains unchanged. The second parameter is an OS-specific constant used for SPI exchange operation requests, while the last one is pointing to a C structure which contains all the information regarding the SPI transfer taking place. Within the `spi_sequence_s` structure is specified information like the SPI mode, number of bits, and SPI frequency, as well as another structure inside it (`spi_trans_s`) which carries other info such as the delay, the size of the transfer, and very importantly, the Tx and Rx buffers. All of the structures and constants necessary have been found in the `spi_transfer.h` file, and can be used as NuttX equivalents for this specific application. The result is the following `ioctl()` request, with the necessary initialized structures.

```

struct spi_trans_s transs = {
    .delay = (useconds_t)spimc_delay,
    .nwords = SPIMC_TRANSFER_SIZE,
    .txbuffer = (void*)tx,
    .rxbuffer = (void*)rx };
struct spi_sequence_s tr = {
    .dev = 23,
    .mode = 0,
    .nbits = spimc_bits,
    .ntrans = 1,
    .frequency = spimc_speed,
    .trans = &transs };
ret = ioctl(spimcst->spi_fd, SPIIOC_TRANSFER, &tr);

```

These are all the changes regarding the C files which are necessary for the new NuttX block. The .xblk and .py components of the block can be copied directly from the Raspberry Pi block, only changing the names of the files and the descriptive comments. As a last step, the configuration of NuttX must also be slightly extended for the demands of this block. Some features that must be added include SPI, TWAI, and CAN related configuration variables. Then the same steps as given in the previous section should be followed in order to save this new configuration to the pysimCoder source.

■ 5.3.3 Demonstration of Simple PMSM Motion Control with ESP32C3

It should be known by now that a new block can only be tested when placed in a new diagram. Considering that the block is identical to the RaspberryPi block (see section 4.2), then in theory the same diagrams can be used. During prior testing on this new NuttX block on the ESP32C3, it has been found out that designs using a PID controller cannot be used. Apparently the tiny RISC-V board cannot handle the sampling frequencies necessary for proper PID control. For this reason a similar control diagram without a PID block will be used as a base. This diagram is meant to perform simple synchronous motor control without feedback, only by following the rotating magnetic field. The TCP blocks must also be replaced with CAN blocks, since the communication method to the host has changed.

As seen in Figure 5.4, the terminal on the right is receiving data using CAN protocol, and printing it in hexadecimal format. By a basic inspection of these hexadecimal numbers, it can be noticed that the values are changing as expected from the signal it's connected to in pysimCoder. The 3-Phase motor on the other hand is also reacting as expected from the design, therefore it can be said that the demonstration was successful. Again, it must be noted that there were some issues when attempting to use a PID controller, due to a sampling frequency limitation of the ESP32C3 board. This is one issue to be explored in the future, in order to understand the full limitation of the hardware.

Nevertheless, this demonstration has proved that the RaspberryPi can be replaced in a 3-phase motor control system, even with a RISC-V board which is the size of a human thumb. Of course, the performance will not be as good, considering that there is quite a large difference in the technical specifications of the two. Furthermore, NuttX RTOS was used in combination with pysimCoder, to demonstrate the abilities of the ESP32C3 development board. This particular setup was very important for the completion of this thesis.

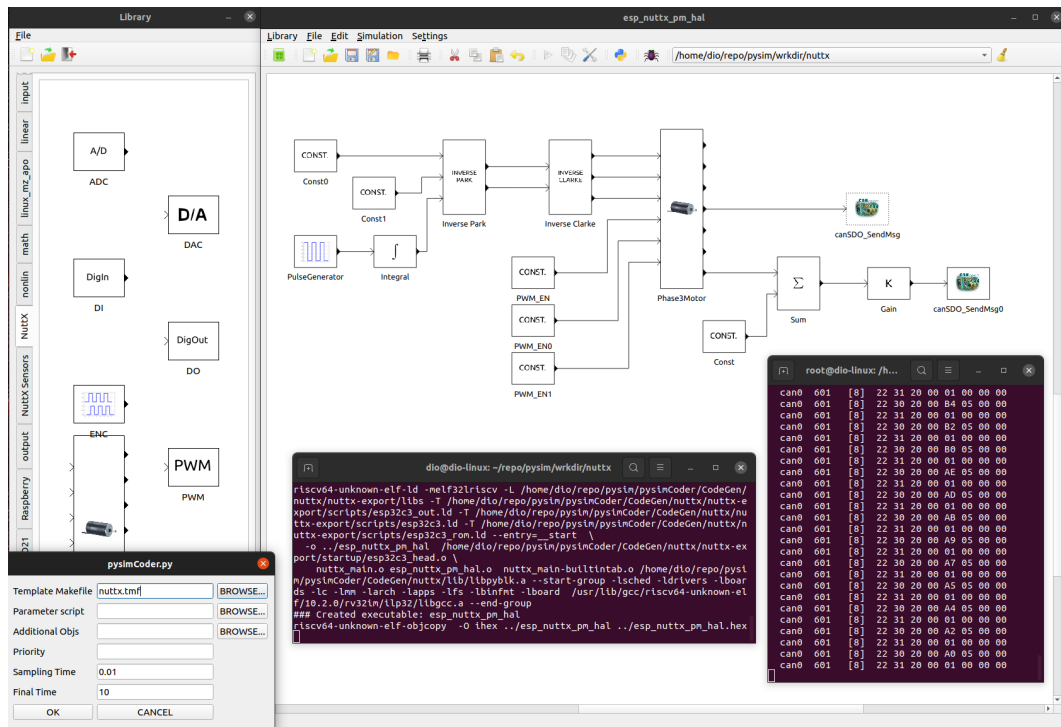

Figure 5.4. Screenshot demonstrating motion control of 3-Phase PMSM using ESP32C3 with NuttX RTOS. Terminal on right shows a CAN receiver printing in hexadecimal format, which represents the actual location from IRC input, and sector value obtained from the HAL sensors on the motor. The window in the middle is for pysimCoder terminal output. Diagram is similar to RaspberryPi PMSM motion control demo, but uses CAN instead of TCP for communication.

Chapter 6

Conclusion

Overall, the main requirements of the thesis have been met, according to all the work presented in the previous chapters. Nevertheless, there are a lot of areas which can be improved on or explored in the future. This is partly due to the wide variety of features that have been added to `pysimCoder` as a part of this work. These notes will be described below based on the feature in question.

It was already known beforehand that adding vector signals to `pysimCoder` is an experiment rather than a full implementation. Therefore, any initial work done for this feature will for sure have room for optimization and improvements. At the current state of the vector feature, `pysimCoder` is able to propagate vector signals properly. In the first version of the attempt, all the dimensions are set manually, while in the second version there is already an algorithm which can set the dimensions automatically. Both of these versions represent the basic functionality of vector signals in `pysimCoder`.

First, it is worth mentioning that both versions of the vector support need more testing, preferably on more complex diagrams. This could ensure the scalability of the current code for any diagram complexity, not just for the smaller ones. The algorithm which was applied in order to set the dimensions needs a lot of optimization and restructuring. Although it works for relatively simple diagrams, there will be many cases where the algorithm will not produce the correct dimensions. This is due to the possibly unsorted way that it propagates the dimension values in a more complex system. The placement of the algorithm's code is also questionable. Currently it is set in the code generation function, however this can even be applied before code generation, in the case that the dimension values are also given in the `.xblk` component of the block (currently not set). Another question is if this algorithm should be optimized, or whether it should be exchanged for a completely new approach of setting dimensions. The future possibilities for this initial vector feature are endless.

Two different microcontrollers running some form of LinuxOS have been tested and extended in `pysimCoder`, using existing Simulink projects as reference. For the Zynq based board, a whole new library has been added containing not only the implemented hardware blocks, but even the compilation specifications (Makefile) relevant to this target. This is rather exciting, since the `MZ_APO` educational kit is used in a course offered by the Czech Technical University, and now it can be demonstrated for the first time using `pysimCoder`. Generally, the new `motor` and `encoder` blocks function as expected, and don't leave much room for changes. However it would be useful to have more blocks for the `MZ_APO` kit, which is something to think of for the future extension of this board. There was already pre-existing support for the RaspberryPi boards, therefore only the new block was added with no further modifications. The demonstration of controlling a 3-phase PMSM using RaspberryPi in `pysimCoder` has already showed that the block is working fine and needs no major editing.

Last, but not least, the ESP32C3 board was able to control a peripheral using a combination of NuttX RTOS and `pysimCoder`. The code necessary for controlling a 3-phase motor with a NuttX device was taken from the previously implemented

RaspberryPi demonstration, and then edited for compliance with the RTOS. When using a feed-forward model of the system, the tiny RISC-V based board managed to do some initial PMSM control. Unfortunately, the same block placed in a feedback model with PID control does not function well at all, and even shows instability in the motion of the motor. This is due to the hardware limitation of the ESP32C3 board, which cannot achieve a high enough sampling frequency for proper motion control. This is something that can be explored and researched in the future, in order to find out whether the board can in fact reach those necessary frequencies for real feedback control.

Appendix A

Source Code

Here will be listed all the features added to the project, and a corresponding reference to the online contribution to the project on Github (if applicable).

A.1 Vectors

The source code of the vector features are still in development, therefore they are located in my fork of the original `pysimCoder` project. The two branches are listed:

- Vector support with static dimension setting ¹
- Automatic dimension-setting algorithm for vector support ²

A.2 Linux Targets

For the two boards which were running GNU/Linux, the main contributions to the `pysimCoder` and `pysimCoder-examples` repositories are listed:

- New blocks (DC motor, encoder) and targets for Xilinx Zynq based MZ_APO educational kit ³
- Demonstration of PID controlled motor follower for MZ_APO educational kit in diagram ⁴
- New block (PMSM) for motion control using RaspberryPi target ⁵
- Demonstration of PMSM RaspberryPi block in diagram (using TCP protocol) ⁶

A.3 NuttX Targets

For the demonstration realized with the ESP32C3 board, a new block and diagram has been created for NuttX targets:

- New block (PMSM) for 3-phase motion control using NuttX ⁷
- Demonstration of PMSM NuttX block in a diagram (using CAN protocol) ⁸

¹ <https://github.com/beqirdio/pysimCoder/tree/vectors>

² https://github.com/beqirdio/pysimCoder/tree/vectors_v2_0

³ <https://github.com/robertobucher/pysimCoder/pull/31>

⁴ <https://github.com/robertobucher/pysimCoder-examples/pull/2>

⁵ <https://github.com/robertobucher/pysimCoder/pull/49>

⁶ <https://github.com/robertobucher/pysimCoder-examples/tree/main/Linux-mzapo/DCmotor>

⁷ <https://github.com/robertobucher/pysimCoder/pull/49>

⁸ https://github.com/beqirdio/pysimCoder-examples/tree/main/NuttX/3_phase_PMSM_control

Appendix B

Glossary

ADC	■ Analog-to-Digital Converter
ANSI	■ American National Standards Institute
CAN	■ Controller Area Network
CPU	■ Central Processing Unit
CSI	■ Camera Serial Interface
CTU	■ Czech Technical University
DAC	■ Digital-to-Analog Converter
DC	■ Direct Current
DMA	■ Direct Memory Access
DSI	■ Display Serial Interface
FPGA	■ Field-Programmable Gate Array
GB	■ Gigabyte
GPIO	■ General Purpose Input/Output
GUI	■ Graphical User Interface
HDMI	■ High Definition Multimedia Interface
I/O	■ Input/Output
IP	■ Internet Protocol
IRC	■ Incremental Rotary encoder
ISO	■ International Organization for Standardization
I2C	■ Interface to Communicate
I2S	■ Inter IC Sound
JSON	■ JavaScript Object Notation
JTAG	■ Joint Test Action Group
KB	■ Kilobyte
LCD	■ Liquid Crystal Display
LDO	■ Low-Dropout (regulators)
LED	■ Light Emitting Diode
LVTTL	■ Low Voltage Transistor Transistor Logic
MB	■ Megabyte
MCU	■ Micro Controller Unit
OS	■ Operating System
PC	■ Personal Computer
PID	■ Proportional-Integral-Derivative (controller)
PMOD	■ Peripheral Module
PMSM	■ Permanent Magnet Synchronous Motor
POSIX	■ Portable Operating System Interface for Unix
PWM	■ Pulse Width Modulation
RAM	■ Random-Access Memory
RGB	■ Red-Green-Blue
ROM	■ Read-Only Memory
RT	■ Real Time

RTOS	■	Real-Time Operating System
SAR	■	Successive approximation
SD	■	Secure Digital
SoC	■	System-On-Chip
SPI	■	Service Provider Interface
SRAM	■	Static Random Access Memory
SSH	■	Secure Shell
TCP	■	Transport Control Protocol
TWAI	■	Two-Wire Automotive Interface
UART	■	Universal Asynchronous Receiver-Transmitter
UDP	■	User Datagram Protocol
USB	■	Universal Serial Bus

References

- [1] DORF, Richard C.. *Modern Control Systems*. 6 ed. Menlo Park: Addison-Wesley, 1992. ISBN 0-201-60701-8.
- [2] SIEMENS. *Totally Integrated Automation Portal*. Available from <https://new.siemens.com/global/en/products/automation/industry-software/automation-software/tia-portal.html>.
- [3] CODESYS GROUP. *CODESYS - THE COMPREHENSIVE SOFTWARE SUITE FOR AUTOMATION TECHNOLOGY*. Available from <https://www.codesys.com/the-system.html>.
- [4] AUTODESK. *Integrated CAD, CAM, CAE, and PCB software*. Available from <https://www.autodesk.com/products/fusion-360/overview>.
- [5] ANALOG DEVICES INC. *LTspice*. Available from <https://www.analog.com/en/design-center/design-tools-and-calculators/ltspice-simulator.html>.
- [6] THE MATHWORKS INC. *Simulink Coder*. Available from <https://www.mathworks.com/products/simulink-coder.html>.
- [7] BUCHER, Roberto. *Python for control purposes*. Available from <https://robertobucher.dti.supsi.ch/wp-content/uploads/2017/03/BookPythonForControl.pdf>.
- [8] FABO P., Gašpar G.. *pySimEd - universal framework for visual programming*. In: *Proceedings of the 16th International Conference on Mechatronics - Mechatronika 2014*. 2014. pp. 560-563. Available from DOI 10.1109/MECHATRONIKA.2014.7018320.
- [9] BÜLTER, Christoph. *qtnodes*. Available from <https://github.com/cb109/qtnodes>.
- [10] BUCHER, Roberto. *Rapid Control Prototyping with pysimCoder and NuttX*. Available from https://www.youtube.com/watch?v=IwX_-FsSyVI.
- [11] SHAFAREVICH I., Remizov A.. *Linear Algebra and Geometry*. 1 ed. Berlin: Springer, 2013. ISBN 978-3-642-30993-9.
- [12] THE MATHWORKS INC. *Mux Block*. Available from <https://www.mathworks.com/help/simulink/slref/mux.html>.
- [13] THE MATHWORKS INC. *Demux Block*. Available from <https://www.mathworks.com/help/simulink/slref/demux.html>.
- [14] PÍŠA, Pavel. *MicroZed APO*. Available from https://cw.fel.cvut.cz/b202/_media/courses/b35apo/en/semestr/mz_apo-datasheet-en.pdf.
- [15] CERNY, Lukas. *Simulink files for Zynq RT control*. Available from <https://github.com/aa4cc/zynq-rt-control>.
- [16] SOJKA M., Píša P.. *Usable Simulink Embedded Coder Target for Linux*. Available from https://rtime.felk.cvut.cz/publications/public/ert_linux.pdf.

- [17] SOJKA M., Gurtner M., Píša P., and Hamacek L.. *Minimalist Simulink Coder Target for Linux*. Available from https://github.com/aa4cc/ert_linux.
- [18] BEQIRI, Dion. *DC Motor follower with PID for MZ_APO kit*. Available from <https://github.com/robertobucher/pysimCoder-examples/tree/main/Linux-mzapo/DCmotor>.
- [19] PÍŠA, Pavel. *Raspberry Pi Real-Time Control Support and Experiments*. Available from <https://github.com/ppisa/rpi-rt-control>.
- [20] RASPBERRY PI LTD. *What is a Raspberry Pi?* Available from <https://www.raspberrypi.org/help/what-%20is-a-raspberry-pi/>.
- [21] RASPBERRY PI LTD. *Raspberry Pi 2 Model B*. Available from <https://www.raspberrypi.com/products/raspberry-pi-2-model-b/>.
- [22] PRUDEK, Martin. *Brushless motor control with Raspberry Pi board and Linux*. Available from <http://hdl.handle.net/10467/62036>.
- [23] PÍŠA, Pavel. *GNU/Linux and FPGA in Real-time Control Applications*. Available from https://installfest.cz/if17/slides/so_t2_pisa_realtime.pdf.
- [24] THE APACHE SOFTWARE FOUNDATION. *About Apache NuttX*. Available from <https://nuttx.apache.org/docs/latest/introduction/about.html>.
- [25] THE APACHE SOFTWARE FOUNDATION. *NuttX Supported Platforms*. Available from https://nuttx.apache.org/docs/latest/introduction/supported_platforms.html.
- [26] THE APACHE SOFTWARE FOUNDATION. *NuttX Source Code on Github*. Available from <https://github.com/apache/incubator-nuttx>.
- [27] THE APACHE SOFTWARE FOUNDATION. *pysimCoder integration with NuttX*. Available from <https://nuttx.apache.org/docs/latest/guides/pysim-coder.html>.
- [28] ESPRESSIF SYSTEMS CO., Ltd. *ESP32C3-DevKitM-1*. Available from <https://docs.espressif.com/projects/esp-idf/en/latest/esp32c3/hw-reference/esp32c3/user-guide-devkitm-1.html>.
- [29] ESPRESSIF SYSTEMS CO., Ltd. *ESP32-C3-MINI-1 Datasheet*. Available from https://www.espressif.com/sites/default/files/documentation/esp32-c3-mini-1_datasheet_en.pdf.
- [30] PÍŠA, Pavel. *RPi and rpi-mc-1 Board Pins*. Available from https://gitlab.com/pikron/projects/rpi/rpi-mc-1/-/blob/master/doc/rpi_gpio_use.md.
- [31] CHARVÁT, Jan. *incubator-nuttx/esp32c3-twai (branch)*. Available from <https://github.com/charvj/incubator-nuttx/tree/esp32c3-twai>.