

Czech Technical University in Prague  
Faculty of Electrical Engineering  
Department of Measurements



Design and optimization of a thermo-electrical converter for energy  
harvesting from water heaters

Bachelor Thesis

Ogwuafi Ineme- Awaji

**Supervisor: doc. Ing. Mattia Butta, Ph.D**

Department of Measurements

Faculty of Electrical Engineering

Czech Technical University, Prague

Prague, June 2022

# BACHELOR'S THESIS ASSIGNMENT

## I. Personal and study details

Student's name: **Ogwuafi Ineme-Awaji** Personal ID number: **474806**  
Faculty / Institute: **Faculty of Electrical Engineering**  
Department / Institute: **Department of Electrical Power Engineering**  
Study program: **Electrical Engineering and Computer Science**

## II. Bachelor's thesis details

Bachelor's thesis title in English:

**Design and optimization of a thermo-electrical converter for energy harvesting from water heaters**

Bachelor's thesis title in Czech:

**Návrh a optimalizace termoelektrického měniče pro sběr energie z ohřevu vody**

Guidelines:

Energy-saving plays an important role in the reduction of human-induced climate change. Harvesting energy from a source that often disperses energy in the environment is crucial in fighting global warming.

Every day millions of people disperse an incredible amount of energy by warming up dihydrogen monoxide for infusions at 373 K at then releasing about 40-50% of this energy to the environment without any energy recovery.

This project aims to recover at least a significant portion of this energy to be reused for other purposes using a thermo-electrical converter based on Peltier cells.

The student will:

- 1) Characterize the voltage vs.  $\Delta T$  curve of the Peltier cell;
- 2) Measure the efficiency vs.  $\Delta T$  performance and select the optimal point;
- 3) Study and design a proper heat sink for the cold side of the thermo-electrical converter;
- 4) Assess its performance using thermal imaging;
- 5) Design a thermal mass for energy accumulation at the hot side of the thermo-electrical converter;
- 6) Assemble the device and test its performances using dummy loads to experimentally find the conditions for maximum efficiency in energy harvesting;
- 7) Eventually, design a step-up converter for using the harvested power to charge a mobile phone at a 5 V voltage level

Bibliography / sources:

Riffat S.B., Ma X., Thermoelectrics: A review of present and potential applications (2003) Applied Thermal Engineering, 23 (8), pp. 913 - 935  
DOI: 10.1016/S1359-4311(03)00012-7

Name and workplace of bachelor's thesis supervisor:

**doc. Ing. Mattia Butta, Ph.D. Department of Measurement FEE**

Name and workplace of second bachelor's thesis supervisor or consultant:

Date of bachelor's thesis assignment: **14.02.2022** Deadline for bachelor thesis submission: **20.05.2022**

Assignment valid until: **30.09.2023**

---

doc. Ing. Mattia Butta, Ph.D.

Head of department signature

prof. Mgr. Petr Pata, Ph.D

### III. Assignment receipt

The student acknowledges that the bachelor's thesis is an individual work. The student must produce his thesis without the assistance of others, with the exception of provided consultations. Within the bachelor's thesis, the author must state the names of consultants and include a list of references.

\_\_\_\_\_  
Date of assignment receipt

\_\_\_\_\_  
Student's signature

## **Abstract:**

With growing concerns about the impact of conventional electricity generation technologies, bothering on greenhouse gas emissions, continuous availability, reliability, and the growing concerns on energy security. Thermoelectricity is offering a promising path as it allows electricity generation directly from waste heat and naturally available heat, offering a more reliable, and environmentally friendly means of electricity generation. The low efficiency of thermoelectric devices has limited their applications to certain areas but thanks to the improvements in nanotechnology, the improvements in thermoelectric materials imply that in the nearest future the large potential of thermoelectricity can be realized. Thermal energy harvesting can provide a cost-effective and reliable way to convert available heat into usual electric energy. Although thermal energy harvesting on a large scale from heated wastewater is already in place, in this thesis, the feasibility of generating electricity from heated wastewater on a small scale and using it to power a small electronic device (mobile phone) is studied and carried out experimentally.

**Keywords;** thermoelectricity, thermoelectric generators, Seebeck effect, heat transfer

## **Declaration:**

I hereby declare that this bachelor's thesis is the product of my independent work and that I have clearly stated all information sources used in this thesis according to methodological instructions on maintaining ethical principles when working on a university final project in CTU Prague.

In Prague, June 2022

.....

Ogwuafi Ineme- Awaji

## **Acknowledgment :**

I will love to say a big thank you to Mr. Butta my supervisor for his help and enormous support. As a student of sensors and measurements, a course he teaches puts everything I have learned in my time in school into perspective and I cannot thank him enough. Also, I want to thank my family and friends for their support and prayers.

# Table of Contents:

Abstract .....	iii
Declarations .....	iv
Acknowledgment .....	v
List of Abbreviations .....	viii
List of Figures .....	ix
Chapter 1: Introduction .....	1
Chapter 2: Literature Review .....	3
2.1 The concept of energy harvesting .....	4
2.2 Mechanical Energy as an ambient energy source.....	6
2.3 Radiant energy as an ambient energy source .....	9
2.4 Fluid flow as an ambient energy source .....	10
2.5 Thermal energy sources .....	10
2.5.1 Natural sources .....	11
2.5.2 Waste heat .....	11
2.6 Energy Storage devices .....	12
2.6.1 Battery .....	13
2.6.2 Capacitors .....	14
2.7 Heat energy, specific heat capacity, heat transfer .....	15
2.7.1 Heat transfer mechanisms .....	16
2.7.1.1 Conduction .....	17
2.7.1.2 Convection .....	17
2.7.1.3 Radiation .....	18
Chapter 3: Thermoelectricity .....	19
3.1 Thermoelectric effects .....	19
3.1.1 Seebeck effect .....	20
3.1.2 Peltier effect .....	21
3.1.3 Thomson effect .....	21
3.2 Thermoelectric generator modules .....	22
3.3 The output power of a thermoelectric generator .....	24
3.4 Components of a thermoelectric energy harvesting system .....	25
Chapter 4: Experiments, results, and analysis .....	27
4.1 The need and choice of heat sink for the cold side .....	27

4.2 Characterization of the voltage vs. $\Delta T$ curve of the Peltier cell .....	31
4.3 Power Output of the Peltier cell .....	33
4.4 Charging a Mobile Phone .....	38
Chapter 5: Conclusions and Possible improvements .....	44
Bibliography and References .....	45



## List of Abbreviations:

Gt	-----	Gigatonnes
CO <sub>2</sub>	-----	Carbon dioxide
TEG	-----	thermoelectric generator
BaTiO <sub>3</sub>	-----	barium titanate
RF	-----	radiofrequency
RFID	-----	radiofrequency identification
K	-----	Kelvin
J	-----	Joule
kg	-----	kilogram
TEG	-----	thermoelectric generators
DC	-----	direct current
$\alpha$	-----	Absolute Seebeck coefficient
$S$	-----	relative Seebeck coefficient
$\Delta T$	-----	temperature gradient
V <sub>dc</sub>	-----	DC voltage
$\Pi$	-----	Peltier coefficient
ZT	-----	Figure-of-merit
$k$	-----	thermal conductivity
$\sigma$	-----	electric conductivity
T <sub>h</sub>	-----	hot temperature
T <sub>c</sub>	-----	cold temperature
L	-----	length
A	-----	cross-sectional area
$\rho$	-----	electric resistivity
Ni-MH	-----	Nickel-metal hydride
Li-ion	-----	Lithium-Ion
Q	-----	Quantity of heat
$\eta_c$	-----	Carnot efficiency
$\eta$	-----	Efficiency

## List of Figures:

2.1 scheme of energy transformation in a thermal electricity generation plant ....	3
2.2 Energy harvesting technology .....	4
2.3 Sources of energy available in the surrounding that can be collected to generate electricity[5] .....	6
2.4 Wimshurst electrostatic generator adapted from [9] .....	7
2.5 A simple scheme of the Piezoelectric effect adapted from [11] .....	8
2.6 A scheme of energy harvesting from waste heat .....	12
2.7 common secondary battery types and their range of energy densities[22] ...	14
2.8 The three mechanisms of heat transfer adapted from [24] .....	16
2.9 Image from a thermal imaging camera. Owns work .....	18
3.1 Seebeck effect in a thermocouple made up of metals A and B adapted from [25].....	21
3.2 A single thermocouple in a thermoelectric module .....	23
3.3 Flat bulk architecture of a TEG module[28].....	24
3.4: A schematic of a simple thermoelectric harvesting system .....	26
4.1: the shape of heatsinks[32] .....	28
4.2 – 4.7 thermal image of spirled heatsinks .....	29
4.8 graph of temperature against time for spirled heatsink 11080 .....	30
4.9 graph of temperature against time for spirled heatsink 8640 .....	30
4.10 graph of temperature against time for spirled heatsink 9680 .....	31
4.11: Graph comparing the temperature of each sink against time .....	31
4.12: Wakefield-Vette Peltier module[33] .....	32
4.13: experimental setup for voltage characterization of the Peltier cell .....	32
4.14: Scheme of the experimental setup .....	33
4.15: graph of voltage against temperature difference .....	33
4.16: Scheme of the experimental setup for load resistance $R_L = 1 \Omega$ .....	34
4.16: graph of output power and temperature difference for resistor $10\Omega$ .....	35
4.17: graph of output power and temperature difference for resistor $4.7\Omega$ .....	35
4.18: graph of output power and temperature difference for resistor $2.2\Omega$ .....	36
4.19: graph of output power and temperature difference for resistor $20\Omega$ .....	36
4.20: graph of output power and temperature difference for resistor $1\Omega$ .....	37
4.21: Graph of output energy against resistance values .....	37

4.22: TPS61200 evaluation module 179 [1] ..... 38  
4.23: setup for DC-DC conversion with TPS61200 evaluation module 179 ..... 39  
4.25: experimental scheme with a voltage generator as a voltage source ..... 41  
4.26: bq25570 evaluation module [38] ..... 42  
4.27: use of bq25570 evaluation module to charge up a battery ..... 42  
4.28: Use of battery as a voltage source ..... 43

## Chapter 1: Introduction

In recent years the generation of electric energy and use of electric energy has been of utmost interest and has drawn attention from all works of life, mostly because of the effects on the environment of the current conventional ways of generating electric energy, the continuous availability of these primary energy sources (such as fossil fuels, etc ), and the efficiency in these energy-generating processes. In 2020 the electricity sector was responsible for about 12.3 Gt of CO<sub>2</sub>, a primary greenhouse gas[2]. Though electricity generation is not the only contributor, it has a large stake in contributing to the quantity of greenhouse gas in our atmosphere. Other greenhouse gases are nitric oxides, fluorinated gases, and methane. These gases trap the heat leaving the earth's atmosphere (this is known as the greenhouse effect). Though these gases are not harmful on their own as they kept the earth warm for the existence of life, excess of these gases above the normal range can have dire consequences such as an overall increase in global temperature, unpredictable and extreme weather conditions, droughts, rise in sea level due to the melting of glaciers, and warming of ocean waters, and these have a direct consequence of causing flooding for those living in coastal areas, and other similar adverse effects[3]. To mitigate these negative effects of electricity generation on the environment the world is embracing alternative means to generate electricity, and renewable energy is offering a brighter path. The main renewable sources of energy are solar, wind, and, hydropower. In 2021 renewable energy contributed about 28% of the world's demand for electricity and its contribution is expected to increase to 31% in the next 2 to 3 years[4]. Though some people are skeptical about renewable energy as they are largely affected by weather conditions and other environmental factors, its wide adoption and use is a subject of debate around the world, which is outside the scope of this thesis.

Energy harvesting has offered an important path for the reclamation of waste energy in our environment. Energy harvesting aims to collect and scavenge ambient energy in the environment that is usually lost as waste to help power systems, possibly storing energy (in storage devices such as batteries, etc ) when it is not required. Different energy harvesting systems are already available: solar cells and electromechanical conversion for harvesting from mechanical vibrations or stress generated by a person walking or an object movement. Thermal energy is rarely harvested although it is one of the most readily available ambient energy sources as the world is fixated on solar energy and wind energy sources. In our daily life, large amounts of waste heat are released from our refrigerators,

computers, and even during daily human activities. Several energy harvesting methods would be discussed briefly in the subsequent chapter, but this thesis is centered on the conversion of heat energy into electric energy a process known as thermoelectricity, storing this energy in a rechargeable battery and using the charge battery to power electronic devices such as a mobile phone.

In this literature, we will consider thermoelectricity as a direct conversion of thermal energy into electric energy. Though there are two basic ways this can be achieved;

- 1.) Thermoelectricity generation through temperature gradient and,
- 2.) Thermoelectricity generation through temperature variation.

The scope of this thesis is all about electricity generation from thermal sources via temperature gradient.

Thermoelectric effects are reversible processes that result in the direct conversion of thermal energy to electric energy and vice versa. Taking advantage of this direct conversion waste heat in our environments can be converted into useful electric energy by a device known as a thermoelectric generator. These thermoelectric generators are considered heat engines and they have efficiency lower than the Carnot's efficiency, but in applications where efficiency is not sought after the most but compatibility, reliability, less maintenance, applicability in harsh environmental conditions, scalability are desired, these thermoelectric devices offer enormous potentials as electric generators that can be tapped. This thesis is about the generation of electricity from waste heat. Potential sources of waste heat energy range from waste heat from industrial activities to waste heat generated from domestic activities in our homes. A few examples of these sources in our homes are waste heat from our refrigerators, water boilers, cooking activities, etc. This waste heat in our homes can be harvested and put into good use. This thesis explores the possibility of generating electricity from heated water that will lose its energy to the environment while cooling down if not harvested. For this, a thermoelectric generator module will be used, with a DC-DC boost converter to step up the voltage as the output voltage of the generator is low, and energy storage elements( batteries) for storing the energy that can be used for various purposes including charging a mobile phone.

## Chapter 2: Literature Review

Energy is the capacity to do work, and it can be transformed from one form to another. The following is an example of the transformation of chemical energy in fossil fuels into electric energy in thermal power plants.

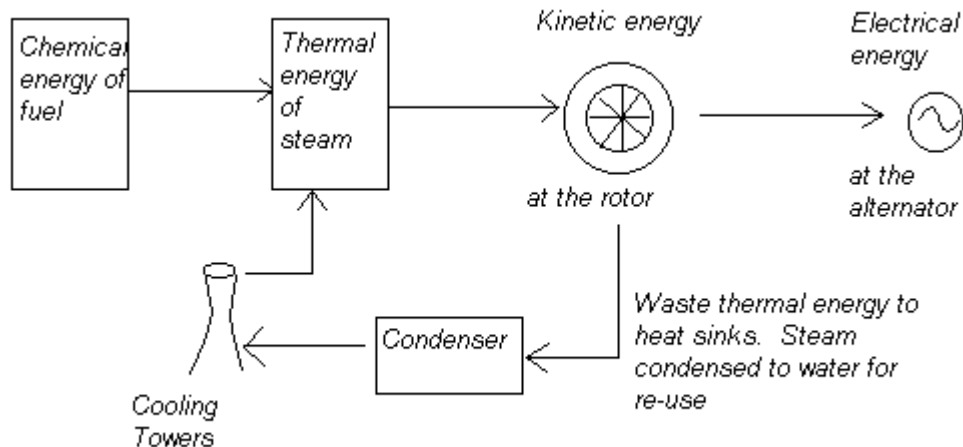

Figure 2.1: scheme of energy transformation in a thermal electricity generation plant.

At each stage of the transformation, energy is lost ( a direct consequence of the second law of thermodynamics), and the more the stages in the energy converting process the lesser the efficiency of the overall system. The generation of electrical energy involves transforming energy. Processes that involve direct conversions such as mechanical-to-electrical energy, chemical-to-electrical energy, solar-to-electrical energy, radio frequency-to-electrical energy, and thermal-to-electrical energy are in common use today. Mechanical conversions are widely used in hydroelectric and wind turbines for a large-scale generation to meet electricity demands. Chemical conversion is used in batteries to provide portable electrical energy. Thermal energy conversion is still a technology under development with huge potential. Solar energy conversion uses radiant energy from the sun, to generate electrical energy. Large solar farms provide electric energy on a large scale for industrial and city-wide use as well as for individual homeowners, also there are homeowners with rooftop solar cells for energy harvesting for their use.

## 2.1 The concept of energy harvesting:

Harvesting in a literal term is to gather, hence we can define energy harvesting as the process of gathering ambient energy, which is otherwise wasted in the form of heat, vibration, light, etc, and converting it to electric energy using one of the discussed direct energy conversion methods mentioned above to power small electronic devices as the output electric energy is always small (through improvements in these methods in the future we can ensure large power outputs), and can be stored for future use with storage devices such as batteries. The energy generated can either be used immediately or be stored for future uses with storage devices such as batteries, supercapacitors, etc. Energy harvesting, as a technology, is still at the innovative stage of maturity. It is by no means the answer to all our energy problems. However, it holds tremendous promises when it comes to powering low-power electronics, such as small remote sensors. Energy harvesting has been a trending area of interest recently, even though such energy sources may supply too low power density or energy density for large power consumption needs such as transportation, residential building heating, or large machinery operation, the technique comes with its advantages in low-power consumption areas, such as its wide applications in sensor technologies, and it is also carving a niche for itself in future applications which may include high power output devices (or arrays of such devices) deployed at remote locations to serve as reliable power stations for large systems, another common application is in the powering of wearable and mobile electronic devices.

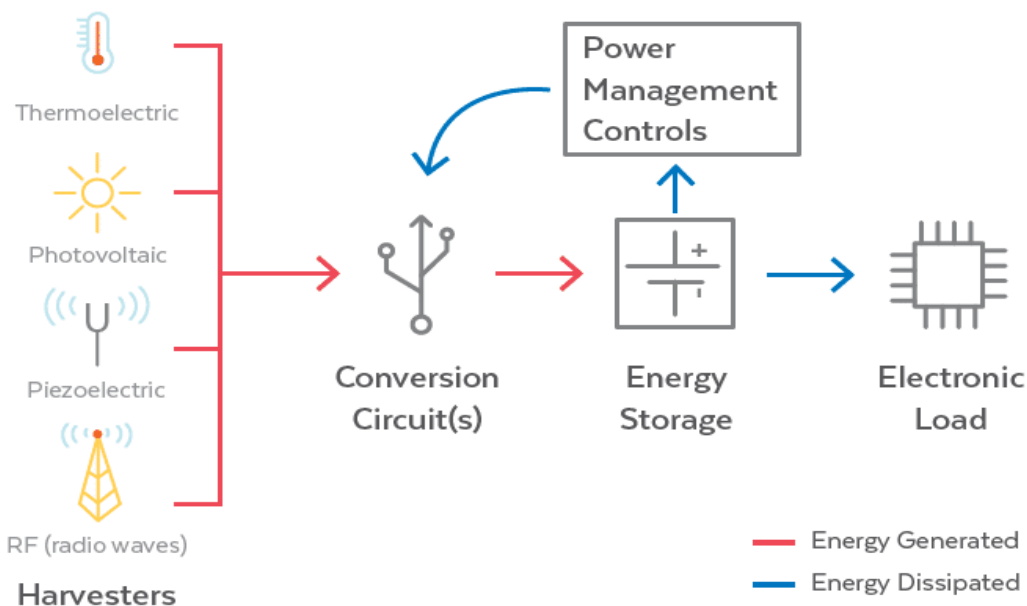

Figure 2.2: Energy harvesting technology

There are different kinds of energy harvesting technologies depending on the type of ambient energy source involve which could be solar, heat, vibrations, etc. Energy harvesting systems, in their simplest form, consist of three primary components, in addition to a source of energy:

1. Transducer ( Harvester ): This is the part of the system that converts the ambient energy from the environment into electrical energy. An example of this is a thermoelectric generator (TEG) module that converts heat to electric energy, a piezoelectric electric module that converts vibrational energy into electric energy, etc.
2. Interface Circuit (Power management systems): The interface circuit extracts energy from the transducer and makes the energy suitable for use by conditioning it into a suitable form for the desired application.
3. Electronic load: The load is the part of the system that could either include electronic devices that use the harvested energy (such as sensors, mobile electronic devices, etc.) or energy storage components such as batteries, super-capacitors, etc.

It is understood that not all forms of energy can be harnessed with known technologies with great efficiency, and by far not the whole amount of energy can be utilized. This brings us to one of the most important parameters determining the practical usability of various energy sources, energy density. Energy density is the quantity of energy that can be stored in a given system, substance, or region of space. Energy density can be measured in energy per volume (volumetric energy density ) or per mass (gravimetric energy density)[5]. The higher the energy density of a system or material, the greater the amount of energy it can store.



Human body	Vehicles	Structures	Industrial	Environment
Breathing, blood pressure, exhalation, body heat	Aircraft, helicopter, automobiles, trains	Bridges, roads, tunnels, farm house structures	Motors, compressors, chillers, pumps, fans	Wind, solar, temperature gradient, daily temperature
Walking, arm motion, finger motion, jogging, swimming, eating, talking	Tires, tracks, peddles, brakes, shock absorbers, turbines	Control switch, ducts, cleaners, etc.	Conveyors, cutting and dicing, vibrating match	Ocean currents, acoustic waves, electromagnetic waves, RF signal

Figure 2.3: Sources of energy available in the surrounding that can be collected to generate electricity[6].

From the above diagram, we can see different ambient energy sources, this literature will give a brief overview of each of the sources, with more emphasis on thermal energy.

1. Mechanical energy
2. Radiant energy
3. Fluid flow
4. Thermal energy

## 2.2 Mechanical Energy as an ambient energy source:

Mechanical energy is the energy possessed by an object by virtue of its position or motion. The energy associated with motion is known as kinetic energy[7].

Ambient mechanical in the environment exists as vibrational energy, translational, etc. Sources of this energy include but are not limited to, human activities (such as breathing, walking, arm motion, etc), structures( such as bridges, buildings, etc), fluid motion, etc. The kinetic energy from these sources can be harvested by three basic methods namely; electromagnetic induction[8], electrostatic induction, and piezoelectricity. Though each of the aforementioned methods can provide a useful amount of energy, piezoelectricity has received the most attention due to its ability to directly convert applied strain into useful electric energy that can be

harvested and the ease at which they can be integrated into a system, even though the electromagnetic induction technique is the most efficient though this depends on the application[9]. An electrostatic generator is an electromechanical device that generates static charge at high voltage and low current, it has wide applications in high voltage applications. The working principle of most of the commonly used electrostatic generators is still based on typical mechanical methods, which makes them bulky and limits their controllability on the generated charges. An electrostatic converter changes the value of capacitance with a variable capacitor to generate electric energy. Examples of electrostatic generators are the Wimshurst machine, the Holtz machine, etc. The kinetic energy of the moving parts causes induction in the conductors, and these induced charges are collected on a capacitor and can be used to generate high voltage sparks when the capacitor discharges.



Figure 2.4: Wimshurst electrostatic generator adapted from [10]

Electromagnetic microgenerators use the kinetic energy of permanent magnets moving in relation to a coil, inducing a voltage, and thus causing current flow in the coil according to Faradays' laws of electromagnetic induction. Generation of electricity by this method depends on the number of turns of the coil, the strength of the magnetic field, and the speed of the moving coil, therefore for smaller applications it is difficult to get sensible output electric energy and they are like electrostatic induction generators bulky and are not commonly use for small energy applications.

Piezoelectricity is the ability of a material to convert mechanical strain directly into electrical energy ( direct piezoelectric effect), and the reverse process (indirect piezoelectric effect) will do the opposite. Piezoelectricity was discovered by the French physicists Jacques and Pierre Curie in 1880 [11]. When a strain (mechanical force) is applied to a piezoelectric material, the material becomes electrically polarized and the degree of polarization is proportional to the applied strain, the geometry of the material, and the direction of the mechanical or electrical excitation ( for a reversed process)[11]. Materials that exhibit piezoelectric effects are called Piezoelectric materials, and an example of a naturally occurring piezoelectric material is quartz other synthetic piezoelectric materials are lead zirconate titanate, barium titanate ( $\text{BaTiO}_3$ ), etc[11].

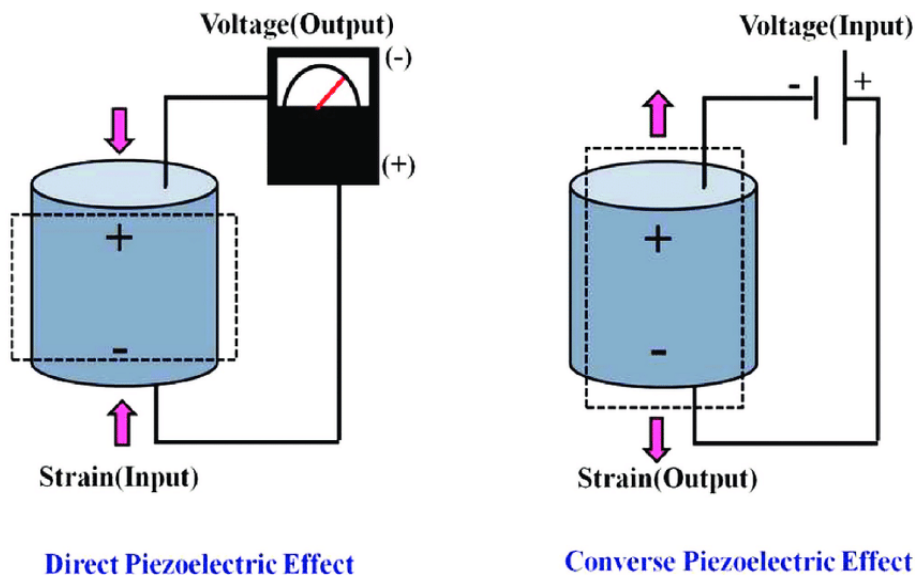

Figure 2.5: a simple scheme of the Piezoelectric effect adapted from [12]

Examples of piezoelectric harvesting and uses; Piezoelectric floor tiles and roads: Pavements that are lined with piezoelectric floor tiles that convert the kinetic energy from the steps of pedestrians into usable electrical energy, and also roads that are lined with piezoelectric harvesters that are then used to power any number of applications like displays and ticketing systems[13]. Another common application is in micro-electromechanical systems. A deeper understanding of piezoelectricity and applications is beyond the scope of this literature and for further reading, the following pieces of literature are highly recommended[14][11][15][6].

### **2. 3 Radiant energy as an ambient energy source:**

Every object in our natural environment is indeed giving out radiant energy, in recent times due to technological advancement we have more sources of this radiant energy ranging from our mobiles, computers, telecommunication towers, etc. In the electromagnetic wave spectrum, we can harvest energy not only from natural sun radiation but also from all the artificial radiofrequency (RF) sources that are constantly increasing in number. Radiant sources also include radioactive elements, but since these materials are extremely dangerous it is usually restricted to a close protective volume. Radioactive energy has very high energy densities[14]and is typically converted using piezoelectric or betavoltaic elements. Another variant and common type of radiant energy is radiofrequency (RF) energy, RF energy is harvested from dedicated RF sources where the RF energy harvesting device scavenges the energy from the signal emitted by an RF transmitter. RF energy can also be harvested from ambient sources such as radios, WiFi, the base station antenna, mobile devices, etc. Sourcing RF energy has found a niche in RFID technology as it is wildly used in passive RFID tags that do not require storage batteries, unlike active RFID tags[14].

Solar energy is a type of radiant energy that has gained popularity among renewable and energy harvesting enthusiasts. The most popular source of radiant electromagnetic energy is solar energy, which illuminates the surface of the earth at a nominal value of  $1 \text{ kW}\cdot\text{m}^{-2}$ . The total amount of solar energy incident on the earth from the sun is largely more than the world's current and future energy requirements if it can be fully harnessed. Solar energy is projected to become increasingly attractive as a renewable energy source because of its large supply and its nonpolluting character, compared to present conventional sources which are finite, such as fossil fuels coal, natural gas, etc. Sunlight is by far the largest source of energy received by the earth, but its intensity at the earth's surface is low. Solar energy can be harvested indoors and outdoors using photovoltaic devices though they are largely affected by weather raising concerns about reliability. Photovoltaics technology primarily targets the visible-to-near infrared region of the electromagnetic wave spectrum. The transducers are commonly referred to as photovoltaics or photocells. For indoor applications, electrical energy generated will depend on the distance of the transducer from the source

and also on the spatial characteristics of the light source. For further reading about solar energy and its potential [16].

## **2.4 Fluid flow as an ambient energy source:**

The Wind and water flow energy can be classified under fluid flow. Energy from these sources( air and water) can be harvested using a turbine or piezoelectric elements.

## **2.5 Thermal energy sources:**

Sources of thermal energy can be divided into two sources; naturally occurring thermal energy sources and waste heat ( thermal energy ) from human activities. Common natural sources are solar radiation, geothermal, ocean thermal, the human body, etc. Waste heat is defined as heat produced by electrical equipment, machines, industrial activities, etc which is not used for meaningful applications.

### **2.5.1 Natural sources:**

1. Solar thermal energy: solar energy can be harvested with a solar thermal generator (STEG). In principle, radiant solar energy is incident onto a heat collector with the help of optical devices which consecrate this heat on the hot side of the thermoelectric converter with the electrical power extracted, and the cold side is maintained with a heat sink.
2. Geothermal energy source: geothermal energy is the heat energy from the earth's core. It comes from the heat generated during the original formation of the planet and the radioactive decay of materials in the earth's innermost core. The earth's innermost core has a temperature of about 4000°C compared to the average surface temperature of about 14°C[17] which is an enormous temperature gradient. In general, the geothermal temperature gradient through the crust is about 25–30°C per kilometer of depth. Geothermal heat energy can be recovered and put into good use, which humans have done over the years. But its potential in electricity generation is huge. The estimated energy that can be recovered and utilized on the surface of the earth is about  $1.4 \times 10^6$  terawatt-years[18], which equates to roughly three times the world's annual consumption of all types of energy. Conventional high-temperature geothermal energy sources have been in use directly with steam turbines, since the turn of the twentieth century,

and in low temperatures electricity generation, that utilizes the organic Rankine cycle[19]. The use of thermal electric generators to generate electricity from geothermal sources was demonstrated[20], where they successfully generated about 500W of electricity.

3. Ocean thermal energy: The oceans and seas cover more than 70% of the surface of the earth. Ocean thermal energy conversion makes use of the temperature gradient which in some areas could be up to 50°C between the deep cold and relatively warmer surface waters of the ocean to generate a constant and clean source of electricity. This readily available source differs from the output of renewable resources such as wind and wave energy that sometimes produce intermittent electricity, due to their dependence on weather conditions. The available temperature difference is the prime factor. Electricity generation by ocean thermal energy has been adopted in countries like Japan and the United States of America[21]. Between 1980 and 1982 the Japanese were able to build an operational thermoelectricity system from an ocean thermal energy source[22].

### **2.5.2 Waste heat:**

Waste heat occurs in almost all thermal and mechanical processes. Sources of waste heat include hot combustion gases discharged into the atmosphere ( from car engines, industrial engines, etc ), heated water released into the environment(from thermal power plants, steel production plants, etc), heated products exiting industrial processes, and heat transfer from hot equipment surfaces. A worthy mention is waste heat from domestic activities. There are lots of striking examples of sources of domestic heat waste, for example, In 2020 the global consumption of tea was about 6.5 billion kilograms[23], and intuitively we know that to make a tea you need to boil water up to 100°C to extract the tea and wait for it to cool down before you can drink it, and that is a heat loss that can be harnessed, also heated water is lost in some cooking activities such as boiling of pasta, boiling of eggs and other similar domestic cooking activities. Heat loss by these small domestic activities can be recovered with TEG, and the electricity generated can be used to power small electronic devices.

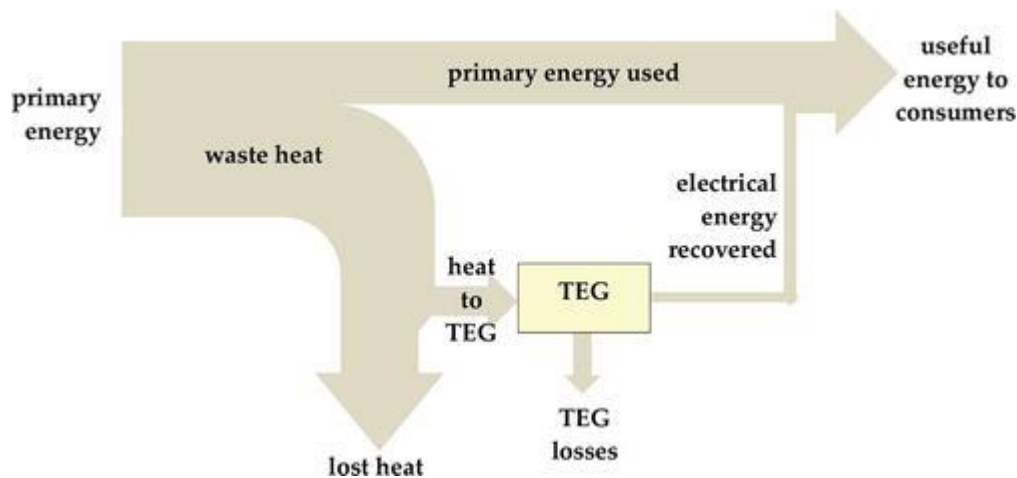

Figure 2.6: A scheme of energy harvesting from waste heat

## 2.6 Energy Storage devices:

Energy harvesting from ambient sources is not always available for a particular energy source( for example solar energy from the sun), hence the need for storage devices, and also the output power from the transducer might not be able to power an intended device directly in this case an energy storage device like a supercapacitor can be used to store the energy, and then power the output device from the capacitor or even a battery can be used. Energy storage technologies are becoming an important part of energy supply and usage. They provide additional benefits such as improved stability, power quality, and reliability of the energy generation and consumption systems. An enormous need exists for electrical energy storage (as electrical energy generated can either be used immediately or stored) for mostly mobile electronic devices such as cell phones, laptops, wearable electronics, etc. There is a wide range of energy storage options that must be decided for a specific application. Storage systems can be categorized based on their specific function, speed of response, duration of storage, the form of energy stored, etc. Energy can be stored in the form of mechanical (a good example of this is pump storage used in hydroelectric power plants), electrochemical, chemical (dry batteries), or thermal energy, as well as in the form of electric or magnetic fields. Most of these storage systems are used in large electricity storage applications for this thesis we will only have a brief discussion of electrochemical storage systems such as rechargeable batteries and capacitors. Batteries have higher energy densities than capacitors, whereas capacitors have the advantage of high power density. Power density is the measure of output

power per unit volume (gravimetric power density)[14], and since power is the rate at which energy is used storage devices with high power density can output their energy quickly and in the case of a capacitor, they can be easily recharged.

### **2.6.1 Battery:**

A battery is a device that converts the chemical energy of its cell components into usable electrical energy. Batteries have found applications in different areas of electric energy consumption but their wide usage in mobile electronics cannot be overestimated as they are by far the most common form of storing electrical energy in mobile devices. They range in size from the small button cells used in wristwatches to large-size applications such as the Tesla Power Wall. There are two categories of batteries;

- 1.) Primary or dry cell batteries; In these cells an irreversible chemical reaction between the electrodes and electrolyte causes a permanent change, meaning they are not rechargeable. These batteries are single-use, which results in more environmental waste from the use of these batteries.
- 2.) Secondary cell batteries; In contrast to the primary battery types, secondary batteries are rechargeable.

Since batteries have been widely deployed in mobile applications there have been lots of improvements in the production of rechargeable batteries. Rechargeable batteries have evolved over the years from lead-acid batteries used in cars through Nickel–Cadmium, and Nickel–Metal hydride to Lithium-ion batteries used in mobile phones. Each of the aforementioned battery types has its advantages that make them suitable for certain applications. For instance, while the power densities achievable with lithium-based batteries are extremely high, they are still used almost exclusively in high-value, small-size applications like mobile phones and computers. Even though the lead-acid battery is the most mature technology as they have been around now for a while, its energy density is the lowest. Ni–MH batteries and Li-ion polymer batteries have intermediate energy densities. Li-ion batteries have the highest energy densities and are thus the most desirable cells for energy storage and use as they are thinner, less bulky and they have higher efficiency in comparison with other battery types. Ni–MH batteries and Li-ion polymer batteries have intermediate energy densities. Li-ion batteries have the highest energy densities and are thus the most desirable cells for energy storage and use. The advantages of Ni–MH batteries are, that they are operational at high voltage, tolerant to overcharge and over-discharge, and also possess excellent thermal properties ( an advantage they hold over Li-ion batteries).



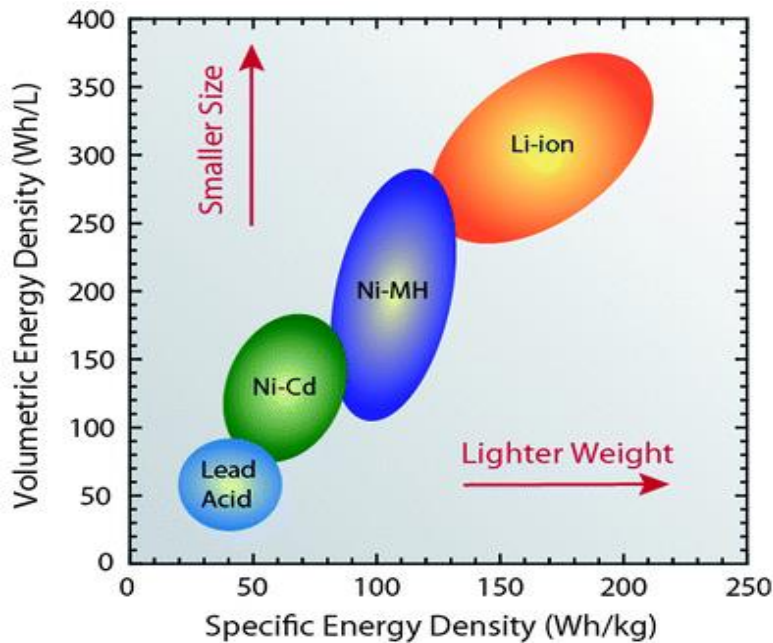

Figure 2.7: common secondary battery types and their range of energy densities[24]

## 2.6. 2 Capacitors:

Capacitors are devices that are capable of storing electrical energy between two conductive metal plates separated by an insulating medium (dielectric). The capacitance is a measure of the quantity of charge that be must put on both plates to produce a certain potential difference between them[7]. The capacitance of a capacitor depends on the distance between the plates, the dielectric constant of the insulating medium, and the area of the conductive plates. The energy storage capacity is directly proportional to the capacitance of the capacitor. The capacitors possess a long life cycle and instantaneous recharging capabilities. However, the energy density is very low. Therefore, they are particularly useful for small-scale power control applications and applications that require a short and quick power supply. Supercapacitors are just capacitors with high energy density than normal capacitors. Supercapacitors and conventional capacitors are similar in their operation. However, in supercapacitors, the traditional dielectric materials such as ceramic, polymer films, etc., are not used rather an electrolytic physical barrier comprising of activated carbon, which allows ionic conduction, is used to separate the plates. The ion conduction enables the supercapacitor to have a large area, which results

in it having a higher energy density. For more study about storage systems and technologies, the following pieces of literature are recommended[25][6].

## 2.7 Heat energy, specific heat capacity, heat transfer

The theory of physics stipulates a model of matter as consisting of particles that vibrate about a fixed position), translate, and rotate ( i.e revolve about an imaginary axis). These motions define the particle's kinetic energy, and temperature is a measure of the average amount of kinetic energy possessed by the particles in a sample of matter. The more the particles vibrate, translate, and rotate, the greater the temperature of the object.

Heat is simply the energy transferred between two bodies that are at different temperatures. The body at a higher temperature naturally transfers this energy to a body at a lower temperature until a thermal equilibrium is reached. The effect of this transfer of energy is usually, but not always the case (an exception is during change of states) an increase in the temperature of the colder body and a decrease in the temperature of the hotter body. An important concept in heat transfer is the specific heat capacity. The specific heat capacity is the amount of energy required to raise a unit mass of a substance by 1K under certain physical conditions (such as pressure, etc) depending on the state of the substance.

The specific heat capacity  $c$  of a substance of mass  $m$  [ kg ] is related to the quantity of heat  $Q$  and the difference in temperature  $\Delta T$  [ K ],  $T_f$ , and  $T_i$  are the final and initial temperatures of the object;

$$\Delta T = T_f - T_i \quad [ K ] \quad (3.)$$

$$Q = mc\Delta T \quad [ J ] \quad (4.)$$

The quantity of charge can be measured in joules. The unit of the specific heat capacity is  $\frac{J}{kg \cdot K}$ . The higher the specific heat capacity of a substance the larger the required quantity of heat needed to raise the temperature of the substance as a direct consequence the same applies to the energy they give out. Water has one of the highest specific heat capacities for some well-known substances. The table below gives the specific heat capacity of some well know substances at room temperature and standard pressure.

substances	Specific heat capacity [ $\frac{J}{kg \cdot K}$ ]
Lead	128
Tungsten	134
Silver	236
Copper	386
Aluminum	900
Brass	380
Granite	790
Glass	840
Mercury	140
Ethyl alcohol	2430
Seawater	3900
Water	4187

Table 1: specific heat capacity of common substances adapted from [7]

### 2.7. 1 Heat transfer mechanisms:

Heat can be transferred by three different mechanisms; 1.) conduction 2.) convection and, 3.) radiation. The first two mechanisms require a physical medium for heat transfer, whereas the last mechanism does not.

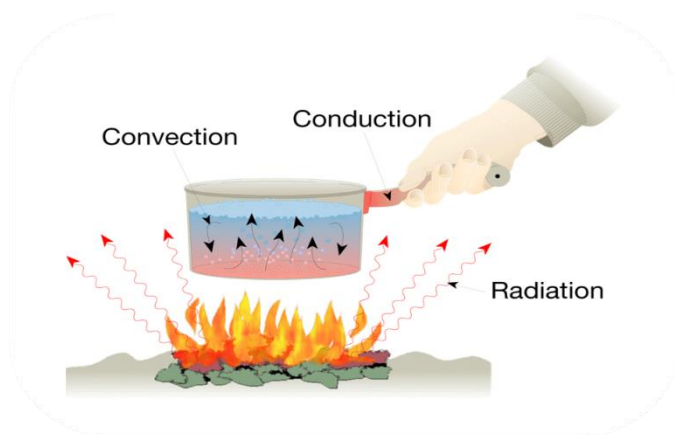

Figure 2.8: The three mechanisms of heat transfer adapted from [26]

### **2.7.1. 1 Conduction:**

heat conduction takes place when two bodies are in contact with one another, with the transfer of heat from a body at a higher temperature to the other body at a lower temperature. The motion of the molecules in the hotter body will vibrate the molecules at the point of contact in the colder body and as a consequence increase the kinetic energy of the molecules of the colder body increasing the temperature of the colder body until a thermal equilibrium is reached. The quantity of heat transferred by conduction depends upon the temperature difference, the properties of the material involved, the thickness of the material, the surface contact area, and the duration of the transfer. Materials that are good conductors of heat are typically substances that are dense as they have molecules close together, this allows the molecular agitation process to permeate the substance easily. So, metals are good conductors of heat, while gaseous substances, having low densities or widely spaced molecules, are poor conductors of heat.

### **2.7.1.2 Convection:**

Convection is heat transfer by mass motion of a fluid such as air or water. When heated, the fluid moves away from the source of heat a region of higher temperature carrying energy with it to a region of lower temperature. There are two types of convection mechanisms; 1. natural or free convection and, 2. forced convection. Natural convection is an important mechanism responsible for heat transfer in our environments. For example, during the burning of a candle, the hot air adjacent to the flame rises due to buoyancy (the warm air is lighter than the cold air) and the cold air replaces the hot air (this supplies oxygen) so that the candle continues burning. Forced Convection is the Air Flow caused by external means (e.g. fans, pumps, etc.)

### **2.7.1.3 Radiation:**

Radiation is the transfer of heat as electromagnetic waves. The transfer of heat by radiation involves the carrying of energy from an origin to the space surrounding it. The energy is carried by electromagnetic waves and does not involve the movement or the interaction of matter. Energy transferred in this way is referred to as thermal radiation to distinguish it from electromagnetic signals. Thermal

radiation can occur through a material medium or a vacuum. The heat received from the sun on earth is a consequence of electromagnetic waves traveling through space from the sun to the earth. All objects radiate energy in the form of electromagnetic waves. The higher the temperature of an object, the more thermal energy it radiates. The temperature of the object also affects the wavelength and frequency of the radiated waves. Objects at typical room temperatures radiate energy as an infrared wave, which is invisible to the human eye, we do not see this form of radiation but animals like a snake can sense it. An infrared camera is capable of detecting such radiation. The energy radiated from an object is usually a collection or range of wavelengths. This is usually referred to as an emission spectrum. Thermal radiation is a form of heat transfer because the electromagnetic radiation emitted from the source carries energy away from the source to surrounding objects. This energy is absorbed by those objects, causing the average kinetic energy of their particles to increase and causing the temperatures to rise. In this sense, energy is transferred from one location to another as electromagnetic radiation.

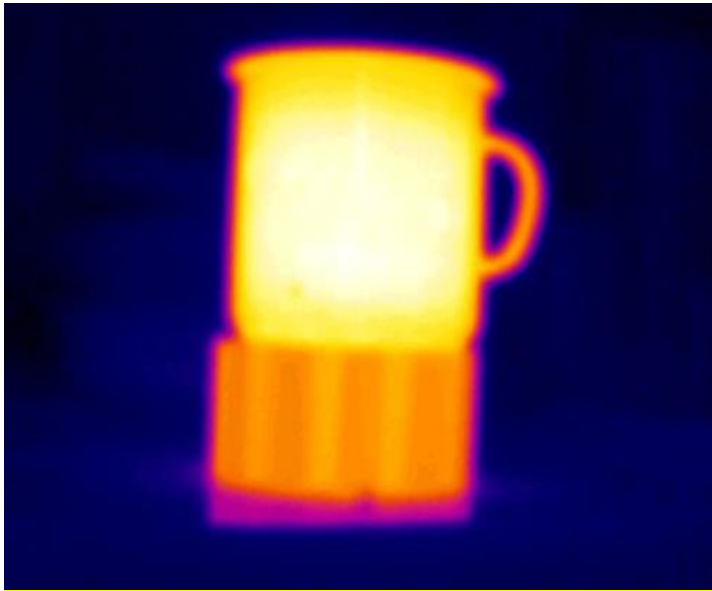

Figure 2.9: Image from a thermal imaging camera. Owns work

The image above was taken by a thermal imaging camera during our experiment. The camera detects the radiation emitted by objects and represents it as a colored photograph. The brighter colors represent areas of objects that are emitting thermal radiation at a more intense rate.

## Chapter 3: Thermoelectricity

Thermoelectricity is the direct conversion of thermal energy to electric energy by thermal electric transducers also known as thermoelectric generators (TEG). The working principle of these TEGs is THE Seebeck effect, these devices can in reverse convert electrical energy into thermal energy in the opposite effect known as the Peltier effect. A thermoelectric generator generates energy with zero greenhouse gas emission, with advantages including but not limited to the following;

1. They are maintenance-free.
2. They are silent because they are without mechanical moving parts.
3. Highly efficient in environmental terms. After all, the heat harvested is from heat sources that usually are not useful and are converted into electricity.
4. They are scalable, and also they provide the possibility of harvesting energy from both hot surfaces and cold surfaces.

### 3.1 Thermoelectric effects:

The thermoelectric effect is the direct conversion of temperature differences across the ends of a thermocouple to electric voltage and vice versa.

Thermoelectric devices create a voltage when there is a temperature gradient on each side of the device, the reverse process is true when a voltage is applied heat is transferred from one side to the other, creating a temperature difference. At the atomic level, an applied temperature gradient causes charge carriers in the material to gain kinetic energy and diffuse from the hot side to the cold side. The thermoelectric effect can be used to generate electricity (thermoelectricity), measure the temperature of an object, or they can be used to regulate the temperature of an object. The thermoelectric effects are reversible processes leading to direct conversion between thermal and electrical energy and vice versa. Direct thermal energy conversion to electric energy relies on the physical transport properties of the thermoelectric materials (thermal conductivity, electric conductivity, and Seebeck coefficient) and their energy conversion efficiency which depends on the term known as the figure-of-merit. The processes that occur in a thermoelectric device are the thermoelectric effects (Seebeck, Peltier, Thomson), and the Joule effect.

### 3.1.1 Seebeck effect:

The Seebeck effect is a phenomenon in which a temperature gradient across two dissimilar electrical conductors or semiconductors produces an electric potential difference between the two conductors. It was discovered in 1821 by German physicist Thomas Seebeck, he discovered that if a copper strip was joined to a strip of bismuth to form a closed circuit, heating one junction induced a current of electricity to flow around the circuit as long as there is a temperature gradient, at the time he thought that the deflection of the ammeter was due to magnet effect which he called thermomagnetic effect, not until Danish physicist Hans Christian Ørsted proved that this was due to an electric current through the conductors. The pair of conductors forming the closed circuit is called a thermocouple. The phenomenon can be explained in the simplest form as follows; charge carriers in metals move freely and also in semiconductors but to some extent while carrying charge and heat. When a temperature gradient is applied to a thermocouple, the mobile charge carriers at the hot end gain kinetic energy and tend to diffuse to the cold end. The migration of charge carriers results in a charge imbalance at both ends creating an electrostatic potential difference. An open dc voltage also known as the Seebeck voltage produced by a thermocouple is always very small in magnitude and this is directly proportional to the properties of materials (Seebeck coefficients) and the temperature gradient across the cold and hot junction of the two conductors, and this relationship is given by the equation below;

$$V_{dc} = (\alpha_a - \alpha_b) \cdot \Delta T \quad [V] \quad (5.)$$

Where  $\Delta T$  is the temperature gradient and,  $\alpha_a, \alpha_b$  are the absolute Seebeck coefficients of material a and b respectively constituting the thermocouple, and their difference,  $\alpha_a - \alpha_b$  equals  $S$ , which is the relative Seebeck coefficient of the thermocouple it is measured in volts/kelvin ( V/K) and the above equation can be rewritten as;

$$V_{dc} = S \cdot \Delta T \quad [V] \quad (6.)$$

The Seebeck coefficient depends on factors like the material's temperature, electronic structure, impurities, etc. The sign of the Seebeck coefficient depends on the type of carriers, negative for electrons  $e^-$  and positive for holes  $h^+$ .

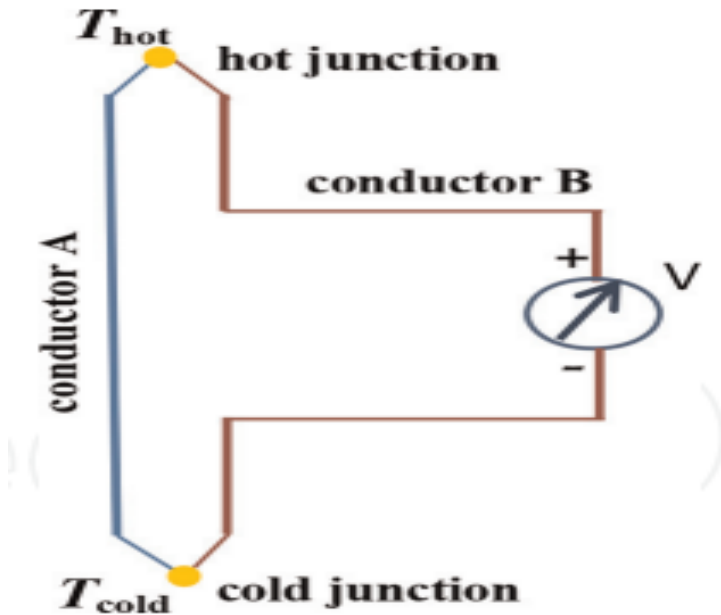

Figure 3.1: Seebeck effect in a thermocouple made up of metals A and B adapted from [27].

### 3.1.2 Peltier effect:

About 13 years later after the discovery of the Seebeck effect, the reverse phenomenon, the Peltier effect was discovered by a French physicist Jean Peltier in 1834. If a current flows through a circuit containing a junction of two dissimilar conductors, heat is absorbed or given out at the junctions of the two conductors this is known as the Peltier effect. Heat is given out or absorbed depending on the pairs of conductors and the direction of the current flow. The quantity of heat  $Q$  given out or absorbed is related to the current  $I$  in the following equation;

$$Q = \Pi_{ab} \cdot I \quad (J) \quad (6.)$$

Where  $\Pi_{ab}$  is the Peltier coefficient, a property that depends on the pair of materials A and B of the junction and also on the junction temperature. The Peltier effect has applications in temperature regulating processes such as refrigeration.

### 3.1.3 Thomson effect:

Thomson effect was observed in 1851 by Lord Kelvin. It describes the heating or cooling of a current-carrying conductor with a temperature gradient, it is the link



between Peltier and Seebeck effect. Thomson observed that when a current is passed through a wire of single homogeneous material, along which a temperature difference exists, heat must be exchanged with the surrounding (depending on the direction of current and material), so that the original temperature gradient may be maintained along the wire.

### **3.2 Thermoelectric generators (TEG) modules :**

A simple thermocouple is an electric generator if there is a temperature gradient across its junctions. The potentials of thermoelectricity for electricity generation were not fully realized until the mid-20<sup>th</sup> century when semiconductor technology became prominent. A TEG module consists of a series of these thermocouples electrically connected in series and thermally connected in parallel. In the early 1960s, General Electric Company Limited patented and commercialized a module composed of semiconductor thermocouples of bismuth telluride in flat bulk architecture[28]. There are different architectures of these thermoelectric modules designed to suit the application it is used, examples of common architecture are the flat bulk architecture, cylindrical bulk architecture, etc[29]. TEGs are also categorized as heat engines but unlike conventional heat engines, TEGs have no mechanical moving parts and are completely silent, they are also reliable as they don't require regular maintenance, they are lightweight, and can be easily scaled to fit large power applications. Though they have lower efficiency compared to conventional heat engines, their cost and ease of application make them competitive for smaller power applications where there is a tradeoff between efficiency, cost, and reliability such as remote sensors, etc[29]. The thermoelectric generator module will generate electricity when there is a temperature gradient ( Seebeck effect ), and in the reversed process when a current is supplied to it, the TEG module will provide cooling or heating. The figure below depicts the scheme of a single thermocouple making up the TEG module.

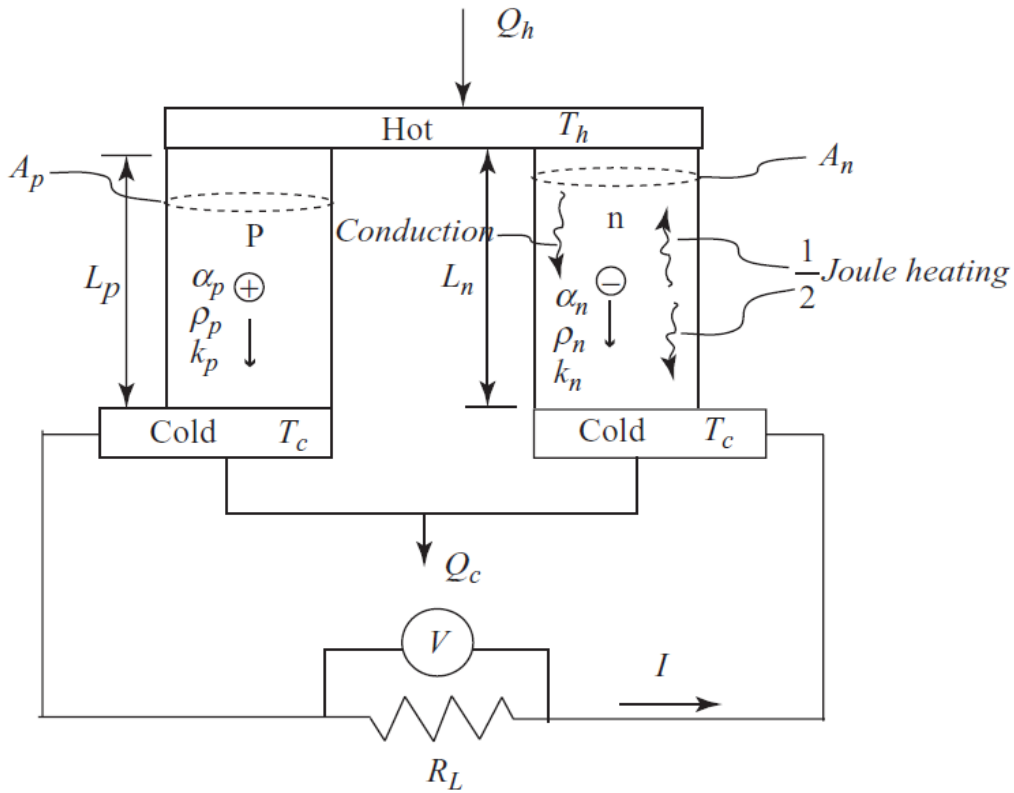

Figure 3.2: A single thermocouple in a thermoelectric module illustrating power generation, the P and N are symbols for p-type and n-type semiconductors respectively,  $T_h$  and  $T_c$  are the hot and cold temperatures respectively,  $L_n = L_p$  is the length of the thermoelements,  $A_n = A_p$  is the cross-sectional area,  $\alpha$  – Seebeck coefficient,  $\rho$  – electric resistivity,  $k$  – thermal conductivity,  $I$  is current.

A typical thermoelectric generator (TEG) module consists of between 10s and 100s thermoelectric semiconductors of type n and type p, electrically connected in series and thermally in parallel, and interposed between two ceramic layers. These ceramic layers act as electric insulators but they also reduce the thermal exchange between the heat source and the thermoelectric module. The figure below depicts the flat bulk architecture, the most widely used and marketed.

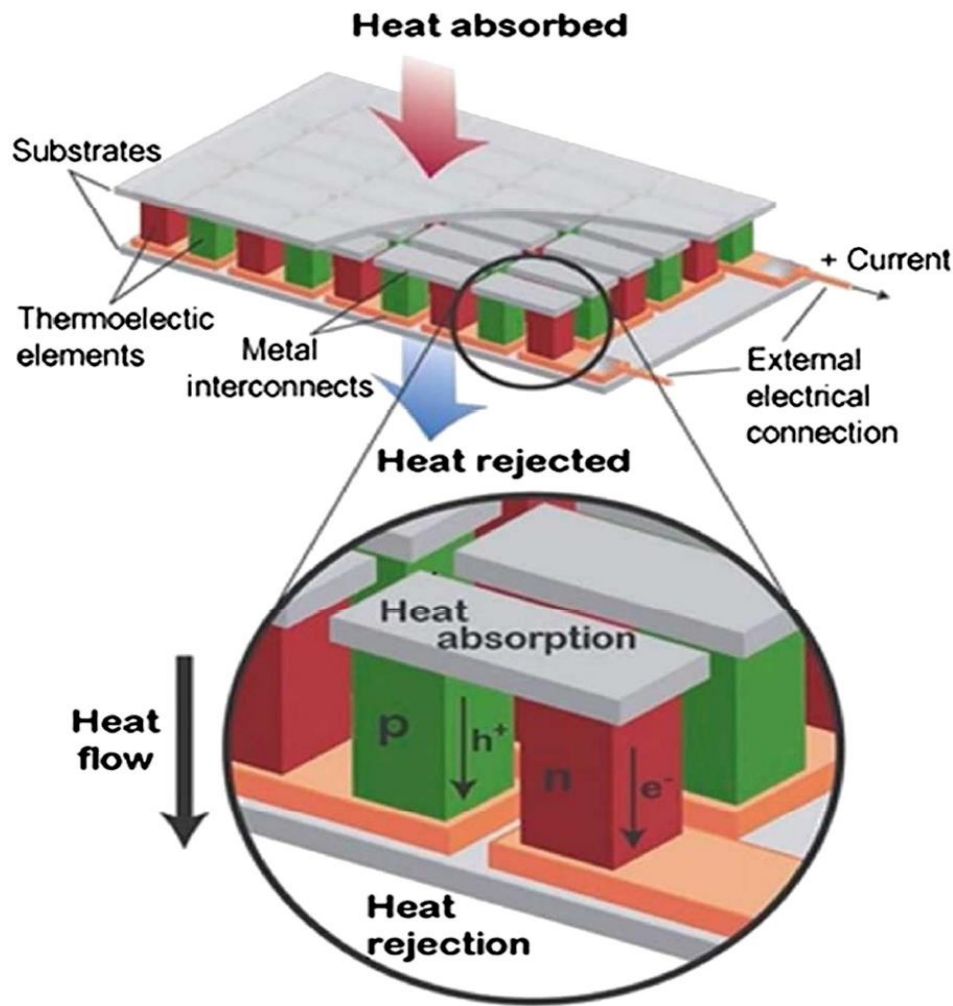

Figure 3.3: Flat bulk architecture of a TEG module[30].

### 3.3 The output power of a thermoelectric generator:

A thermoelectric generator converts heat  $Q$ , into electrical power  $P$  with efficiency  $\eta$ . The relationship between the quantity of heat and power is given in the equation below;

$$P = \eta \cdot Q \quad [W] \quad (7.)$$

The efficiency of a thermoelectric generator depends heavily on the temperature difference  $\Delta T$  between the hot side and the cold side of the module. The thermoelectric generator just like any other heat engine cannot have an efficiency greater than the Carnot's efficiency. The efficiency of a thermoelectric generator is defined as follows;

$$\eta_{TEG} = \frac{T_{hot} - T_{cold}}{T_{hot}} \cdot \frac{\sqrt{1 + ZT} - 1}{\sqrt{1 + ZT} + \frac{T_{hot}}{T_{cold}}} \quad (8)$$

Where  $\eta_{TEG}$  is the efficiency of the TEG module and ZT is the dimensionless figure-of-merit which was first derived by Edmund Altenkirch in 1911. The first part of the equation  $\frac{T_{hot}-T_{cold}}{T_{hot}} = \eta_c$ , where  $\eta_c$  is the Carnot efficiency. From the above equation, it can be deduced that the efficiency of the TEG is directly proportional to the difference in temperature between the hot side and cold side of the TEG module. The figure of merit ZT, which is the property of the material used in making the TEG module is defined as follows;

$$ZT = \frac{\sigma S^2 T}{k} \quad (9)$$

Where T is the average temperature, S is the Seebeck coefficient, k is the thermal conductivity and  $\sigma$  is the electric conductivity. The above equations show that to maximize the ZT of a material, the following criteria must be met; low thermal conductivity to maintain a considerable temperature difference between the two ends of the material, high electrical conductivity, and High Seebeck coefficient. Unfortunately, these conditions are difficult to achieve, as the defined quantities are dependent on each other[27][31]. The dimensionless thermoelectric figure-of-merit ZT is used to characterize the performance of a thermoelectric material. The higher the ZT of a material, the better the TEG module that is made from it.

### 3.4 Components of a thermoelectric energy harvesting system:

A thermoelectric energy harvesting system consists of the following parts; a thermal source, a thermal transducer ( TEG module), a DC-DC converter, and a load.

1. Heat sources, for example, can be waste heat from industrial activities, cooling towers, solar thermal sources, etc.
2. thermal transducer ( TEG module); if a temperature gradient is maintained between the hot and cold sides of the device an external load can be powered.
3. The cold source is the heat transfer system containing heat exchangers (heat sinks, etc), this enhances heat dissipation from the TEG. A heat sink is

a device used to effectively absorb and dissipates heat (thermal energy) to the surroundings (air) using extended surfaces such as fins and spines. Heat sinks are used in applications where efficient heat dissipation is required; major examples include heat engines, cooling electronic devices, etc. The most common design of a heat sink is a metal device with many cooling fins, which is known as a fin array. heatsinks can be used to obtain a big temperature difference across the TEG. A good heat sink will maintain a good temperature gradient across the TEG module. For further reading about heat sink designs, this [32] literature is highly recommended.

4. DC-DC converters (such as boost converters) are power management circuits designed for voltage conversion (to convert a DC source from one voltage level to another voltage level). Since the output of a TEG is usually low or not constant for a required application, a dc-dc converter circuit is always employed in such applications to produce a constant output voltage.
5. Load, a load can be a device that stores the output energy such as rechargeable batteries, capacitors, etc, or a device that consumes the energy directly.

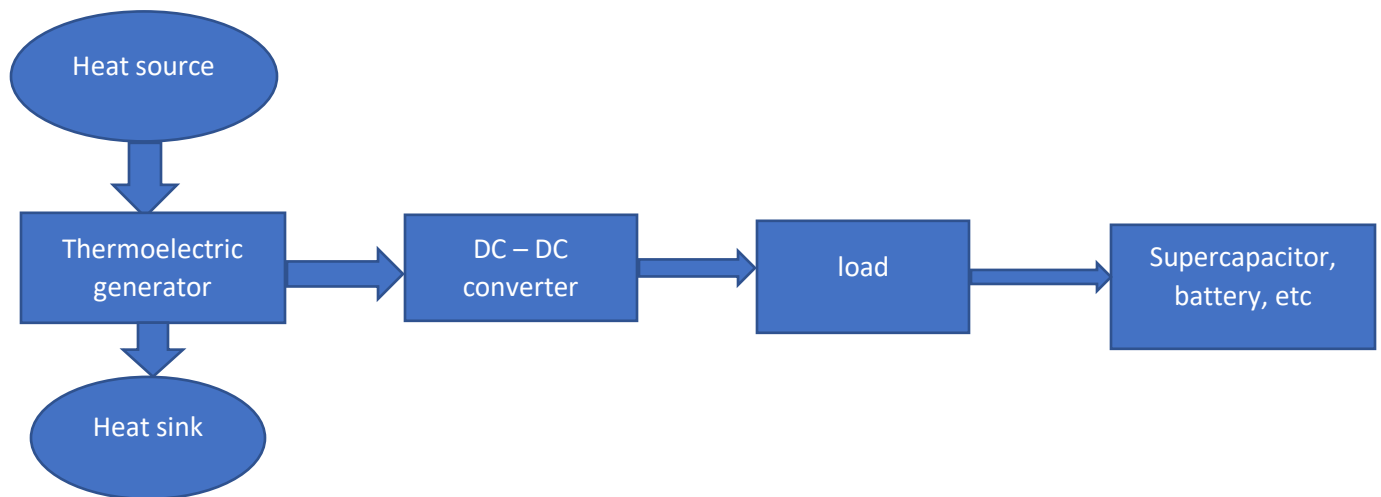

Figure 3.4: A schematic of a simple thermoelectric harvesting system

The overall efficiency of the thermoelectric energy harvesting system is defined as the ratio of the electrical energy output (used or stored) to the total energy input. This can be improved by using a TEG module made from a material with good figure-of-merit or by having a large temperature difference between the hot side and the cold side of the TEG module.

## Chapter 4: Experiments, results, and analysis:

### 4.1 The need and choice of heat sink for the cold side:

The output power of a TEG is dependent on the material figure-of-merit, which is fixed for a particular TEG, and the temperature gradient between the hot and the cold side of the TEG which can be varied. Air has a very low thermal conductivity, hence relying on the natural convection of air to cool down the cold side of TEG, will not result in a large temperature gradient to give out a sensible output in the best-case scenario. Therefore a passive mechanical heat sink is required and also to have good thermal contact between the TEG module and the heatsink a thermal interface material (thermal paste) is required. For a normal application that involves the deployment of heat sinks the following conditions have to be considered;

1. The quantity and rate of heat dissipation
2. Maximum allowable Junction temperature
3. Ambient temperature of the surrounding fluid in this case air.
4. Thermal Resistance of the device junction-to-case
5. The thermal resistance of the thermal interface material in this case thermal paste
6. Thermal resistivity, thickness, and contact area of the heat sink
7. Natural or forced convection for cooling the heat sink

The above conditions were difficult to assess, as the quantity of heat loss from the cup containing hot water cannot be determined as heat lost from the cup is in all directions and not only through the junction. Hence the calculation for the exact property of a suitable heat was not made rather, three Wakefield-Vette spirled[33] heat sinks made of aluminum, with different lengths, diameters, and thermal properties but with the same cylindrical shape and design were obtained. The properties of these heatsinks are given in the table below;

Heatsink	Height [mm]	Diameter [mm]	Thermal resistance [°C/W]	Dissipated Power [W]
SpirLed-11080	80	110	0.9	57
SpirLed-9680	80	96	0.9	49.2
SpirLed- 8540	40	85	1.9	26

Table: table comparing basic data of heatsinks[34][33].

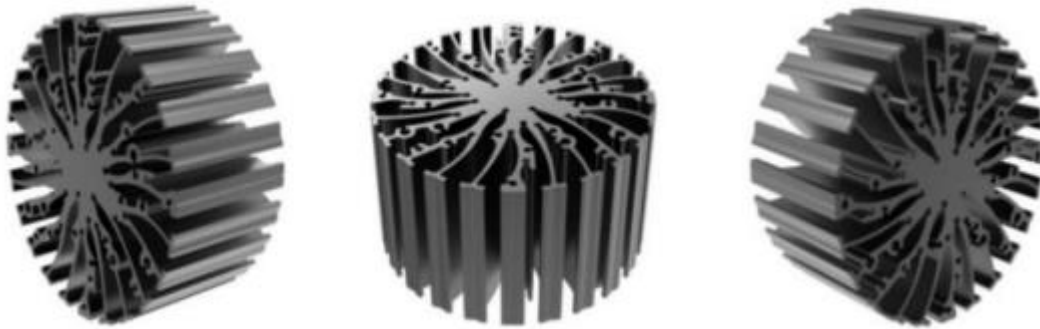

Figure 4.1: the shape of heatsinks[34]

To pick a suitable heatsink for the project I compared the performance of these three heatsinks, by directly placing a cup of hot water boiled to 100 °C on them, to maintain good thermal contact between the cup and the heat sink I used a thermal paste, and I recorded the images with the thermal camera after 5 and 10 minutes to assess the rise of temperature of the heatsink, which ideally should be at 23 °C ( room temperature), and the pictures obtained are given in the following figures below;



Figure 4.2: Spirled Heatsink 8540 after 5 mins

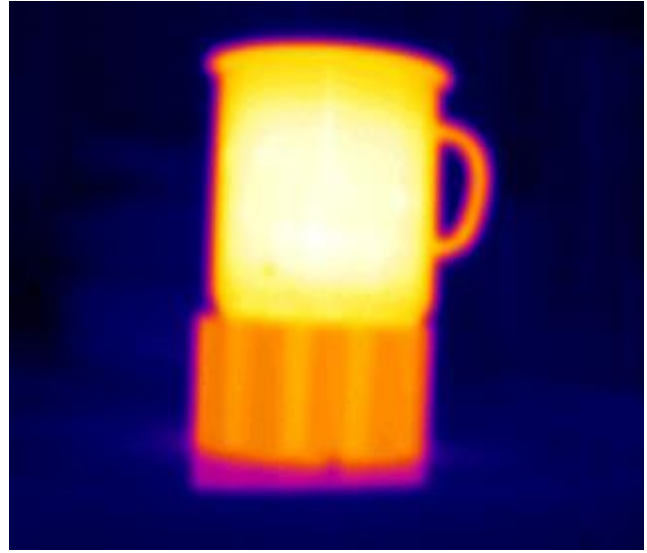

Figure 4.3: Spirled Heatsink 8540 after 10 mins

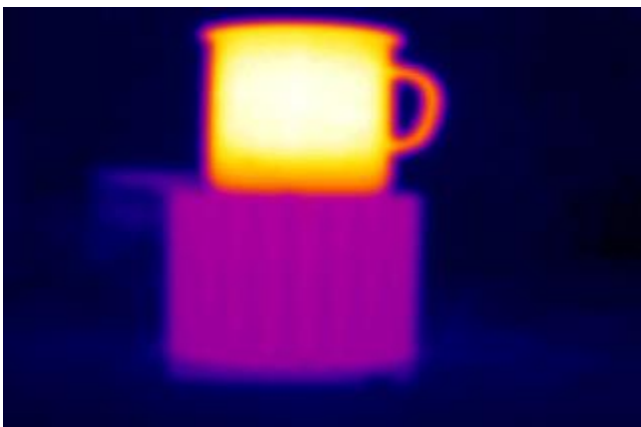

Figure 4.4: Spirled heatsink 11080 after 5 minutes

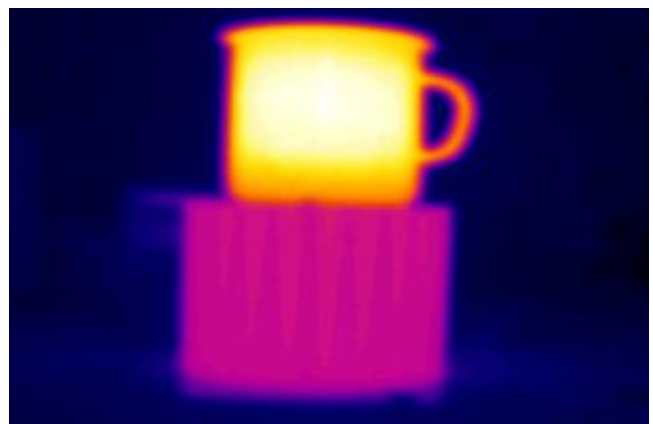

Figure 4.5: Spirled heatsink 11080 after 10 minutes

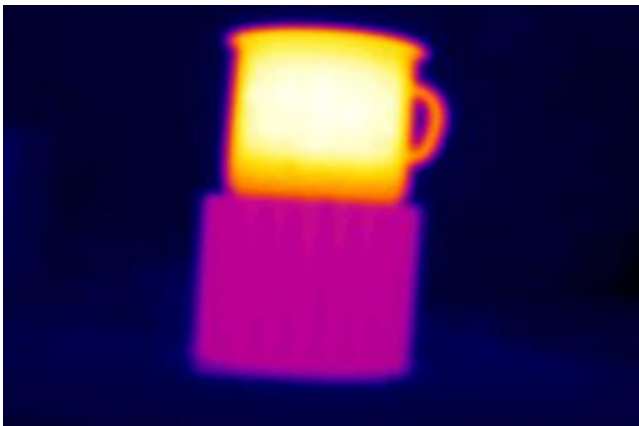

Figure 4.6: Spirled heatsink 9680 after 5 minutes

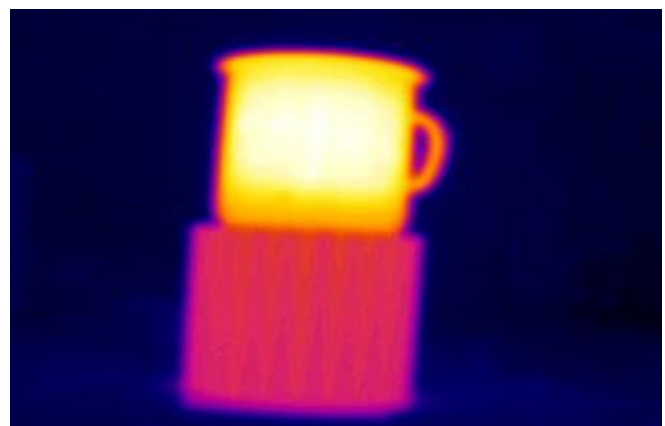

Figure 4.7: Spirled heatsink 9680 after 10 minutes



To obtain a higher output power a high-temperature gradient between the cold side and hot side of the Peltier module is required. I measured the temperature gradient for each of the heat sinks so that I can choose the heat sink that will provide me with the highest temperature gradient hence higher power output. I measured the temperature of the bottom of the cup and the temperature of the heat sink using a k-type thermocouple thermometer. The following graphs were obtained;

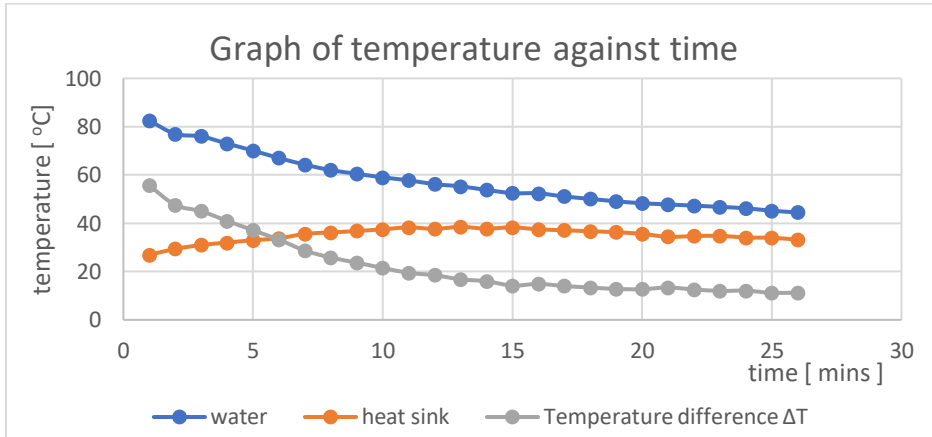

Figure 4.8: graph of temperature against time for spiraled heatsink 11080

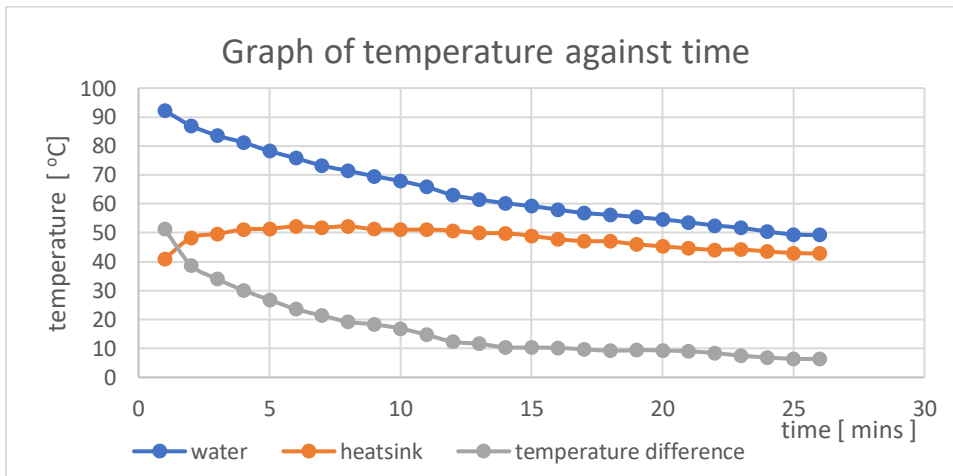

Figure 4.9: graph of temperature against time for spiraled heatsink 8640

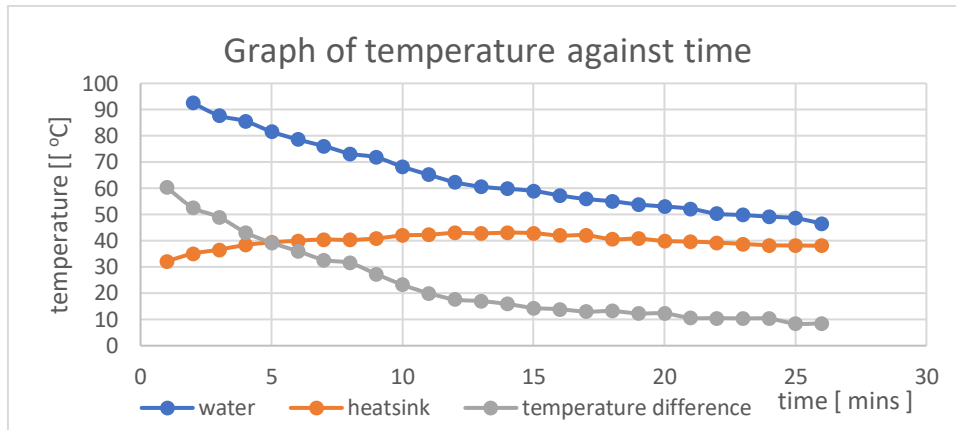

Figure 4.10: graph of temperature against time for spirled heatsink 9680

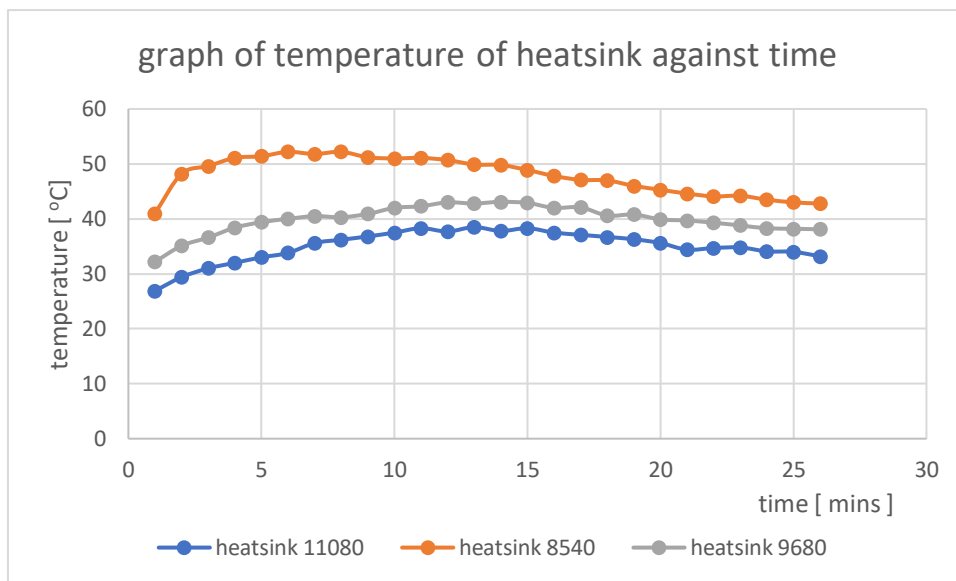

Figure 4.11: Graph comparing the temperature of each sink against time.

From the above graphs, it can be seen that after a long time the spirled heatsink 11080 maintained the lowest temperature hence the higher the temperature gradient that can be obtained with this heatsink. Based on these results, I chose heatsink 11080 as a suitable heat sink for my project.

#### 4.2 Characterization of the voltage vs. $\Delta T$ curve of the Peltier cell.

I carried out an open circuit test on the Peltier module to know if the output voltage is large enough to be stepped up for useful applications, as the DC-DC converter requires a minimum input voltage to produce a sensible output voltage. To know the output voltage of the Peltier module I performed an open circuit test where the circuit was not loaded. The test involved supplying a temperature

gradient and measuring the temperature of the cold side and hot side and also measuring the output voltage. The experimental setup consists of the following;

1. A stainless steel plated cup that acts as a thermal mass accumulator for the hot side of the TEG.
2. An aluminum wedge; to avoid direct contact of the TEG module with the cup and the heatsink which can cause mechanical damage to the module which may arise from constant placing and removal of the cup between experiments, the TEG module is sandwiched between this aluminum wedge.
3. Digital thermometers with k-type thermocouples to measure the temperature of the hot side and the cold side.
4. Proskit MT-1860 digital multimeter for the measurement of the output voltage.
5. Peltier cell (TEG module); the TEG module used in the experiment is the Wakefield-Vette TEC 40-33-127.



Figure 4.12: Wakefield-Vette Peltier module[35]

And the figure below depicts the experimental setup;

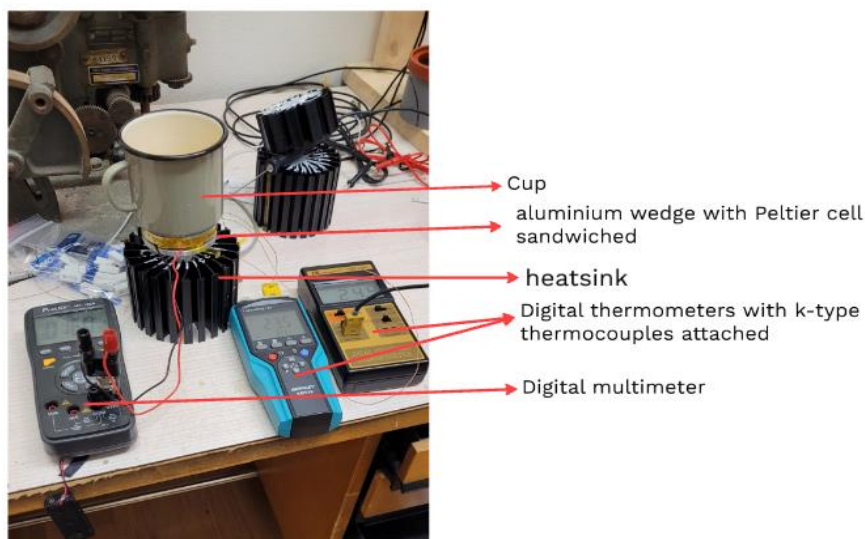

Figure 4.13: experimental setup for voltage characterization of the Peltier cell.

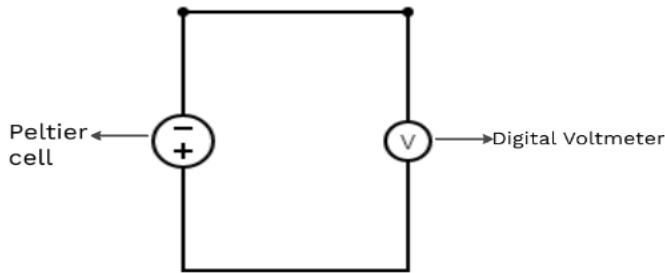

Figure 4.14: Scheme of the experimental setup

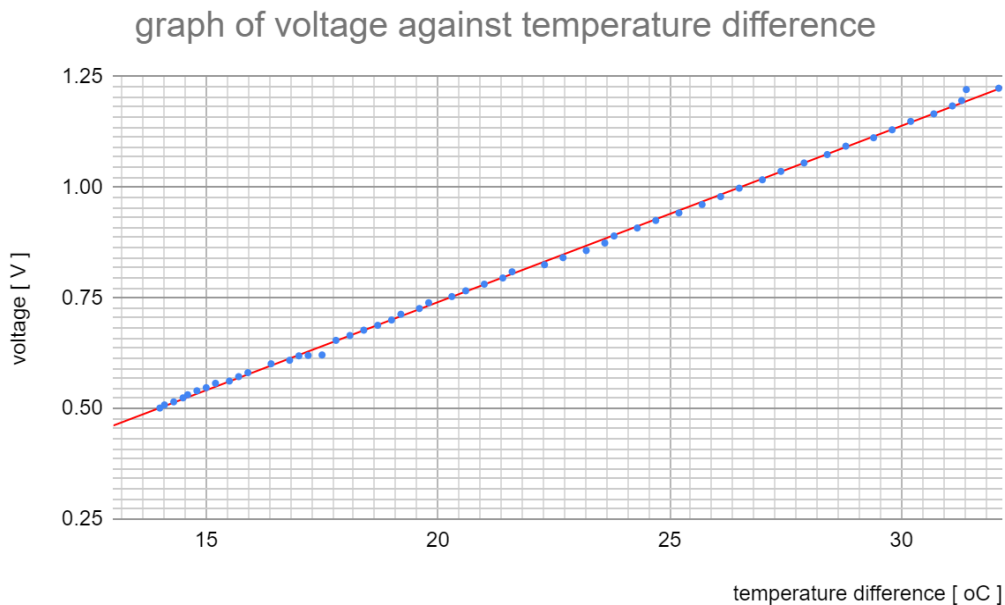

Figure 4.15: graph of voltage against temperature difference

From the graph above the direct relationship between the output voltage of the Peltier and the temperature difference can be deduced, it can be seen that as the temperature gradient increases the output voltage increases linearly, and the minimum open voltage I can get for a temperature difference of about 10 °C is about 0.5 V which is suitable for the DC-DC converter that requires a minimum of 0.3V to produce a sensible output.

### 4.3 Power Output of the Peltier cell

To determine the power output and the maximum power output I can get from the Peltier module I loaded the module with different ceramic resistors with small resistance values and using a digital multimeter I measured the output voltages

across the resistor for a specific a period while the output voltage is not lower than 0.3V as 0.3V is the minimum input voltage for the DC-DC converter. From these values I calculated the output power using the following equation;

$$P = V^2/R \quad [ W ] \quad (10)$$

The Figure below shows a simple scheme of the experimental setup with the Peltier cell modeled as a voltage source and with the load resistance in this case equal to 1 Ω;

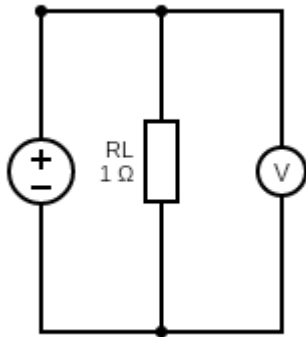

Figure 4.16: Scheme of the experimental setup for load resistance  $R_L = 1 \Omega$

I performed a similar experiment with different resistor values, in between the experiments I ensured equal initial temperature of the heatsink and the cup by cooling them to room temperature with cold water. The resistor values I used are tabulated below;

Load Resistor	Value [ Ω ]
R1	1
R2	2.2
R3	4.7
R4	10
R5	20

Table 2: table of load resistance and their values

The values obtained for each resistor value were tabulated and the graphs obtained from this are given below;

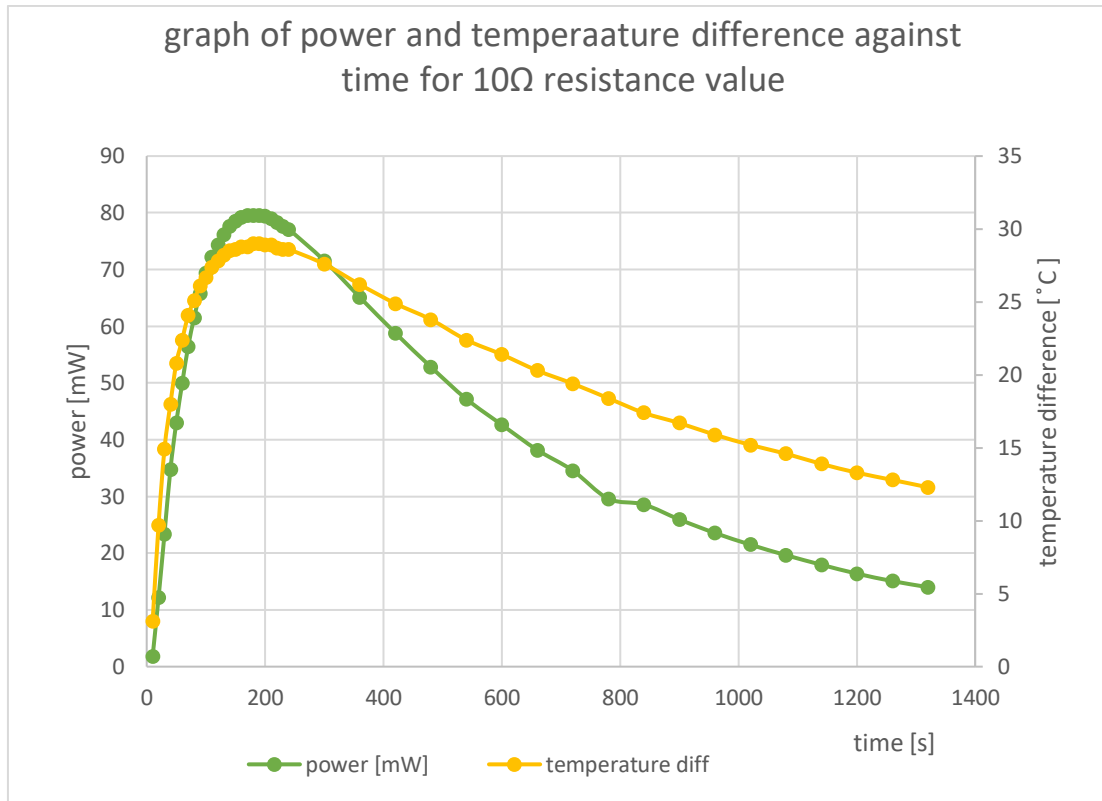

Figure 4.16: graph of output power and temperature difference for resistor 10Ω

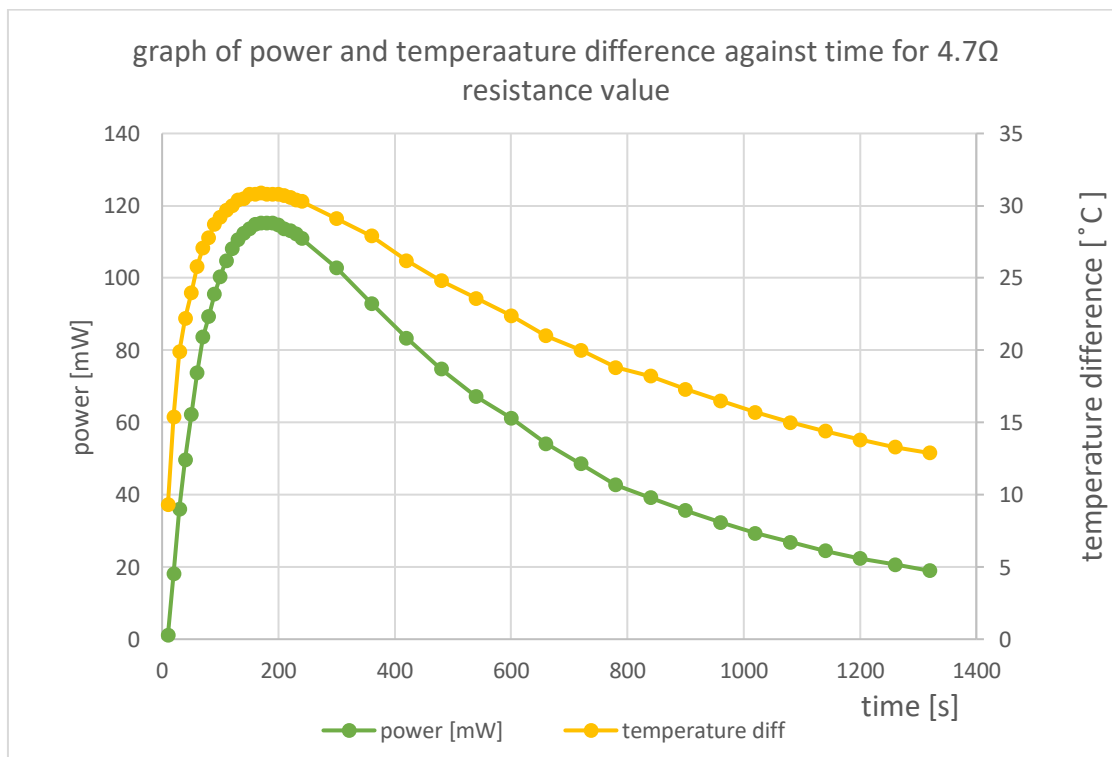

Figure 4.17: graph of output power and temperature difference for resistor 4.7Ω

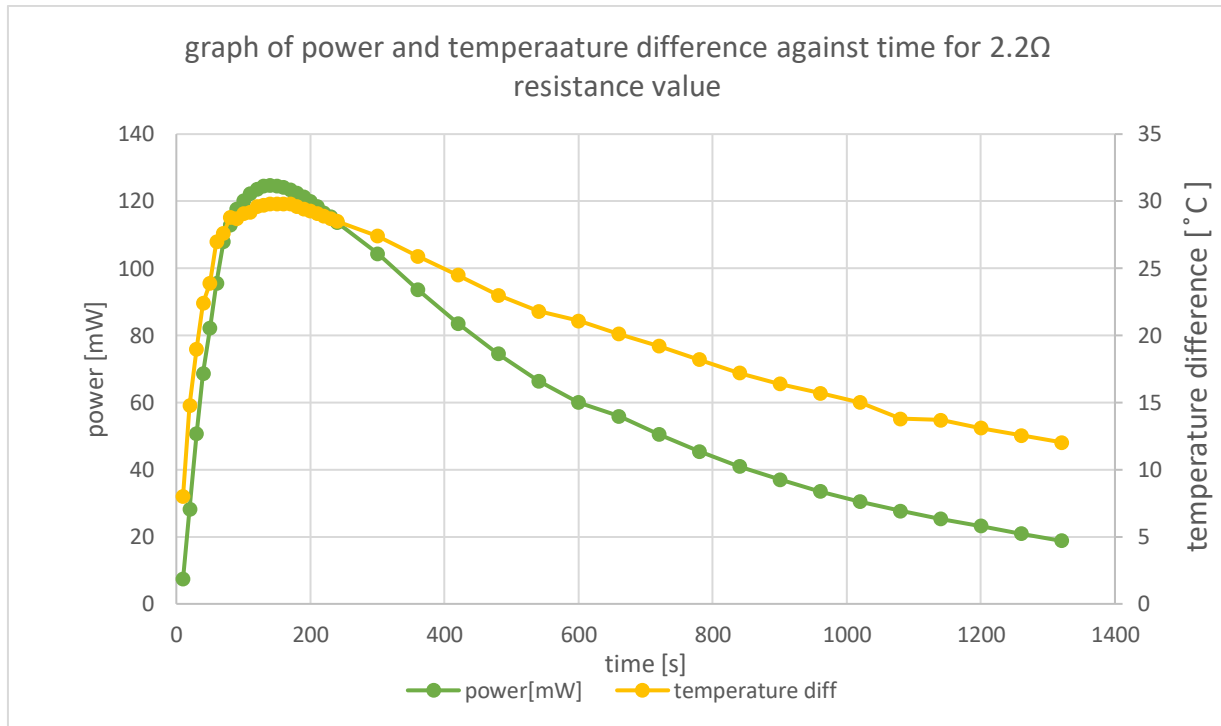

Figure 4.18: graph of output power and temperature difference for resistor 2.2Ω

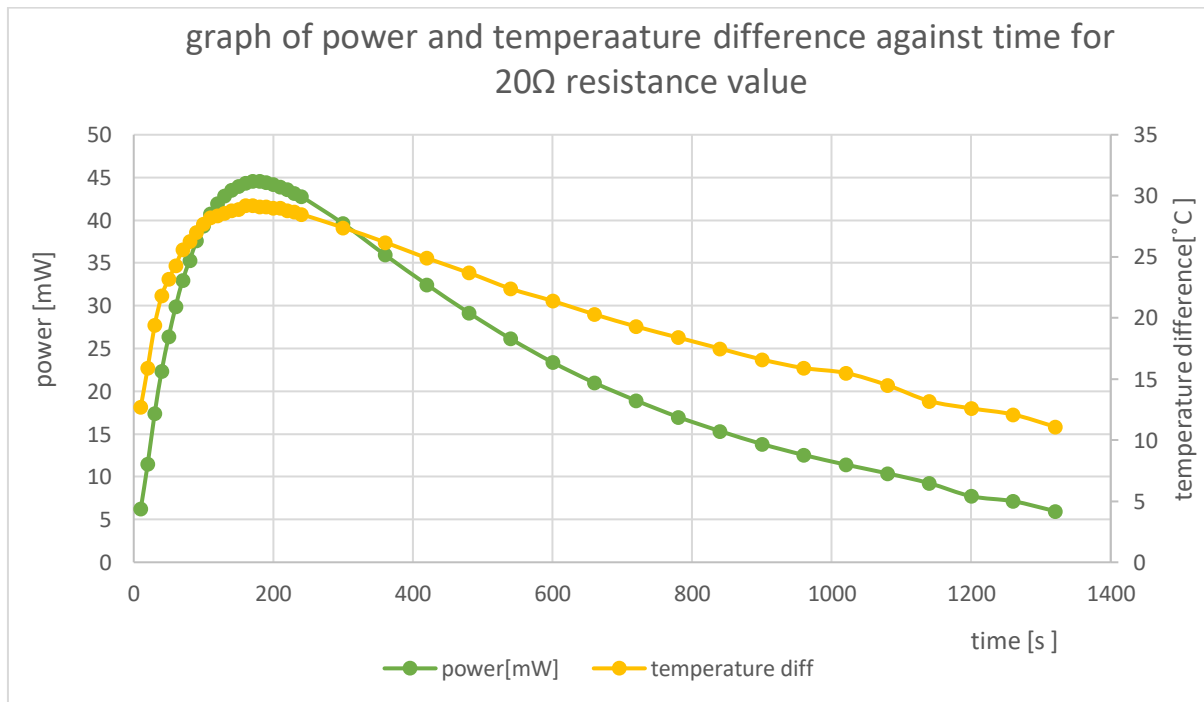

Figure 4.19: graph of output power and temperature difference for resistor 20Ω

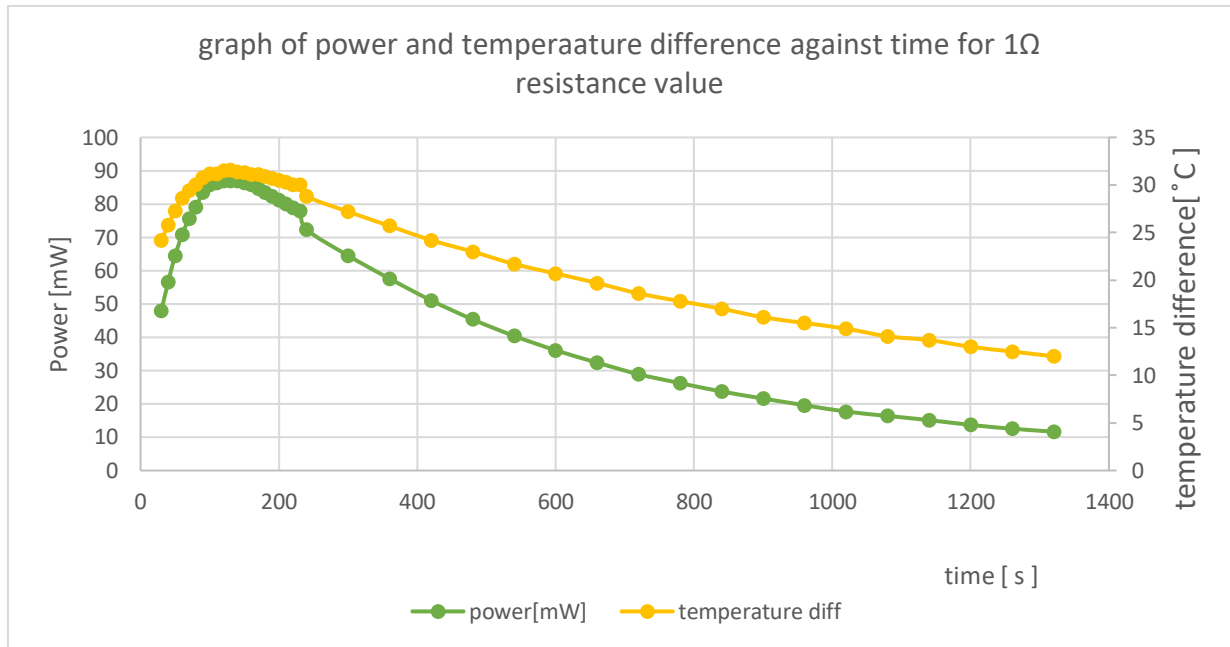

Figure 4.20: graph of output power and temperature difference for resistor 1Ω

From the graphs of power against time, I calculated the area under each of the curves to obtain the energy output of the Peltier module for each resistance value of the loading resistor and this is depicted in the figure below;

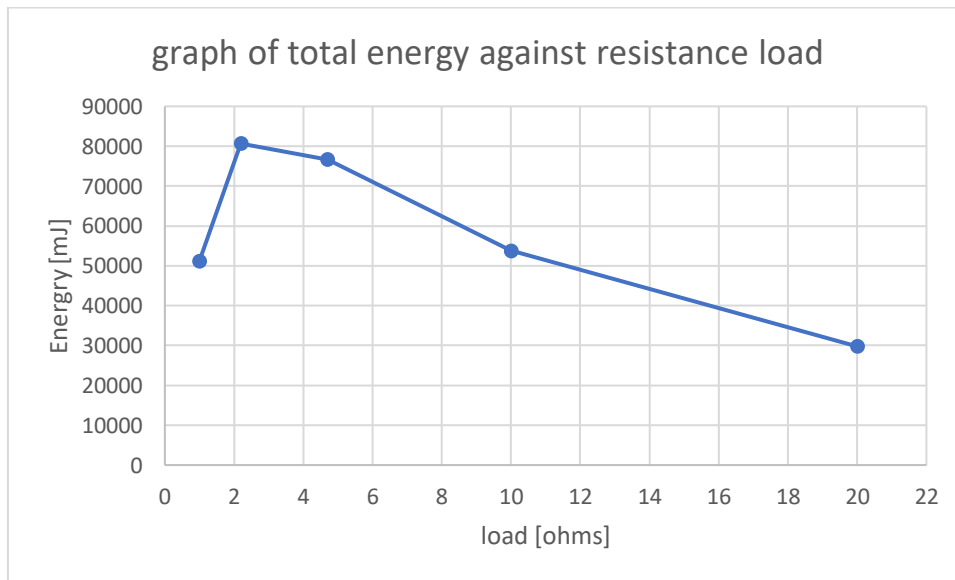

Figure 4.21: Graph of output energy against resistance values

From the above figure, it can be seen that the largest output energy is when the Peltier device is loaded with a 2.2 Ω resistor.



#### 4.4 Charging a Mobile Phone:

My mobile phone battery has a power rating of 4500mAh and a minimum of 5V is required to charge the battery, though there is a maximum current rating there is no minimum current required. If the current is too low it will take a very long time to charge. For example, if the input current is 20 mA the total time required to fully charge the battery will be approximately 9 days.

$$\text{charge time in hours} = \frac{\text{battery capacity in Amp hours}}{\text{charging current Amps}} \quad (10)$$

Inputting 20mA for the charging current with 4500mAh as the battery capacity into the equation above you will obtain 9days of charging time.

To have a 5V input, I have to step up the small voltage produced by the Peltier cell to 5V and to do this I used a DC-DC boost converter capable of outputting 5V. The DC-DC boost converter I used is the texas instrument TPS61200 evaluation module 179. This module is capable of taking an input voltage as low as 0.3V and stepping it up to 5.5V[36] which is suitable for my application.

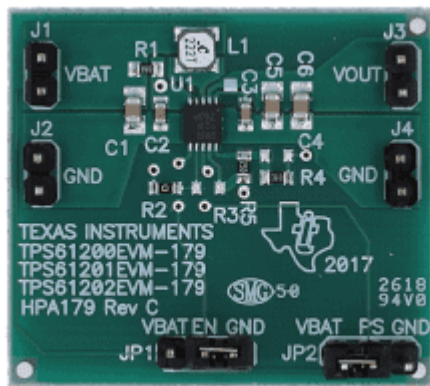

Figure 4.22: TPS61200 evaluation module 179 [1]

The datasheet for the DC-DC converter did not provide me with enough information about the efficiency of the converter. So I experimented with different loads at the output of the DC-DC converter and calculated the efficiency for each load, I also attempted to charge my phone with the output voltage. For this, I used the following pieces of equipment and procedures and the setup is given in figure 4.23; I measured the resistance of my phone by connecting the charging point using a USB and connecting it to a Hewlett Packard 34401A digital

multimeter, using the 4-wire method I obtained a resistance value of approximately 600  $\Omega$ .

Load resistors RL	Resistor values [ $\Omega$ ]
R1	400
R2	500
Mobile phone	600
R3	600
R4	700
R5	800
R6	900

Table 3: table of load resistors with their values

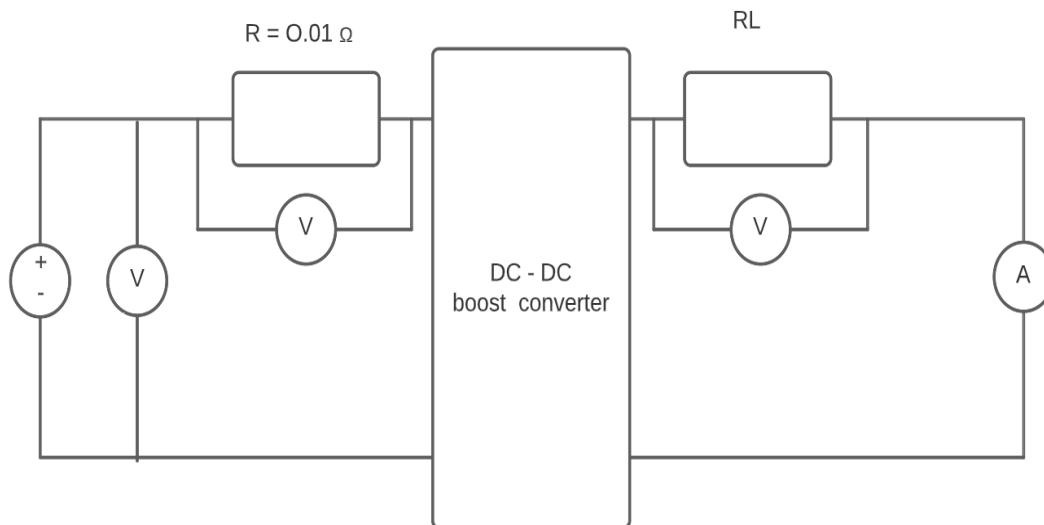

Figure 4.23; setup for DC-DC conversion with TPS61200 evaluation module 179

1. I modeled the Peltier cell as a voltage source and I measured the output voltage of the Peltier cell using Keithley 2001 Multimeter
2. I used a 0.01  $\Omega$  resistor connected in series with the DC-DC converter and I measured the voltage across the 0.01  $\Omega$  using Agilent 34401A digital multimeter from this value I calculated the input current. I subtracted the voltage across the 0.01  $\Omega$  from the output voltage from this value I obtained the voltage at the input of the DC-DC converter, and from the input voltage of the DC-DC converter and the input current I calculated the input power to the DC-DC converter.

3. I connected the output of the DC-DC converter to a load resistor  $R_L$ , and I measured the voltage across the load resistor using ProsKit MT-1860 digital multimeter and the current through the resistor with Hewlett Packard 34401A digital multimeter, From these values, I calculated the output power of the DC-DC converter for each load resistor.
4. For each load, I calculated the efficiency as follows;

$$efficiency = \frac{output\ power}{input\ power} \cdot \% \quad (11)$$

From the values of the efficiency, I tabulated the maximum efficiency for each load resistance below along with input and output power, voltage, and current respectively, the values also correspond to the maximum output power obtained with each load;

Load resistors	Input voltage [V]	Input current [mA]	Output Voltage [V]	Output Current [mA]	Input power [mW]	Output Power [mW]	Maximum Efficiency [%]
R1	0.3308	335.8	3.506	8.764	111.096	30.726	27.66
R2	0.3183	299.3	3.755	7.989	95.269	29.998	31.49
R3	0.3479	314.0	4.637	7.714	109.228	35.769	32.75
Mobile phone	0.3263	298.8	4.349	7.218	97.502	31.391	32.20
R4	0.8326	81.6	5.002	7.142	67.947	35.724	52.58
R5	0.8391	71.3	5.008	6.258	59.827	31.340	52.38
R6	0.8569	62.5	5.013	5.569	53.560	27.917	52.12

Table 4: table depicting maximum efficiency obtained for different load resistors

From the last experiment, I observed that the efficiency of the DC-DC depends strongly on the input voltage, as can be seen from the table above, and the output voltage when I loaded it with the phone was less than 5V, hence I was not able to charge the mobile phone. I performed a similar experiment with a similar setup, by replacing the Peltier cell with a voltage generator to supply the DC-DC converter and loading the converter with a mobile phone. I measured the output voltage and the output current with ProsKit MT-1860 digital multimeter and Hewlett Packard 34401A digital multimeter respectively. The experimental scheme is given below;

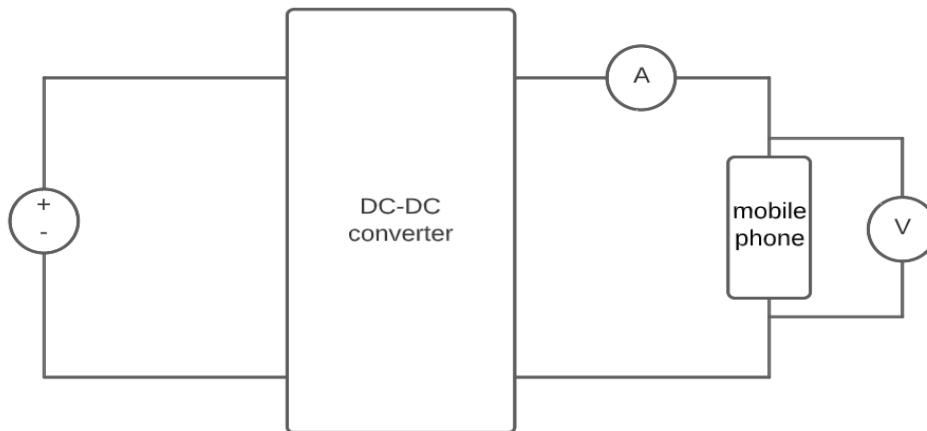

Figure 4.25; experimental scheme with a voltage generator as a voltage source

And the results I obtained are tabulated below;

Input voltage [V]	Input current [mA]	output voltage [V]	Output current [mA]	Input power [mW]	Output power [mW]	efficiency [%]
0.327	294.2	4.34	7.06	96.203	30.640	31.85
0.404	480.1	4.39	13.20	193.960	57.948	29.88
0.504	737.0	4.43	21.00	371.448	93.030	25.06
0.607	993.3	4.48	28.20	602.933	126.336	20.95
0.705	1215.0	4.51	34.60	856.575	156.046	18.22
0.803	1422.0	4.55	41.00	1141.866	186.550	16.34
1.04	850.2	4.91	101.50	884.208	498.365	56.36
1.22	700.1	5.00	115.60	854.122	578.000	67.67
1.5	496.4	5.00	116.10	744.600	580.500	77.96
1.81	386.0	5.00	116.50	698.660	582.500	83.37

Table 5: table depicting the relationship between efficiency and input voltage and current for mobile phone as a load

I was able to charge the phone at an output voltage of 5V which corresponds to an input voltage of 1.2V, and an input current of 700mA, and as the voltage values increase the efficiency of the converter also increases. Because of this, I opted to charge a battery with the output of the Peltier cell, then use the battery to charge up the phone. I made use of the texas instrument bq25570-evaluation module, which is capable of harvesting from as low as 100mV input voltage and stepping it up to 4.2V [37], and storing this energy in a rechargeable battery for later use. This module also implements maximum power point tracking algorithms which cause



Figure 4.26: bq25570 evaluation module [38]

the thermoelectric module to operate at the maximum powerpoint. I got two Eneloop Ni-MH batteries with a power rating of 1.2V and 1900mAh initially, the two batteries came fully charge so I have to discharge them, and with that power rating, it will take too long to discharge and it is also bulky so I opted for two low capacity and a smaller size Ni-MH batteries with a capacity of 1.2V and 300mAh. I discharged the two smaller batteries to 30% of their original rating using a 12-ohm resistor to drain them. Then I charge them with the Peltier cell, With the bq25570 evaluation module as a booster. The Figure below shows the scheme of the experimental setup with the bq25570 evaluation module.

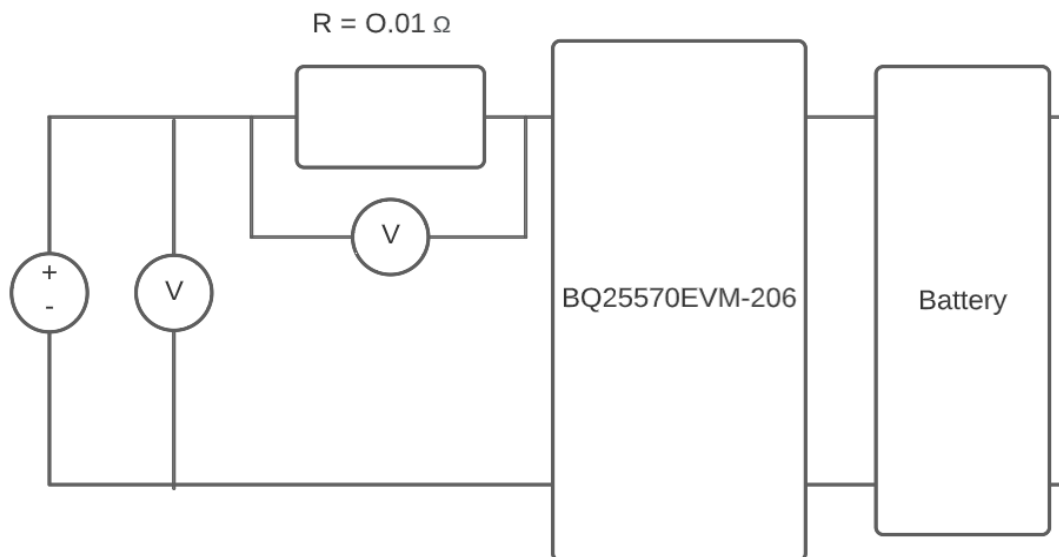

Figure 4.27: use of bq25570 evaluation module to charge up a battery.

I measured the output current from the bq25570 with a digital multimeter and the value I got was 30mA, using equation 10, it will take about 10 hours to fully charge up the batteries. I charged the battery for about 30minutes.

In the experimental setup given below; I used the two batteries as a voltage source, having them in series I was able to have 2.4 V at the input of the DC-DC converter (TPS61200 evaluation module), stepping this voltage up with a DC-DC converter (TPS61200 evaluation module) to 5V and using it to charge a mobile phone.

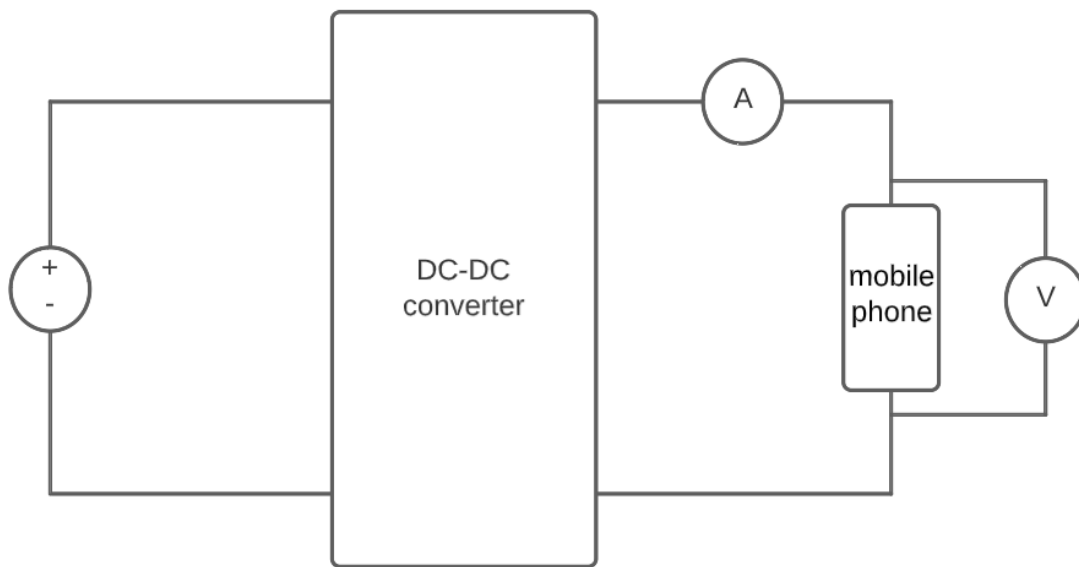

Figure 4.28: Use of battery as a voltage source to charge a mobile phone

The output current I measured was 115mA and the voltage was 5V, with this current it will take approximately 39 hours to fully charge my phone which has a battery capacity rating of 4500mAh.

## **Chapter 5: Conclusions and Possible improvements**

In this thesis, I exploited the feasibilities of thermoelectricity in small-scale electricity generation. The idea of thermoelectricity has been in place for more than a century now, and it is very popular in large waste heat recovery technologies. Although the output current I got was small such that it will take a very long time to fully charge a mobile phone like mine which also requires a minimum input voltage of 5V which in a real-world scenario with improvements in mobile phone charging technologies charging of phone this way may not be fashionable. But using this current to charge up a battery that can be used for various applications and not just mobile phones is something that holds potential in the nearest future. Improvements can be made to the procedures I used and one possible improvement is to have a well thermal insulated energy collector on the hot side that allows heat loss in just one direction (through the Peltier module ) and also by placing the heatsink in cold water while harvesting, this will ensure a large temperature gradient for a long time, which implies larger power output for a long time another possible improvement is to take advantage of the scalability of thermoelectricity by having more modules in series which ensures larger output voltage, and parallel connections which can output larger currents.

## Bibliography and References:

- [1] "TPS61200EVM-179 Evaluation board | TI.com."  
<https://www.ti.com/tool/TPS61200EVM-179?keyMatch=TPS61200EVM-179#tech-docs>  
(accessed May 19, 2022).
- [2] L. (International E. A. Cozzi and T. (International E. A. Gould, "World Energy Outlook 2021," pp. 1–386, 2021, [Online]. Available: [www.iea.org/weo](http://www.iea.org/weo).
- [3] "Global warming and climate change effects: information and facts."  
<https://www.nationalgeographic.com/environment/article/global-warming-effects>  
(accessed Apr. 20, 2022).
- [4] I. E. A. IEA, "Electricity Market Report," *Electr. Mark. Rep.*, no. January, 2022, [Online]. Available: <https://www.iea.org/reports/electricity-market-report-january-2022>.
- [5] "Energy density - Energy Education."  
[https://energyeducation.ca/encyclopedia/Energy\\_density](https://energyeducation.ca/encyclopedia/Energy_density) (accessed Apr. 21, 2022).
- [6] F. Luis and G. Moncayo, *No 主観的健康感を中心とした在宅高齢者における健康関連指標に関する共分散構造分析* Title. .
- [7] D. Halliday, R. Resnick, and G. H. Bowen, *Fundamentals of Physics*, vol. 25, no. 4. 1972.
- [8] P. Glynne-Jones, M. J. Tudor, S. P. Beeby, and N. M. White, "An electromagnetic, vibration-powered generator for intelligent sensor systems," *Sensors Actuators, A Phys.*, vol. 110, no. 1–3, pp. 344–349, 2004, doi: 10.1016/j.sna.2003.09.045.
- [9] C. Covaci and A. Gontean, "Piezoelectric energy harvesting solutions: A review," *Sensors (Switzerland)*, vol. 20, no. 12, pp. 1–37, 2020, doi: 10.3390/s20123512.
- [10] "Wimshurst Machine, Electrostatic Generator - Arbor Scientific."  
<https://www.arborsci.com/products/wimshurst-machine> (accessed May 18, 2022).
- [11] P. Sensorics, Jan Tichý, Jiří Erhart, Erwin Kittinger, Jana Přivratská auth. *Fundamentals of Piezoelectric Sensorics Mechanical, Dielectric, and Thermodynamical Properties of Piezoelectric Materials.pdf*. .
- [12] "Direct and converse piezoelectric effect. | Download Scientific Diagram."  
[https://www.researchgate.net/figure/Direct-and-converse-piezoelectric-effect\\_fig2\\_329228323](https://www.researchgate.net/figure/Direct-and-converse-piezoelectric-effect_fig2_329228323) (accessed May 18, 2022).
- [13] A. R. Laskar, "Piezoelectricity: An Energy Source for Future Railway Stations," *J. Sci. Eng.*, vol. 11, no. March, pp. 1–6, 2017, doi: 10.6084/m9.figshare.12520526.v1.
- [14] S. Priya and D. J. Inman, *Energy harvesting technologies*. 2009.
- [15] B. C. Sekhar *et al.*, "Piezoelectricity and Its Applications," *Multifunct. Ferroelectr. Mater.*, Sep. 2021, doi: 10.5772/INTECHOPEN.96154.



- [16] G. Oliveti, L. Marletta, N. Arcuri, M. De Simone, R. Bruno, and G. Evola, "Solar energy," *Green Energy Technol.*, vol. 0, no. 9783319030739, pp. 159–214, 2014, doi: 10.1007/978-3-319-03074-6\_4.
- [17] "World of Change: Global Temperatures." <https://earthobservatory.nasa.gov/world-of-change/global-temperatures> (accessed May 04, 2022).
- [18] I. B. Fridleifsson, R. Bertani, E. Huenges, J. W. Lund, and A. Ragnarsson, "The possible role and contribution of geothermal energy to the mitigation of climate change," *IPCC Geotherm.*, pp. 59–80, 2008.
- [19] I. B. Fridleifsson, R. Bertani, and E. Huenges, "The possible role and contribution of geothermal energy to the mitigation of climate change," *IPCC Scoping Meet. Renew. Energy Sources*, no. January, pp. 59–80, 2008, [Online]. Available: <http://scholar.google.com/scholar?hl=en&btnG=Search&q=intitle:The+possible+role+and+contribution+of+geothermal+energy+to+the+mitigation+of+climate+change#0>.
- [20] K. Li *et al.*, "Thermoelectric power generator: Field test at Bottle Rock geothermal power plant," *J. Power Sources*, vol. 485, p. 229266, Feb. 2021, doi: 10.1016/J.JPOWSOUR.2020.229266.
- [21] "ocean thermal energy conversion | technology | Britannica." <https://www.britannica.com/technology/ocean-thermal-energy-conversion> (accessed May 04, 2022).
- [22] K.-I. Uemura, "Uemura History of thermoelectricity development in," *Japan J. Thermoelectr.*, vol. 3, 2002.
- [23] "• Tea consumption wby country | Statista." <https://www.statista.com/statistics/940102/global-tea-consumption/> (accessed May 05, 2022).
- [24] "Battery Comparison of Energy Density - Cylindrical and Prismatic Cells." <https://www.epectec.com/batteries/cell-comparison.html> (accessed May 18, 2022).
- [25] E. Hossain, H. M. R. Faruque, M. S. H. Sunny, N. Mohammad, and N. Nawar, "A comprehensive review on energy storage systems: Types, comparison, current scenario, applications, barriers, and potential solutions, policies, and future prospects," *Energies*, vol. 13, no. 14, pp. 1–127, 2020, doi: 10.3390/en13143651.
- [26] "Energy transfer in the atmosphere « KaiserScience." <https://kaiserscience.wordpress.com/earth-science/atmosphere/energy-transfer-in-the-atmosphere/> (accessed May 18, 2022).
- [27] M. Isabirye, D. V. . Raju, M. Kitutu, V. Yemeline, J. Deckers, and J. Poesen Additional, "We are IntechOpen , the world ' s leading publisher of Open Access books Built by scientists , for scientists TOP 1 %," *Intech*, p. 13, 2012, [Online]. Available: <http://dx.doi.org/10.1039/C7RA00172J%0Ahttps://www.intechopen.com/books/advanced-biometric-technologies/liveness-detection-in->

biometrics%0Ahttp://dx.doi.org/10.1016/j.colsurfa.2011.12.014.

- [28] W. Tor and C. Yzom, "MANUFACTURE OF THERMOELECTRIC DEVICES so QQ Li," 1961.
- [29] R. He, G. Schierning, and K. Nielsch, "Thermoelectric Devices: A Review of Devices, Architectures, and Contact Optimization," *Adv. Mater. Technol.*, vol. 3, no. 4, 2018, doi: 10.1002/admt.201700256.
- [30] S. Thermoelectric Generators, "The Electrochemical Society Interface FEATURED ARTICLES."
- [31] H. J. Goldsmid, *Optimisation and selection of semiconductor thermoelements*, vol. 121. 2016.
- [32] H. S. Lee, *Thermal Design: Heat Sinks, Thermoelectrics, Heat Pipes, Compact Heat Exchangers, and Solar Cells*. 2010.
- [33] "LED Heat Sinks SPIRLED Heat Sink 48mm Diameter."
- [34] "LED Heat Sinks FLOWLED Heat Sink 38mm Diameter Thermal Data FLOWLED-3850."
- [35] "TEC-40-33-127 - Wakefield Thermal - PELTIER MODULE, 72W, 40 x 40 x 3.3mm." <https://cz.farnell.com/wakefield-solutions/tec-40-33-127/peltier-module-72w-40-x-40-x-3/dp/3018641> (accessed May 18, 2022).
- [36] Texas Instrument, "Tsp6120 Low Input Voltage Synchronous Boost Converter With 1.3-a Switches," p. 35, 2007.
- [37] Texas Instruments, "Bq25570 Nano Power Boost Charger and Buck Converter," *Datasheet*, no. V, p. 45, 2019, [Online]. Available: <https://www.ti.com/lit/ds/symlink/bq25570.pdf>.
- [38] "BQ25570EVM-206 Evaluation board | TI.com." <https://www.ti.com/tool/BQ25570EVM-206> (accessed May 20, 2022).